



INSTALLATION INSTRUCTIONS

Accessory
FRONT LOWER TRIM
P/N 08P46-STX-200B

Application
2010 MDX

Publications No.
BII 42087
Issue Date
JAN 2010

PARTS LIST

Front lower trim

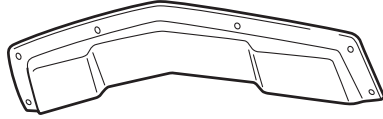

Front lower molding



4 Special bolts, 6 x 24 mm



2 Special bolts, 6 x 40 mm



6 Washers



2 Washer-nuts



4 Rivet nuts



4 Self-tapping screws



TOOLS AND SUPPLIES REQUIRED

Phillips screwdriver

Flat-tip screwdriver

19 mm Ratchet wrench

5 mm Hex bit

Torque wrench

10 mm and 19 mm Wrenches

Drill

3 mm, 7 mm and 9 mm Drill bits

File

Gloves

Eye protection (face shield, safety goggles, etc.)

6 mm Rivet Nut Tool (T/N 07AAE-STX-A100)

Masking tape

Duct tape

Tape measure

Service Manual

INSTALLATION

Client Information: The information in this installation instruction is intended for use only by skilled technicians who have the proper tools, equipment, and training to correctly and safely add equipment to your vehicle. These procedures should not be attempted by "do-it-yourselfers."

NOTE: Be careful not to damage the front bumper or other surfaces of the body.

1. Lift or jack up the vehicle as described in the Service Manual.

- Secure the front lower molding to the front bumper with the masking tapes in the position shown.

NOTE: Check the outside edge of the front lower molding to make sure there are no gaps.

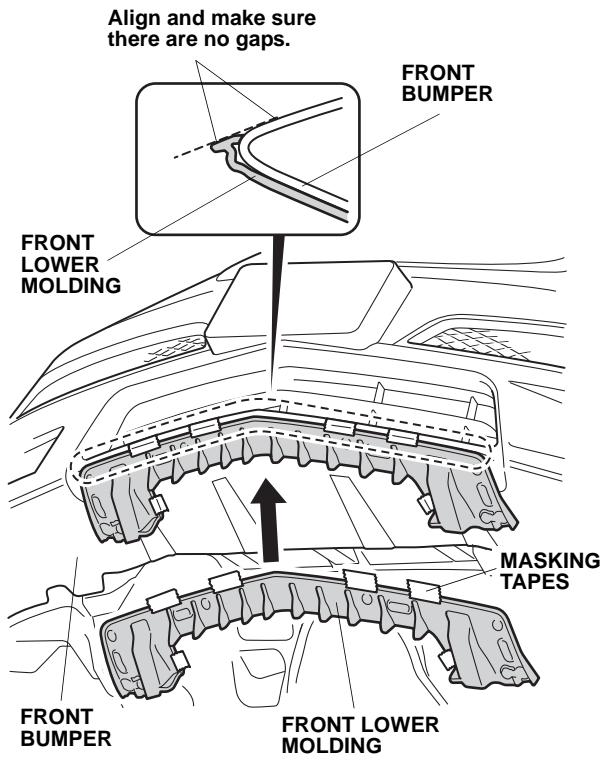

- Wrap the duct tape around a 3 mm drill bit 10 mm (0.4 in.) from the tip or use a drill stop.

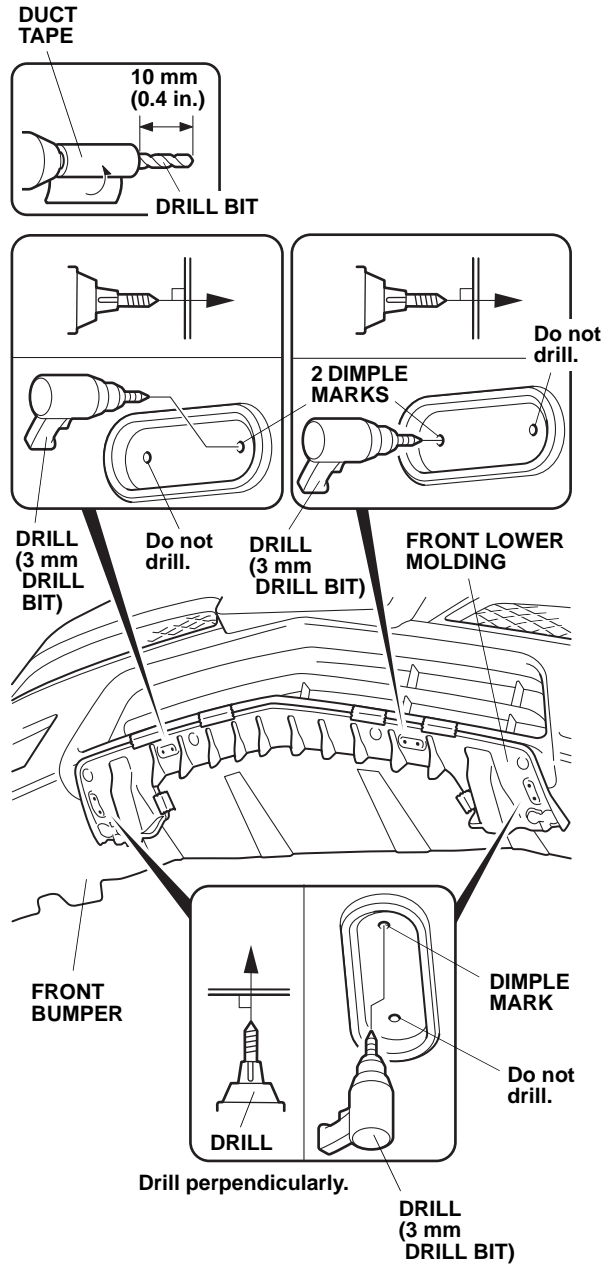

- While wearing eye protection and holding the front lower molding against the front bumper, drill a hole through the center of the four dimple marks. Drill with a 3 mm drill bit. Remove any burrs from the edges of the holes with a file.

- While holding the front lower molding against the front bumper, install four self-tapping screws. Remove the masking tapes attached in step 2.

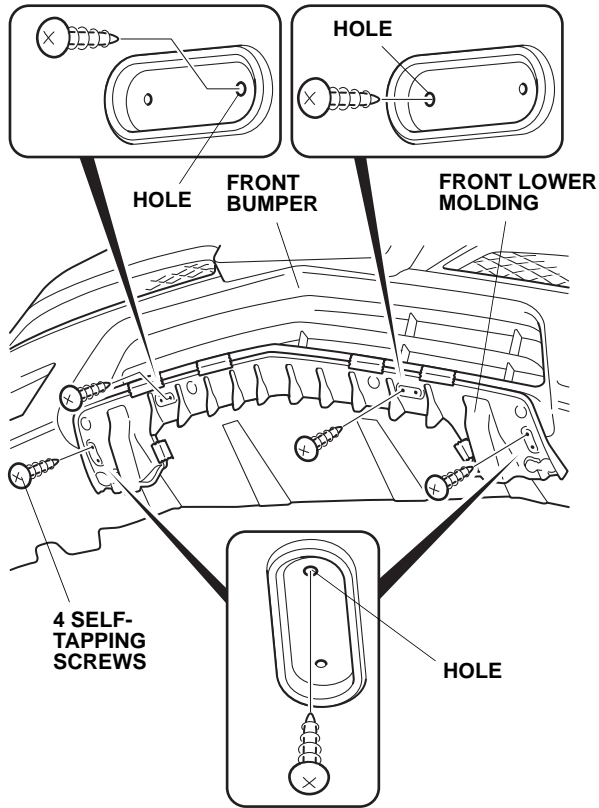

- Push and check the outside edge of the front lower molding to make sure there is no gapping.

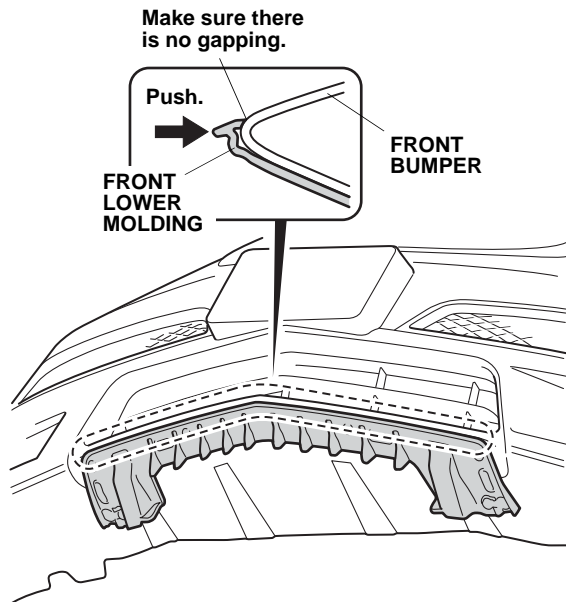

NOTE: If a gap is found to the outside edge of the front lower molding, remove the self-tapping screws, and realign the front lower molding. Repeat steps 3 and 4 to drill on the four alternate locations, and then reinstall the self-tapping screws to the alternate locations.

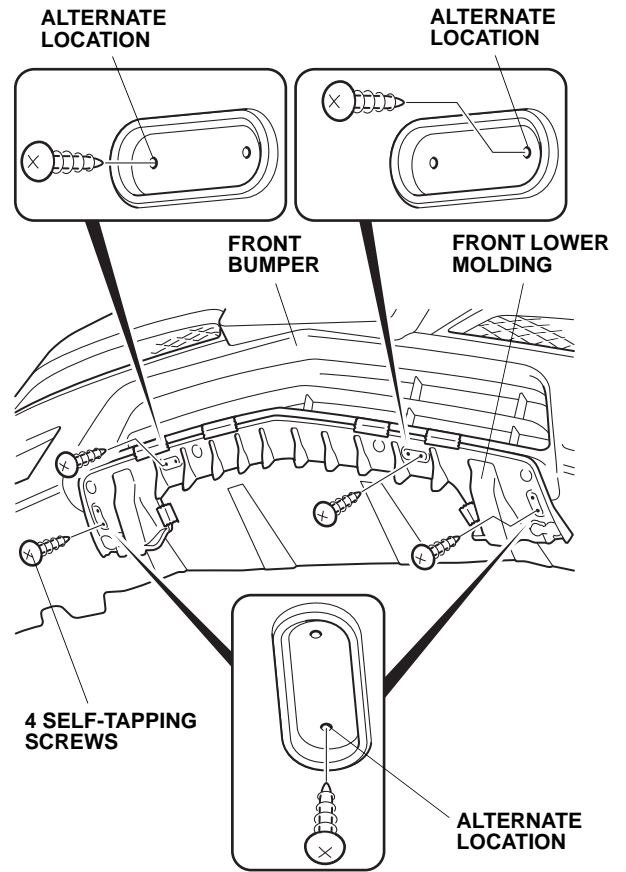

7. Wrap the duct tape around a 3 mm and a 7 mm drill bits 10 mm (0.4 in.) from the tip or use a drill stop.

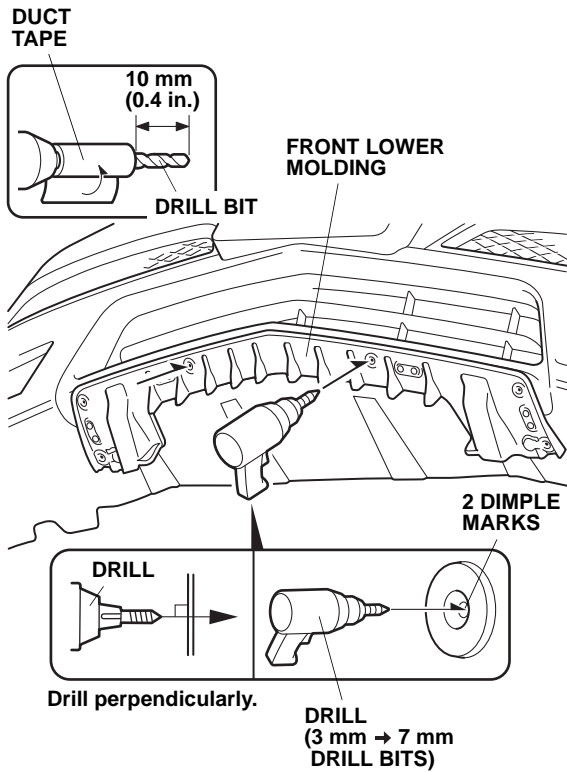

8. While wearing eye protection, drill a hole through the center of the two dimple marks. First drill with a 3 mm drill bit, and finish with a 7 mm drill bit. Remove any burrs from the edges of the holes with a file.

9. Wrap the duct tape around a 3 mm and a 9 mm drill bits 10 mm (0.4 in.) from the tip or use a drill stop.

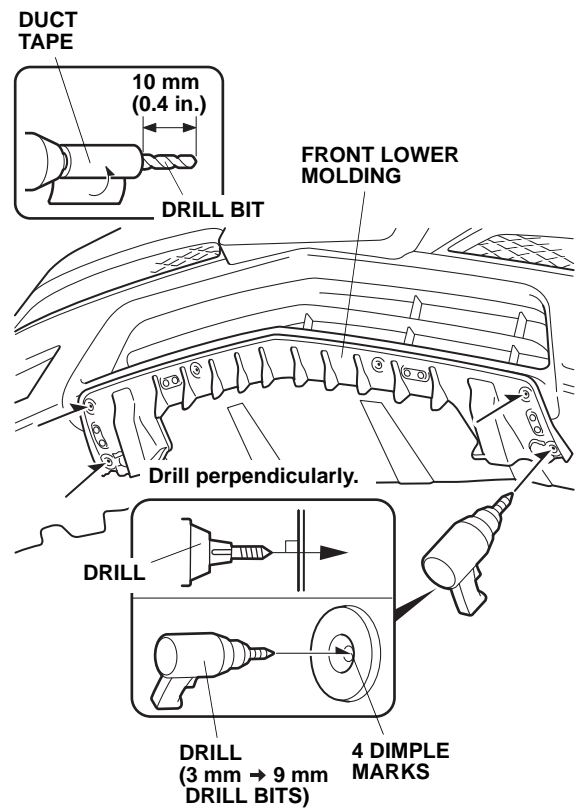

10. While wearing eye protection, drill a hole through the center of the four dimple marks. First drill with a 3 mm drill bit, and finish with a 9 mm drill bit. Remove any burrs from the edges of the holes with a file.

11. Install four rivet nuts in the holes in the positions shown by steps 12 through 17.

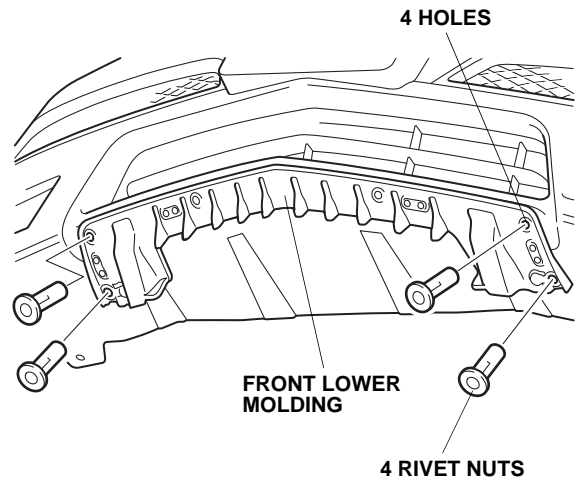

- Turn the nut in counterclockwise direction until the stud is fully extended.

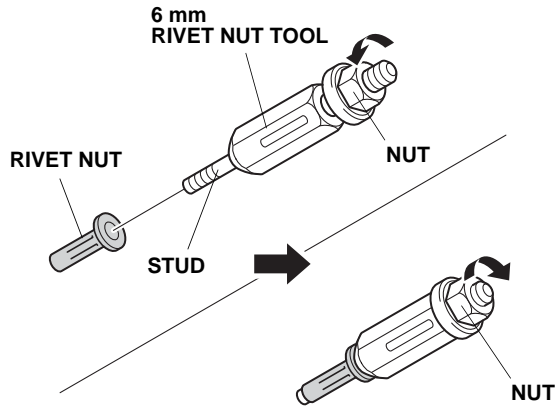

- Engage all threads on the stud into the rivet nut.
- Advance the nut until it becomes tight.
- Insert the rivet nut into the hole. Place the 19 mm wrench on the 6 mm rivet nut tool body, and hold stationary using a 19 mm ratchet wrench on the nut.

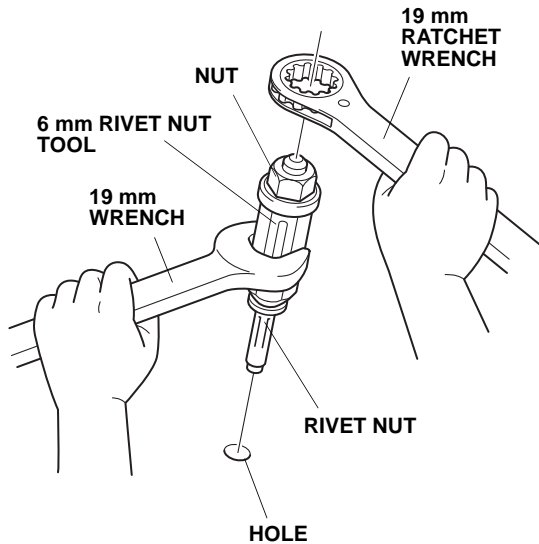

- Turn the 19 mm ratchet wrench clockwise while holding the 6 mm rivet nut tool perpendicular to the work. Turn the nut until firm resistance is felt. Several turns will be required.

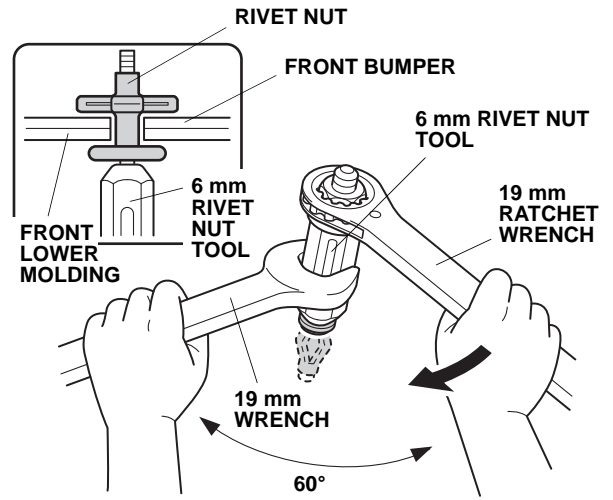

- Remove the 6 mm rivet nut tool from the rivet nut by turning 6 mm rivet nut tool body in a counterclockwise direction.

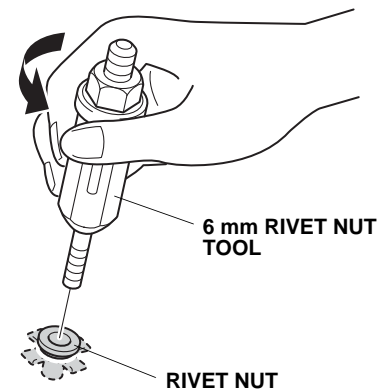

- Fold down the two hinge spacers of the front lower molding, and secure them with the duct tapes.

FRONT LOWER MOLDING

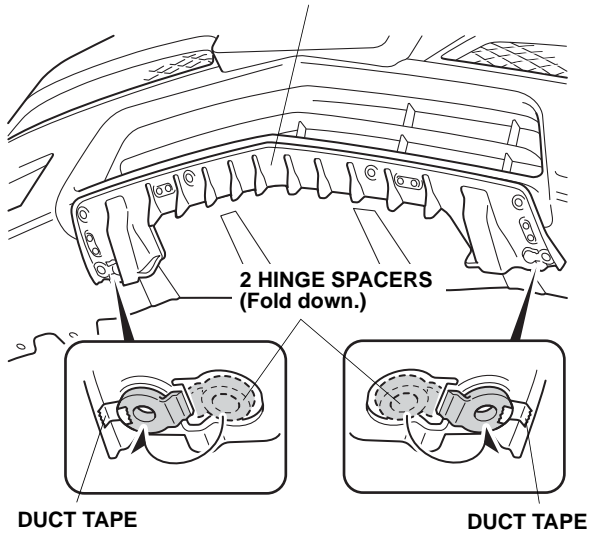

19. Position the front lower trim over the front lower molding, and install four washers, two 6 x 24 mm special bolts and two 6 x 40 mm special bolts. Do not tighten the special bolts yet.

FRONT LOWER MOLDING

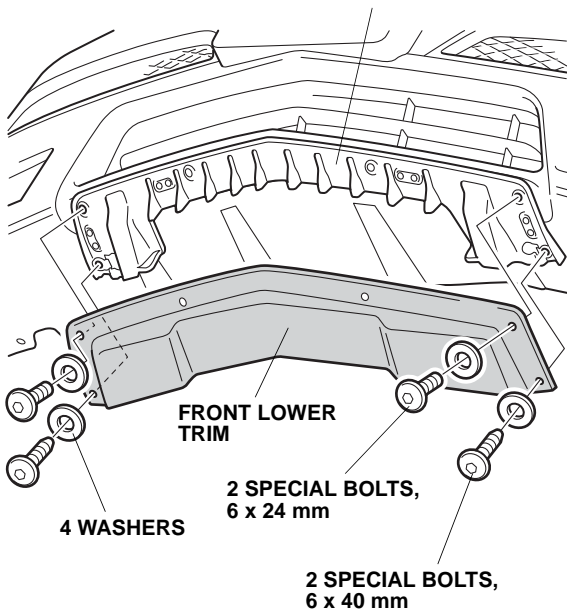

20. Remove the three clips from the hinges of the front bumper.

FRONT BUMPER

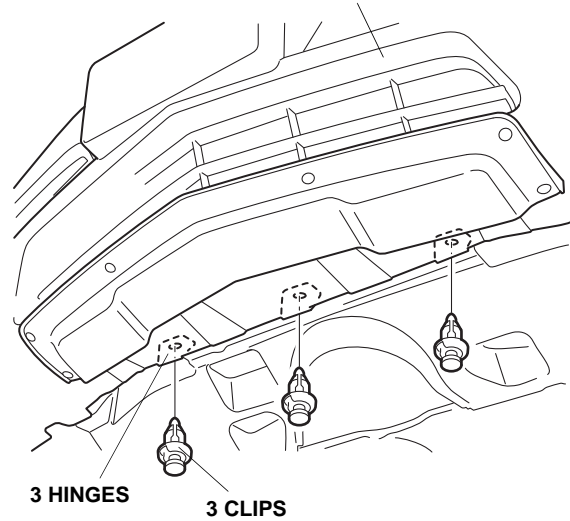

21. While wearing gloves, insert the washer-nuts to the inside of the front bumper from the clearance, and holding the washer-nuts. Install two washer-nuts, two washers and two 6 x 24 mm special bolts. Do not tighten the special bolts yet.

FRONT BUMPER

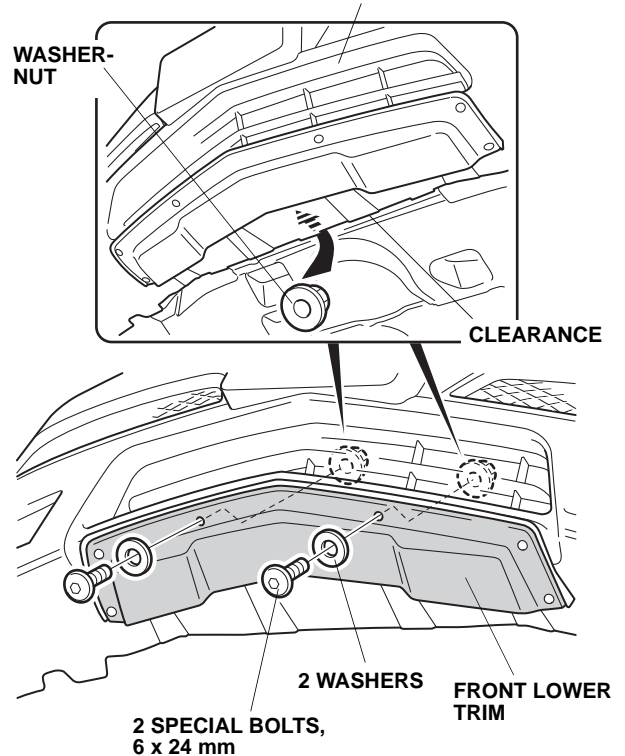

22. Tighten the special bolts in the order shown. Torque the special bolts to 6 to 9 N·m (4.4 to 6.5 lbf·ft).

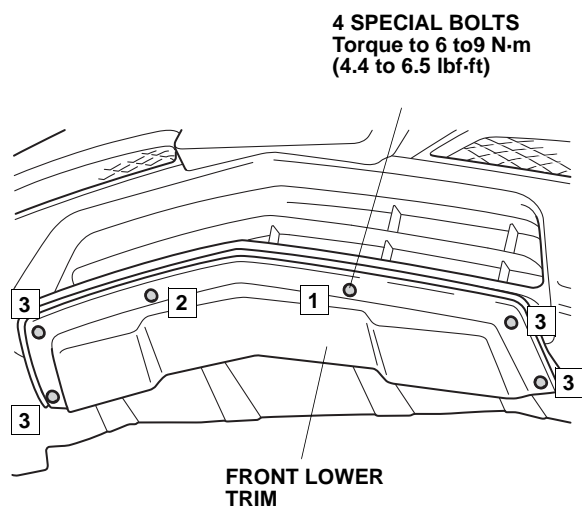

23. Confirm that hinges have been flipped over, and reinstall the clips removed in step 20.