



INSTALLATION INSTRUCTIONS

Accessory
FOG LIGHT
P/N 08V31-SDN-100

Application
ACCORD
2-DOOR

Publications No.
All 24075
Issue Date
AUG 2002

NOTE: The outside temperature gauge can not be installed in a vehicle with fog lights.

PARTS LIST

Right fog light

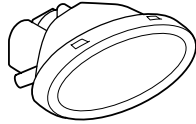

Left fog light

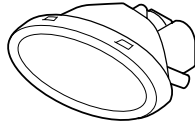

Right bracket A

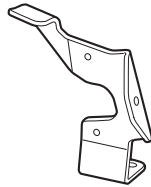

Left bracket A

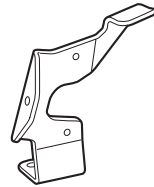

Right bracket B

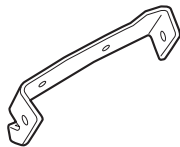

Left bracket B

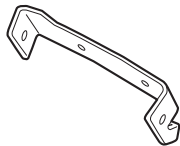

Right trim

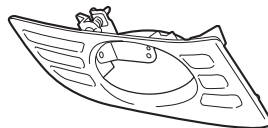

Left trim

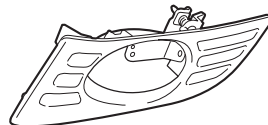

Fog light harness

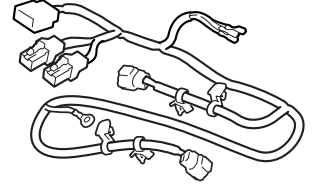

Switch harness

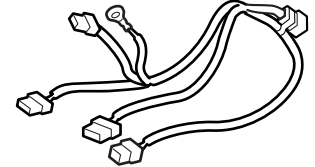

Switch

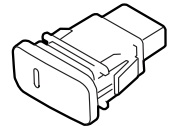

Relay (black)

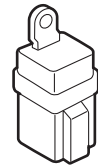

Relay (gray)

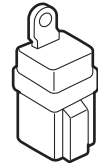

Fuse label

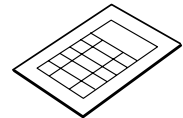

4 Self-tapping screws



4 Step-screws



2 Ground bolts



Washer, 6 mm



4 Washers, 5 mm
(gold)



4 Washers, 4 mm



3 Washer-bolts, 6 x 16 mm



4 Washer-bolts, 5 x 12 mm



4 Washer-screws, 4 x 12 mm
(black with big washer)



4 Washer-screws, 4 x 10 mm
(black with small washer)



2 Washer-screws, 4 x 8 mm
(gold)



25 Wire ties

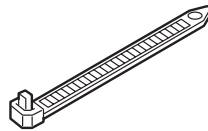

Relay bracket

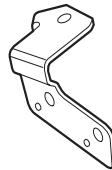

4 Spring nuts



Fuse (20A)



TOOL AND SUPPLIES REQUIRED

#2 Phillips screwdriver

Small flat-tip screwdriver

8 mm and 10 mm Combination wrench

10 mm Socket

Ratchet

File

Diagonal cutters

Masking tape

Utility knife

Illustration of the Fog Lights Installed on the Car

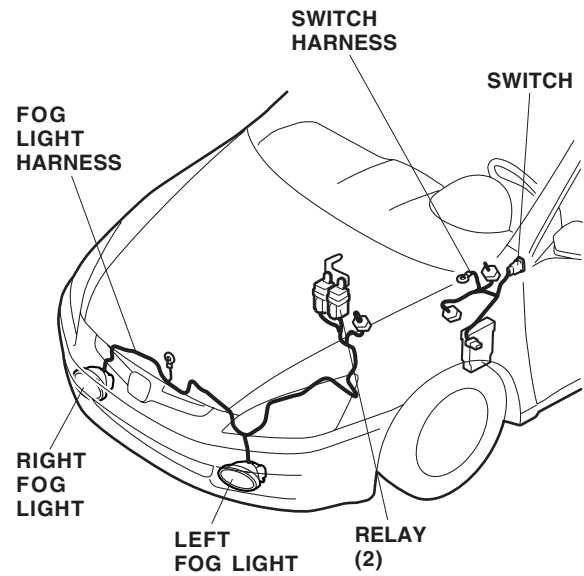

INSTALLATION

Customer Information: The information in this installation instruction is intended for use only by skilled technicians who have the proper tools, equipment, and training to correctly and safely add equipment to your car. These procedures should not be attempted by "do-it-yourselfers."

1. Make sure you have the anti-theft code for the radio, then write down the frequencies for the preset buttons.
2. Disconnect the negative cable from the battery.

Routing the Fog Light Harness

3. Open the hood. Remove the radiator cover (ten clips and four retaining tabs).

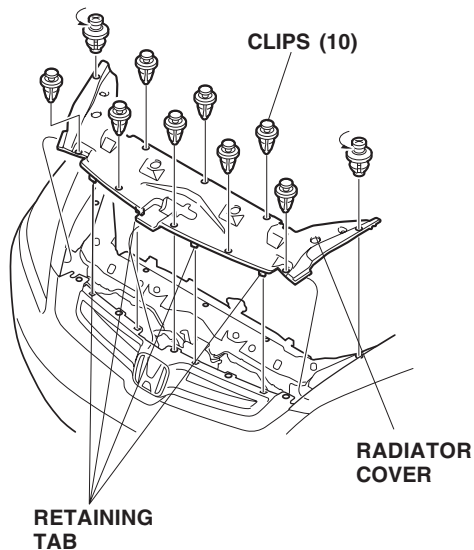

4. Remove the hood latch cover (one clip).

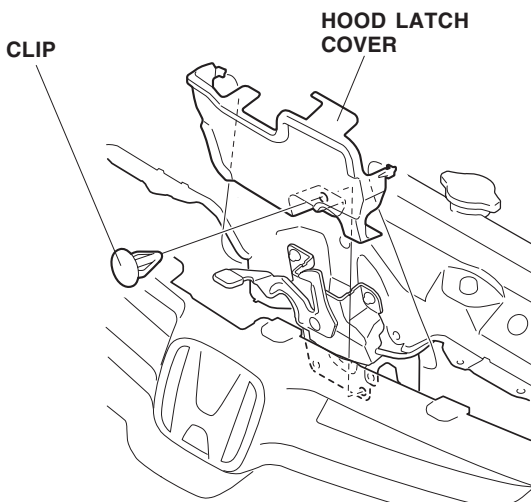

5. Remove the air duct cover (two clips and pull it out toward you). Remove the air duct by pulling it out toward you.

L4 Model:

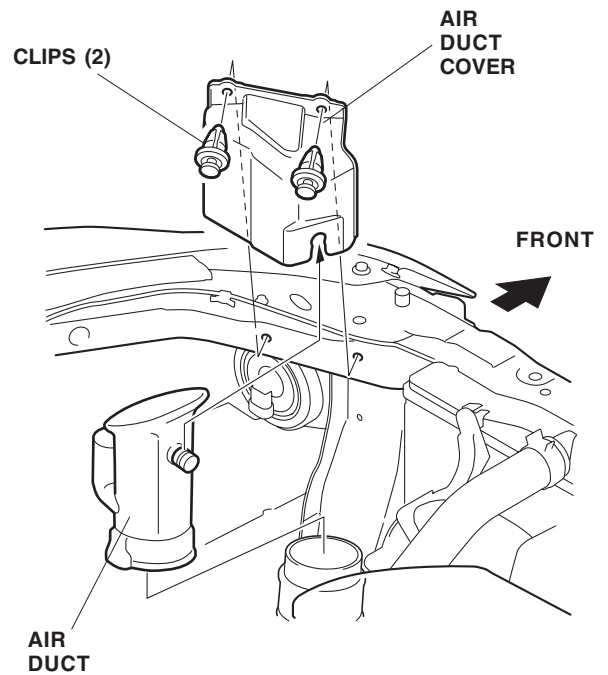

V6 Model:

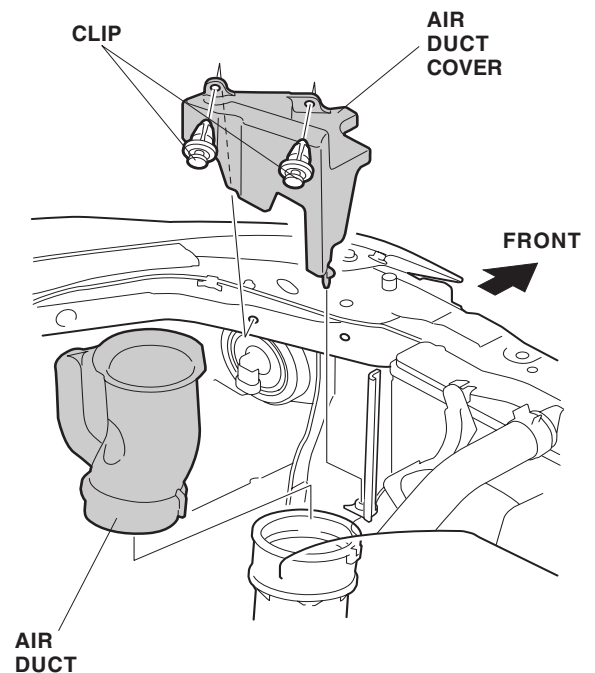

- Route the fog light harness 2-pin connector through the front bulkhead and alongside the vehicle harness.

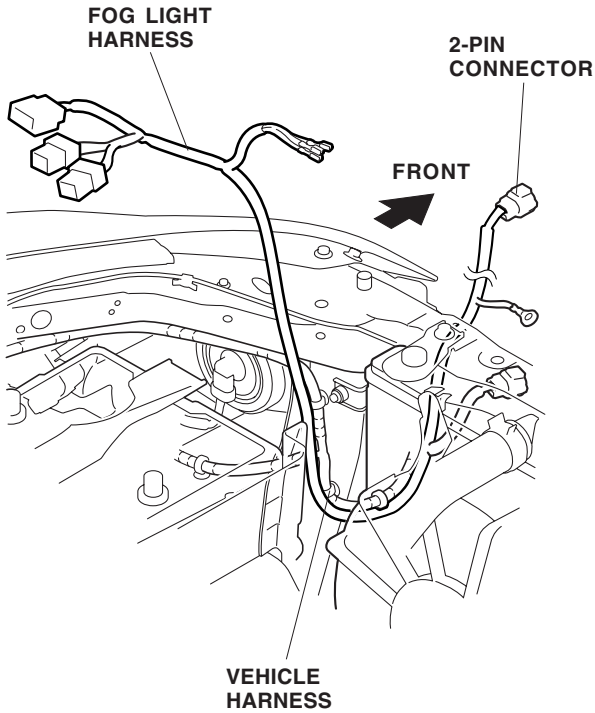

- Route the 2-pin connector end of the fog light harness to the front bulkhead alongside the vehicle harness.

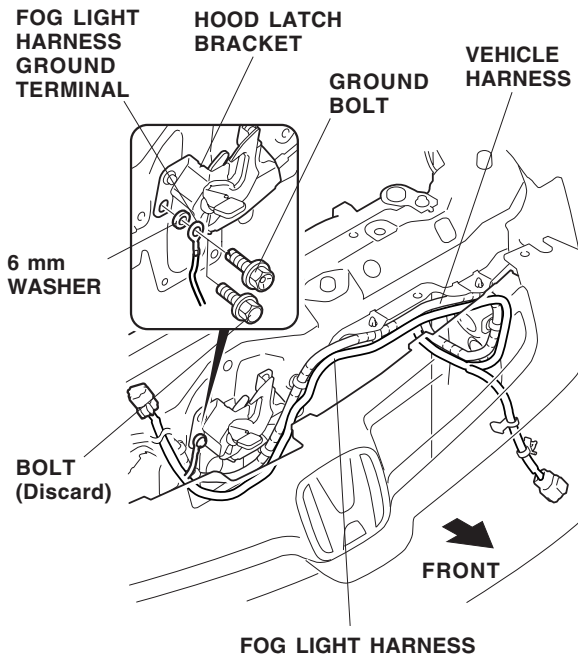

- Remove and discard the lower bolt that secure the hood latch bracket. Using one ground bolt and the 6 mm washer supplied, attach the fog light harness ground terminal to the hood latch bracket.

- On the left side of the vehicle, secure the fog light harness to the vehicle harness with the five wire ties in the areas shown. Push the fog light harness clip into the hole in the body panel.

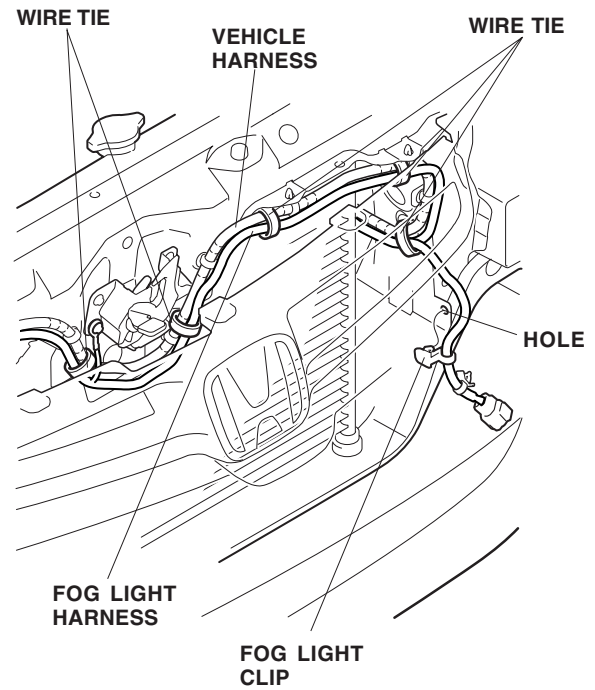

- On the right side of the vehicle, secure the fog light harness to the vehicle harness with four wire ties.

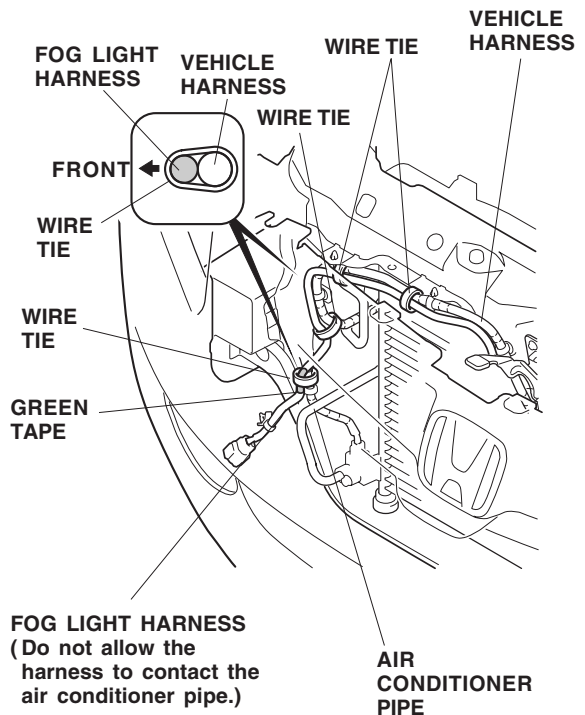

11. Remove the two bolts that fasten the relay box.

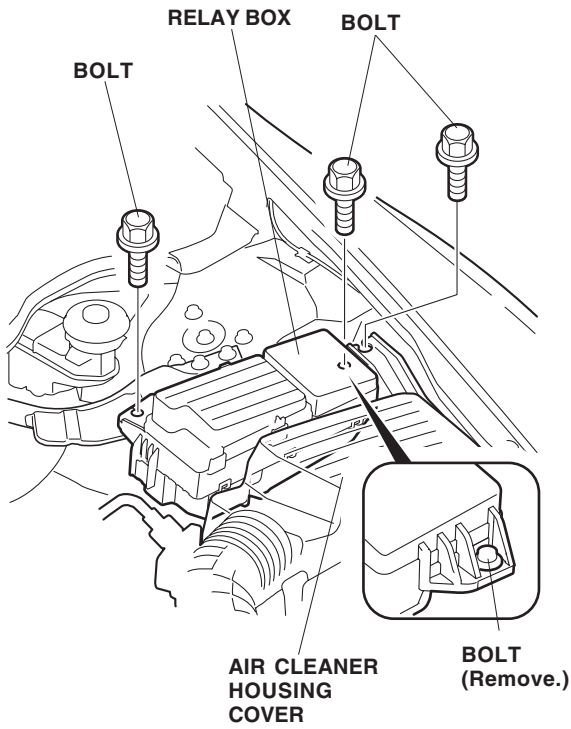

12. Remove the one bolt that fastens the air cleaner housing cover.

13. Release the six retaining tabs and remove the relay box under cover.

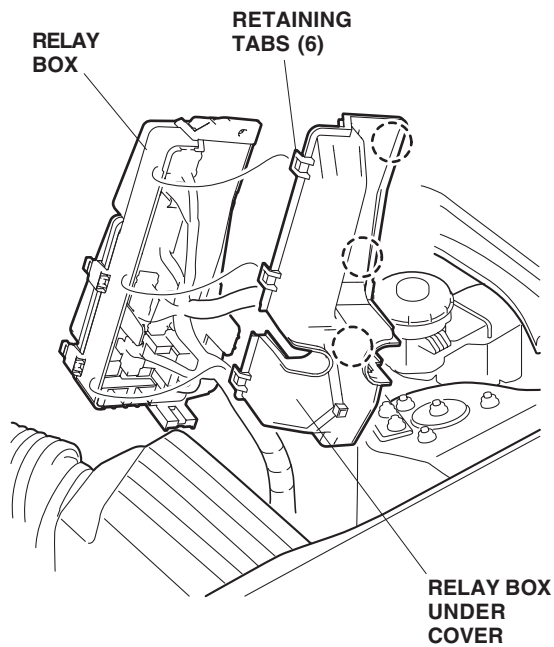

14. Lift the air cleaner housing cover up, and route the other end of the fog light harness toward the engine alongside the vehicle harness.

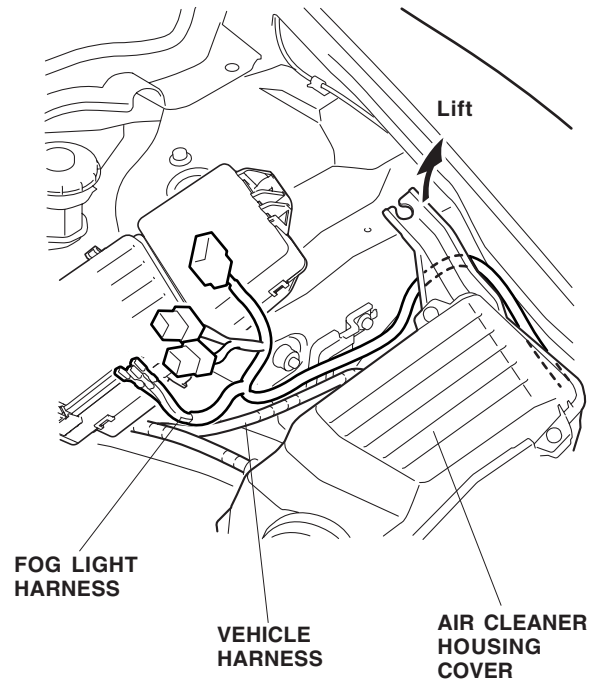

- Unplug the vehicle 14-pin and 20-pin connectors from the relay box. Release the lock on the vehicle 14-pin connector, and push the fog light harness white/green and red/green wire terminals into the vehicle 14-pin connector. Reattach the lock on the 14-pin connector.

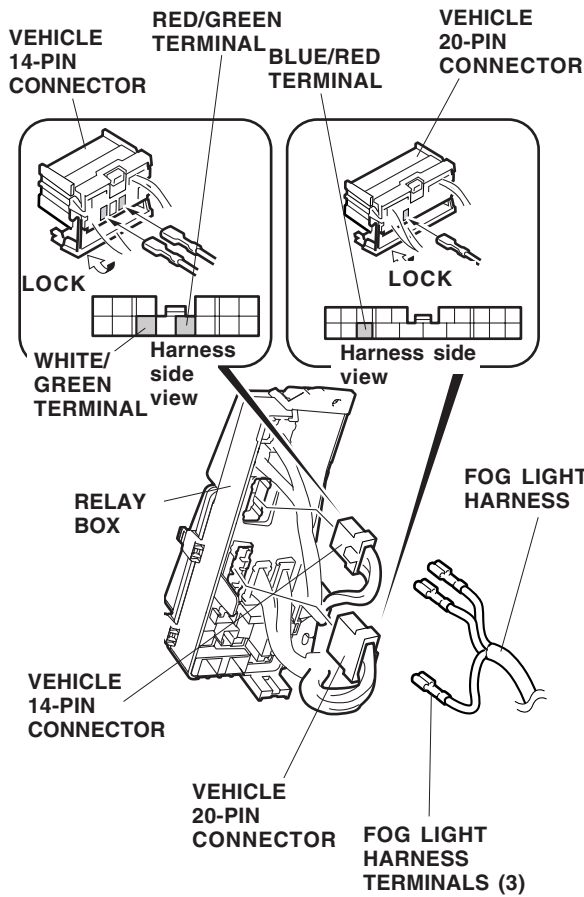
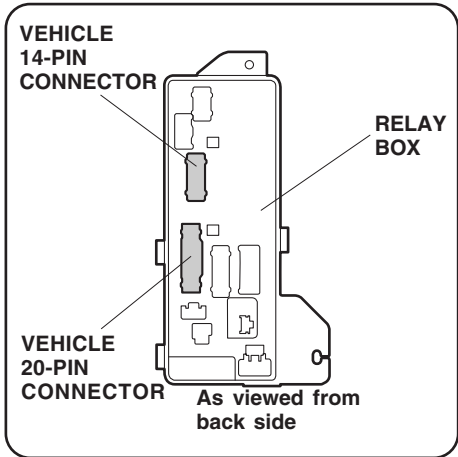

- Release the lock on the vehicle 20-pin connector, and push the fog light harness blue/red wire terminal into the vehicle 20-pin connector. Reattach the lock on the 20-pin connector.
- Plug the vehicle 14-pin and 20-pin connectors back into the relay box.

- Secure the fog light harness to the vehicle harness with one wire tie in the area shown.

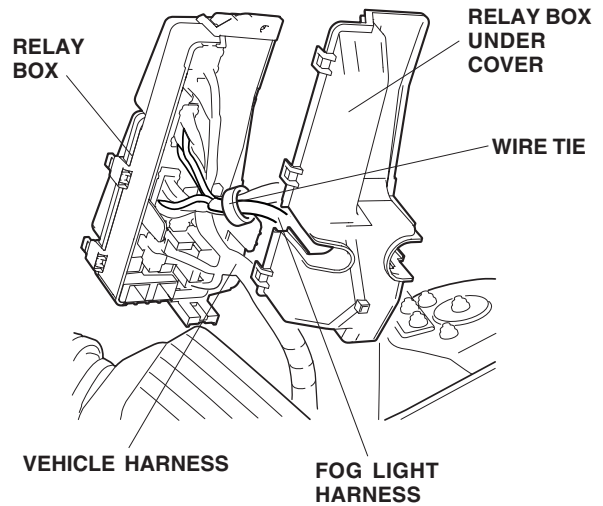

- Reinstall the relay box under cover. Be careful not to pinch the wires.
- Under the relay box, locate the vehicle 3-pin connector blue-taped to the vehicle harness, and remove the blue tape to free the connector. Connect the fog light harness 3-pin connector into the 3-pin connector you just freed. Secure the fog light harness to the vehicle harness with one wire tie in the area shown.

A/T Model:

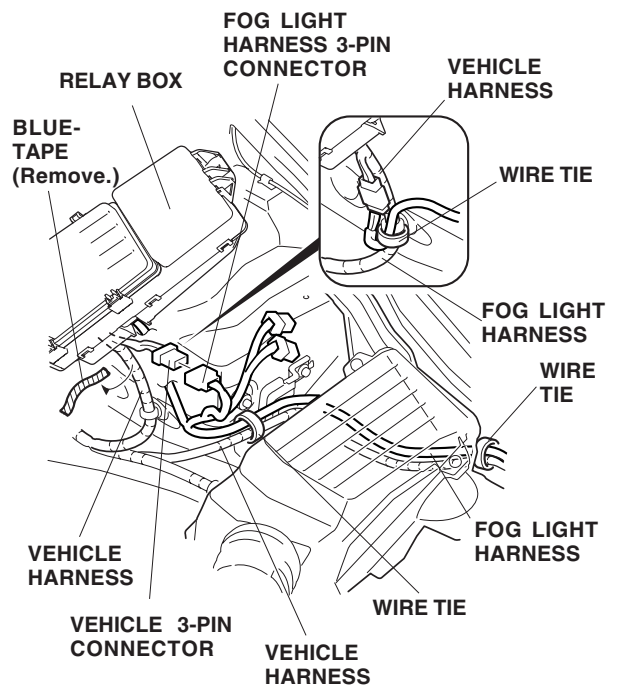

M/T Model:

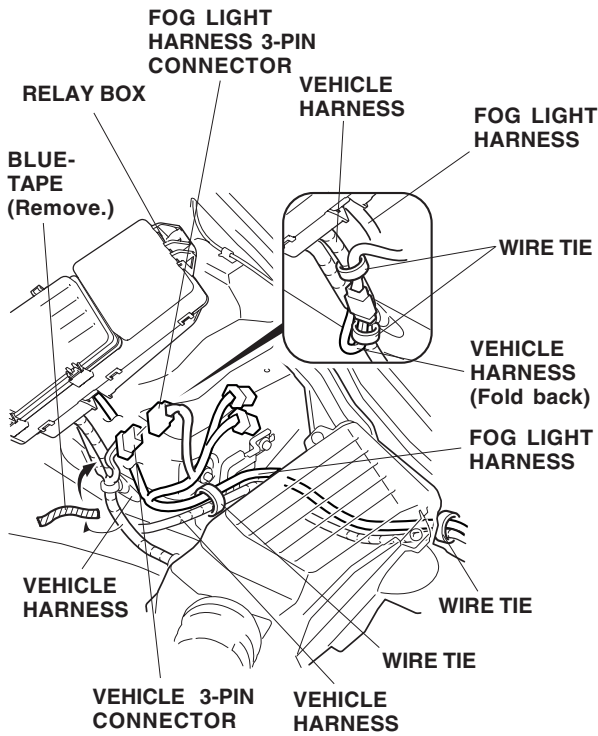

NOTE: If the 3-pin connector is already being used by another accessory, locate the 3-pin connector taped to that other accessory's harness. Remove the tape and dummy connector from that other accessory's harness. Plug the fog light harness 3-pin connector into that other accessory's harness.

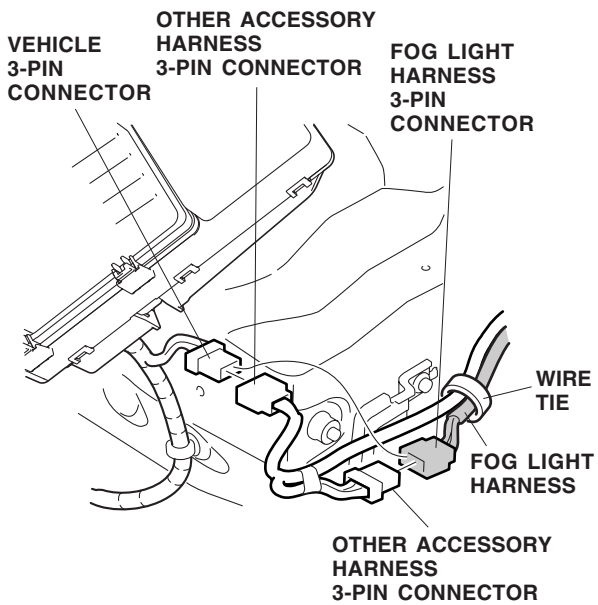

21. Install the relays (black and gray) to the relay bracket with two 6 x 12 mm washer-bolts.

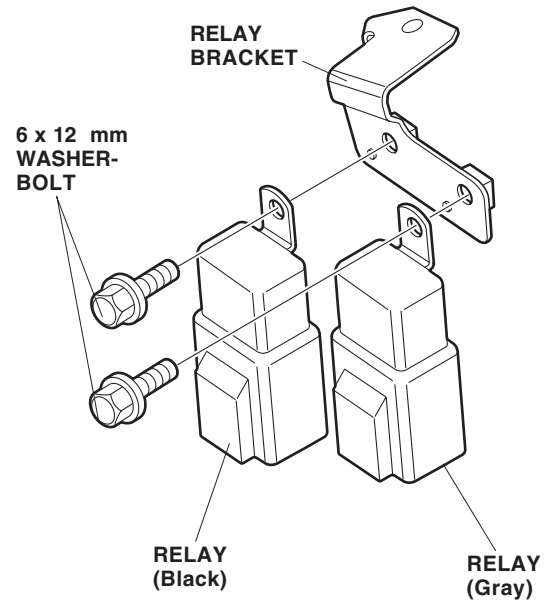

22. Plug the fog light harness two 4-pin connectors into the relays.

L4 Model:

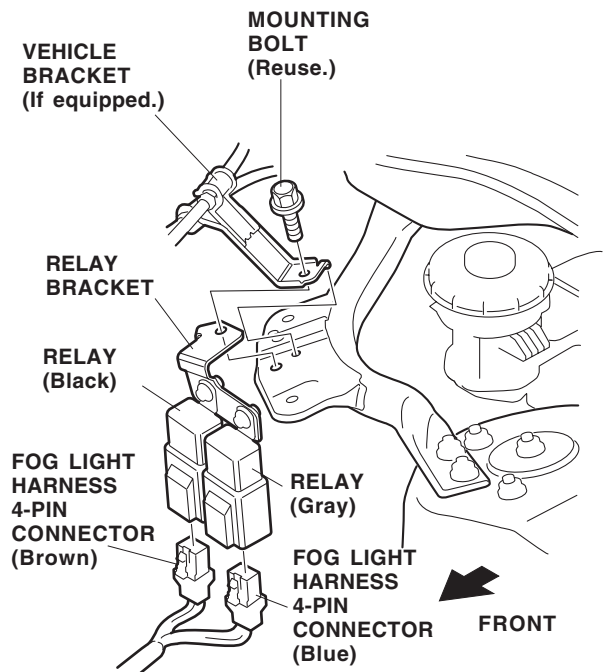

23. If equipped, remove the mounting bolt that secures the vehicle bracket, and attach the relay bracket with this bolt.

- On the V6 model, attach the relay bracket to the vehicle frame with the 6 x 12 mm washer-bolt supplied.

V6 Model:

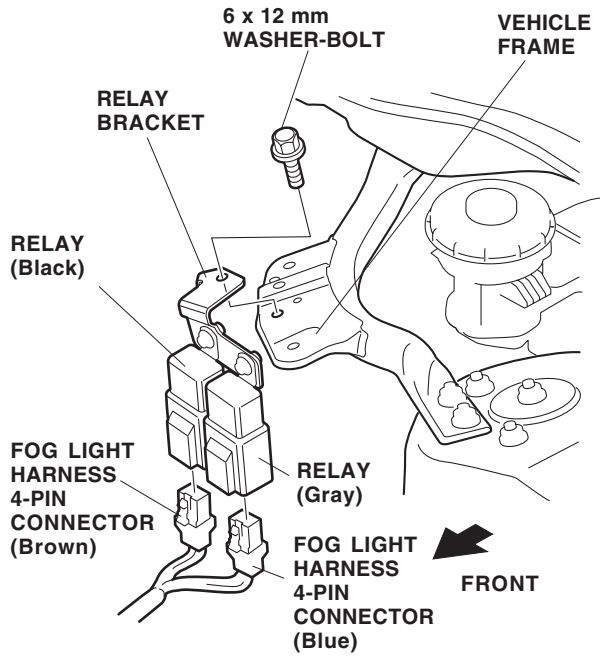

24. If the fog light harness is routed near a vehicle 4-pin harness connector, secure the fog light harness to the vehicle harness with one wire tie.

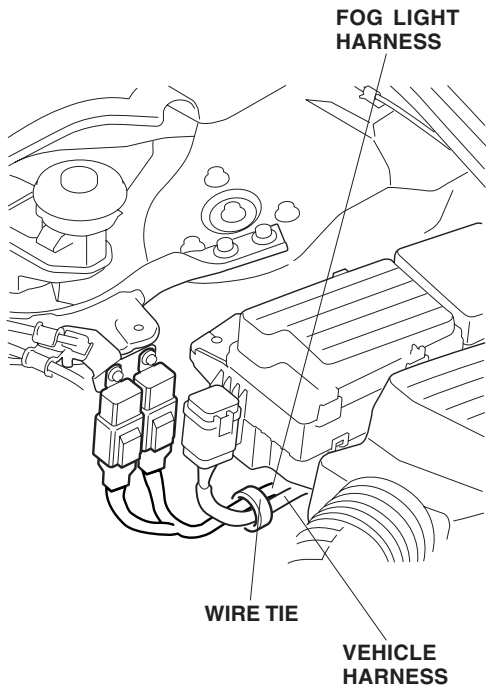

25. Secure the fog light harness to the vehicle harness with three wire ties in the areas shown.

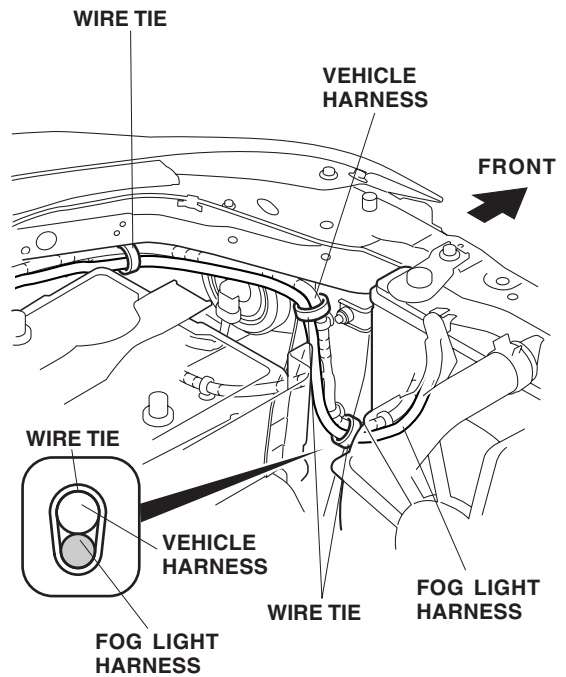

26. Remove the relay box cover (four retaining tabs), and install the 20A fuse (provided) into the No. 10 slot of the relay box.

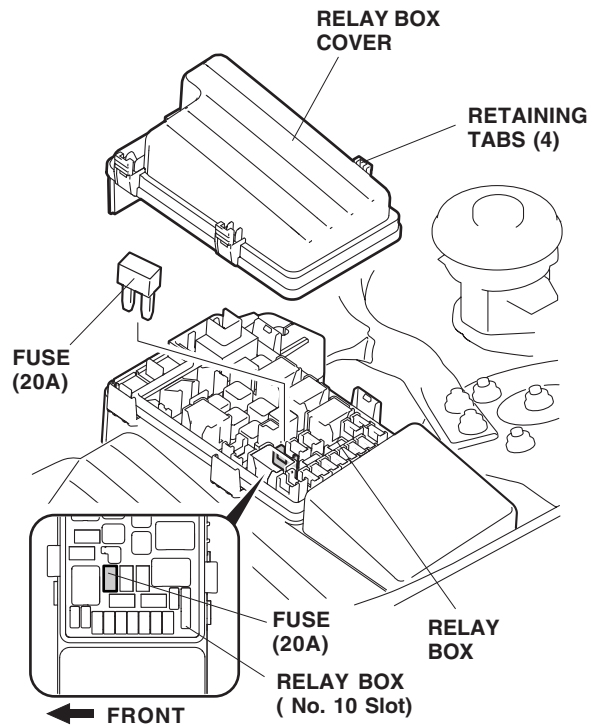

27. Attach the 20A fuse label over the No.10 slot of the relay box cover. Reinstall the relay box cover.

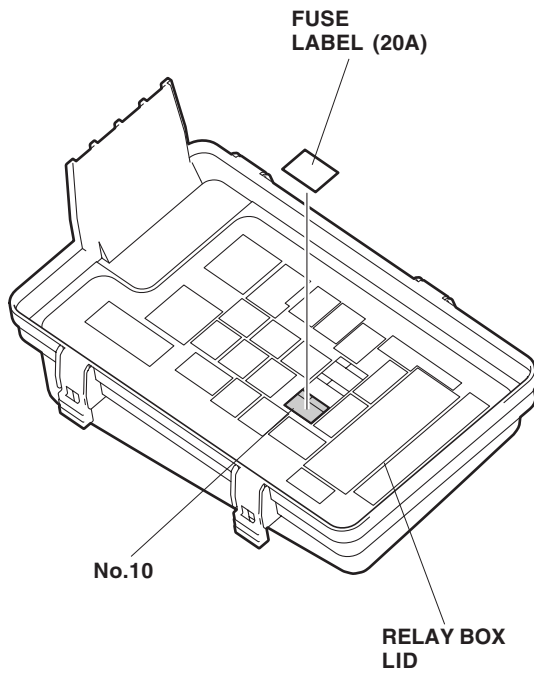

Installing the Fog Lights

If the vehicle you're working on is a V6 M/T model, continue with step 28, if not go to step 32.

28. Remove the front bumper (four bolts, six clips and two self-tapping screws).

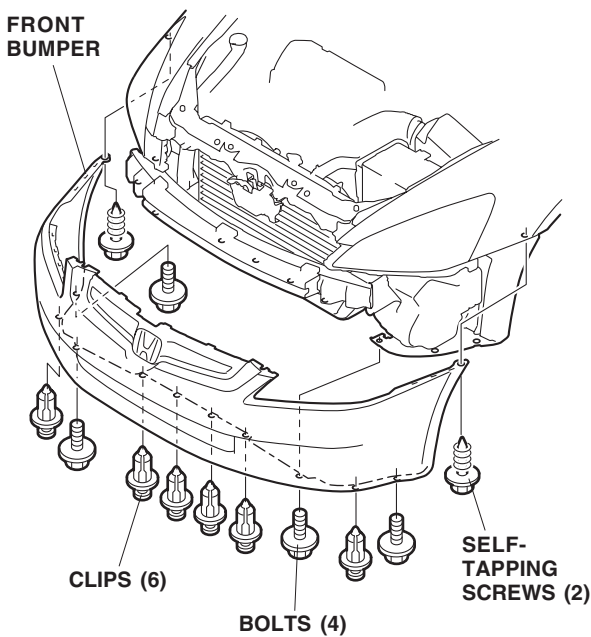

29. Remove the two self-tapping screws and remove the bumper duct and duct bracket.

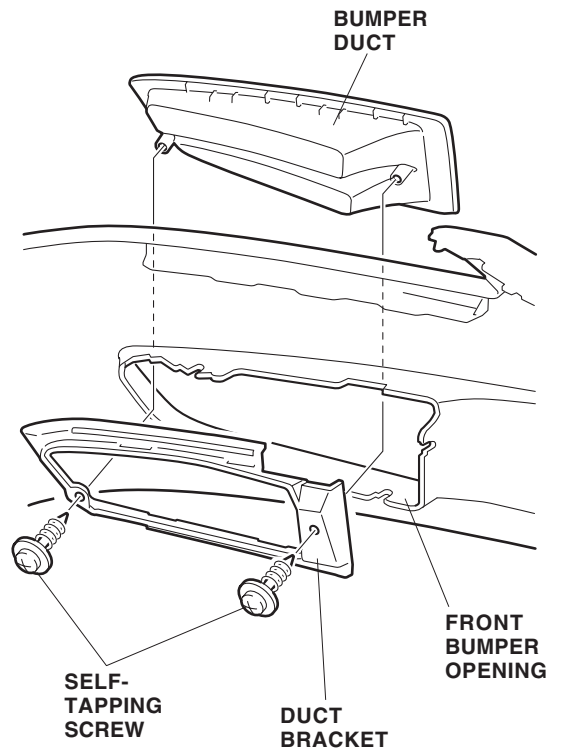

30. Attach the masking tape around the front bumper opening, and cut out the rib of the front bumper opening areas shown. Remove the burrs.

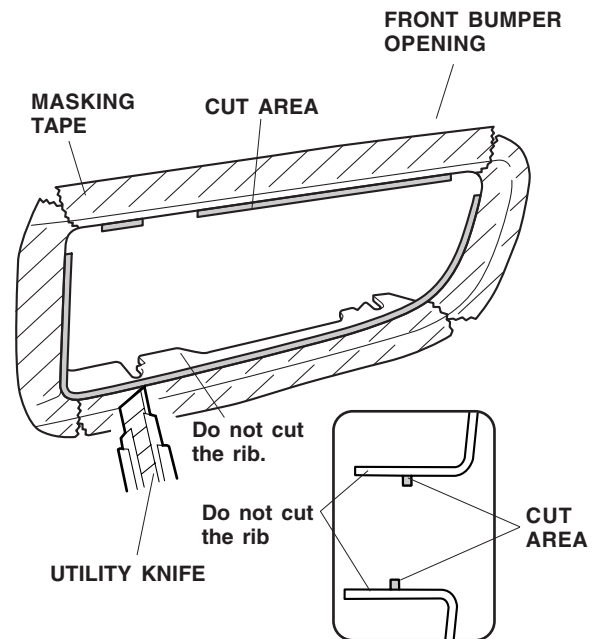

31. Repeat steps 29 and 30 on the other side of the bumper. Reinstall the front bumper, then go to step 35.

32. To prevent damage to the front bumper, apply masking tape to the front bumper on the left side of the vehicle in the area shown.

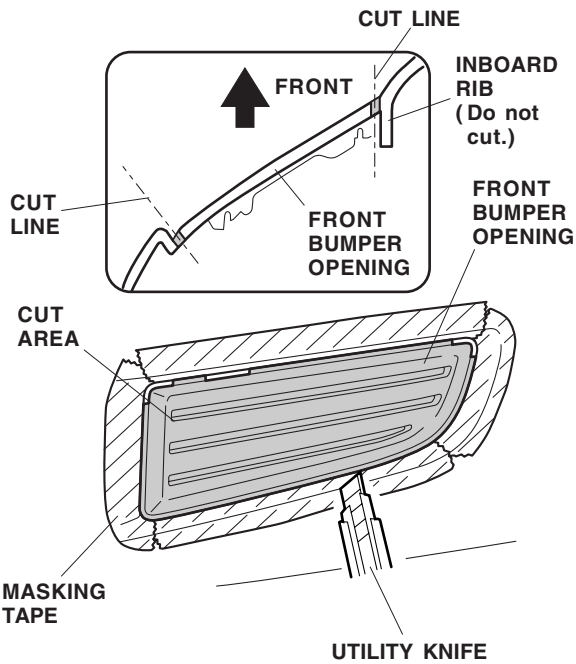

33. Being careful not to cut the inboard rib, use a utility knife to cut out the fog light opening.
34. Repeat steps 32 and 33 to cut out the right fog light opening.

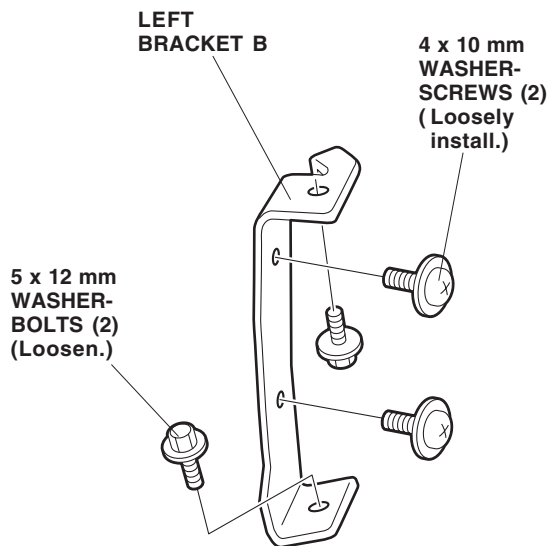

35. Loosely install the two 5 x 12 mm washer-bolts and 4 x 10 mm washer-screws to the left bracket B.

36. Slide the left bracket B onto the outside rib of the front bumper opening, then tighten the two 5 x 12 mm washer-bolts with the left bracket B pulled toward the front.

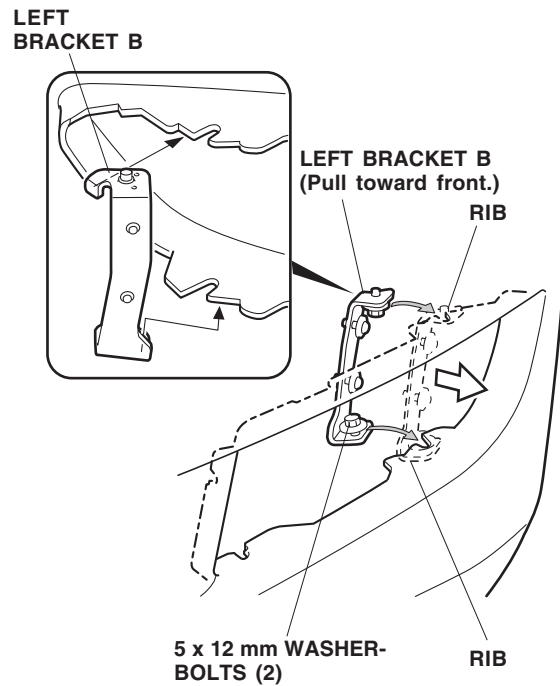

37. Attach two spring nuts onto the ribs of the front bumper opening.

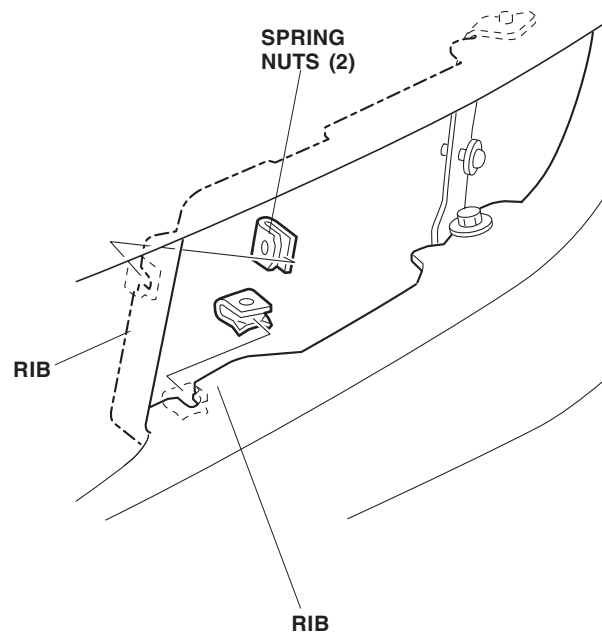

38. With the left bracket A pulled out toward the front, attach it to the front bumper opening with two self-tapping screws.

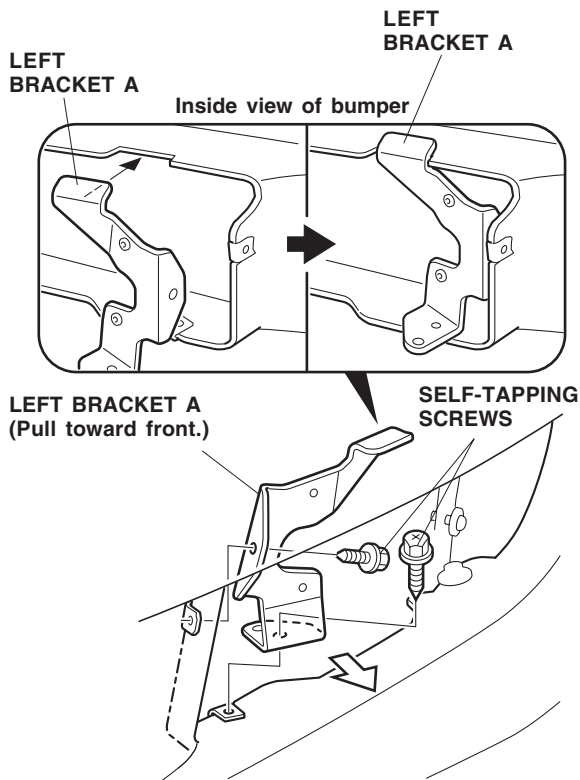

39. Install the left fog light into the left trim with two step-screws and one 4 x 8 mm washer-screw.

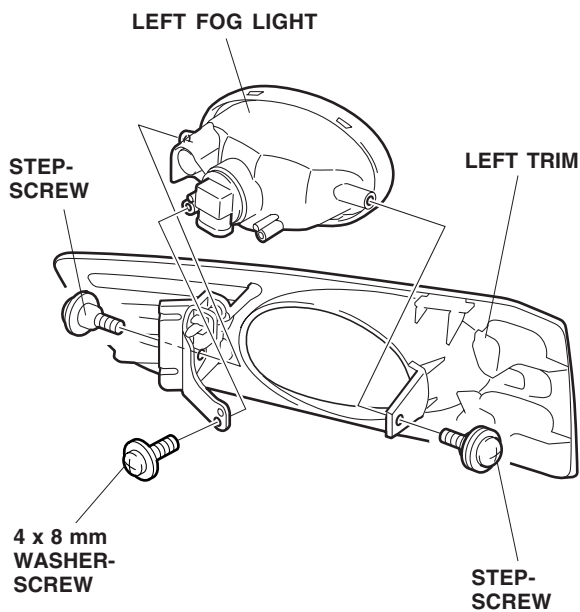

40. Install two 4 x 12 mm washer-screws and two 4 mm washers to the left trim.

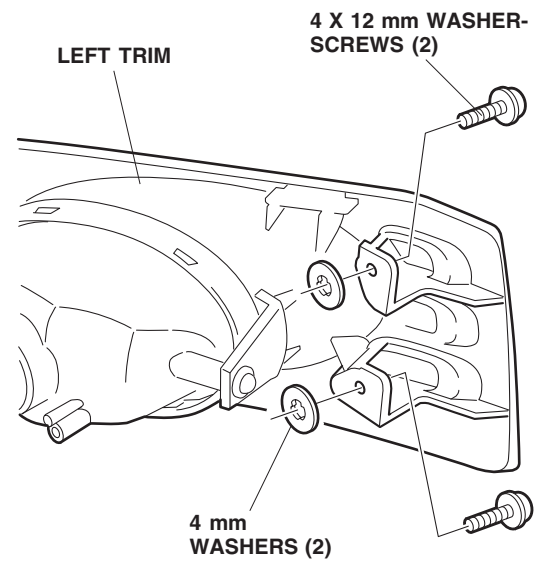

41. Install the fog light harness clip into the hole in left bracket A.

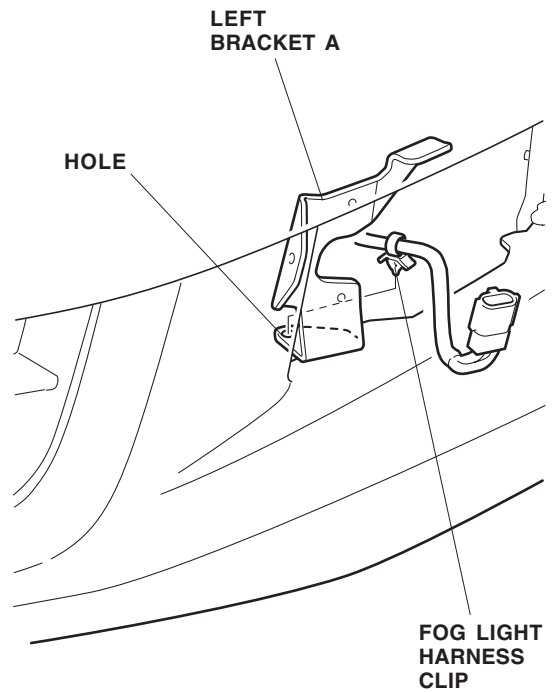

42. Connect the fog light harness 2-pin connector to the left fog light. Position the fog light on the front bumper, and tighten the two 4 x 12 mm washer-screws and two 4 x 10 mm washer-screws.

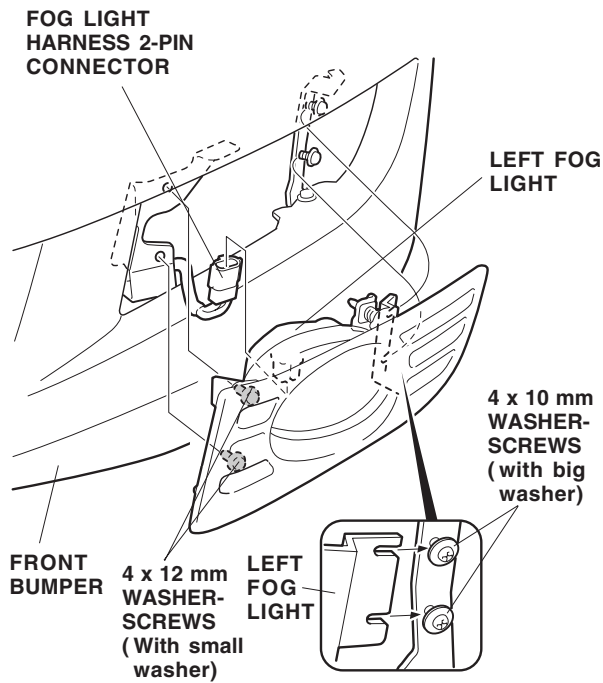

43. Repeat steps 35 thru 42 to install the right fog light.

Routing the Switch Harness

44. Remove the driver's dashboard lower cover:

- Remove the one self-tapping screw.
- Release the four clips on the left side first by pulling out on the driver's dashboard lower cover.
- After releasing the four clips, insert the flat-tip screwdriver between the clip and the dashboard frame. Gently twist the screwdriver to release the clip.
- Release the two clips on the right side last.
- Unplug the vehicle connector, and remove the lower cover.

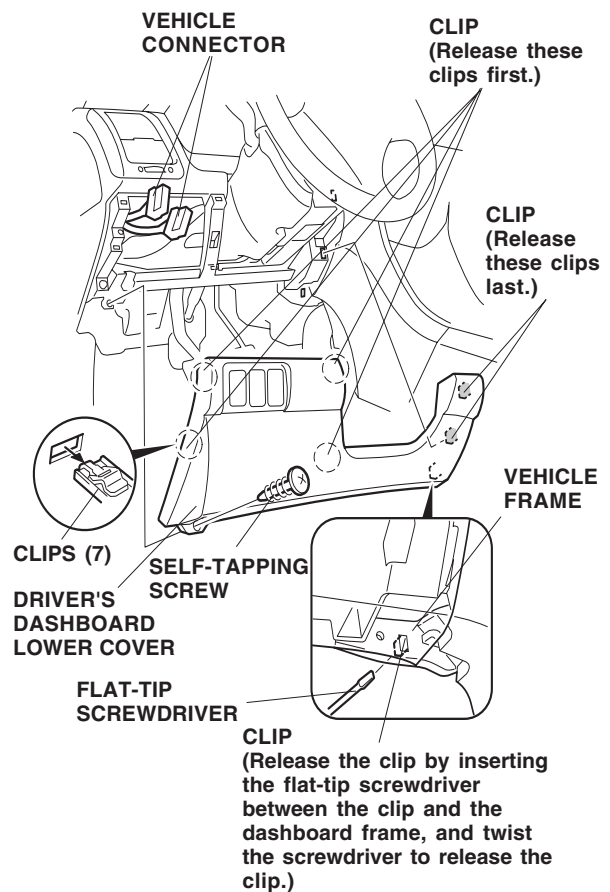

45. If equipped, remove the driver's dashboard under cover (three clips, one pin, and one holder).

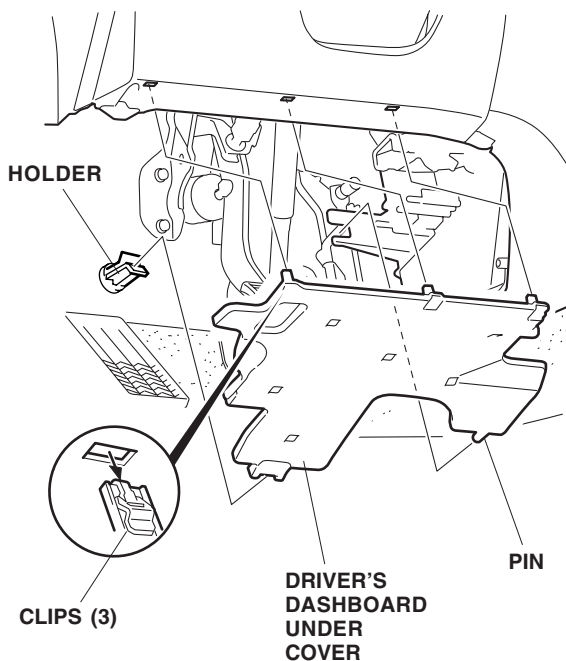

46. Plug the switch harness 6-pin connector into the 6-pin connector of the fuse box.

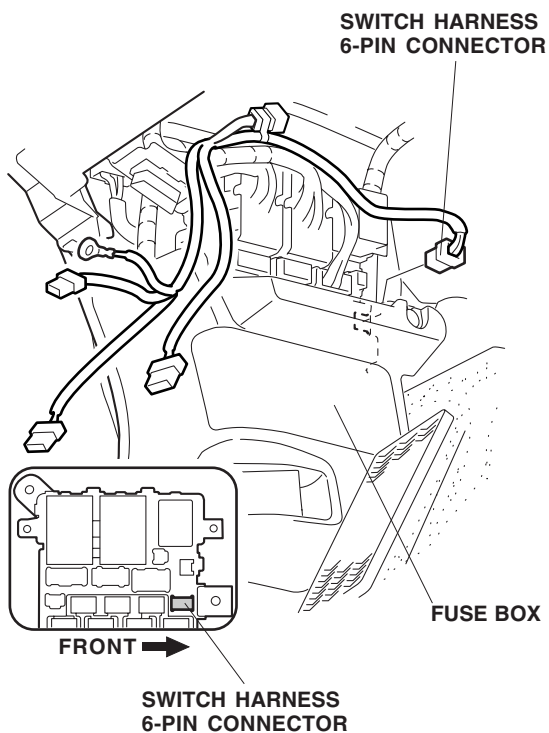

NOTE: If the fuse box 6-pin connector is already being used by another accessory, unplug its 6-pin connector from the fuse box. Locate the 6-pin connector taped to the switch harness. Remove the dummy connector from switch harness. Plug the other accessory's harness 6-pin connector into the switch harness, and plug the switch harness 6-pin connector into the fuse box.

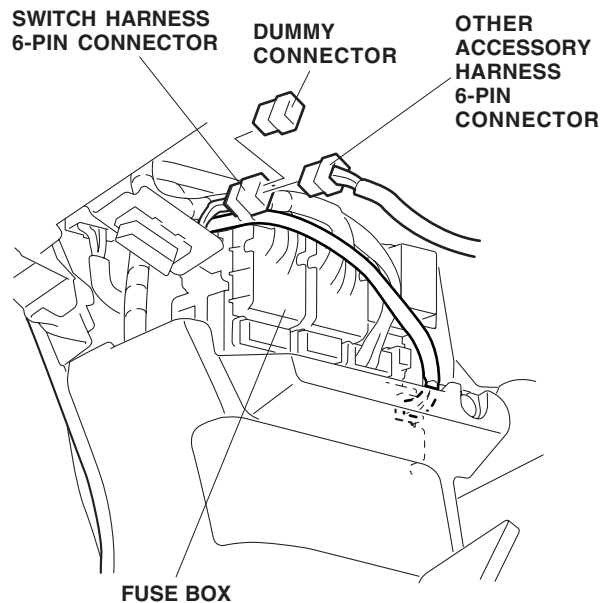

47. Route the switch harness 5-pin connector (blue) through the body panel opening alongside the vehicle harness. Secure the switch harness to the vehicle harness with one wire tie in the area shown.

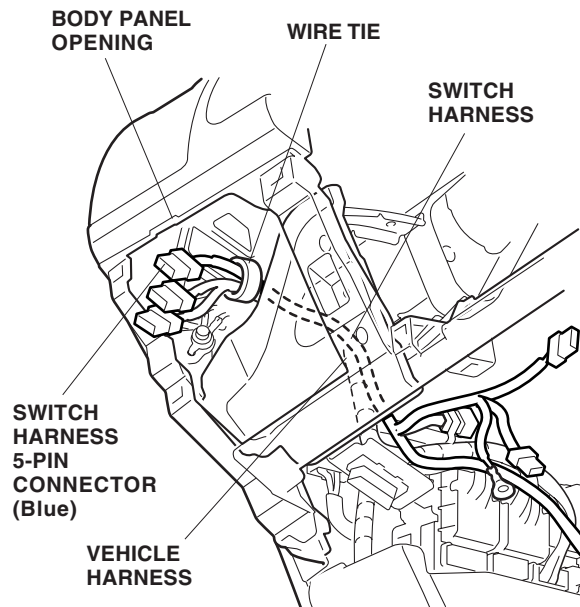

48. Behind the steering hanger pipe, locate the 2-pin connector blue-taped to the vehicle harness. Connect the switch harness 2-pin connector to the vehicle 2-pin connector.

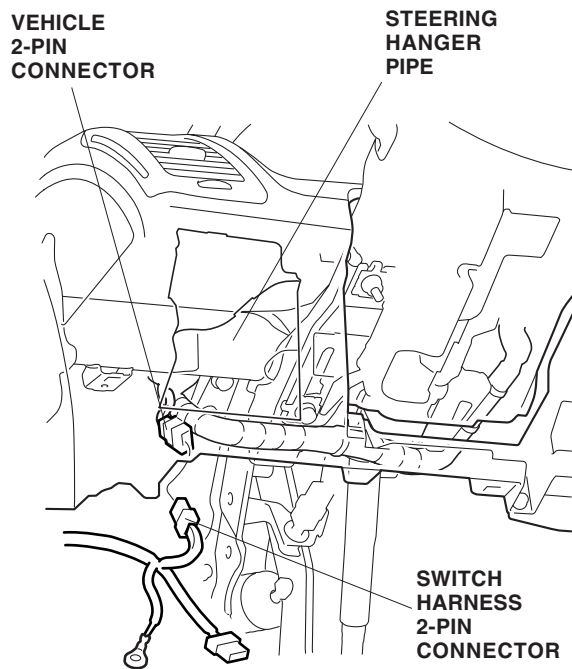

NOTE: If the 2-pin connector is already being used by another accessory, locate the 2-pin connector taped to that other accessory's harness. Plug the switch harness 2-pin connector into the other accessory's harness.

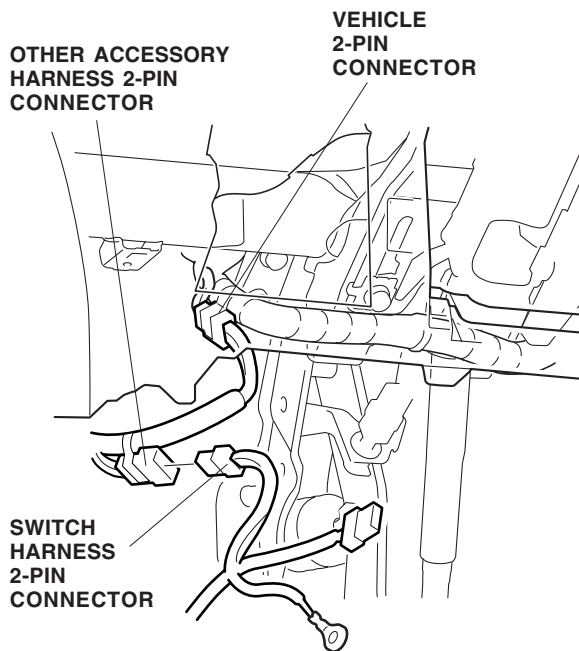

49. Attach the switch harness ground terminal to the steering hanger pipe stay with one of the ground bolt supplied.

Without a Cruise Control Unit:

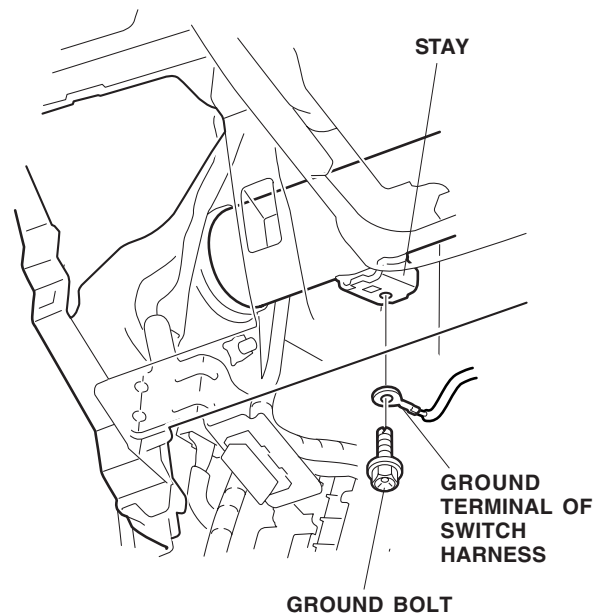

With a Cruise Control Unit:

- Remove and discard the bolt that fastens the control unit, then attach the switch harness ground terminal to the steering hanger pipe with one ground bolt supplied.

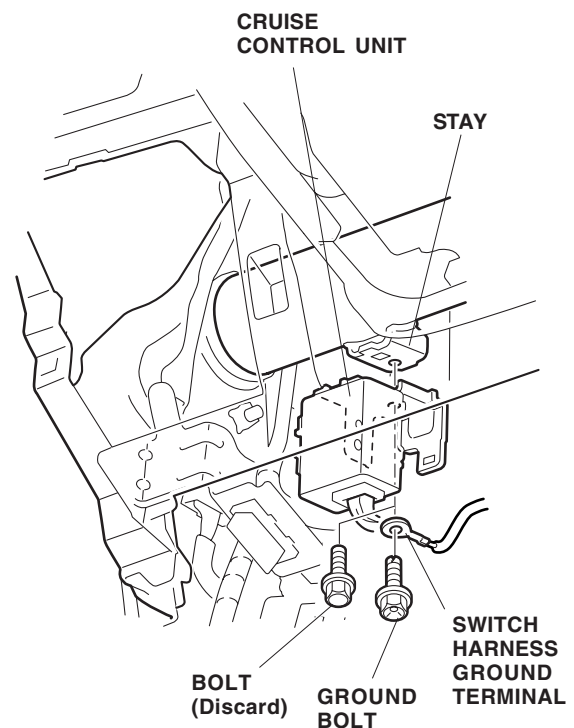

50. On the left of the steering shaft, locate the 3-pin connector black-taped to the vehicle harness, and plug the switch harness 3-pin connector into the vehicle 3-pin connector.

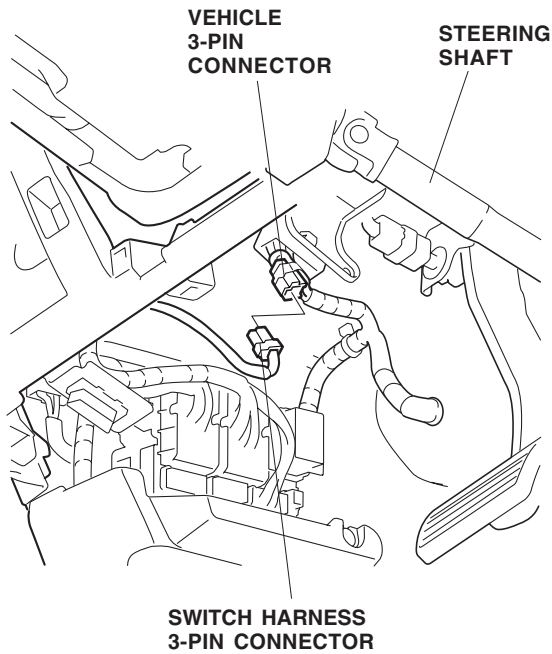

NOTE: If the 3-pin connector is already being used by another accessory, locate the 3-pin connector taped to that other accessory's harness. Remove the dummy connector from that other accessory's harness. Plug the switch harness 3-pin connector into the other accessory's harness.

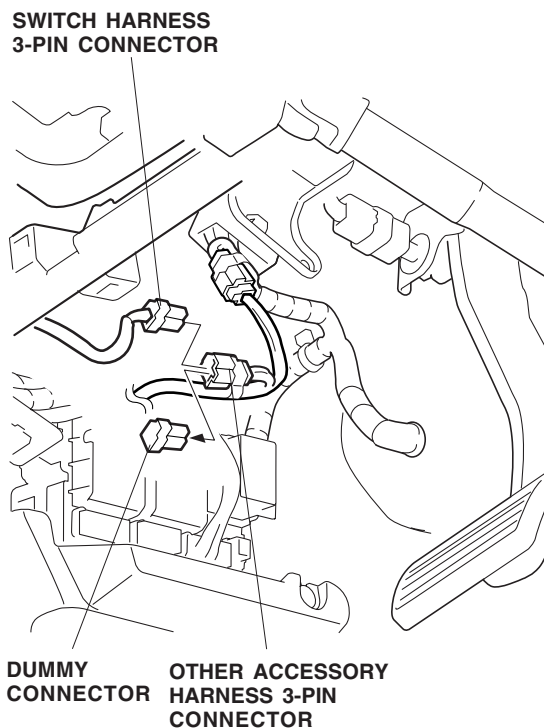

51. Secure the switch harness to the vehicle harness with six wire ties in the areas shown.

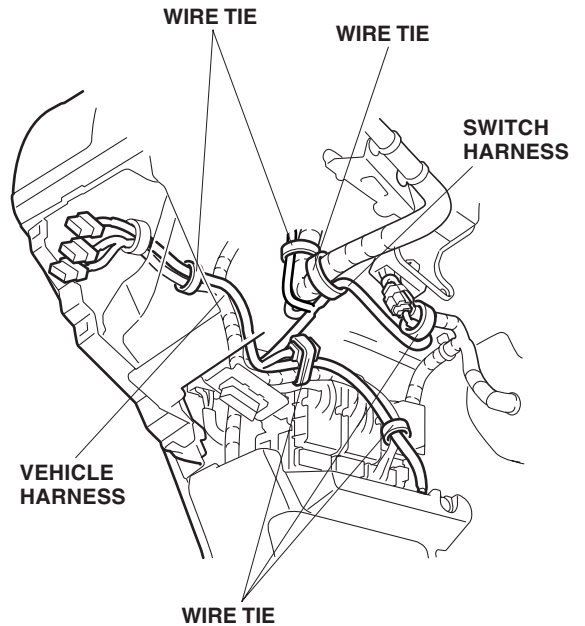

52. Remove the switch cover from the driver's side dashboard lower cover, and install the switch in the driver's dashboard lower cover.

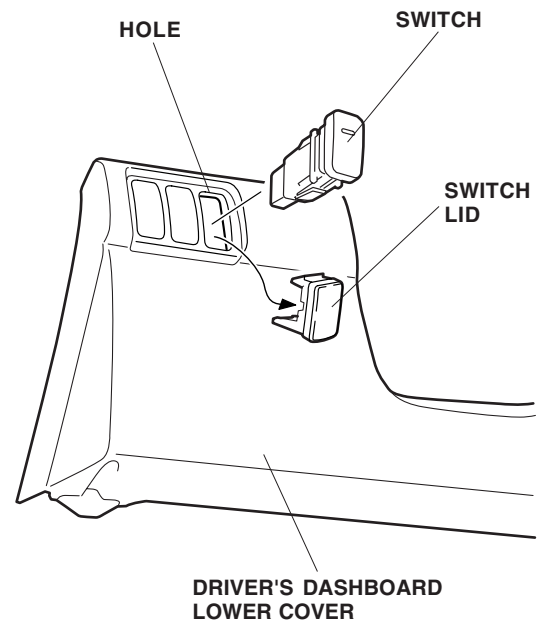

53. If equipped, reinstall the driver's dashboard under cover.

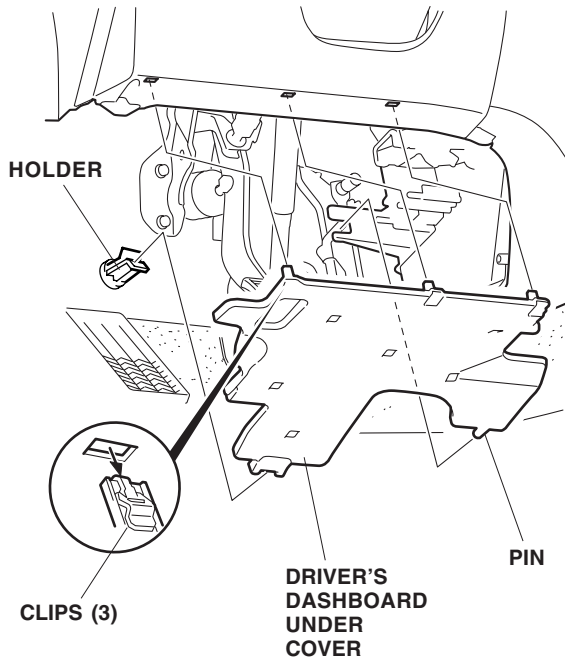

54. Plug the switch harness 5-pin connector (blue) into the switch, then reinstall the dashboard lower cover.

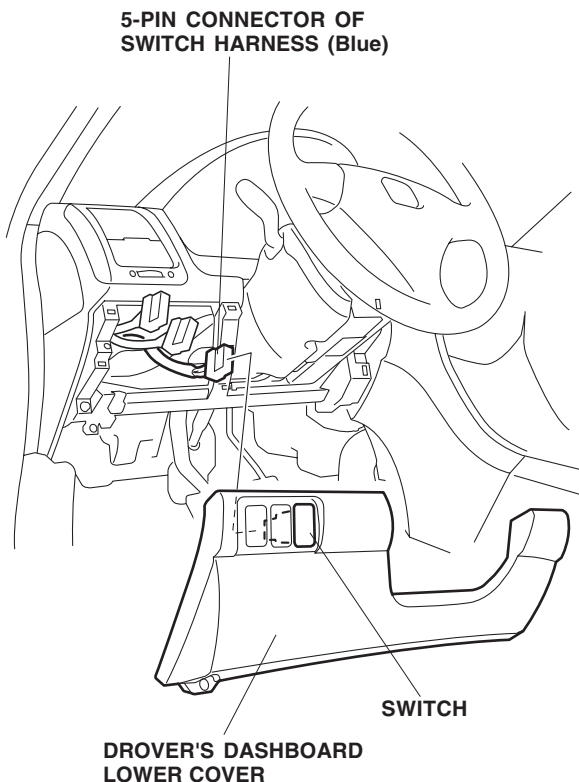

55. Check that all wire harnesses are routed properly and all connectors are plugged in.
56. Reinstall all removed parts. Check that all clips and fasteners are installed securely.
57. Reconnect the negative cable to the battery.

USE AND CARE

How to Operate Fog Lights

- Turn the headlight switch to the "on" position (headlights on low beam).
- Press the fog light switch (indicator is on).

The fog light lenses can cloud when the outside temperature is cold; this is normal and should go away in warm weather.

Fog Light Aiming Adjustment

58. Adjust the fog light:
- Adjust the aiming according to local laws and regulations.
 - To adjust, turn the aiming adjustment screw in or out until the correct aiming is obtained.

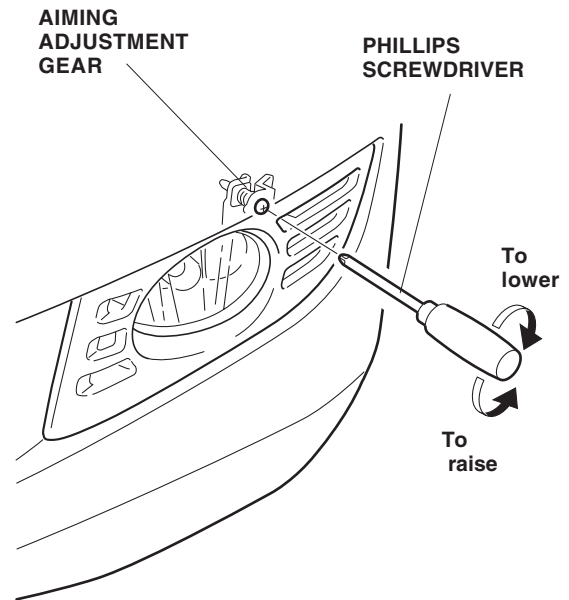

59. Reset the clock, and reset the radio station presets.

NOTE: Whenever the battery is disconnected, the driver's window AUTO function is disabled.

60. Start the engine. Push down on the driver's window switch until the window is fully open.
61. Pull up on the driver's window switch fully to close the window completely, then hold the switch for 2 seconds.
62. Test the driver's window AUTO function.

BULB REPLACEMENT

1. Remove the two 4 x 12 mm washer-screws, and loosen the two 4 x 10 mm washer-screws that fasten the fog light. Pull the fog light out toward you, unplug the connector from the fog light, and remove the fog light assembly.

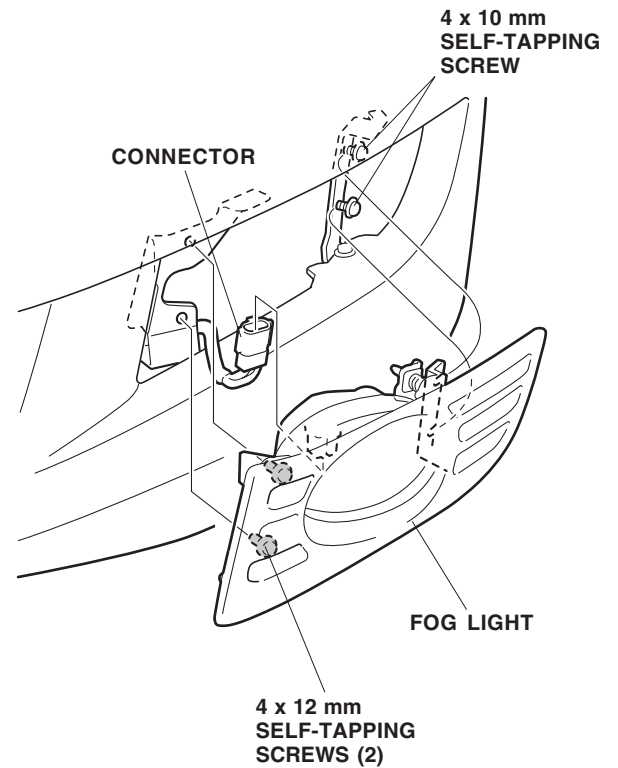

2. Remove the bulb.

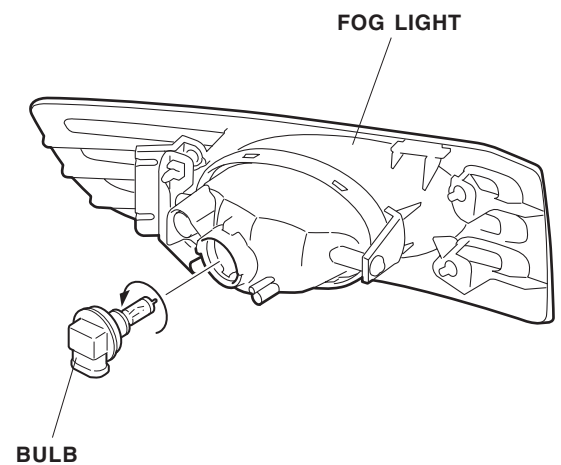

3. Install the new bulb into the socket.
- Use only a genuine Honda halogen light bulb of specified wattage.

Rating: 12V 55W H11 Halogen Light Bulb
P/N 33165-S5A-003

- Do not touch the bulb. Oily or greasy substances on the bulb can shorten its service life due to the heat produced when the bulb is turned on. If the bulb is accidentally touched, wipe it clean with a soft cloth that has been dampened with a denatured alcohol or a mild detergent solution.
- Align the tab on the fog light with the cutout in the bulb when installing the new bulb. If not aligned, the fog light may annoy oncoming drivers.

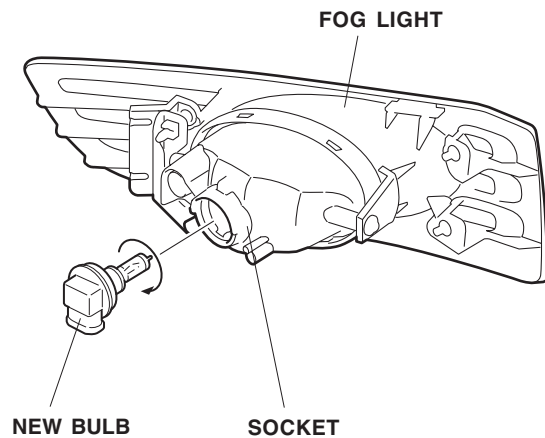

4. Reinstall the removed parts in the reverse order of removal.
- Check that the wire harnesses are not pinched.
 - Be sure to tighten the self-tapping screw.
5. Check the operation of the fog light; adjust the aiming if necessary.

CIRCUIT DIAGRAM

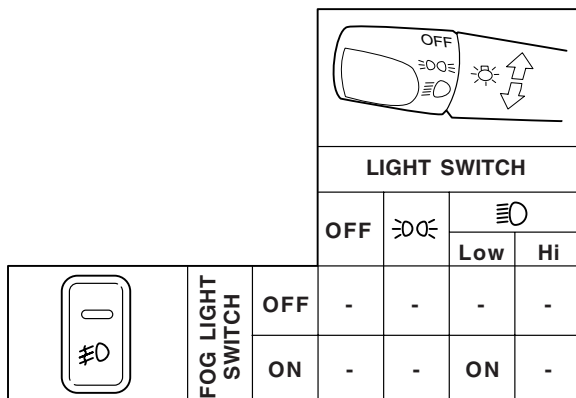
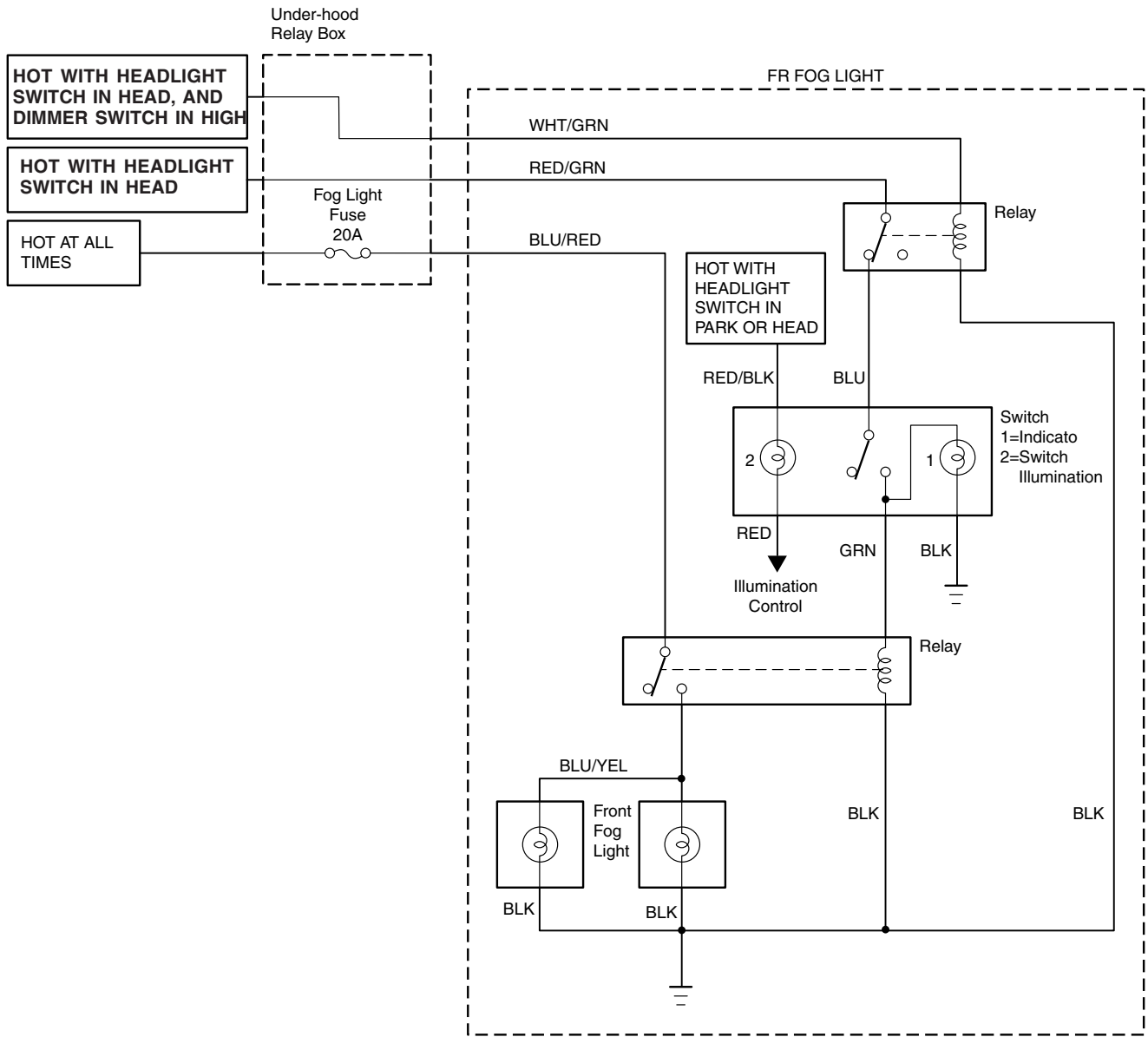

BLK	BLACK	BRN	BROWN
YEL	YELLOW	ORN	ORANGE
BLU	BLUE	PUR	PURPLE
GRN	GREEN	NAT	NATURAL
RED	RED	PNK	PINK
WHT	WHITE	GRY	GRAY
LT BLU	LIGHT BLUE	LT GRN	LIGHT GREEN