



INSTALLATION INSTRUCTIONS

ENGINE BLOCK HEATER P/N 08T44-S5B-100	Accessory	Application ACCORD (L4) 2- AND 4- DOOR	Publications No. All 24384
			Issue Date AUG 2002

PARTS LIST

Engine block heater

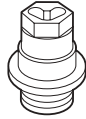

Aluminum washer



Heater harness

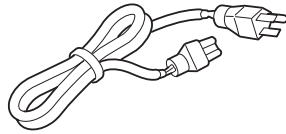

Protective cap

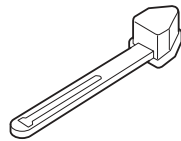

20 Wire ties
(7 Not used)

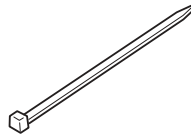

TOOLS AND SUPPLIES REQUIRED

- Phillips screwdriver
- Ratchet
- 24 mm Socket
- Torque wrench
- Diagonal cutters
- Coolant (Honda Antifreeze/Coolant only, in a 50/50 mixture with water)
- 8 mm Allen socket
- White marker
- Tape measure

NOTE

- Always use Honda Antifreeze/Coolant. Using a non-Honda coolant can result in corrosion, causing the cooling system to malfunction or fail.
- To avoid burning out the element, do not operate the engine block heater before it is installed in the vehicle and before you add coolant.

INSTALLATION

Customer Information: The information in this installation instruction is intended for use only by skilled technicians who have the proper tools, equipment, and training to correctly and safely add equipment to your car. These procedures should not be attempted by "do-it-yourselfers."

1. Allow the engine and all cooling system components to cool down.
2. Place a clean drain pan under the radiator drain plug, then remove the drain plug from the bottom of the radiator to drain the coolant. Remove the radiator cap to increase the flow.

NOTICE Radiator coolant will damage paint. Quickly rinse any spilled coolant from painted surfaces.

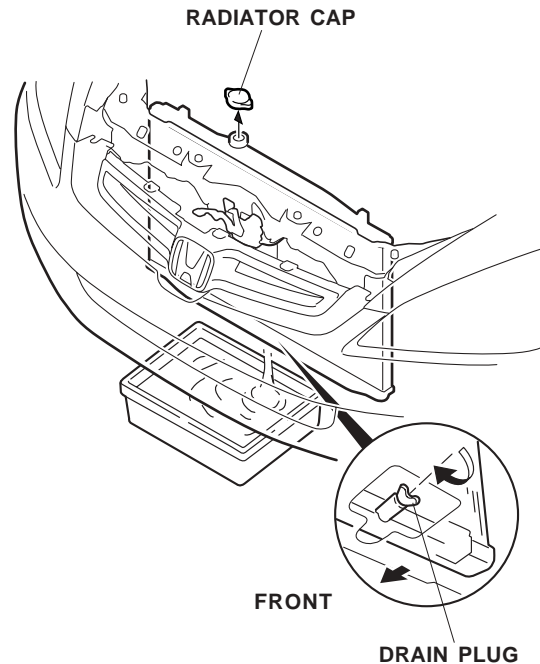

- Remove the drain plug from the rear side of the block. Coolant remaining in the engine jackets will flow out of the hole when the plug is removed. Retain the plug, and it will be used if the engine block heater is removed.

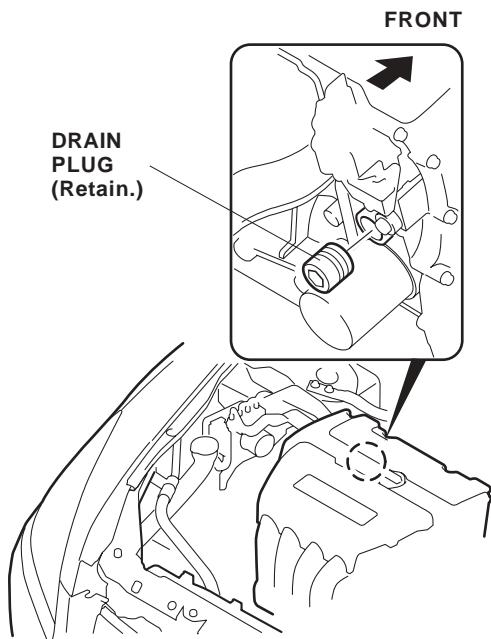

- Install the engine block heater with the aluminum washer into the hole using a 24 mm socket. Torque the engine block heater to 60 N·m (44 lb-ft).

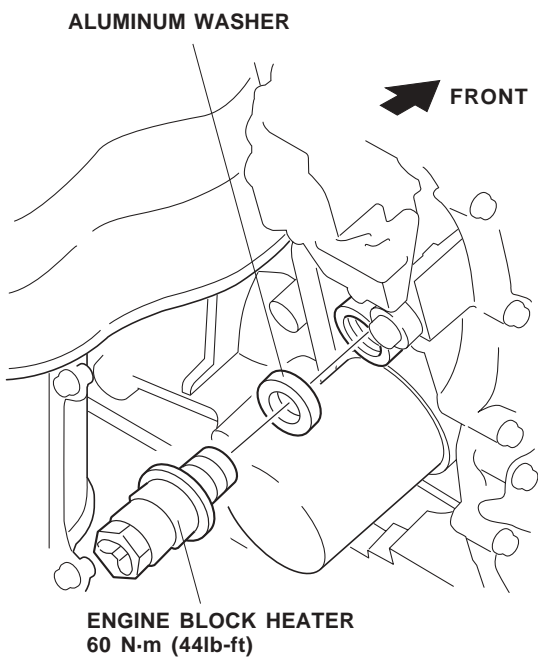

- Using a white marker and tape measure, mark the heater harness at the measurement shown.

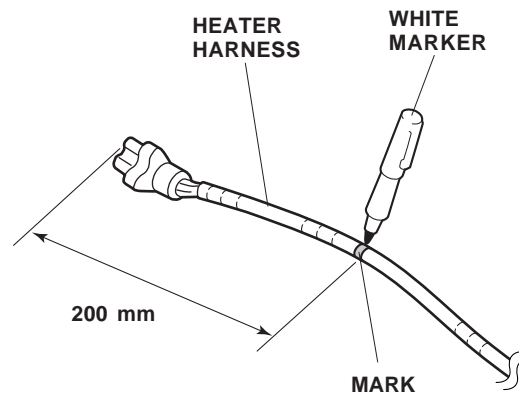

- Plug the heater harness connector into the engine block heater. Route the heater harness along the vehicle harness and secure it to the vehicle harness with one wire tie at the white mark.

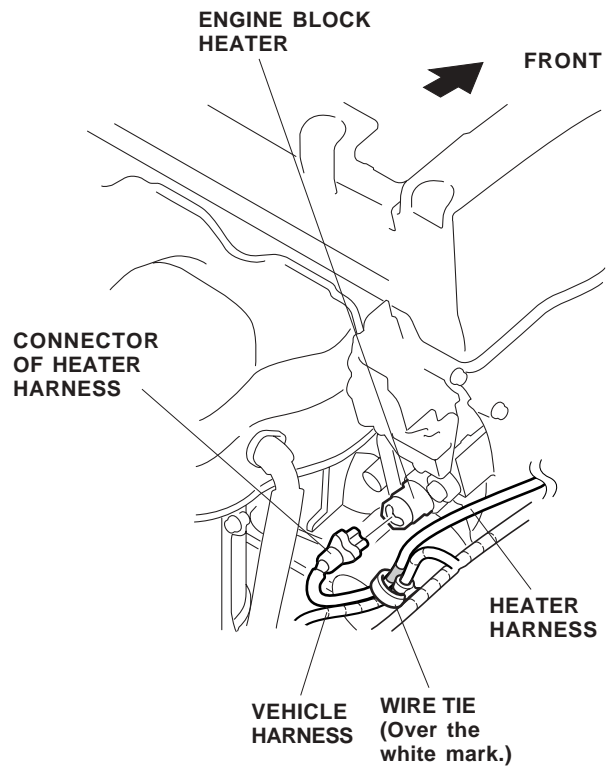

7. Route the heater harness alongside the vehicle harness, and secure the heater harness to the vehicle harness and frame with six wire ties.

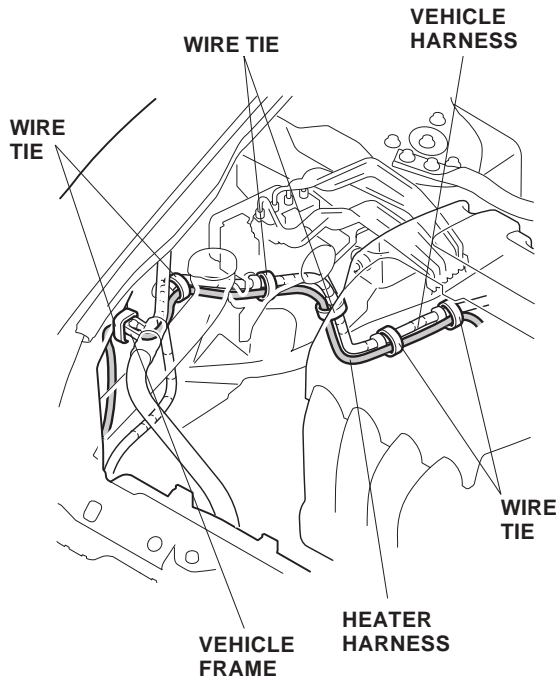

8. Continue routing the heater harness along the vehicle harness through the front bulkhead to the right side of the radiator. Secure the heater harness to the vehicle harness with the two wire ties positioned on the inside of the front bulkhead.

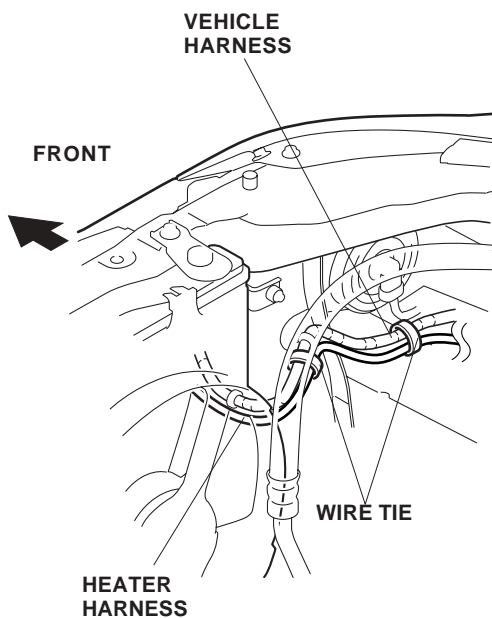

9. Secure the heater harness to the vehicle harness with the two wire ties positioned on the outside of the front bulkhead.

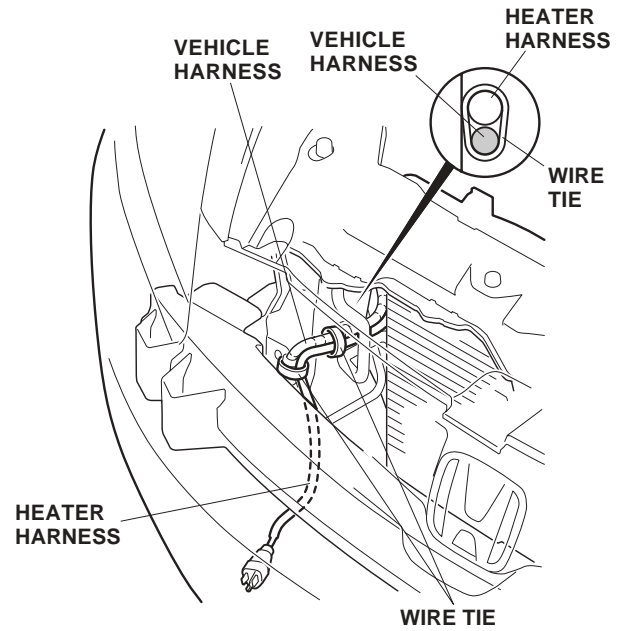

10. Secure the heater harness to the bumper grille with two wire ties.

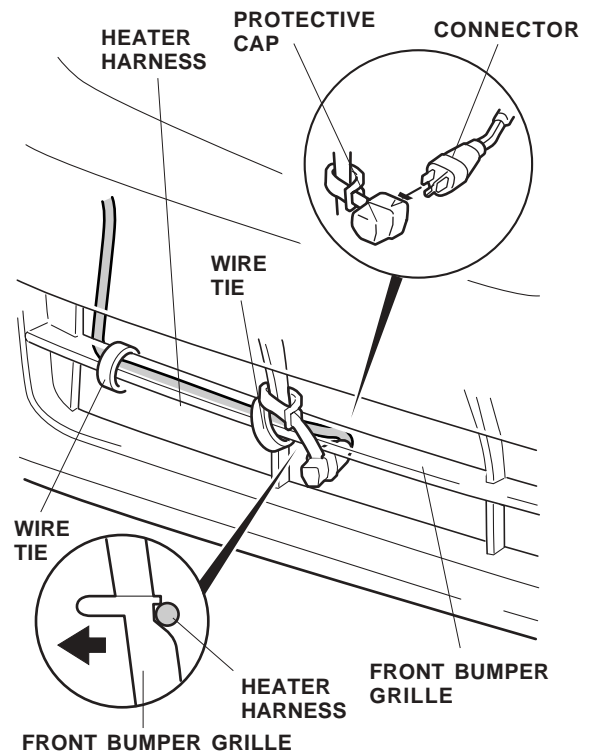

11. Attach the protective cap to the grille, and plug the connector of the heater harness into the protective cap.

12. Reinstall the radiator drain plug.
13. Fill the system with the recommended coolant. Follow the instructions described in the service manual to fill and bleed the cooling system.
14. Check the coolant reservoir for correct level and check the cooling system for signs of leakage. Repair as necessary.
15. Check that the heater harness is routed properly and all connectors are plugged in.
16. Put the drain plug (removed in step 3) in the glove box.