



INSTALLATION INSTRUCTIONS

Accessory
in-VEHICLE ENTERTAINMENT SYSTEM (WITH MOONROOF)

Application
ACCORD 4-DOOR

Publications No.
All 24046
Issue Date
AUG 2002

Attachment Kit P/N 08B23-SDA-100A

i-VES harness

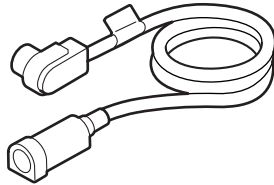

Subharness

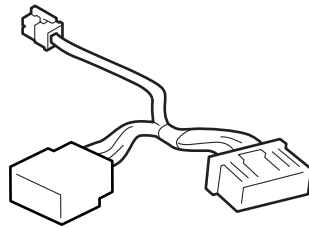

DIN Harness

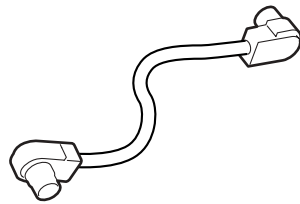

Room light harness

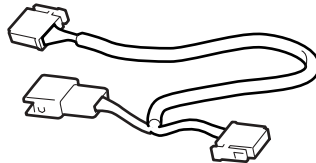

Room light gasket

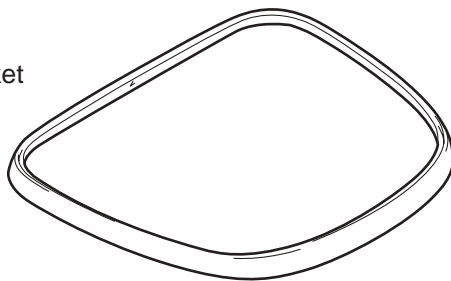

Template

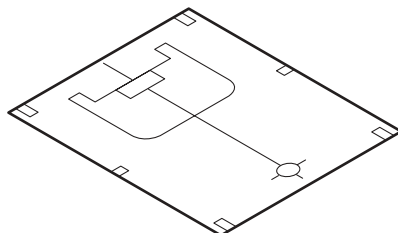

Monitor bracket

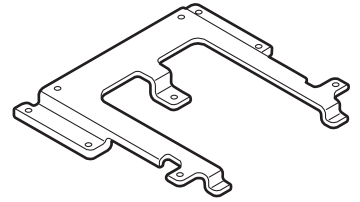

2 Washer-screws, 5 x 16 mm



2 Washer-screws, 5 x 25 mm



5 Square-neck bolts

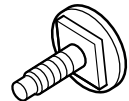

5 Flange nuts, 4 mm



16 Wire ties

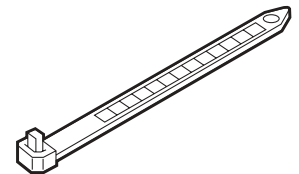

Wire ties with clip

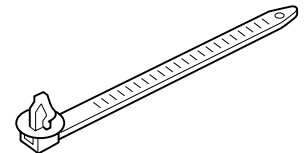

6 Cushion tapes

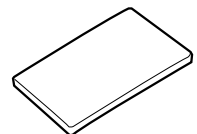

Monitor Kit :
P/N 08A23-2E1-010

Monitor console

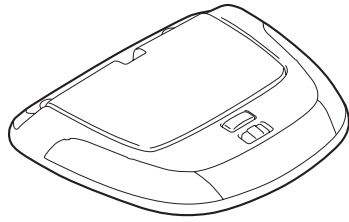

DVD player

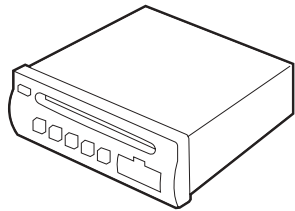

FM modulator

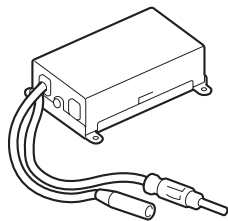

Remote controller

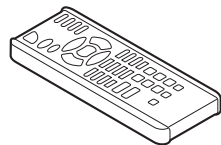

2 Headphones

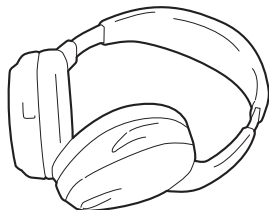

5 Washer-screws, 5 x 8 mm



2 Screw caps



Owner's Manual

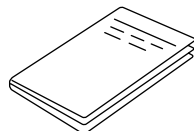

Player Attachment Kit :
P/N 08B06-SDA-100

Left player bracket



Right player bracket



Left player subbracket

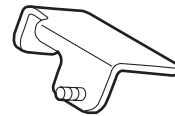

Right player subbracket

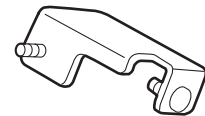

Player base-bracket

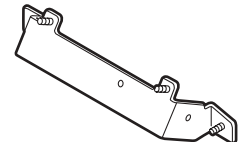

Player panel

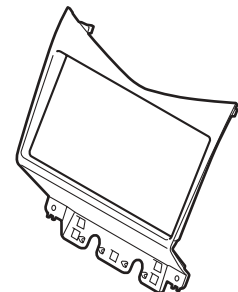

Pocket

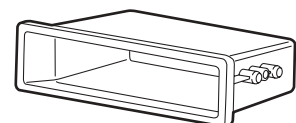

Bus cable
(Not used)

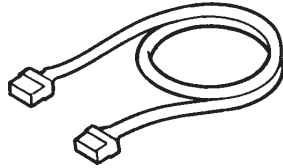

2 Latches



6 Flange nuts, 6 mm



2 Washer-bolt, 6 x 16 mm



2 Self-tapping screws, 4 x 8 mm



2 Grommet screws



2 Wire ties

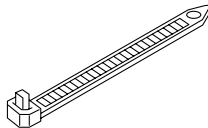

EPT sealer

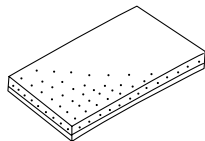

TOOLS AND SUPPLIES REQUIRED

- Phillips screwdriver
- Flat-tip screwdriver
- 10 mm Combination wrench
- Ratchet
- 7 mm, 10 mm and 12 mm Socket
- Torque wrench
- Utility knife
- File
- Isopropyl alcohol
- Masking tape
- Piece of steel wire
- Shop towel
- Electrical tape
- Scissors
- Hook tool

Illustration of the components installed on the car

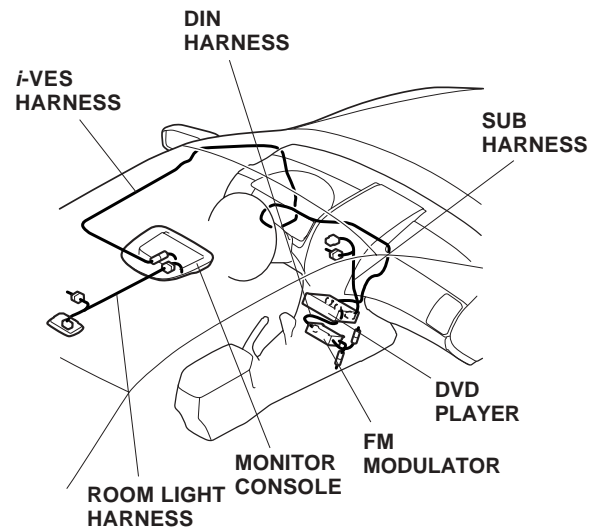

INSTALLATION

Customer Information: The information in this installation instruction is intended for use only by skilled technicians who have the proper tools, equipment, and training to correctly and safely add equipment to your car. These procedures should not be attempted by “do-it-yourselfers.”

1. Make sure you have the anti-theft code for the radio, then write down the frequencies for the preset buttons.
2. Disconnect the negative cable from the battery.

- Using the Scissors, cut out the marked areas from the template along the lines.

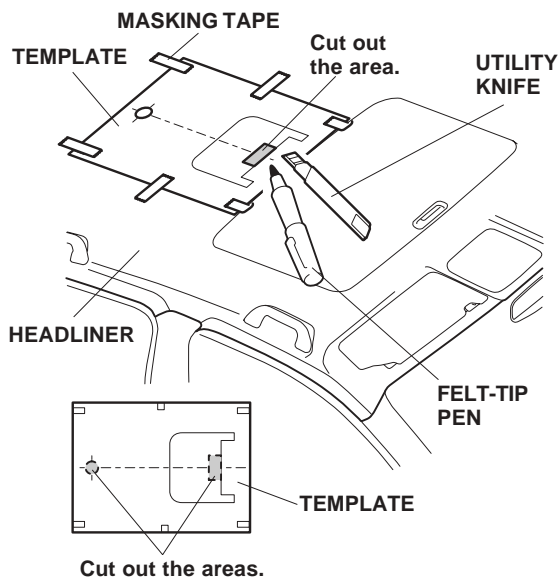

- Position the template on the headliner with the round cutout over the plug and the front edge against the sunroof opening. Tape the template to the headliner using strips of masking tape.
- Using the felt-tip pen, mark the headliner along the edges of the square cutout in the template. Using the utility knife, cut out the marked areas of the headliner.
- Reaching through the opening you just made in the headliner, mark the vehicle frame at the center line of the template.

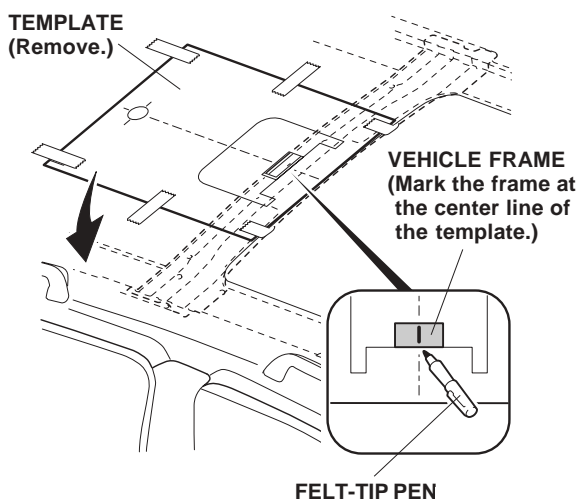

- Remove the template from the headliner.

- Using scissors, cut out the marked area from the template, then align the center line of the template with the mark you made in step 6. Tape the template to the headliner again.

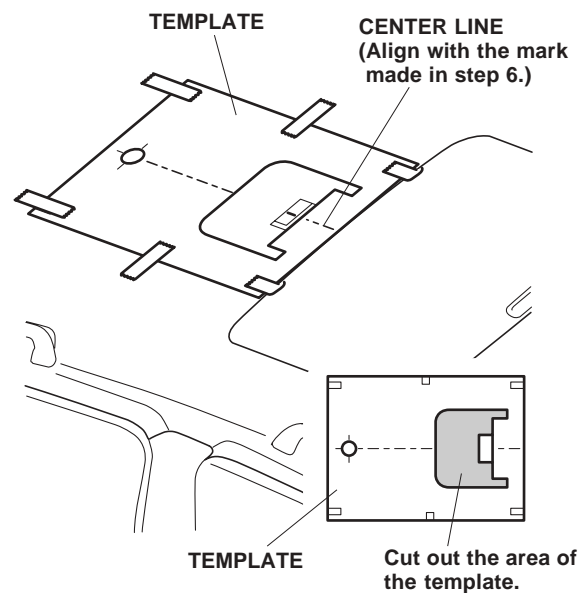

- Using the felt-tip pen, mark the headliner around the edges of the template where you just cut.

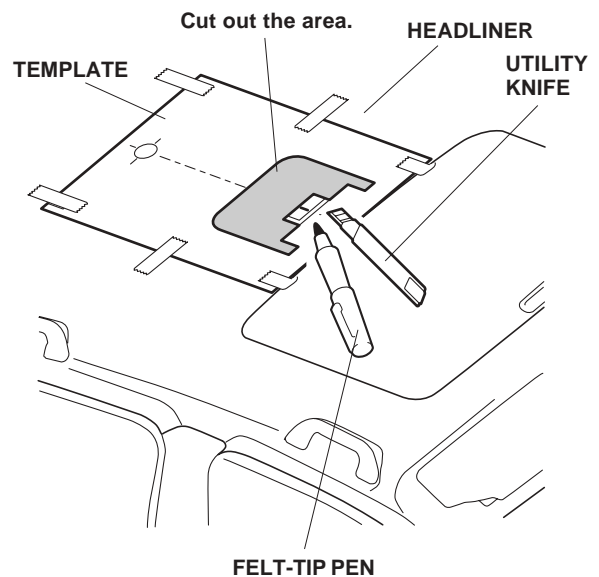

- Using the utility knife, cut out the marked area of the headliner. Remove the template.

11. Remove the trim ring.

M/T Model

- Squeeze the plastic clip and pull down on the shift boot. Remove the shift knob by turning it counterclockwise.

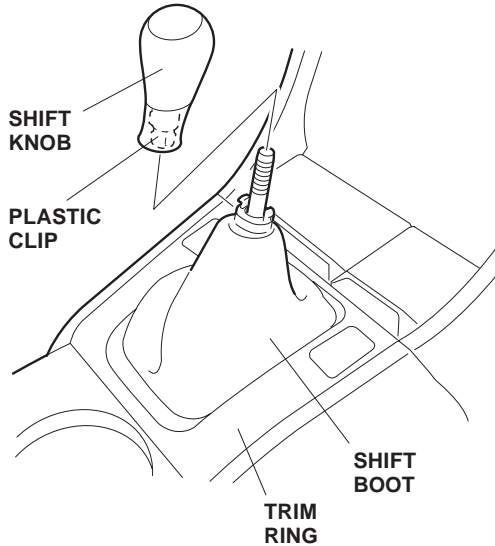

- Gently pry up on the trim ring to release the six clips.
- Unplug the two seat heater connectors (if equipped), and remove the trim ring.

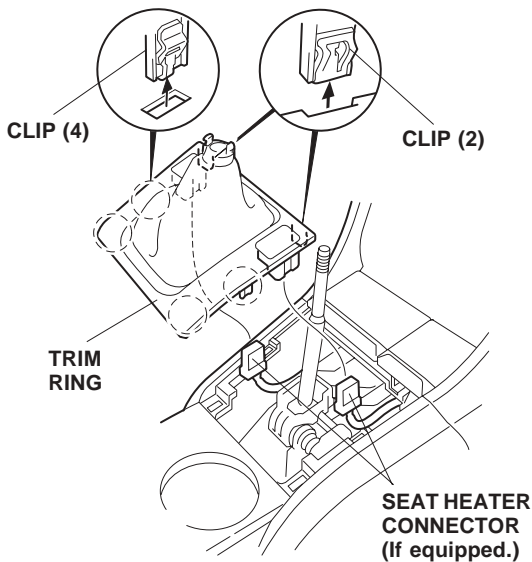

A/T Model

- Gently pry up on the trim ring to release the six clips
- Unplug the two seat heater connectors (if equipped), and remove the trim ring.

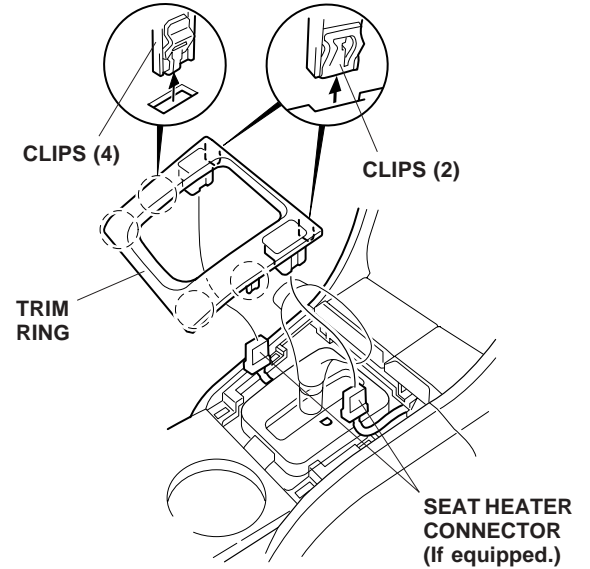

12. Remove the dashboard center holder:

- Open the coin pocket lid and remove the coin pocket.
- Remove the two self-tapping screws.
- Gently pull out on the dashboard center holder to release the two retaining clips, unplug the vehicle connector, and remove the center holder.

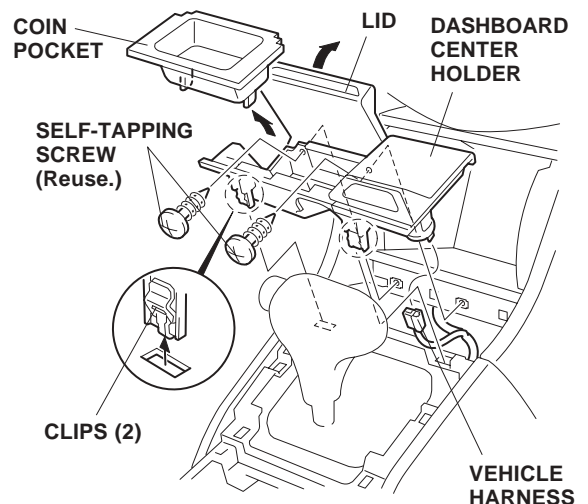

With Ashtray

- Open lid and remove the ashtray.
- Remove the two self-tapping screws.
- Gently pull out on the two retaining clips, unplug the cigarette lighter harness connector, vehicle connector, illumination bulb, and remove the center holder.

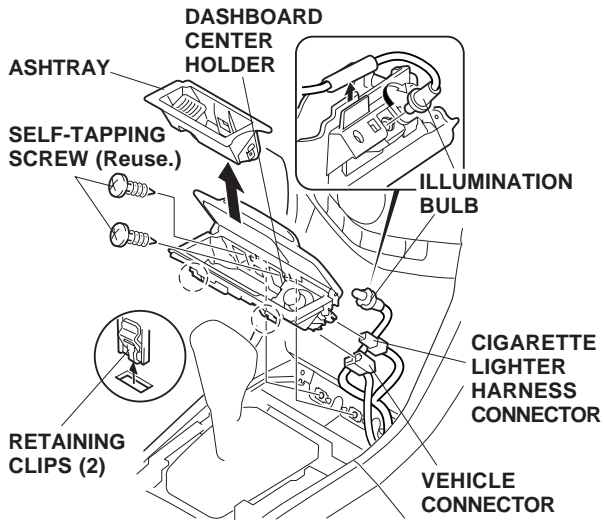

13. Remove the pocket:

- Apply masking tape to the edge of the center panel.
- Remove the two self-tapping screws.
- Push in on the bottom of the lid, then pull out on the top by inserting the end of a hook tool between the pocket and center panel, and pulling it to out toward you to release the two retaining clips.

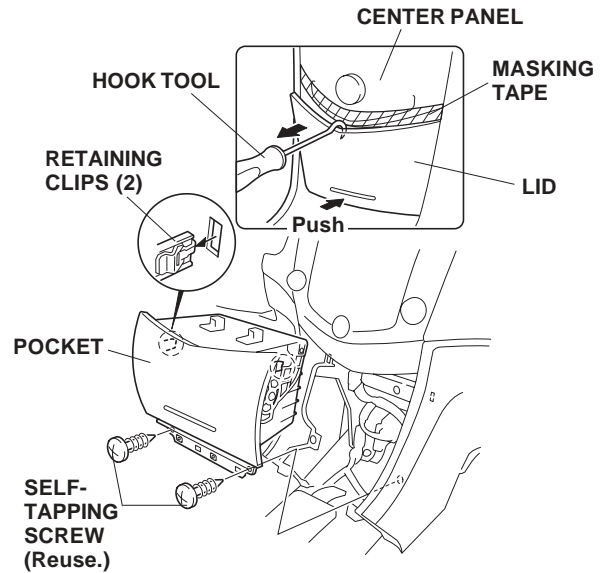

14. Remove the right and left inner covers (one hook and one clip for each cover).

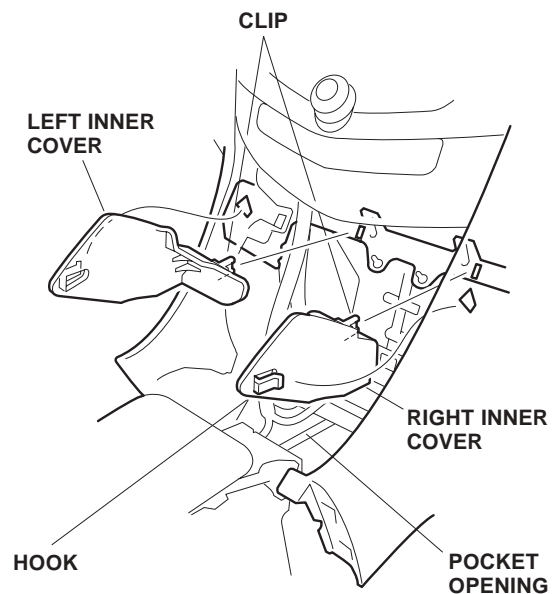

15. Remove the center dashboard upper cover.

- Carefully insert a flat-tip screwdriver wrapped with protective tape into the slots on both sides of the upper cover, then pull out each side of the panel back to detach the clips.

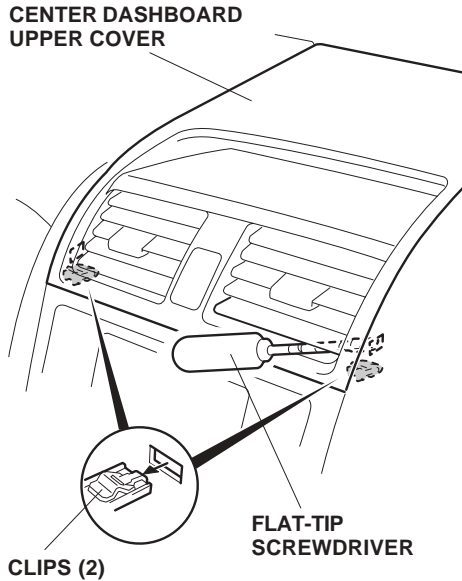

- Push the hazard warning switch bottom. Carefully insert a flat-tip screwdriver into the slot at the bottom, then pry up the middle portion of upper panel by releasing the center clip.

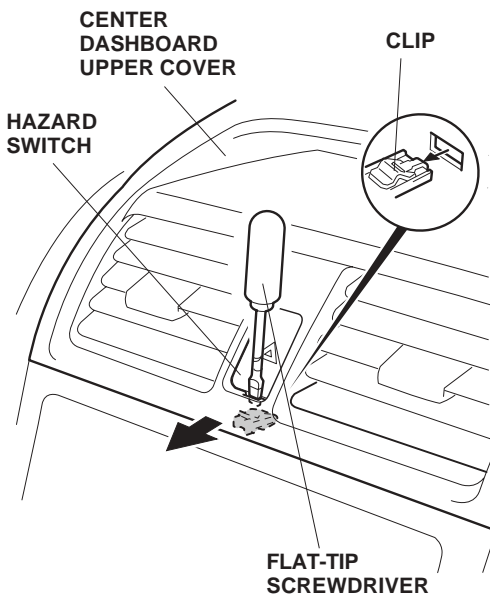

- Using a hook tool, reach inside the vent and locate the small opening on each side. Gently pull out on the dash to release the eight clips.
- Remove the center dashboard upper cover by removing the two vehicle clips and unplugging the vehicle connector(s).

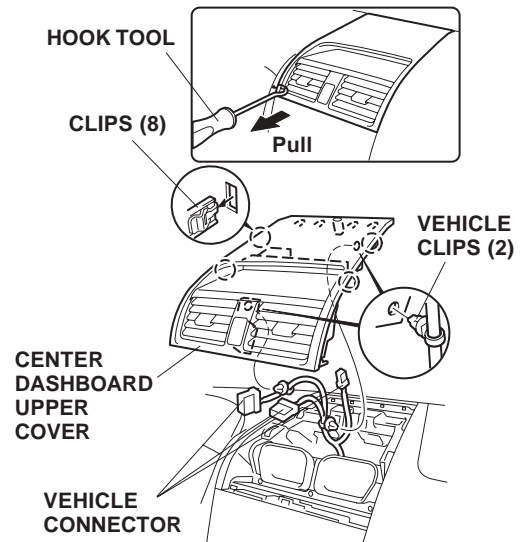

16. Remove the center panel (two bolts, three self-tapping screws, and pull the center panel out toward you to release the five clips).

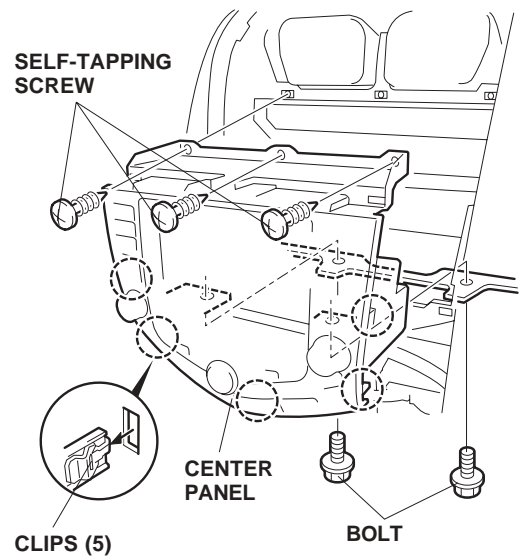

17. Remove the driver's dashboard lower cover.

- Remove one self-tapping screw.
- Release the four clips on the left side first by gently pulling out on the driver's dashboard lower cover.
- After releasing the four clips, insert the tip of the screwdriver between the clip and the dashboard frame. Gently twist the screwdriver to release each clip.
- Unplug the vehicle connector, and remove the lower cover.

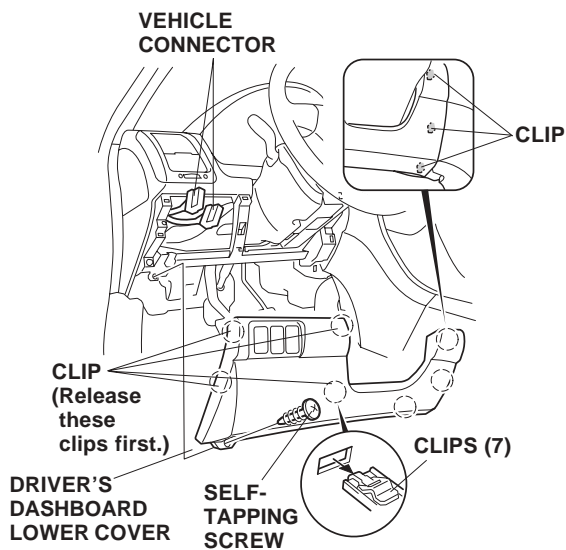

18. If equipped, remove the driver's dashboard under cover (release the three retaining clips, one pin and one holder).

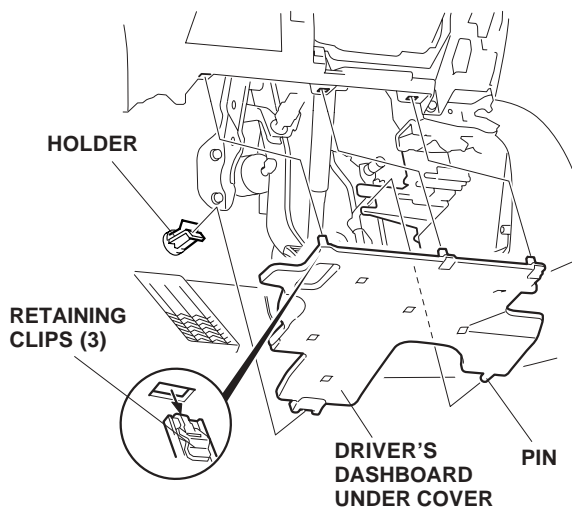

19. Pry up on the four retaining tabs that fasten the cap to the left front door sill and remove the cap.

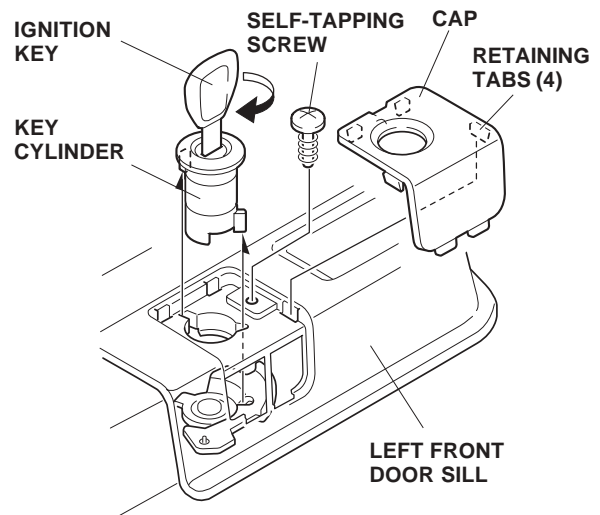

20. Remove the self-tapping screw. Insert the ignition key into the key cylinder and turn it clockwise until it will no longer turn. Using a flat-tip screwdriver, pry up on the key cylinder and remove it from the left front door sill.

21. Remove the left front door sill (five clips and two retaining tabs).

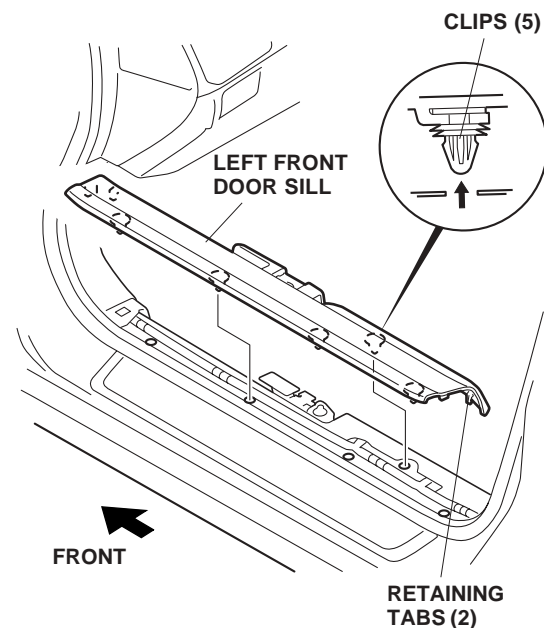

22. Remove the left rear door sill (four clips).

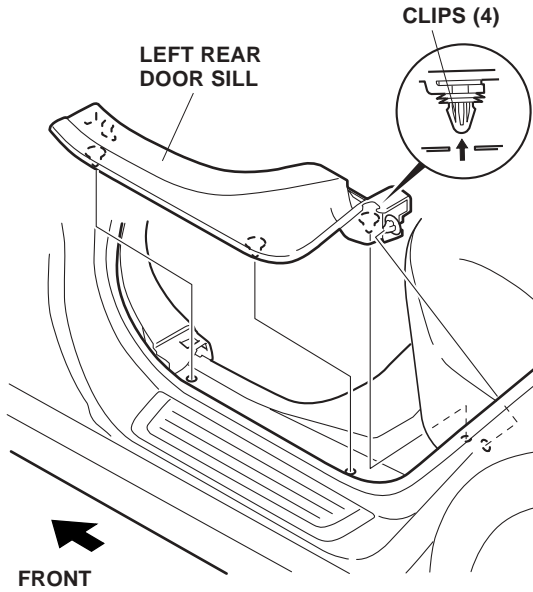

23. Release the center pillar upper anchor cover (three tabs). Remove the left center pillar upper anchor bolt.

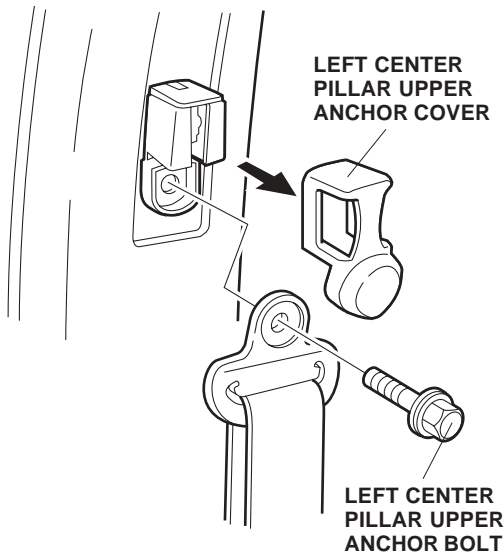

24. Remove the left center pillar lower anchor bolt.

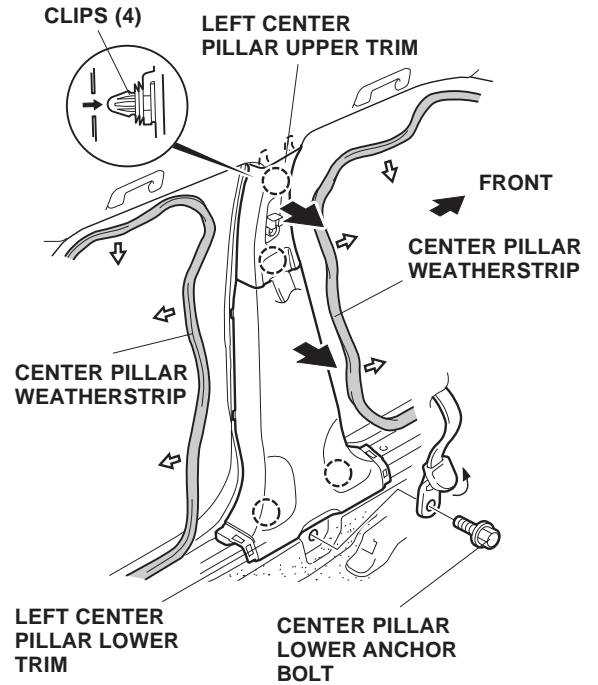

25. Remove the center pillar weatherstrip. Pull the left center pillar lower trim and left center pillar upper trim out toward you to release the four clips, and remove the upper and lower trims.

26. Remove the weatherstrip. Pull the left front pillar trim out toward you to release the two clips, and remove the left front pillar trim.

With SRS System Shown

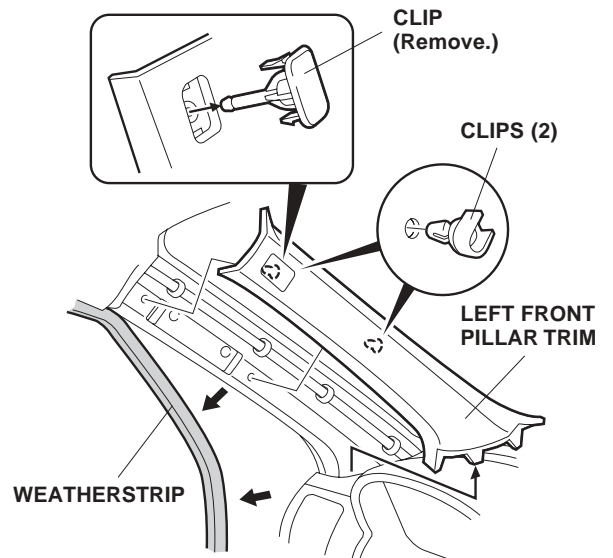

27. Remove the left and right lens from roof console (four retaining tabs).

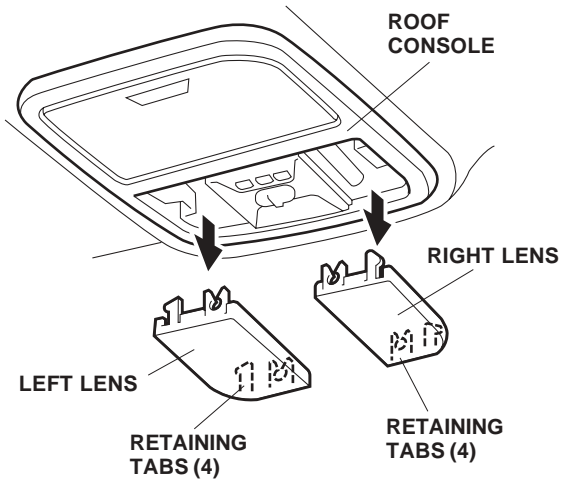

28. Remove the four bolts that fasten the roof console. Remove the roof console by pulling it out toward you, and unplugging the two vehicle connectors.

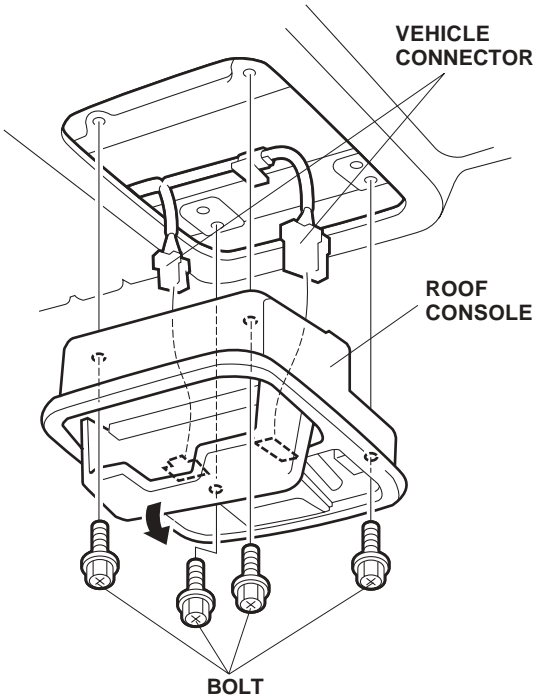

29. Remove the cap from the left sunvisor (four retaining tabs).

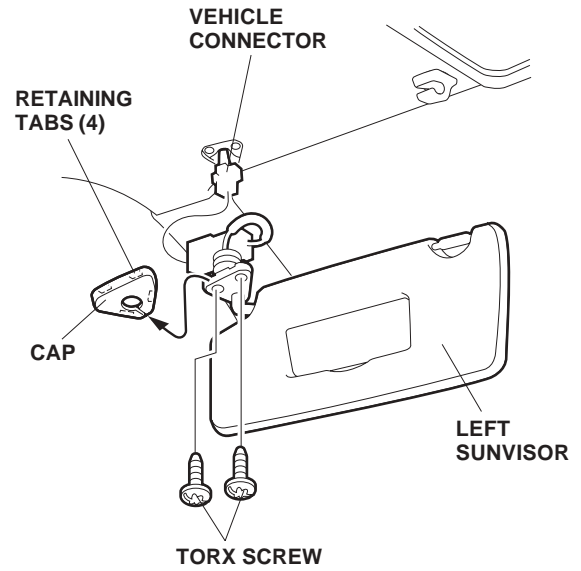

30. Remove the left sunvisor (two T25 torx screws, and unplug the connector).
31. Remove the two caps from the left front grab rail, and remove the grab rail (two bolts).

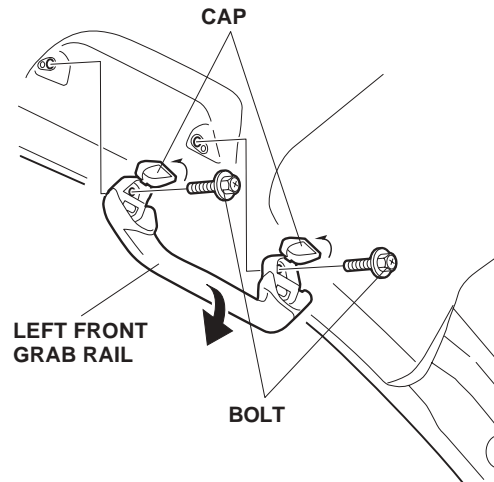

32. Remove the two caps from the left rear grab rail, and remove the grab rail (two bolts).

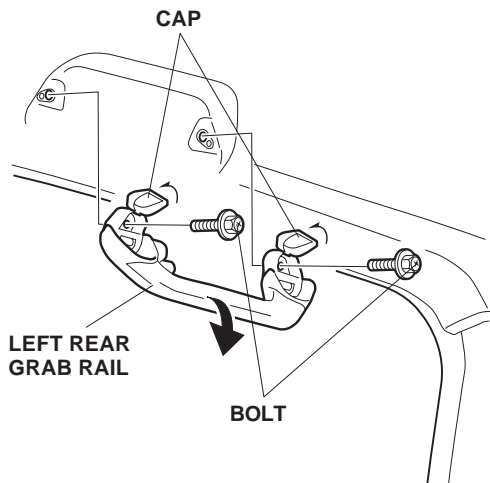

Routing the *i*-VES Harness/Monitor Harness and Installing the Monitor Console

33. Route the 90° end of the *i*-VES harness from the left front pillar trim opening to the dashboard lower cover opening.

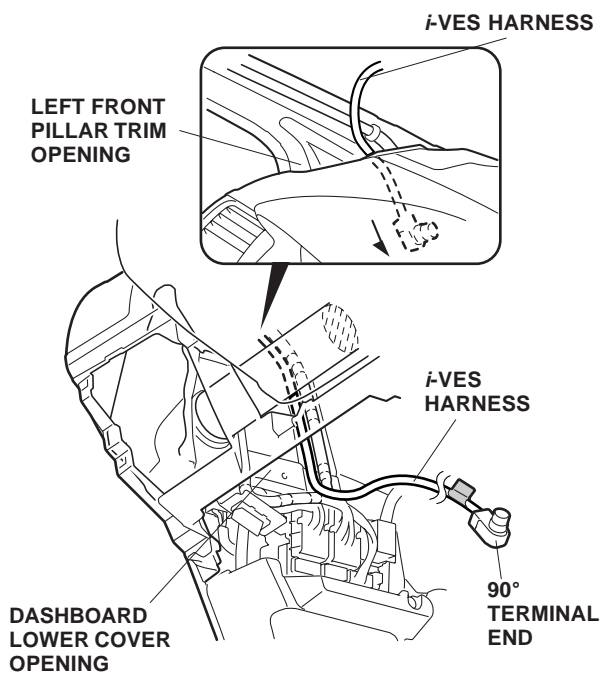

34. Continue routing the 90° end of the *i*-VES harness from the dashboard lower cover opening to the pocket opening on the driver's seat side.

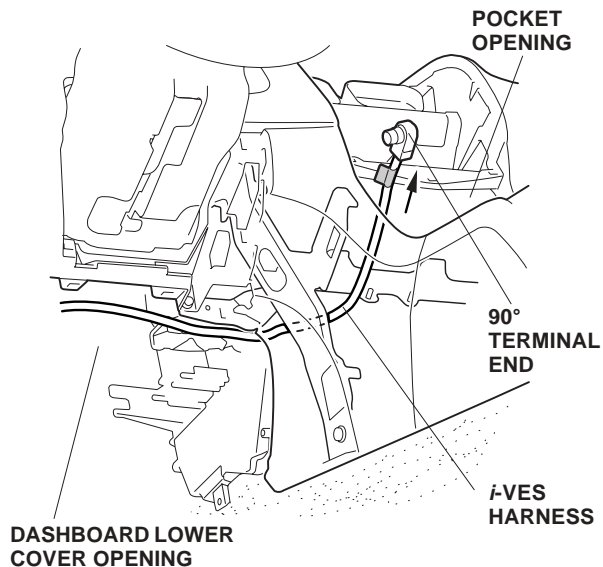

35. Remove the sunvisor holders. Using a flat-tip screwdriver, push the hook, and turn the holder 90°, then pull it out.

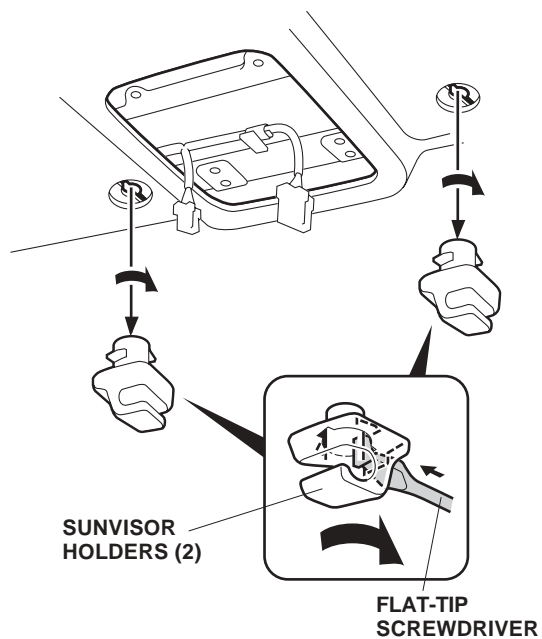

36. Route the *i*-VES harness up along the front pillar and under the headliner along side the vehicle harness as shown.

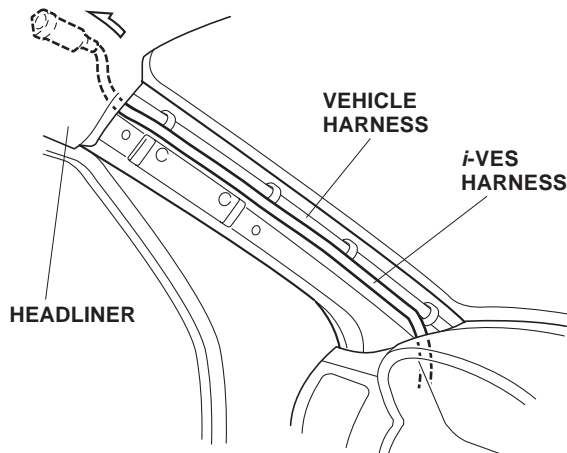

37. Continue routing the *i*-VES harness to the rear along the vehicle harness, and out of headliner opening you made, so that the distance between the headliner opening and *i*-VES harness terminal end is 370 mm.

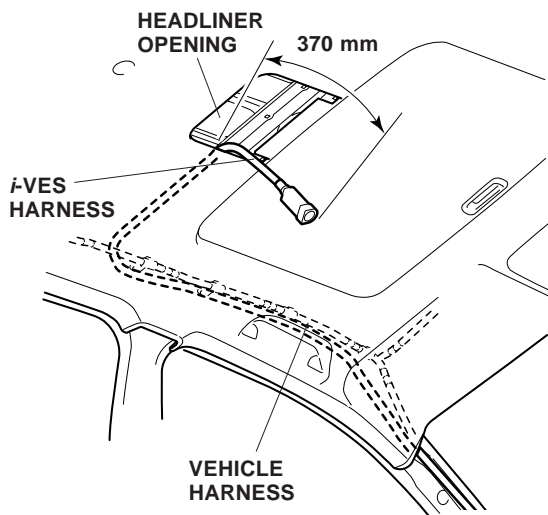

38. Release the rear interior light.

- Remove the lens (four retaining clips).
- Remove the two screws, lift out the light, unplug the connector, and remove the light.

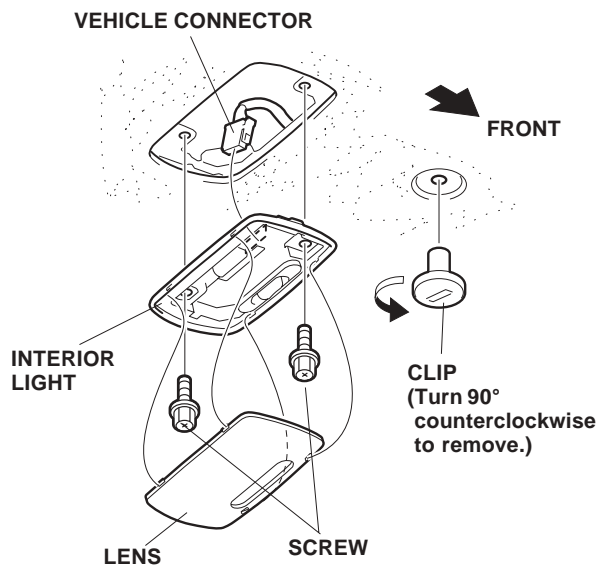

39. Remove the headliner clip by turning it 90° counterclockwise.
40. Route a piece of steel wire through the hole in the rear interior light opening and out through the cutout made in the headliner.

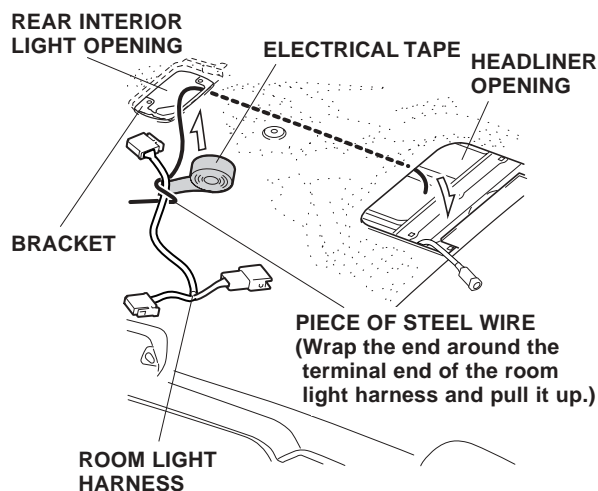

41. Wrap the end of the steel wire around the room light harness connector and secure with an electrical tape. Pull the room light harness up through the rear interior light opening and out through the headliner opening.

42. Plug the room light harness 3-pin connectors in between the rear interior light and vehicle 3-pin connectors.

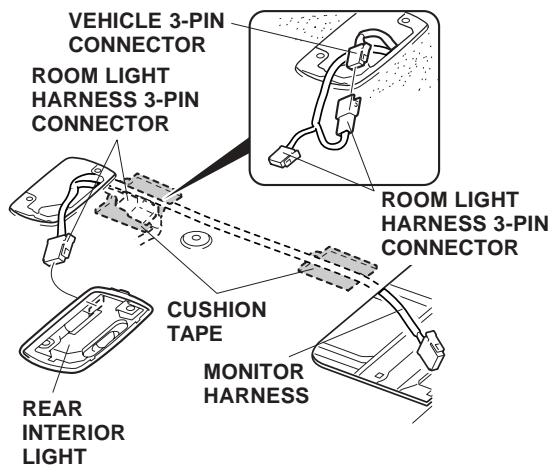

43. Using isopropyl alcohol, thoroughly clean the area where the two cushion tapes will attach. Secure the room light harness to the headliner with the two cushion tapes in the areas shown.
44. Reinstall the rear room light.
45. Slide the five square-neck bolts into the holes in the vehicle frame from the top down, Use strips of masking tape to hold the bolts in position. Do not remove the clip.

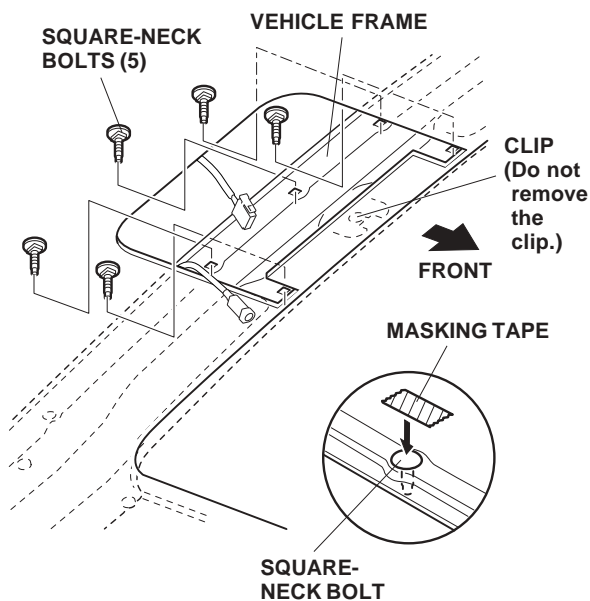

46. Install one collar over each square-neck bolt (use a small piece of masking tape to hold the collars), and install the monitor bracket and the 4 mm flange nuts.

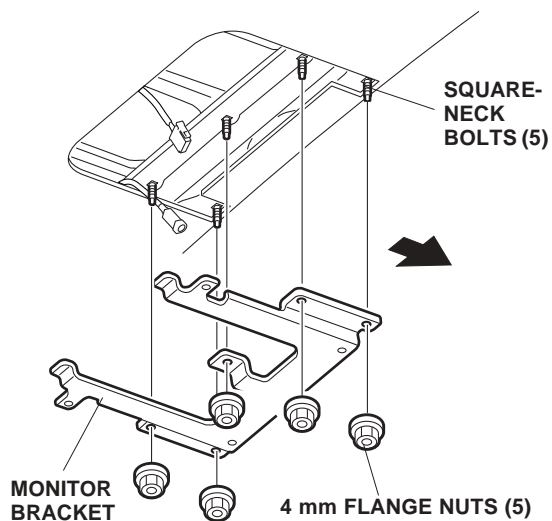

47. Remove the left and the right lenses from the monitor console, then install the monitor gasket on the console.

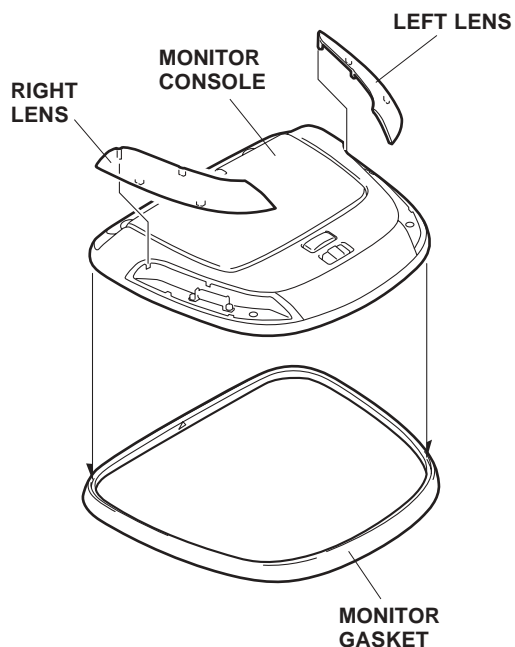

48. Connect the room light harness 3-pin connector and the *i*-VES harnesses terminal to the monitor console 3-pin connector and monitor console terminal.

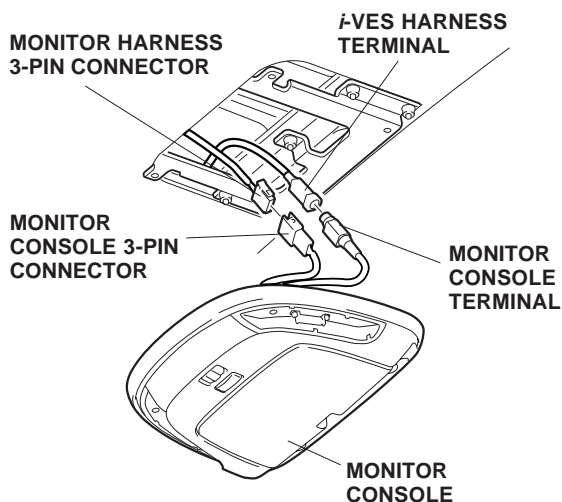

49. With an assistant holding the monitor console, thoroughly clean the area where the cushion tapes will attach, and where the monitor console terminal and the 3-pin connector will attach. Secure the 3-pin connectors and terminals you just connected to the underside of the vehicle frame with the cushion tape as shown.

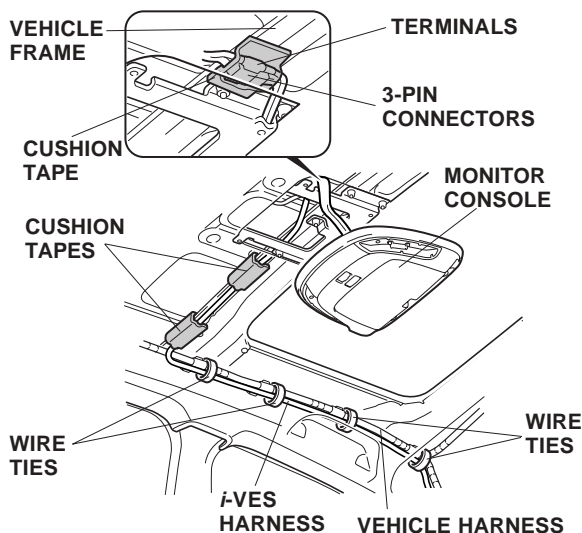

50. Secure the *i*-VES harness to the underside of the vehicle frame with the two cushion tapes.
51. Secure the *i*-VES harness to the vehicle harness with four wire ties in the areas shown.

52. Position the monitor console on the monitor bracket and install the two 5 x 16 mm washer-screws and the two 5 x 25 mm washer-screws. Install the two screw caps, then reinstall the left and right lenses. Do not pinch the *i*-VES harness and monitor harness between the monitor console and the monitor bracket.

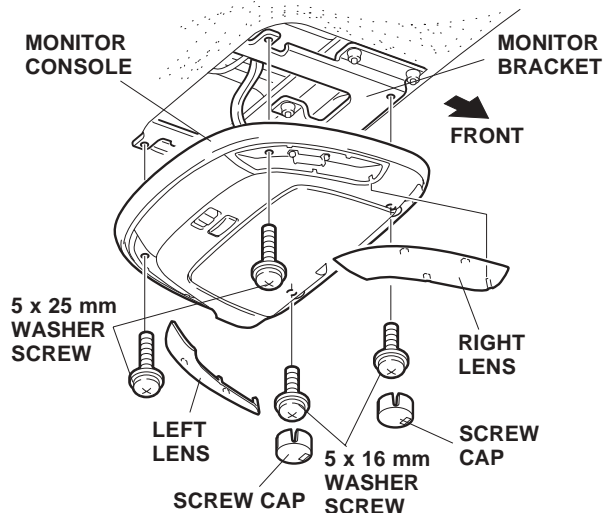

53. Along the front pillar, secure the *i*-VES harness to the vehicle harness with the four wire ties.

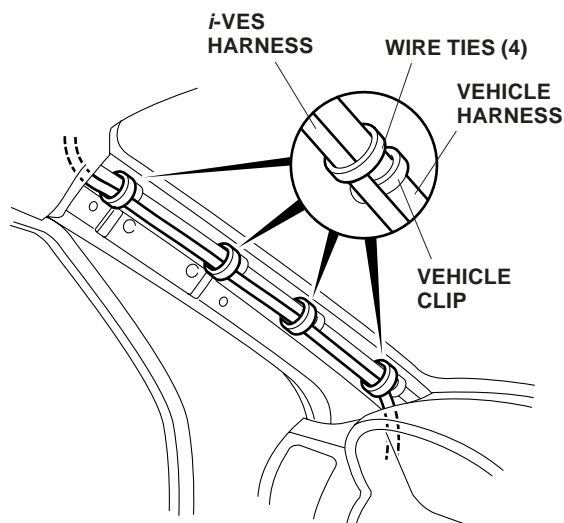

With day/night mirror

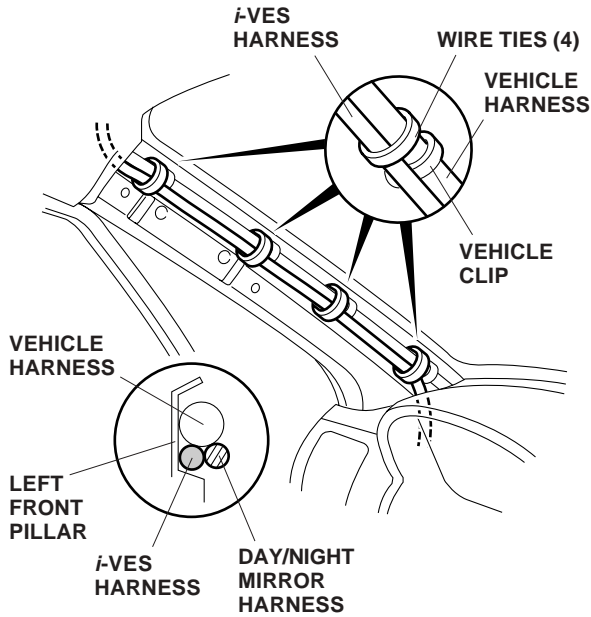

54. Near the fuse box by the dashboard lower cover opening, secure the i-VES harness to the vehicle harness with three wire ties in the areas shown.

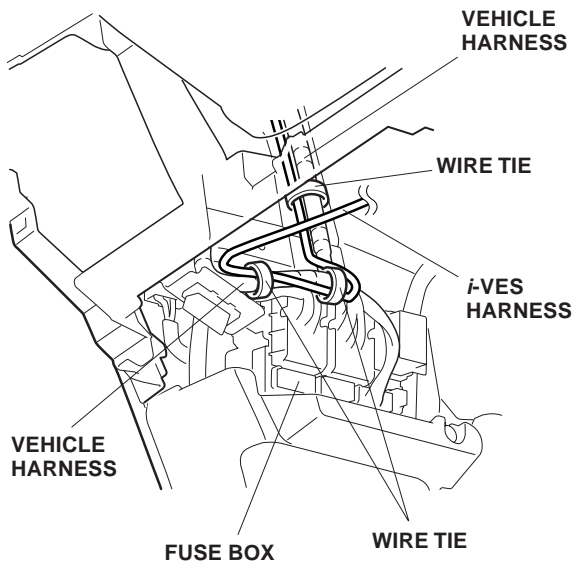

55. Continue securing the i-VES harness to the vehicle harness with three wire ties as shown.

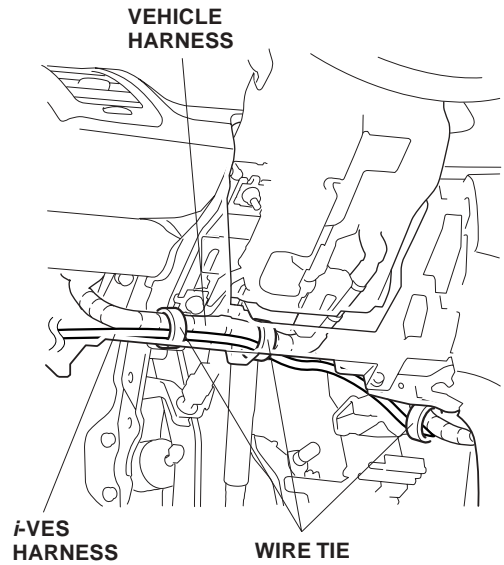

Installing the DVD Player

56. Unplug the vehicle 20-pin connector from the audio unit or the navigation unit. Route the sub harness as shown, and plug the subharness 20-pin connector into the vehicle 20-pin connector.

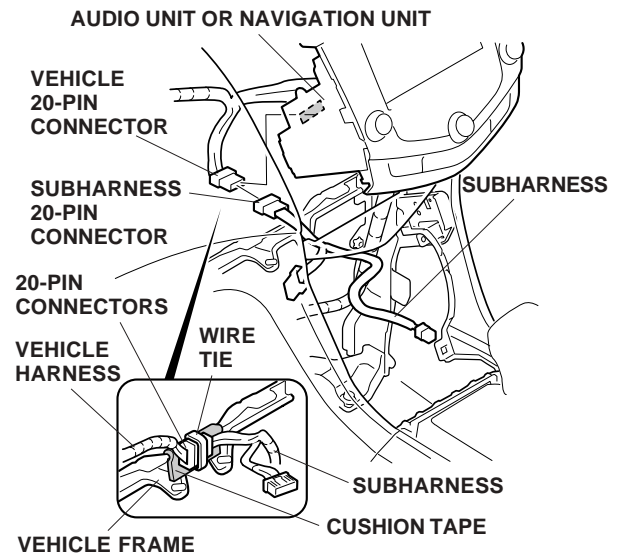

57. Using isopropyl alcohol on a shop towel, clean the area where the cushion tape will attach. Attach the cushion tape to the vehicle frame, and secure the connected 20-pin connectors to the vehicle frame with one wire tie.

58. Route the other end of the subharness behind navigation unit or audio unit, and plug the subharness 20-pin connector into the rear of the navigation unit or the audio unit, then reinstall the center panel. On navigation equipped vehicle, place the subharness connector between the vehicle bracket and air duct.

With Navigation System

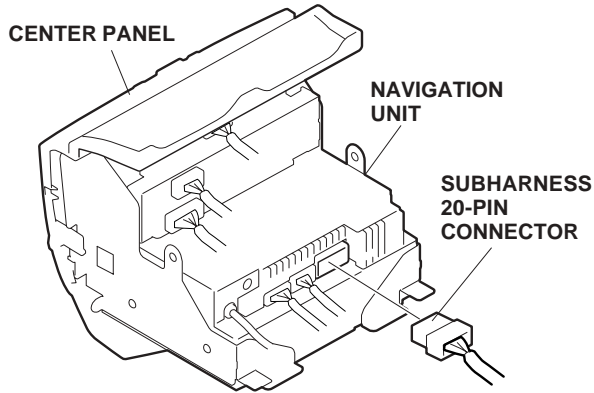

Without Navigation System

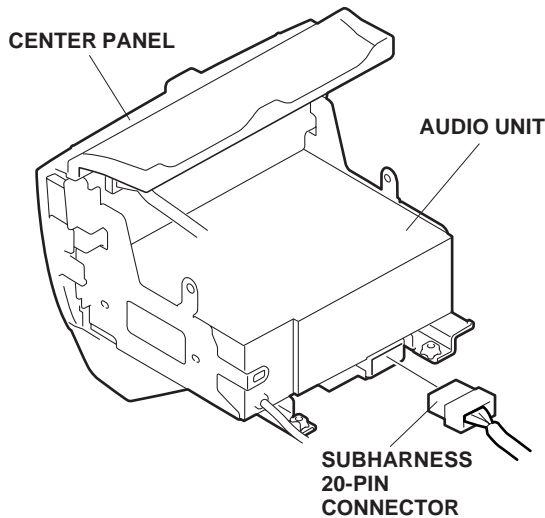

59. Remove the vehicle harness clip, and pull it out toward you.

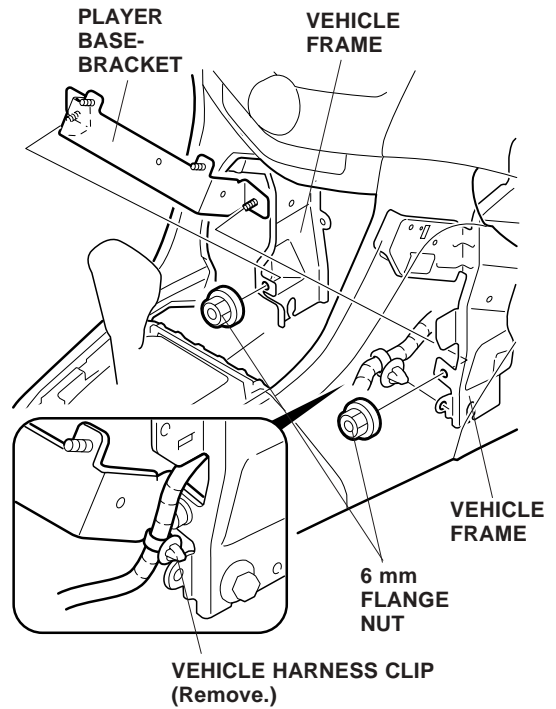

60. Install the player base-bracket to the vehicle frame, then install the two 6 mm flange nuts while holding the bracket firmly against the vehicle frame.
61. Position the FM modulator on the player base-bracket and install the 5 x 8 mm washer-screw.

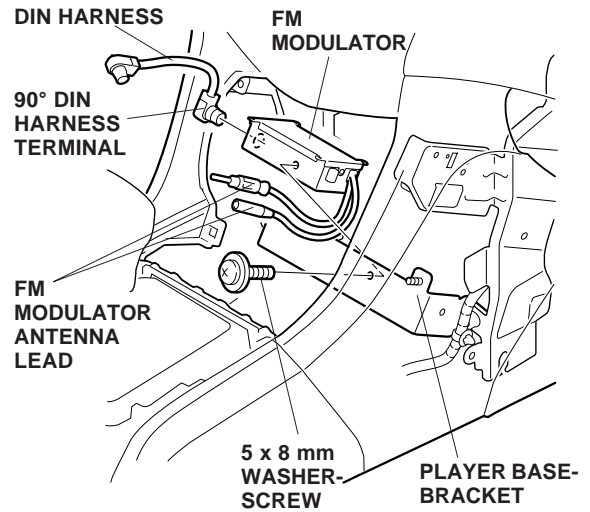

62. Plug the 90° DIN harness terminal into the FM modulator (Not the *i*-VES harness).

63. On the right of the dashboard opening, unplug the vehicle antenna leads and plug into the FM modulator antenna lead. Plug the FM modulator antenna lead into the vehicle antenna lead.

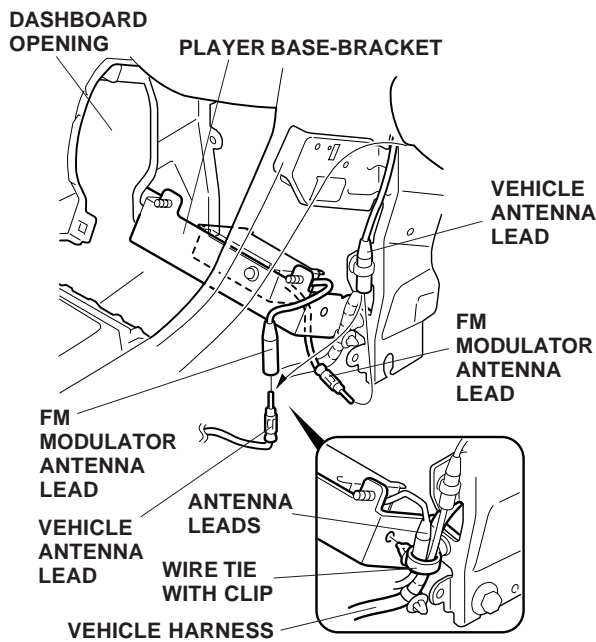

64. Wrap the FM modulator antenna lead and vehicle harness you removed with one wire tie with clip, and push the wire tie with clip into the hole in the player base-bracket.
65. Install the left and right player subbrackets into the holes in vehicle frame, then install the two 6 mm flange nuts while pushing the player sub-bracket upward.

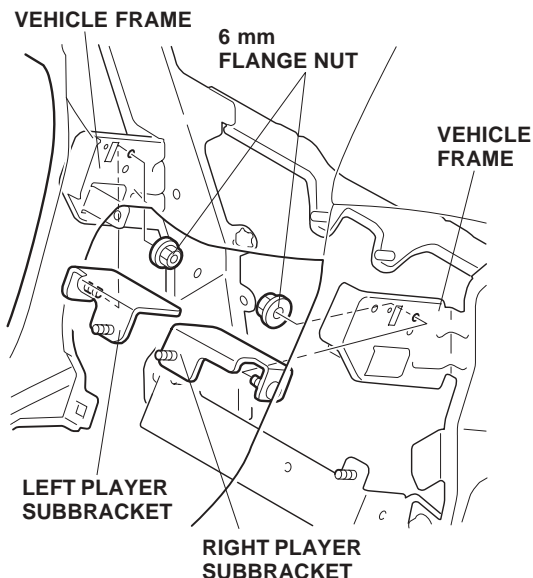

66. Align the end of the *i*-VES terminal with the end of the DIN harness terminal as shown, and loop the harnesses, and secure them with two wire ties.

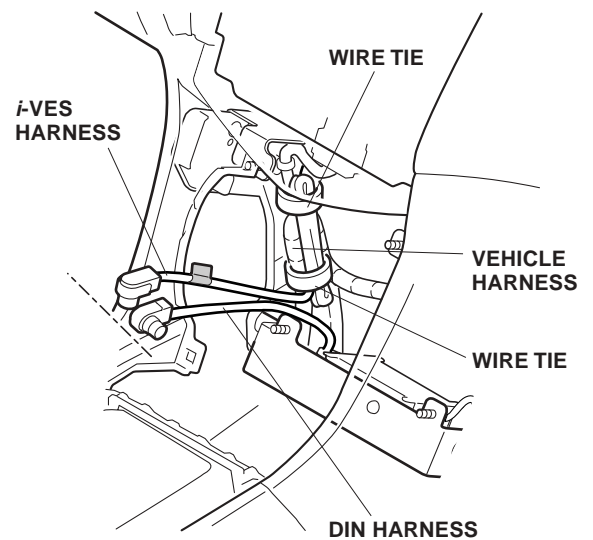

67. To protect the center panel, attach the masking tape to the center panel in the area shown.

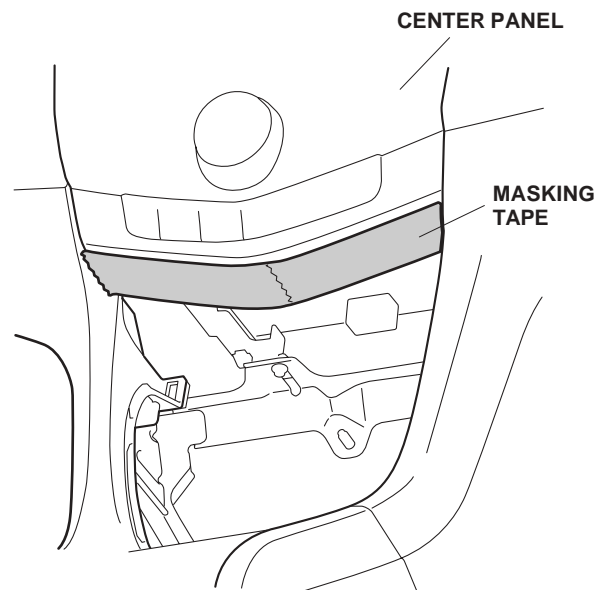

68. Get the pocket. Using a utility knife, cut the two lugs off from the pocket.

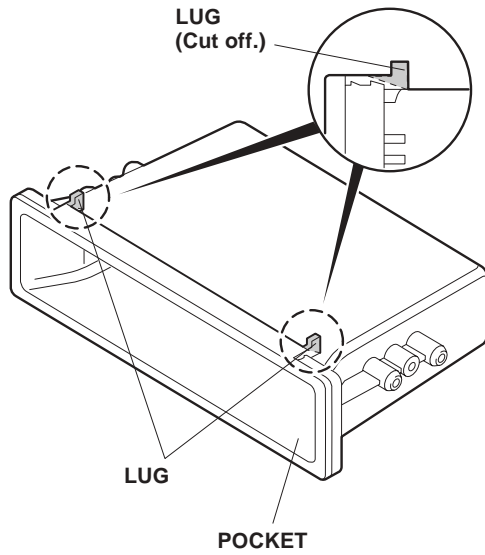

69. Install one latch to each to the left and right player brackets.
70. Position the DVD player and pocket on the left and right player brackets, and install four 5 x 8 mm washer-screws, and the two 4 x 8 mm self-tapping screws.

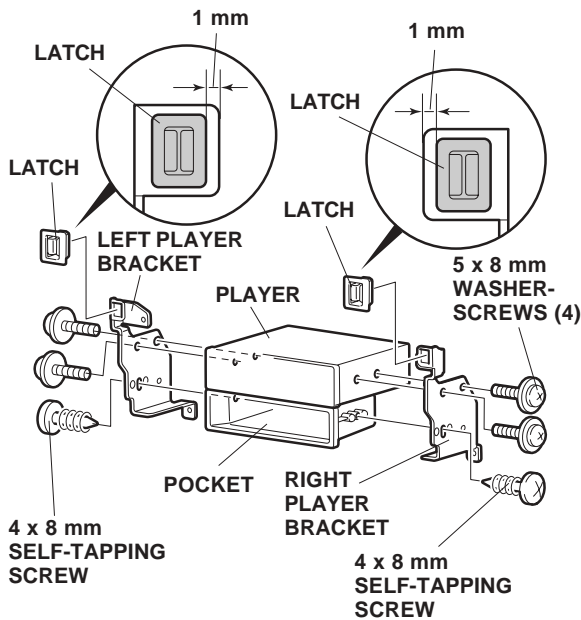

71. Plug the subharness 4-pin connector, the DIN harness terminal and the *i*-VES harness terminal into the rear of the DVD player (plug the *i*-VES harness terminal into the yellow label position).

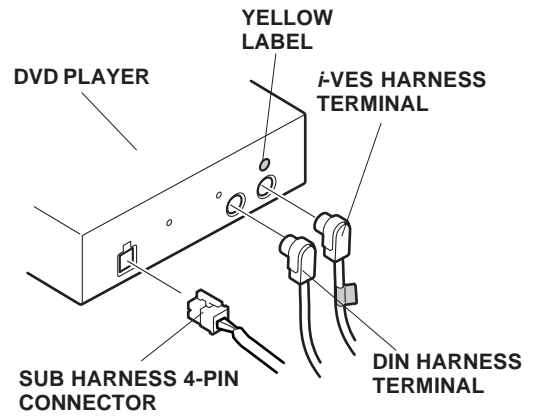

72. Install the DVD player to the brackets using four 6 mm flange nuts.

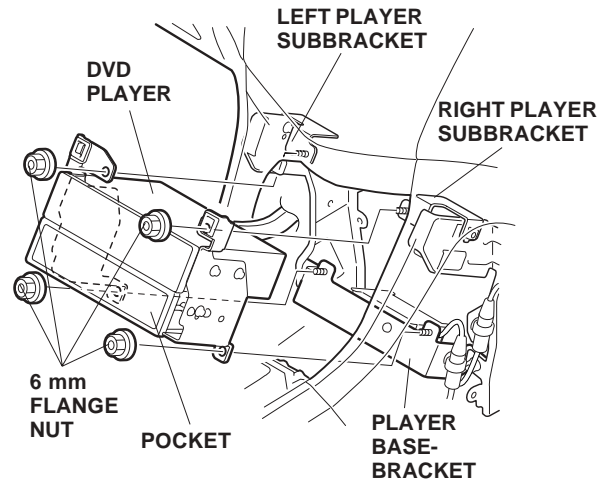

73. Measure and cut the EPT sealer as shown.

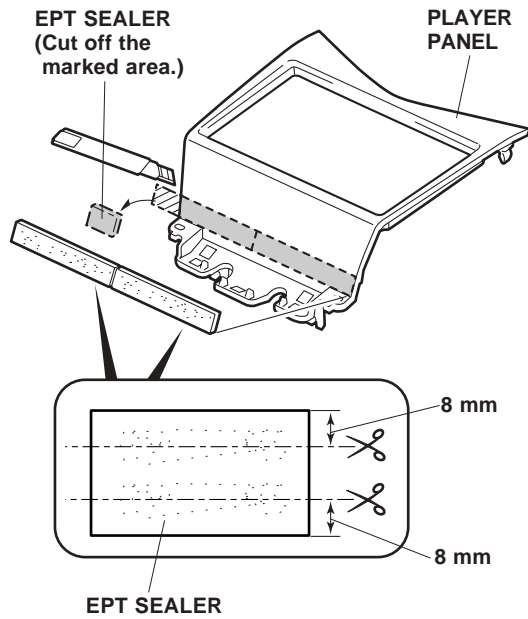

74. Clean the player panel with isopropyl alcohol where the EPT sealers will be attached. Attach the player panel with the EPT sealer, and cut off the marked area from the player panel.

75. Attach the two grommet screws to the player panel.

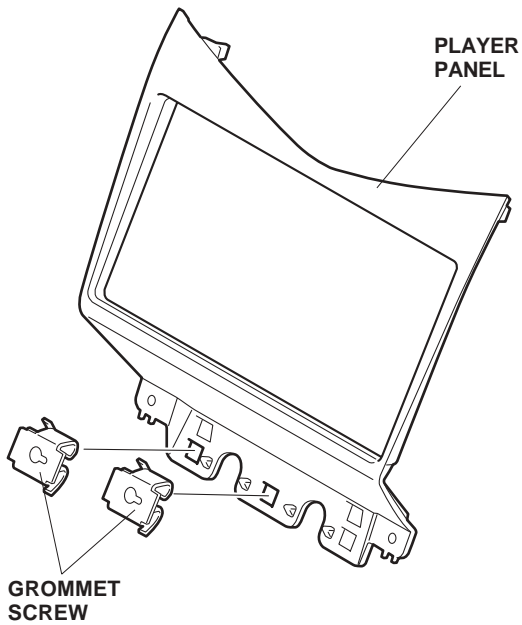

76. Insert the player panel clips into latches, and attach the player panel to the instrument panel with the two self-tapping screws removed in step 13. Remove the masking tape.

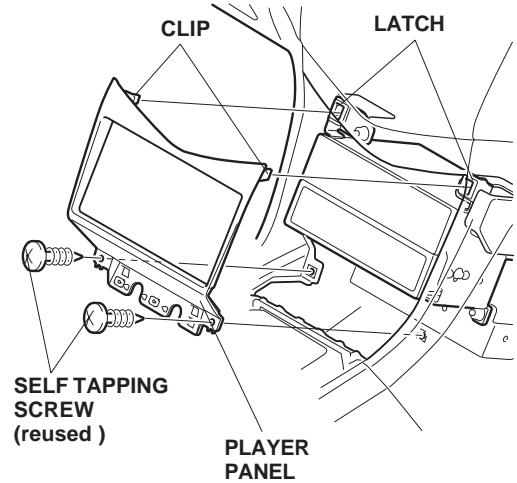

77. Check that all wire harnesses are routed properly and all connectors are plugged in.
78. Reconnect the negative cable to the battery.
79. Enter the customer's radio anti-theft code, and reset the radio station presets.
80. Set the clock.
81. Check the operation of the in-vehicle entertainment system according to the its Owner's Manual.
82. Put the in-vehicle entertainment system Owner's Manual in the glove box.
83. Reinstall all removed parts.
 - Tighten the seat belt anchor bolts to the specified torque: 29.4 to 34.3 N·m (3.0 to 3.5 kgf·m, 21 to 25 lbf·ft)

NOTE: Whenever the battery is disconnected, the driver's window AUTO function is disabled.

84. Start the engine. Push down fully on the driver's window switch until the window is fully open.
85. Pull up fully on the driver's window switch to close the window completely, then hold the switch for 2 seconds.
86. Test the window AUTO function.