



INSTALLATION INSTRUCTIONS

Accessory	Application	Publications No.
XM RADIO SYSTEM	ACCORD 4 DOOR	All 30280
		Issue Date SEP 2005

The XM Radio will not fit in a vehicle equipped with a rear entertainment system.

PARTS LIST

**XM Radio Attachment Kit (sold separately):
P/N 08B15-SDA-100**

DIN cable



XM radio harness

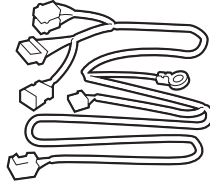

Front unit bracket

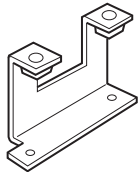

Rear unit bracket

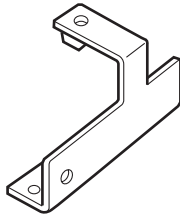

Bracket A

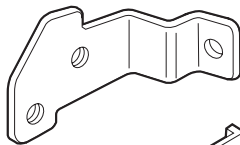

Bracket B

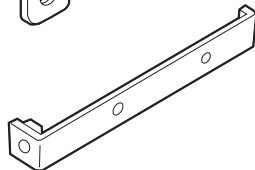

Bracket C

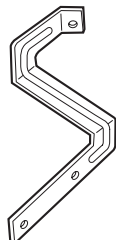

Template

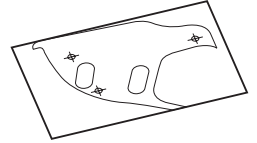

Double-sided adhesive tape

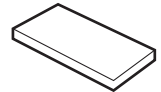

Display module pocket

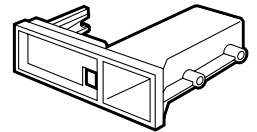

Clip nut



3 Self-tapping screws



Fastener

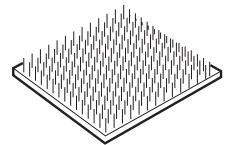

Ground bolt (gold)



6 Washer-screws, 4 x 8 mm



6 Washer-bolts, 6 x 12 mm

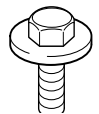

4 Flange nuts, 4 mm



29 Wire ties

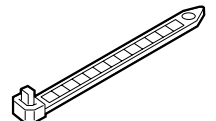

Connector clip



8 Wire tie with clips (two not used)

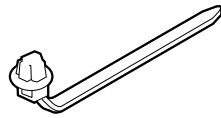

5 Cushion tapes

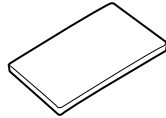

5 EPT sealers

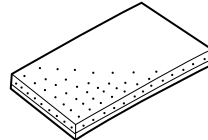

Fuse label

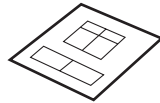

Mini fuse, 5A

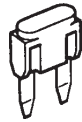

**Antenna Kit (sold separately):
P/N 08A15-1E1-100**

Antenna cable

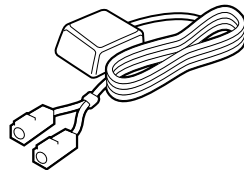

**Base Kit (sold separately):
P/N 08A15-1E1-000**

Display Module

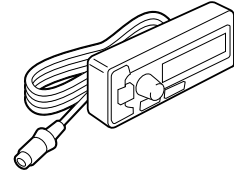

FM modulator unit

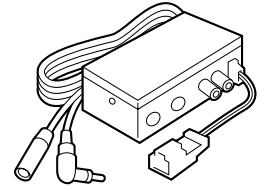

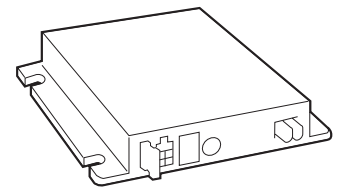

Receiver unit

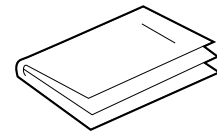

Owner's Manual

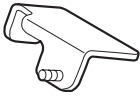
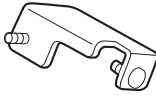
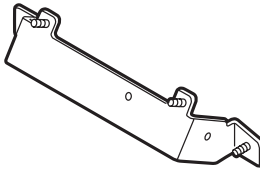
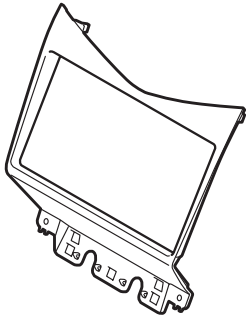
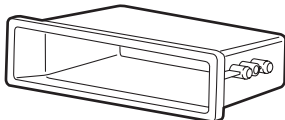

Audio Attachment Kit (sold separately):
P/N 08B06-SDA-100
 (Not required if already equipped with a player.)

- Left player bracket 
- Right player bracket 
- Left player subbracket 
- Right player subbracket 
- Player base-bracket 
- Player panel 
- Pocket 

BUS cable
 (Used on vehicles without a navigation system)

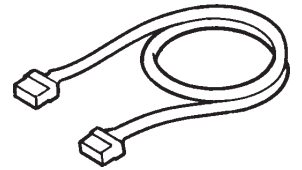

2 Latches



8 Flange nuts, 6 mm



2 Grommet screws



2 Wire ties

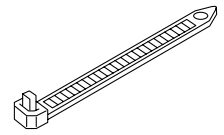

3 EPT sealers

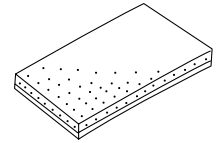

2 Self-tapping screws, 4 x 12 mm



Audio Subharness (sold separately):
P/N 08A31-0E1-010

If the vehicle is equipped with a navigation system and already has an installed cassette/MP3/CD player, use this audio subharness cable. Do not use this cable when the vehicle is to be equipped with the XM radio only.

Audio subharness cable
 (Used on vehicles with a navigation system)

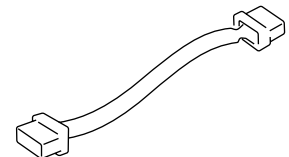

TOOL AND SUPPLIES REQUIRED

Phillips screwdriver
Stubby phillips screwdriver
Flat-tip screwdriver
Isopropyl alcohol
Shop towel
Tape measure
Utility knife
Hook tool
Ratchet wrench
8 mm and 10 mm Sockets
Felt-tip pen
Scissors
Push pin
Vinyl tape
Drill
3 mm and 10 mm Drill bits
Touch-up paint
Eye protection (face shield, safety goggles, etc.)
Masking tape

Illustration of the XM Radio System Installed in the Vehicle

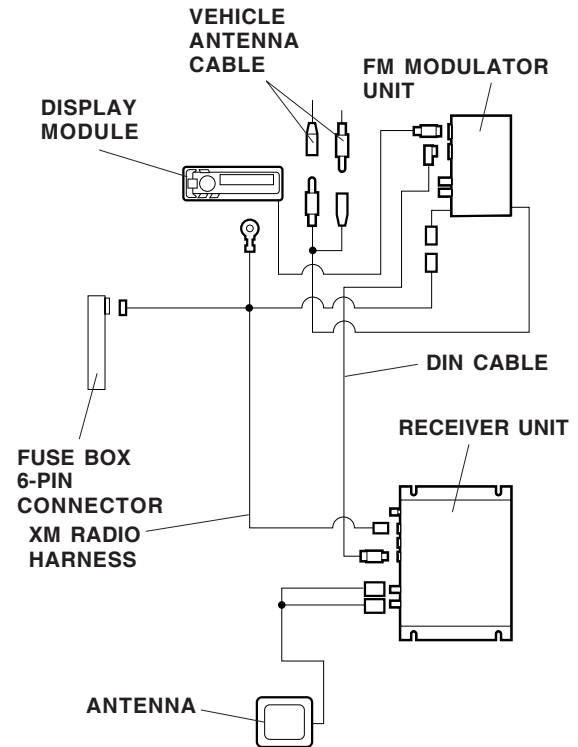
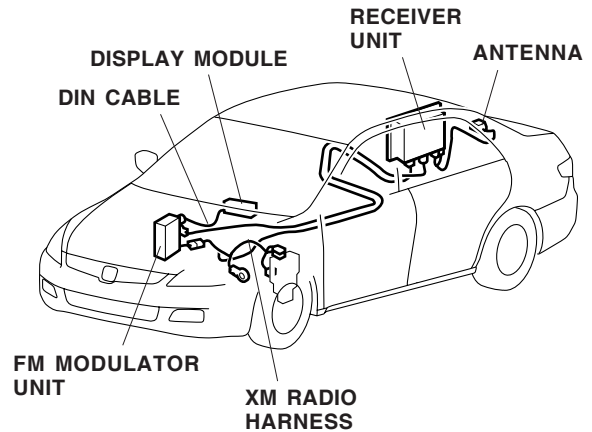

INSTALLATION

Customer Information: The information in this installation instruction is intended for use only by skilled technicians who have the proper tools, equipment, and training to correctly and safely add equipment to your vehicle. These procedures should not be attempted by “do-it-yourselfers.”

1. Make sure you have the anti-theft code for the radio, then write down the radio station presets.
2. Disconnect the negative cable from the battery.

- Remove the trim ring.

M/T Vehicle:

- Squeeze the plastic clip, and pull down on the shift boot. Remove the shift knob by turning it counterclockwise.

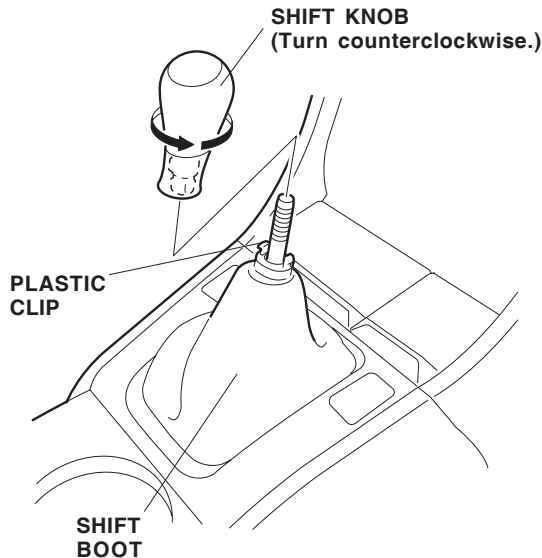

- Gently pry up on the trim ring to release the six clips.
- Unplug the two seat heater connectors (if equipped), and remove the trim ring.

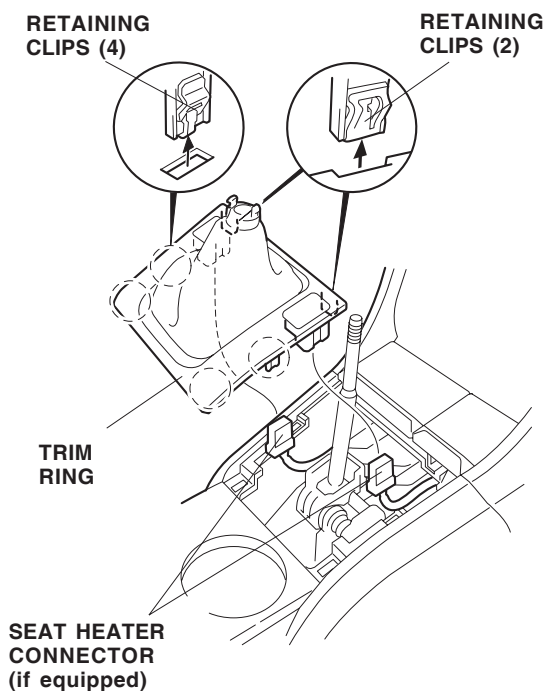

A/T Vehicle:

- Gently pry up on the trim ring to release the six clips.
- Unplug the two seat heater connectors (if equipped), and remove the trim ring.

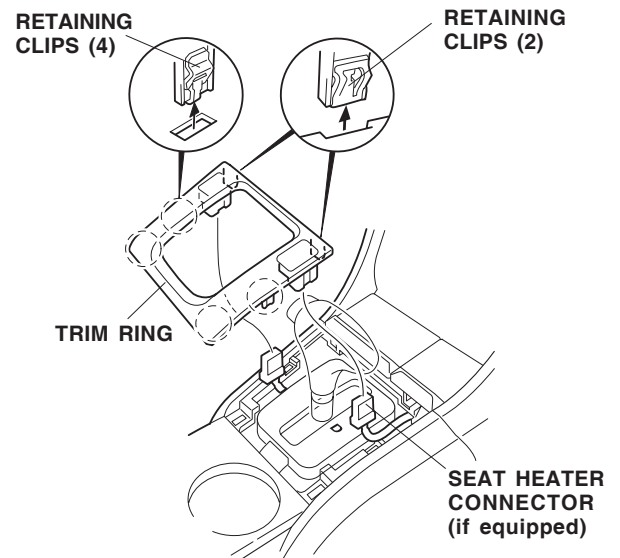

- Remove the center holder.
 - Open the lid, and remove the coin pocket.
 - Remove the two self-tapping screws.
 - Gently pull out the dashboard center holder to release the two retaining clips, unplug the vehicle connector, and remove the center holder.

With Coin Pocket:

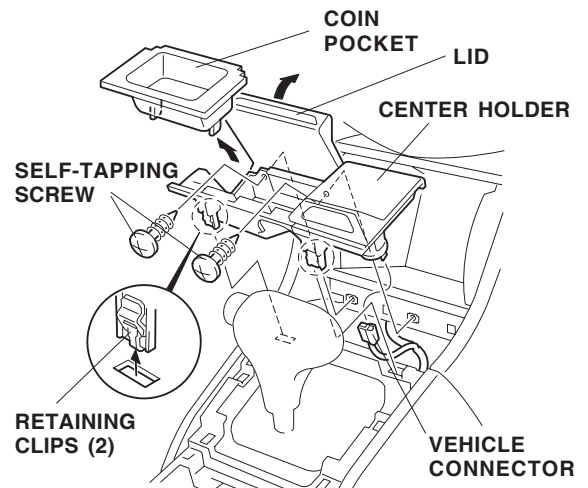

With Optional Ashtray:

- Open the lid, and remove the ashtray.
- Remove the two self-tapping screws.
- Gently pull out on the two retaining clips, unplug the cigarette lighter harness connector, vehicle connector, illumination bulb, and remove the center holder.

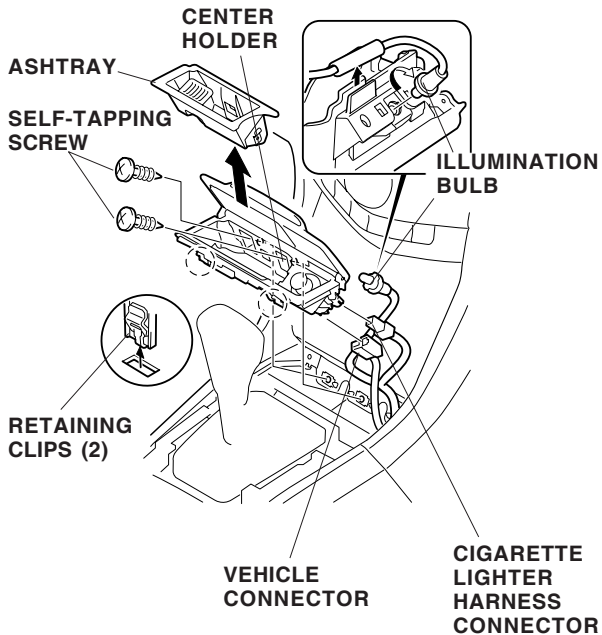

If the vehicle is equipped with a Cassette/MP3/CD Player, go to step 13; otherwise, go to step 5.

5. Remove the pocket:
- Apply masking tape to the edge of the center panel.
 - Remove the two self-tapping screws.
 - Push in on the bottom of the lid, then pull out on the top by inserting the end of a hook tool between the pocket and center panel. Pull the pocket toward you to release the two retaining clips.
 - Set the pocket aside; it will not be reused.

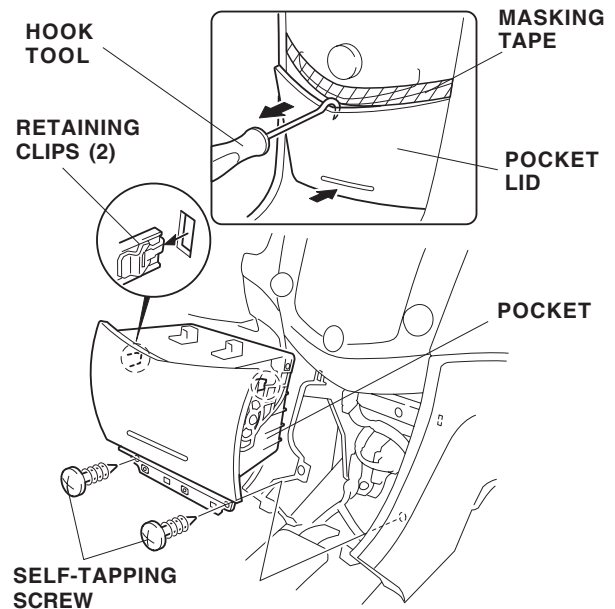

6. Remove the right and left inner covers (one hook and one clip for each cover). Set the inner covers aside; they will not be reused.

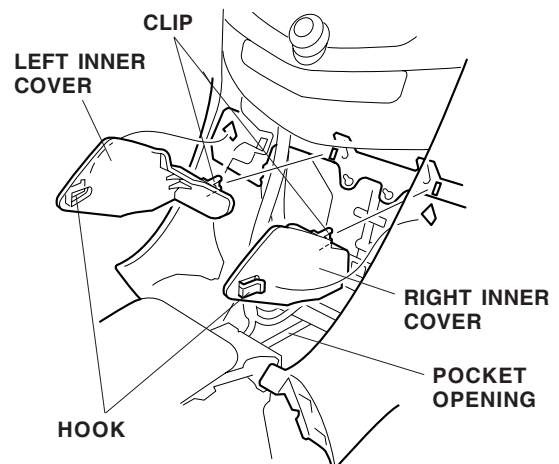

- Remove the vehicle harness clip from the vehicle frame, and move the clip out of the way.

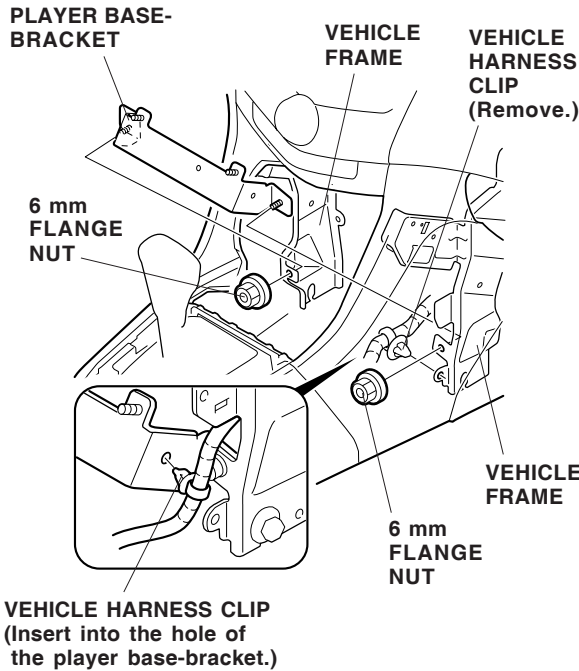

- Insert the studs from the player base-bracket into the holes in the vehicle frame from the back. Install the two 6 mm flange nuts while holding the bracket firmly against the vehicle frame. Insert the vehicle harness clip (removed in step 7) into the hole in the player base-bracket.
- Insert the studs of the left and right player subbrackets into the holes in the vehicle frame, and install one 6 mm flange nut on the end of each stud while pushing each subbracket upward.

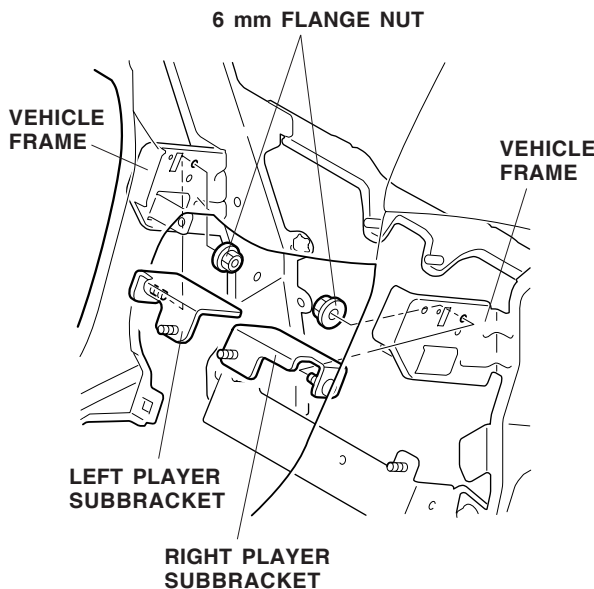

- Get the pocket from the audio attachment kit. Using a utility knife, cut the two lugs off of the pocket.

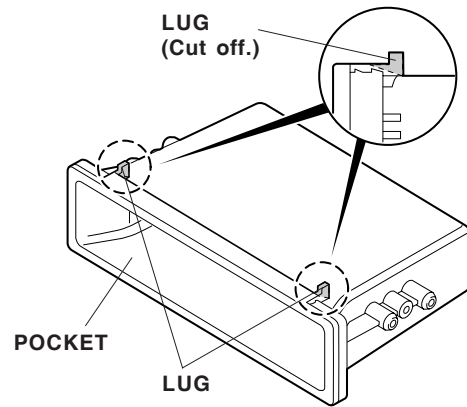

- Install one latch onto the left and right player brackets. Slide the clip nut onto the display module pocket flange.

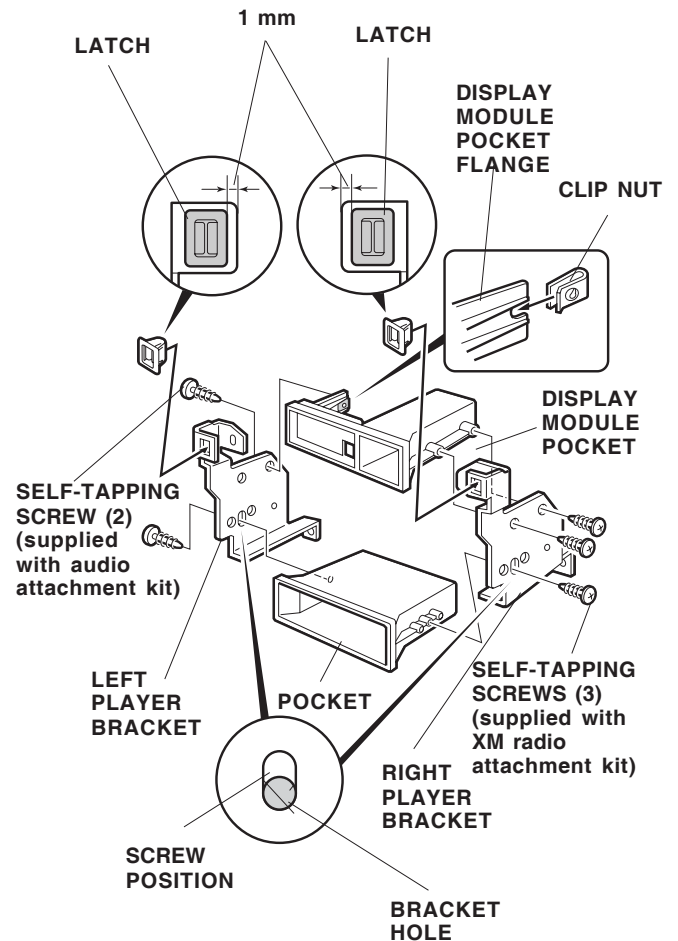

- Set the display module pocket on the pocket with the cut out facing up. Position the left and right player brackets on the display module pocket and pocket, and install five self-tapping screws.

If the vehicle is not equipped with a Cassette/MP3/CD Player, go to step 18; otherwise, go to step 13.

- Remove the player panel by removing the two self-tapping screws and two clips.

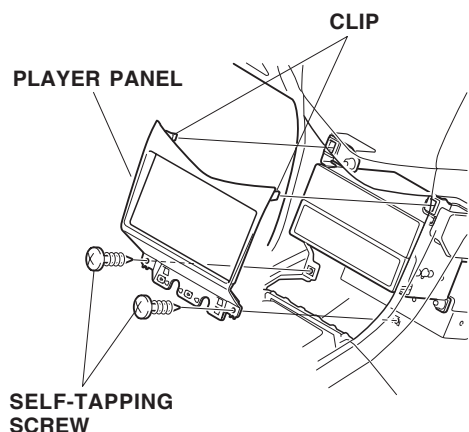

- Remove the player/pocket assembly. Unscrew the four flange nuts, and pull the assembly out toward you. Unplug the audio subharness cable connector.

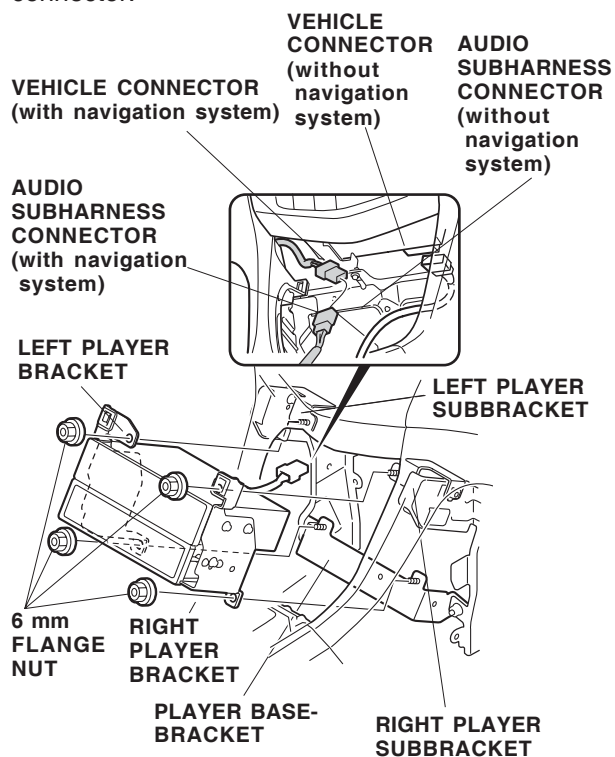

- Remove the left and right audio brackets (two washer-screws and one self-tapping screw for each bracket). Separate the player and pocket. Set the pocket aside; it will not be reused.

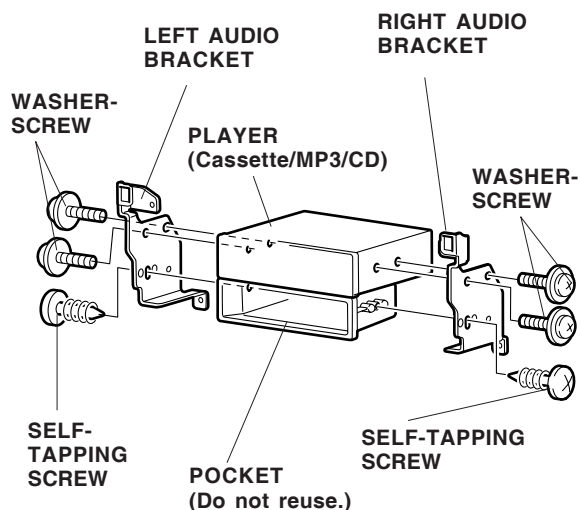

- Slide the clip nut (supplied) onto the display module flange.

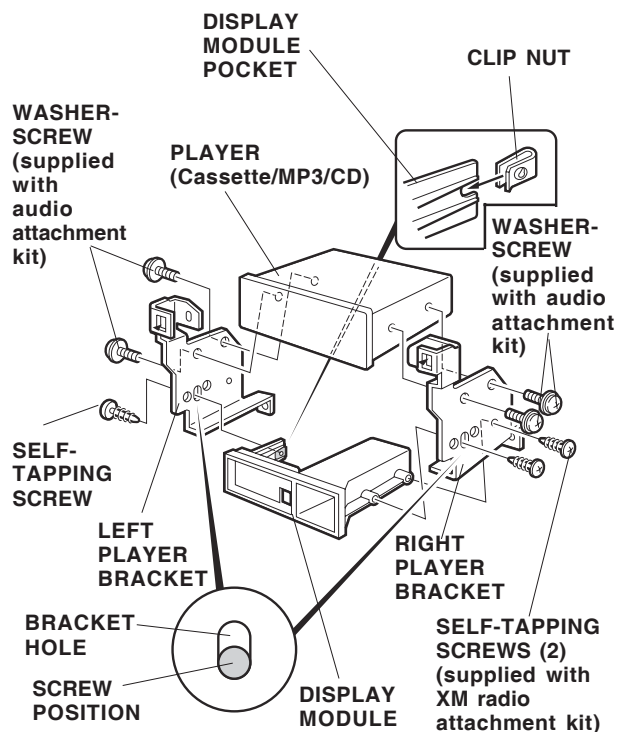

- Set the player on the display module pocket. Position the left and right player brackets on the display module pocket and player, and reinstall the four washer-screws. Install the three self-tapping screws to secure the display module pocket.

Installing the Display Module

18. Attach the display module to the display module pocket:
 - Using isopropyl alcohol on a shop towel, clean the back of the display module where the adhesive backing will attach.
 - Remove the backing from one side of the double-sided adhesive tape, and attach it to the display module.
 - Remove the remaining backing from the double-sided adhesive tape. Route the display module cable through the hole of the display module pocket, and attach the display module to the pocket.

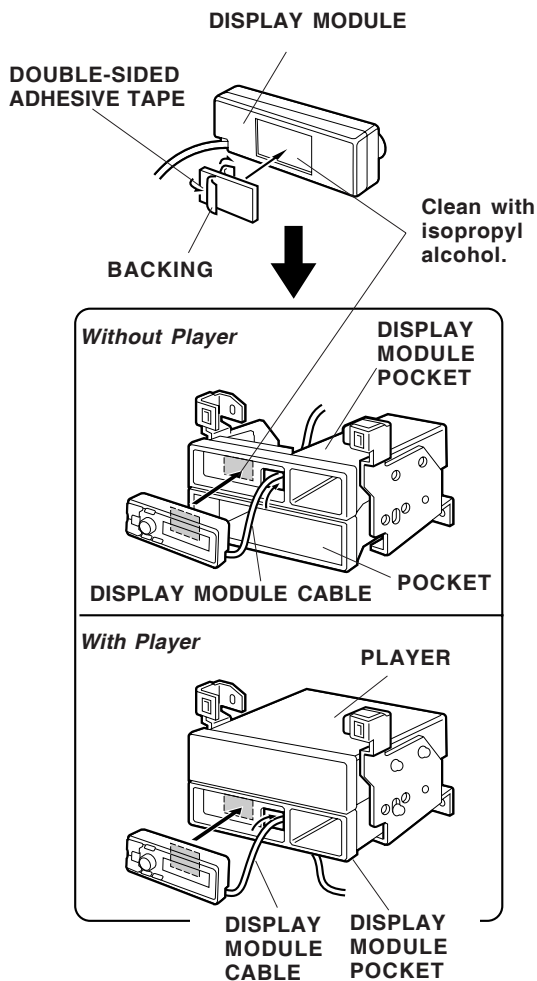

Routing the XM Radio Harness

19. Remove the beverage holder (pull up to release the six retaining clips).

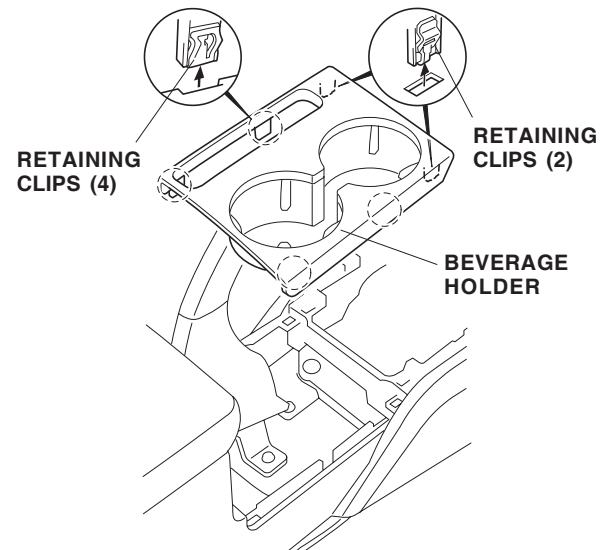

20. Remove the rear console.
 - Open the lid, and remove the rear console mat from inside the rear console.
 - Remove the two screws and four self-tapping screws, and unplug the connector and harness clip (if equipped).
 - If equipped with a console-mounted CD changer, remove the changer from the rear console.

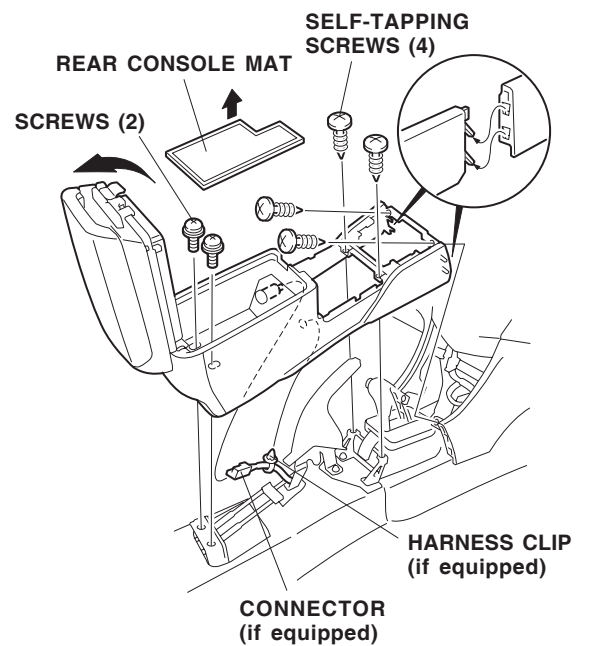

21. Remove the driver's dashboard lower cover:

- Remove the self-tapping screw.
- First release the four clips on the left side by pulling out on the driver's dashboard lower cover.
- After releasing the four clips, insert a flat-tip screwdriver behind the clip at the dashboard frame. Gently twist the screwdriver to release the clip.
- Release the two clips on the right side. Unplug the vehicle connector, and then remove the lower cover.

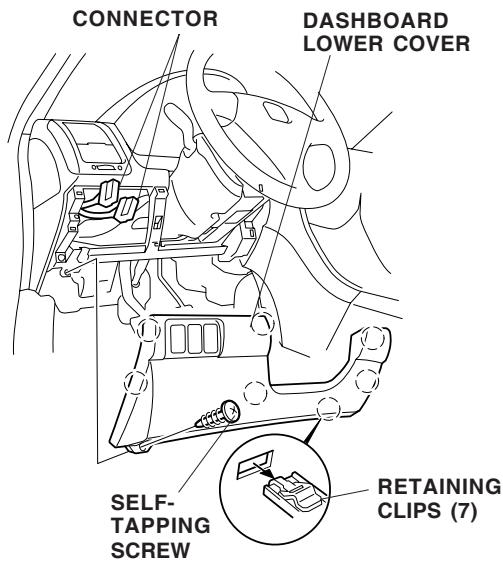

22. If equipped, remove the driver's dashboard under cover (release the three retaining clips, one pin, and one holder).

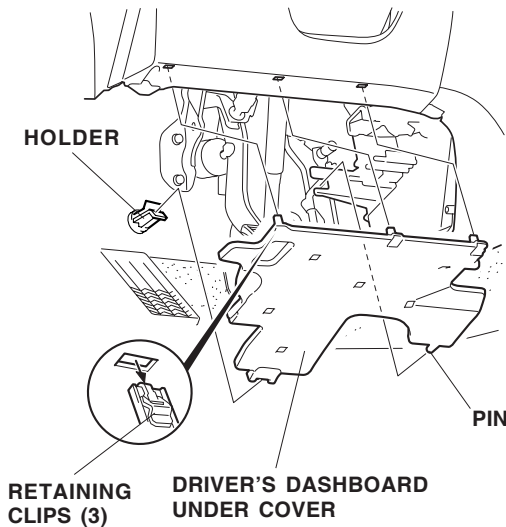

23. Remove the self-tapping screw and the clip that secure the left front console cover. Take care not to damage the clip, and remove the console cover.

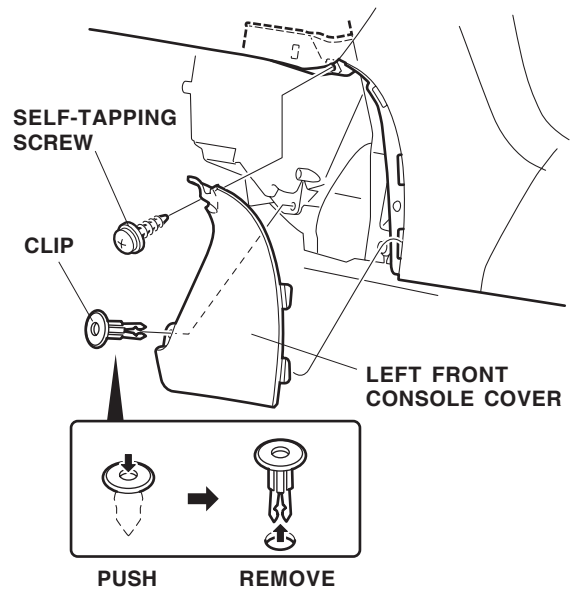

24. Remove the glove box by removing the two bolts, and then release the damper rod.

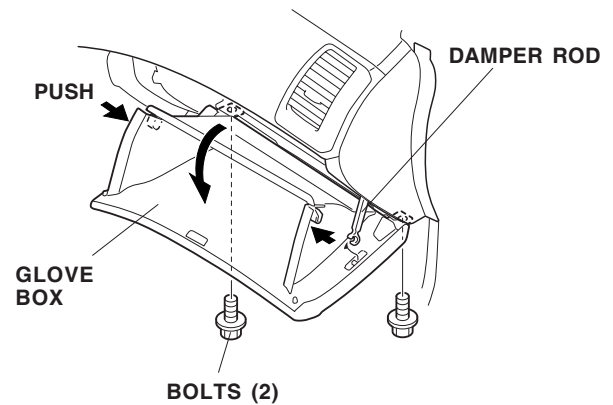

- On the driver's side of the vehicle, locate the 6-pin connector on the fuse box. Plug the XM radio harness 6-pin connector into the fuse box 6-pin connector.

NOTE: If the 6-pin connector is already being used by another accessory, locate the 6-pin connector taped to the XM radio harness. Remove the dummy connector from the harness, and plug the other accessory's harness 6-pin connector into the XM radio harness.

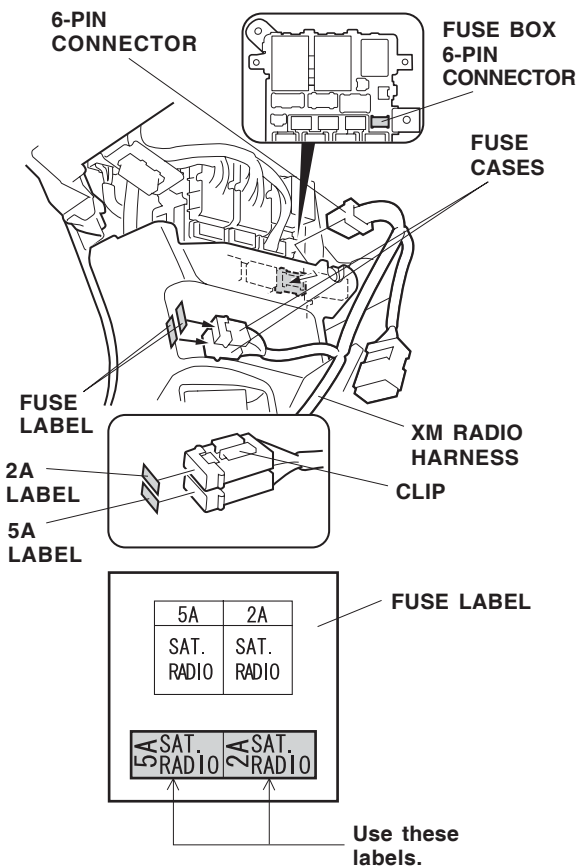
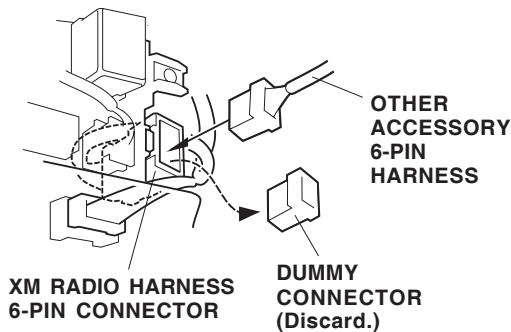

- Attach the fuse labels to the fuse cases on the XM radio harness.

- Install the XM radio harness fuse cases and the 6-pin dummy connector to the fuse box case.

Fuse case position

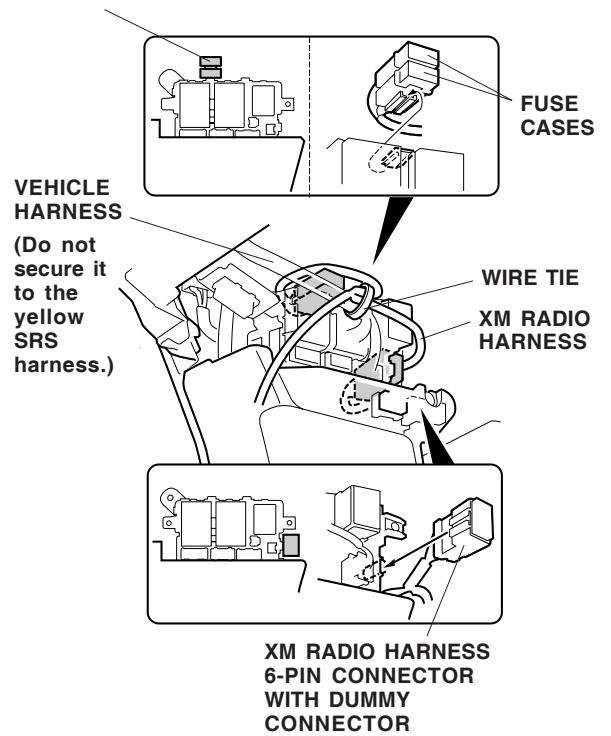

- Secure the XM radio harness to the vehicle harness with one wire tie. Do not secure it to the yellow SRS harness.
- Route the XM radio harness under the steering shaft and toward the center console.

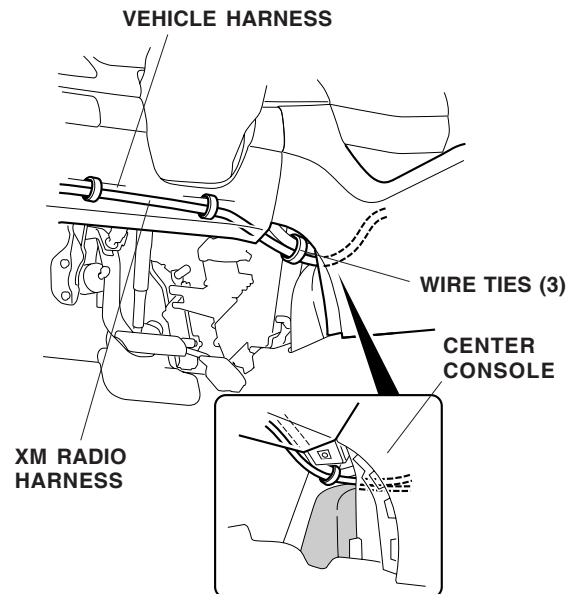

- Loosely attach the XM radio harness to the vehicle harness with three wire ties.

31. Inside the center console, locate the welded nut on the vehicle stay. Attach the XM radio harness ground terminal to the welded nut with the ground bolt supplied.

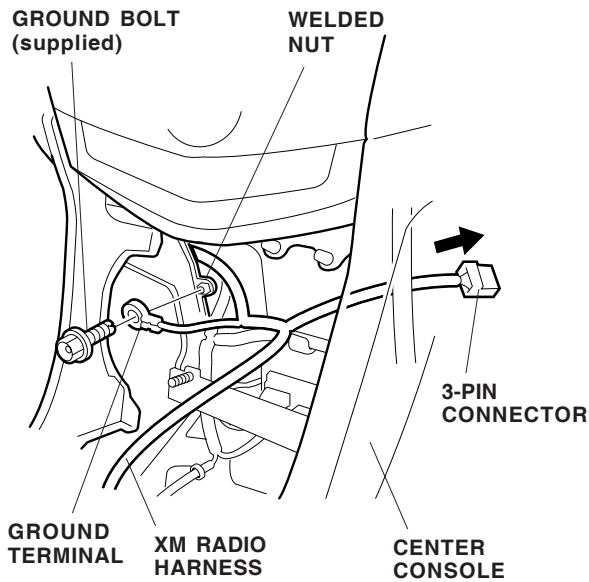

32. Route the XM radio harness 3-pin connector toward the glove box opening. Set the remaining XM radio harness aside; it will be routed later.

If the vehicle is not equipped with a Cassette/MP3/CD Player, go to step 34; otherwise, go to step 33.

33. Plug the audio subharness cable into the player.

Without Navigation System:

Cassette Player

Make loops in the audio subharness cable, and secure it with one wire tie, so that the distance between the ends of the cable connector is 200 mm. Plug the audio subharness cable connector into the cassette player connector.

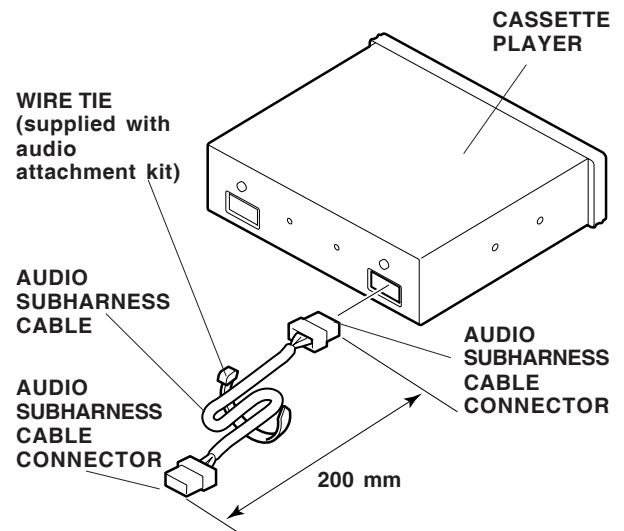

Multimedia Player

Make loops in the audio subharness cable, and secure it with one wire tie so that the distance between the ends of the cable connectors is 200 mm. Plug the audio subharness cable connector into the multimedia player connector.

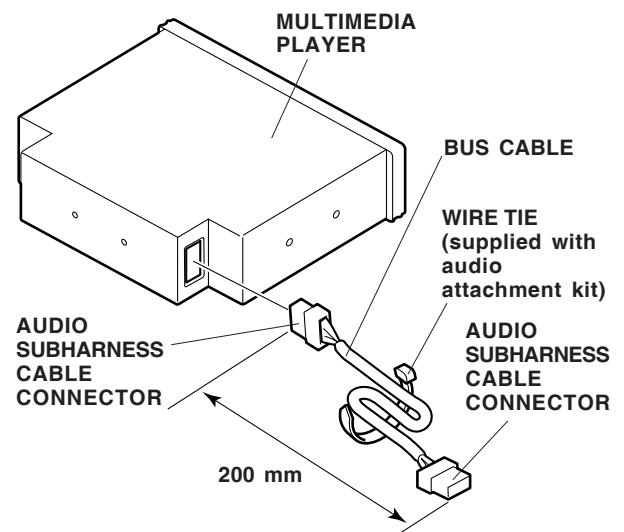

In-Dash CD Player

- Make loops in the audio subharness cable, and secure it with one wire tie so that the distance between the ends of the cable connector is 180 mm. Plug the audio subharness cable connector into the connector from the in-dash CD player.
- After connecting, secure the connectors to the rear of the in-dash player with one wire tie from the in-dash CD player kit.

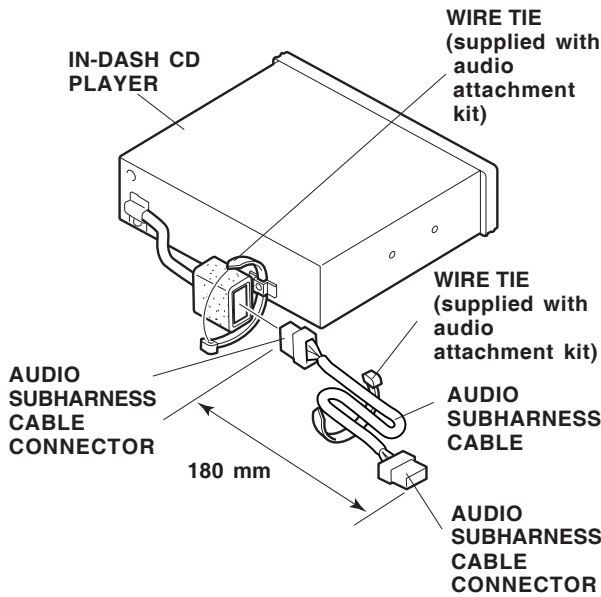

With Navigation System:

Remove the tape that secures the vehicle harness to the upper left pocket opening, and pull the harness out through the pocket opening.

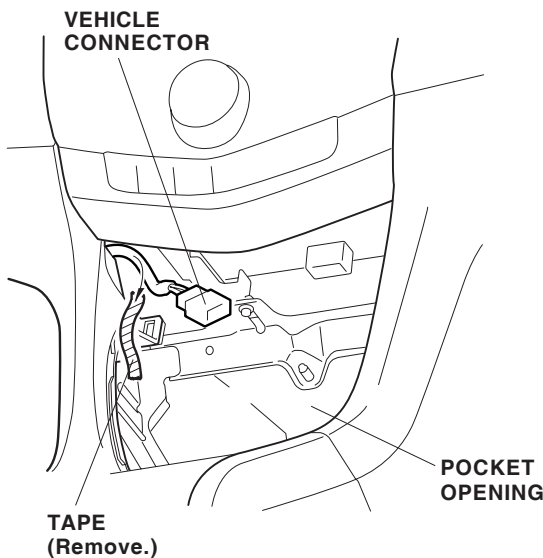

Cassette Player

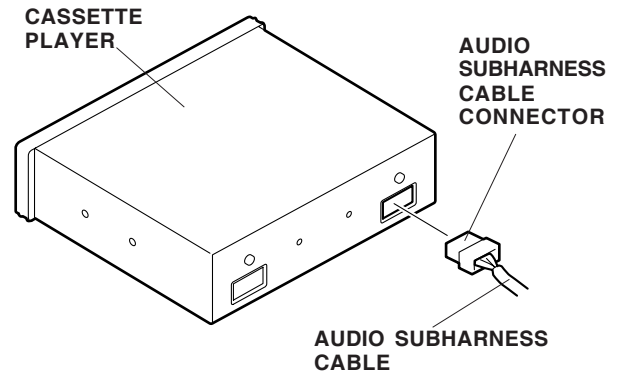

Multimedia Player

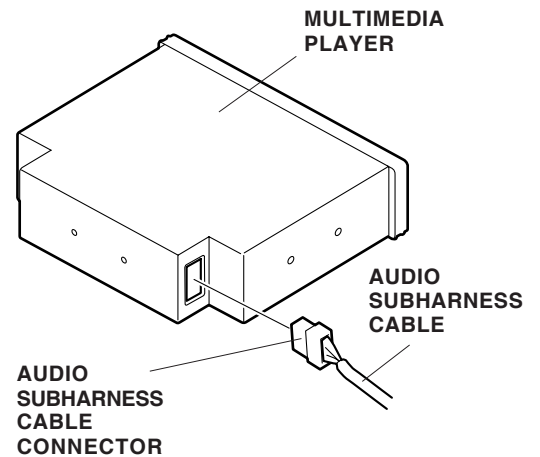

In-Dash CD Player

After connecting, secure the connectors to the rear of the in-dash CD player with one wire tie from the in-dash CD player kit.

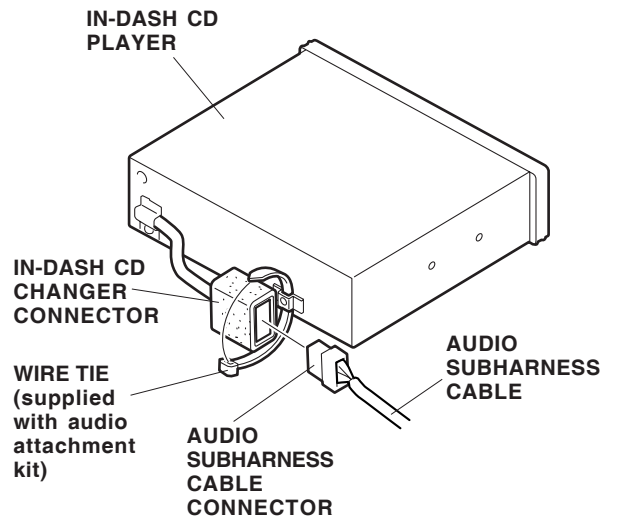

34. To protect the center panel, attach strips of masking tape to the center panel in the area shown.

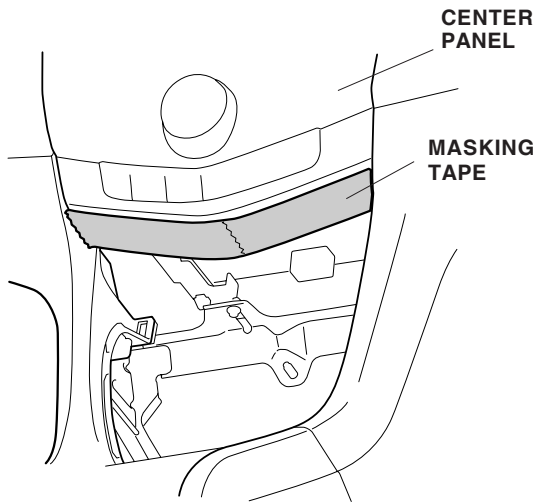

35. Get a DIN cable from the XM radio attachment kit. Route the 90° end of the DIN cable through the dashboard opening and toward the FM modulator unit.

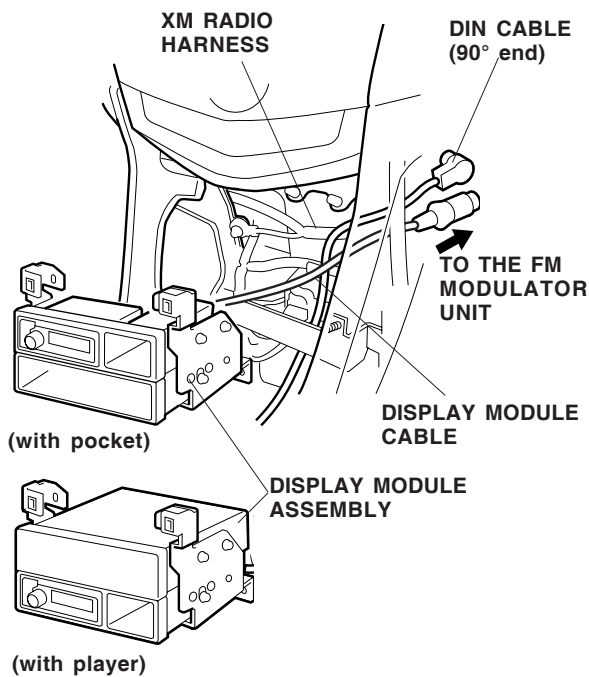

36. Place the display module assembly near the dashboard opening, and route the display module cable toward the FM modulator unit along the XM radio harness (3-pin connector) and the DIN cable.

37. Inside the glove box opening, locate the frame stay pipe. Align the holes in the frame stay pipe with the welded nuts in bracket A, and loosely attach bracket A to the pipe frame with two 6 x 12 mm washer-bolts.

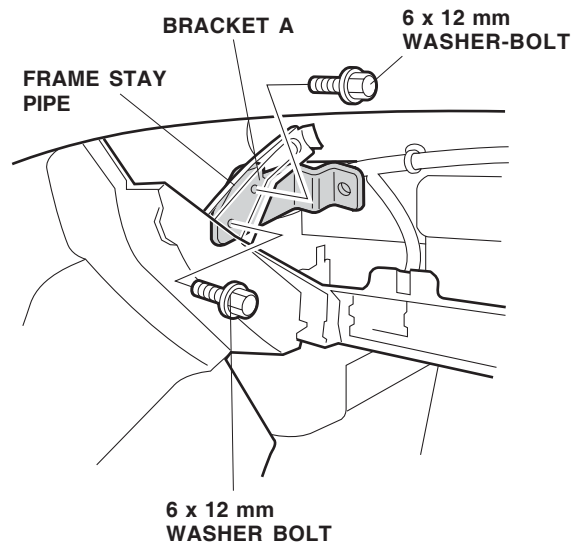

38. Attach the connector clip to the harness connector of the FM modulator unit. Attach bracket B to the FM modulator unit with one 4 x 8 mm washer-screw. Tighten the washer-screw securely.

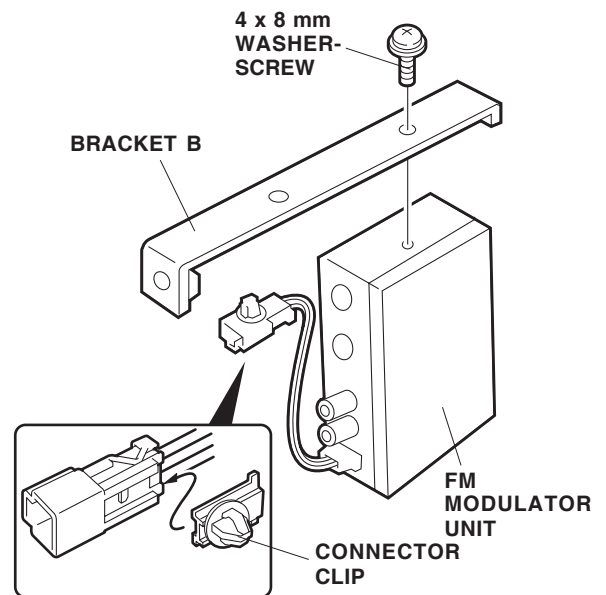

39. Plug the DIN cable and the display module cable into the FM modulator unit.

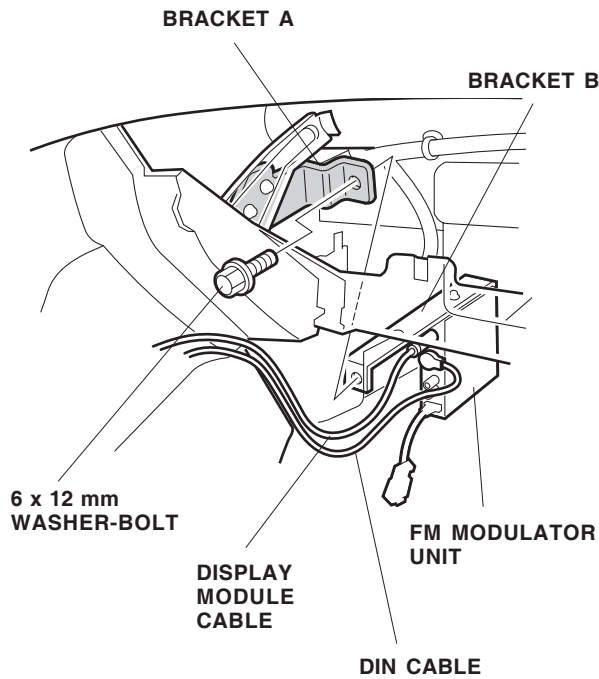

40. Attach bracket B with the FM modulator unit against bracket A, and install one additional 6 x 12 mm washer-bolt. Tighten all three 6 x 12 mm washer-bolts securely.
41. Route the antenna harnesses from the FM modulator unit rearward along the DIN cable toward the inside of the front console.

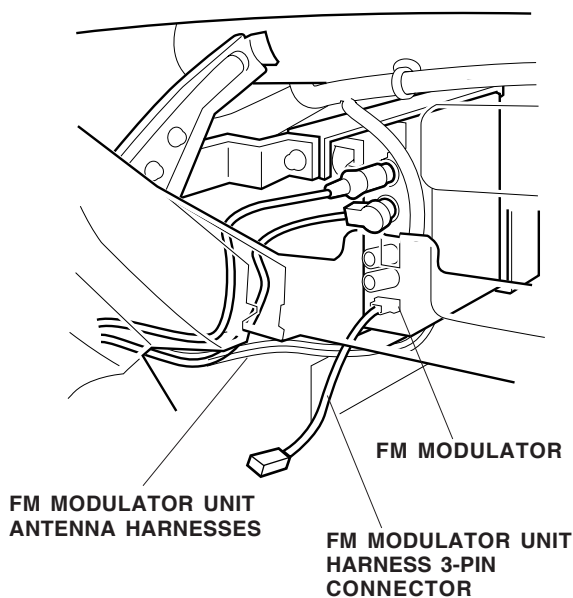

42. Below the glove box opening, remove the upper heater blower case mounting bolt.

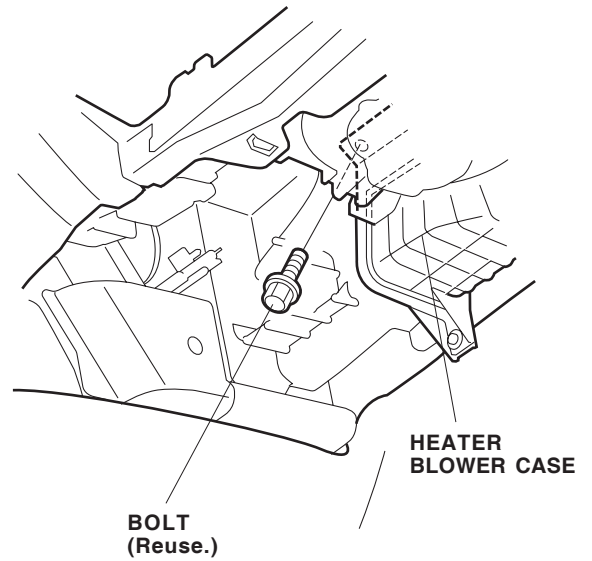

43. Attach bracket C to the bottom of the FM modulator unit with one 4 x 8 mm washer-screw, and attach the other end of bracket C to the upper heater blower using the bolt you removed in step 42.

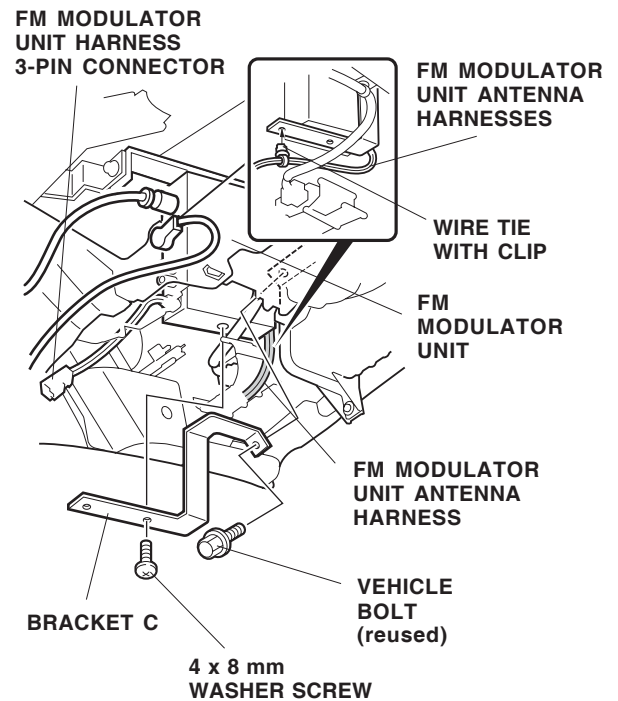

44. On the back of the FM modulator unit, attach one wire tie with clip to the antenna harnesses, and attach the wire tie with clip to the hole in bracket C.

45. Connect the XM radio harness 3-pin connector to the FM modulator unit harness 3-pin connector, then attach the 3-pin connector clip to the hole in bracket B.

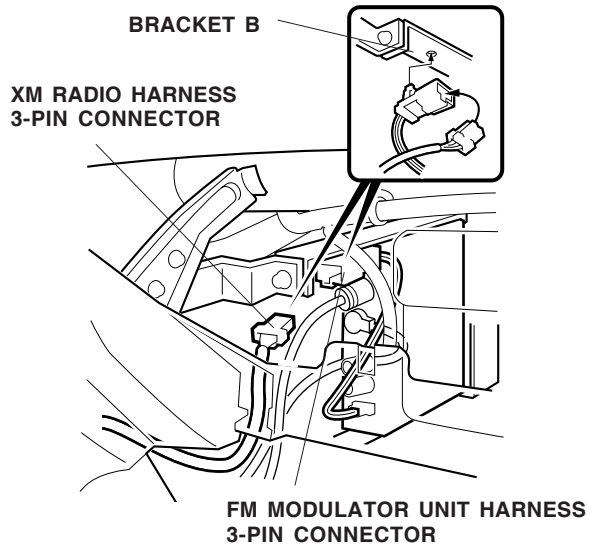

46. Unplug the vehicle antenna cable, and plug it into the FM modulator unit antenna cable. Plug the other FM module antenna jack into the vehicle antenna cable.

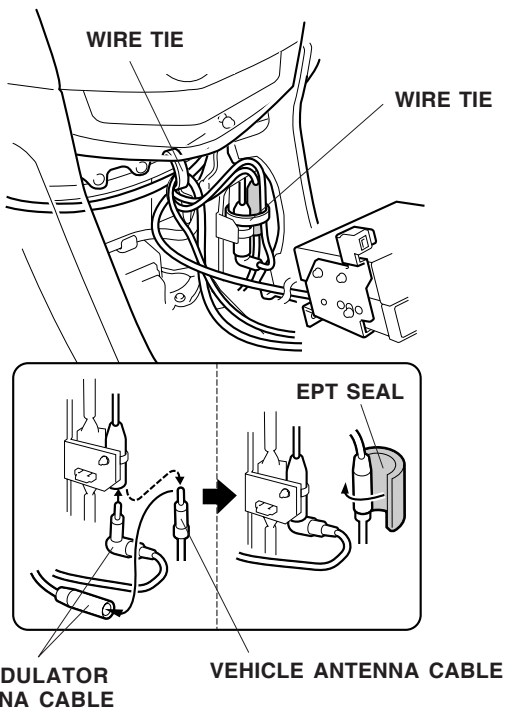

47. Wrap one EPT seal around the antenna jack, and secure the antenna jack to the vehicle antenna jack with one wire tie. Secure the DIN cable, the display module cable, and the antenna harness to the vehicle harness with one wire tie.

48. Secure the XM radio harness to the vehicle harness with one wire tie.

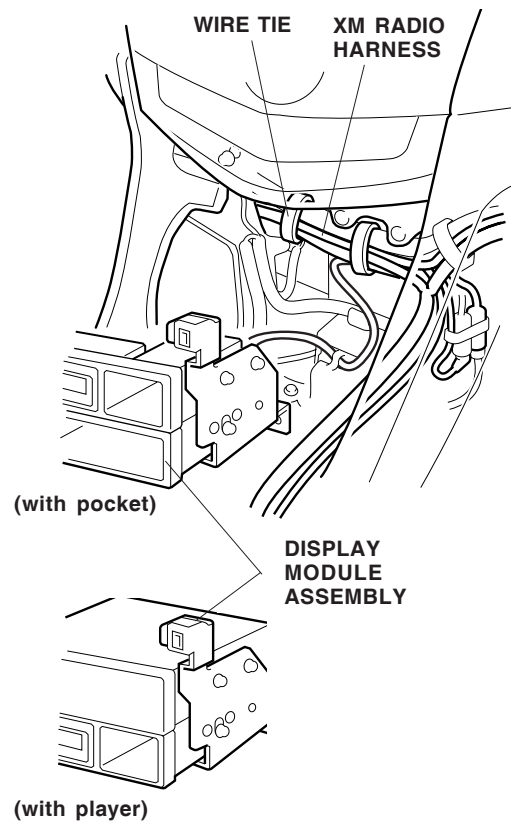

49. Bundle up the excess display module cable, and secure it with one wire tie.

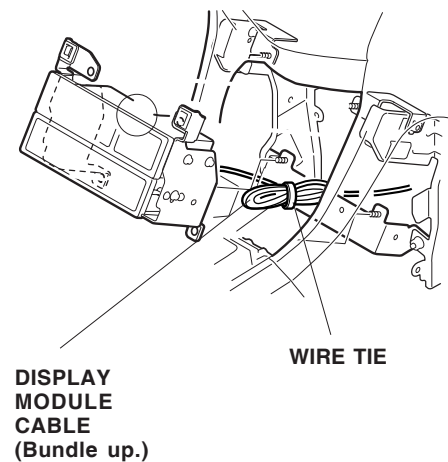

50. Plug the BUS cable connector into the vehicle connector. If the vehicle is equipped with a navigation system, plug the subharness connector into the vehicle connector, and wrap the connectors with one EPT sealer.

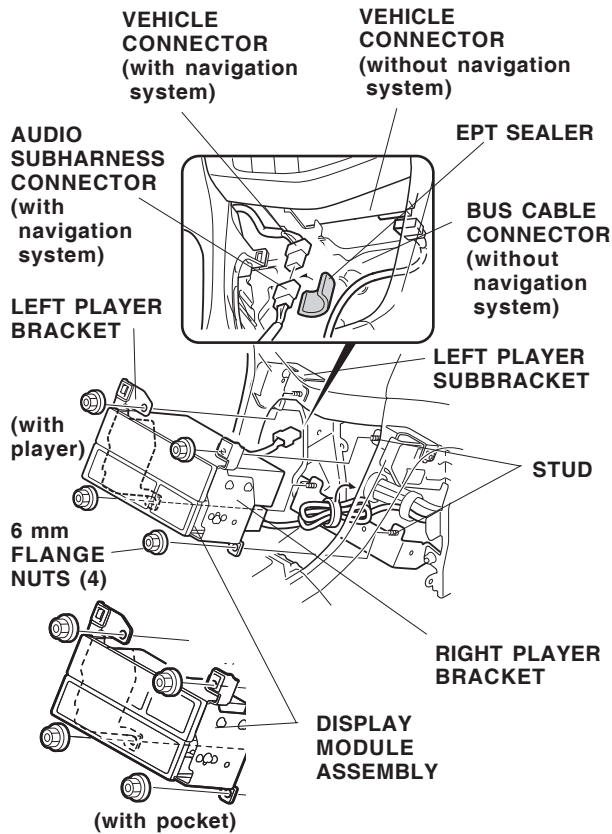

51. Install the display module assembly onto the studs of the left and right player subbrackets, and install the 6 mm flange nuts. Tighten the flange nuts securely.
52. If the vehicle is not equipped with a player, attach the two grommet screws to the player panel in the square holes as shown.

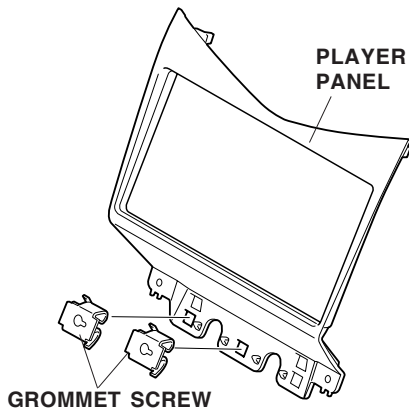

53. Get one EPT sealer. Measure the EPT sealer, and use scissors to cut it into three pieces.

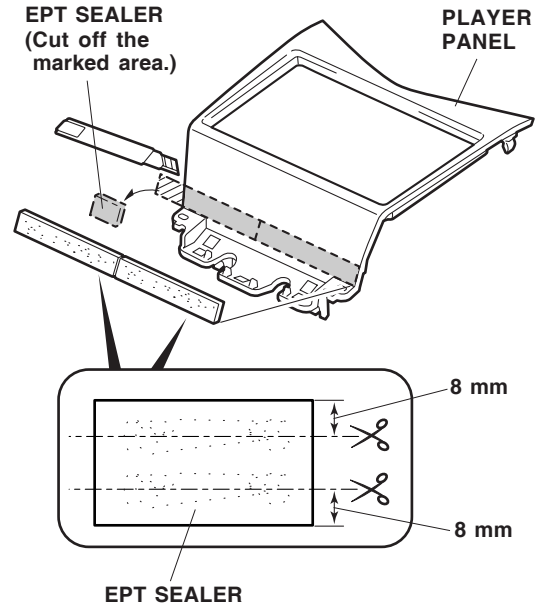

54. Using isopropyl alcohol on a shop towel, clean the player panel in the area shown. Attach the two cut pieces of the EPT sealer to the player panel, and cut off the excess.
55. Attach the player panel by inserting the clips into the latches, and install two self-tapping screws from the kit, or reinstall the two self-tapping screws you removed in step 13. Remove the masking tape.

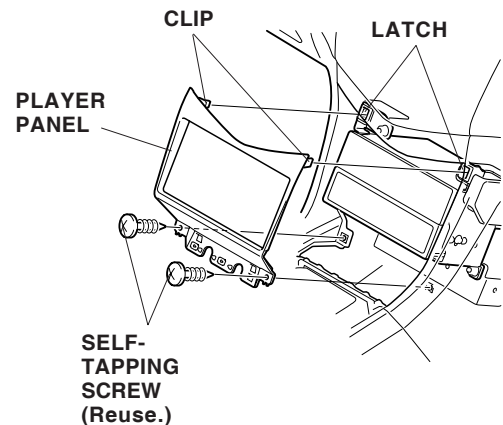

56. Inside the passengers' compartment, remove the rear seat cushion by removing the bolt and releasing the two locks (pull the hook out toward you).

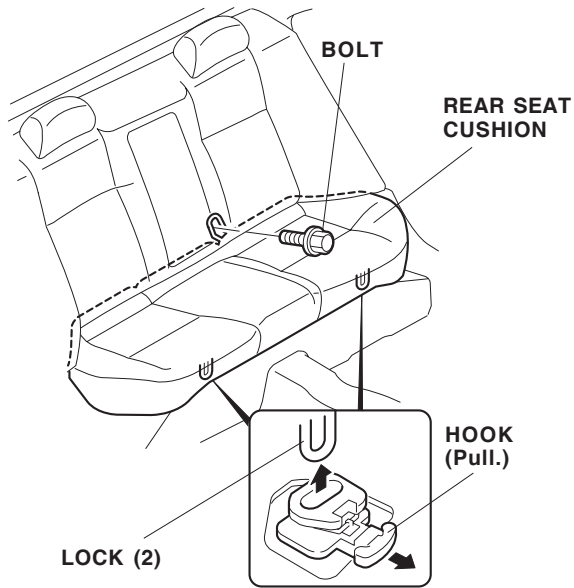

57. Remove the right side cushion by removing one bolt and one hook.

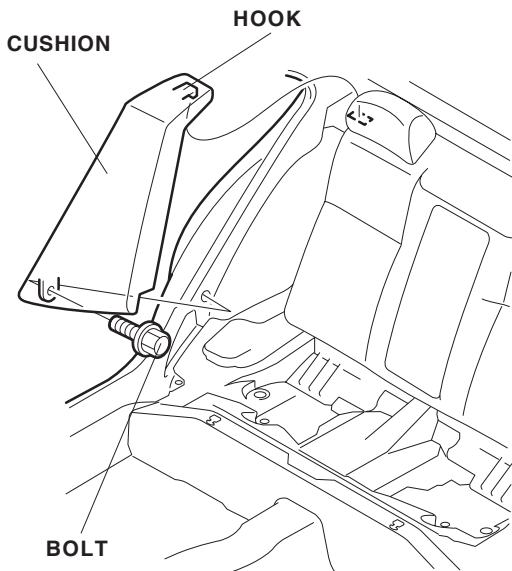

58. Inside the trunk, fold the rear seat-back forward by pulling the lever under the rear shelf.

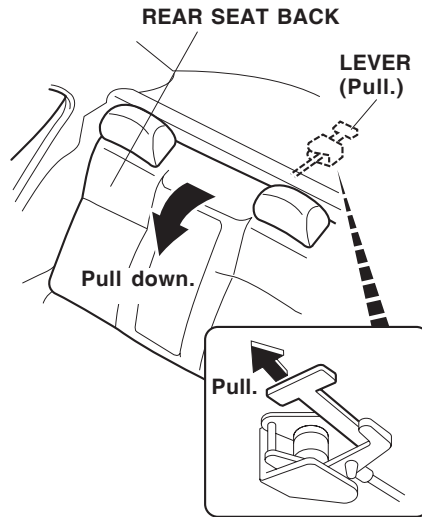

59. Remove the spare tire cover (one clip).

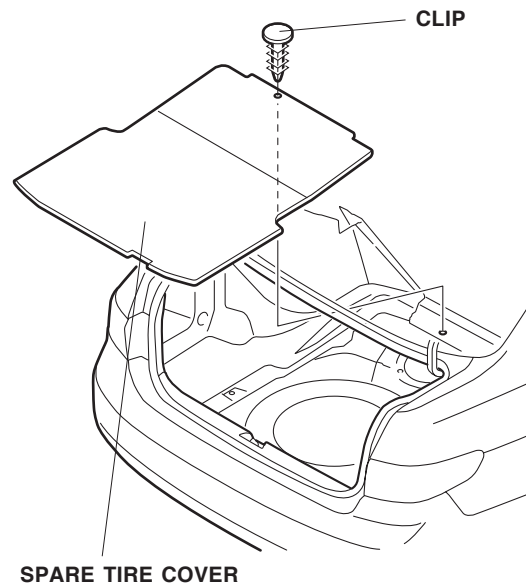

60. Remove the rear trim panel (four clips).

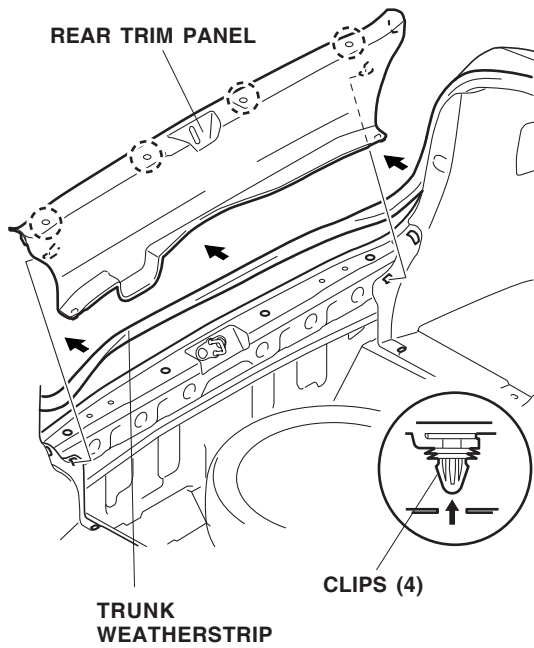

61. Remove the maintenance lid. Remove the jack cover and the jack.

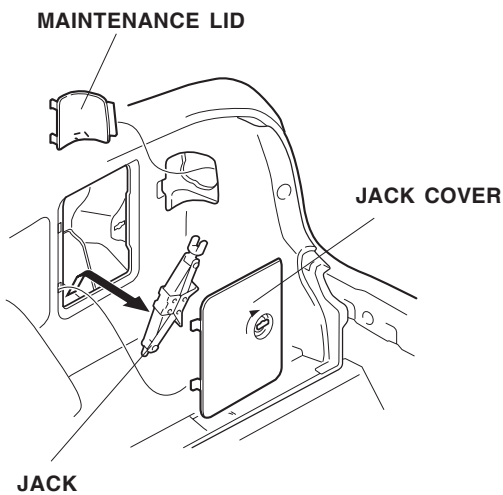

62. Remove the right trunk side trim panel liner:

- If equipped, remove the hook (one bolt, hook, and washer).
- Remove the four clips.
- Gently pull out on the trunk liner, and remove it.

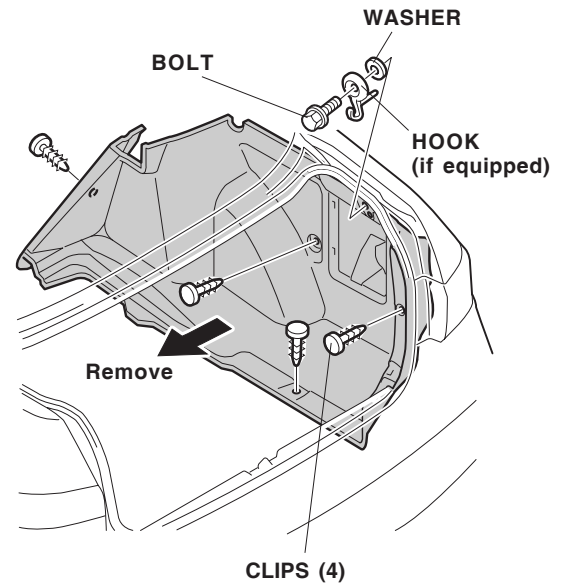

63. Inside the trunk area, unplug the high mount brake light harness connector. Inside the cabin, remove the high mount brake light from the rear shelf by releasing the four hooks, and pulling out on the brake light assembly. Take care not to damage the clips.

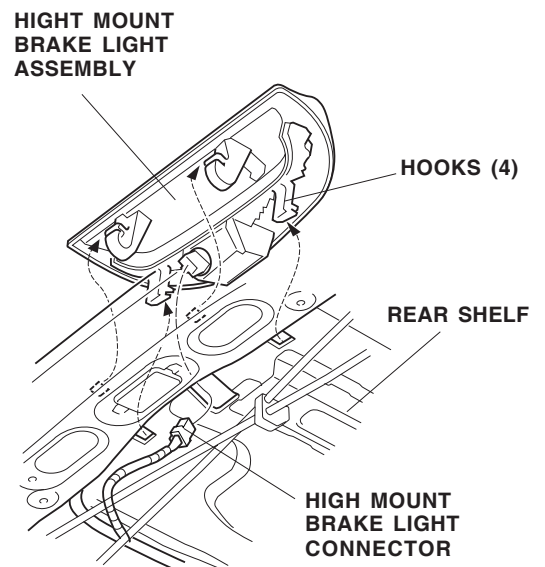

64. Route the XM radio harness and the DIN cable along the vehicle harness toward the parking brake lever, and under the floor carpet. Secure the harness and DIN cable to the vehicle harness with five wire ties in the areas shown.

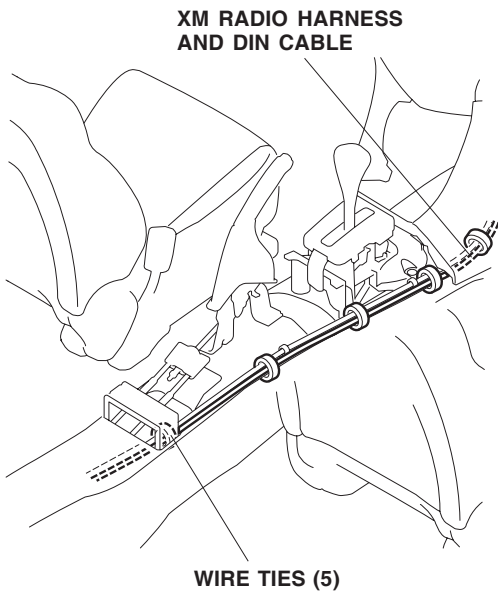

65. Raise the rear seat back. Pull the XM radio harness and DIN cable out from under the floor carpet and toward the passenger's side of the vehicle. Secure the harness and DIN cable to the vehicle harness with two wire ties. Attach the harness and DIN cable to the floor panel with four cushion tapes in the areas shown.

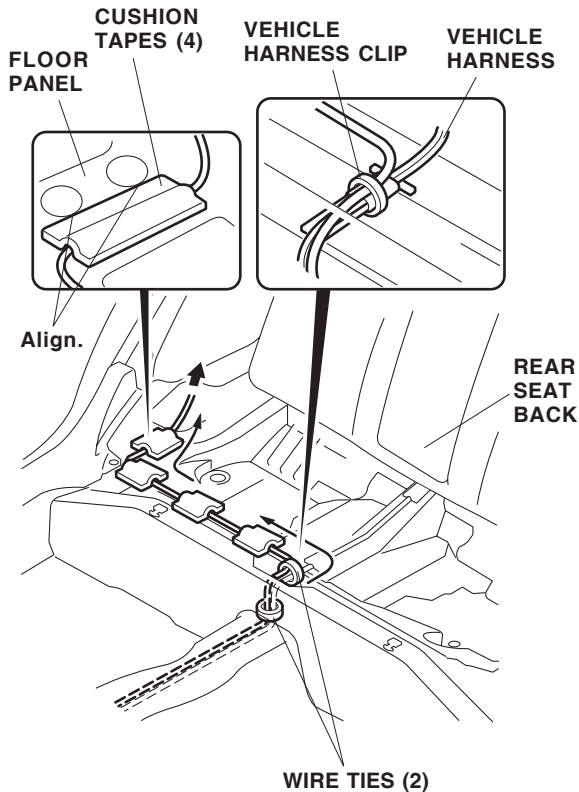

66. Remove the spacer from the rear quarter panel opening.

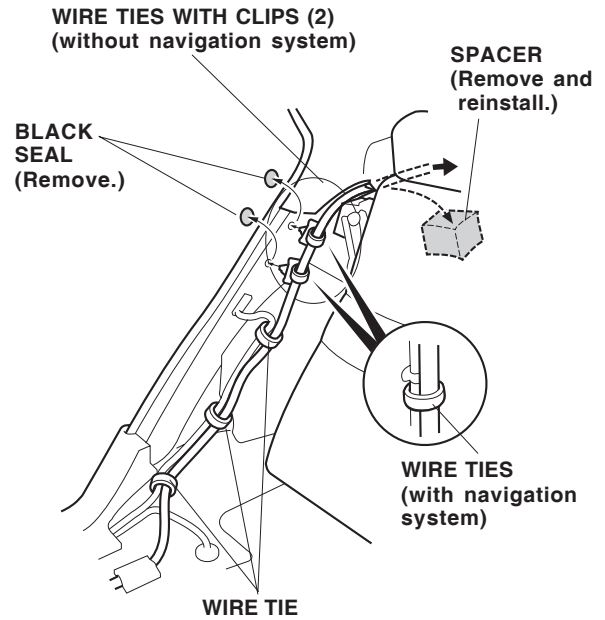

67. Route the XM radio harness and DIN cable up along the vehicle harness, and into the trunk.

Without Navigation System:

- Remove the two black seals from the body.
- Attach two wire ties with clips to the radio harness and DIN cable near the body holes.
- Insert the wire tie clips into the holes in the body, and secure the lower portion with three additional wire ties.
- Reinstall the spacer.

With Navigation System:

- Secure the XM radio harness and DIN cable to the vehicle harness with five wire ties in the areas shown.
- Reinstall the spacer.

Installing the Antenna

68. Get the antenna kit. Using isopropyl alcohol on a shop towel, clean the bottom of the antenna. Remove the adhesive backing from the fastener, and attach the fastener to the bottom of the antenna.

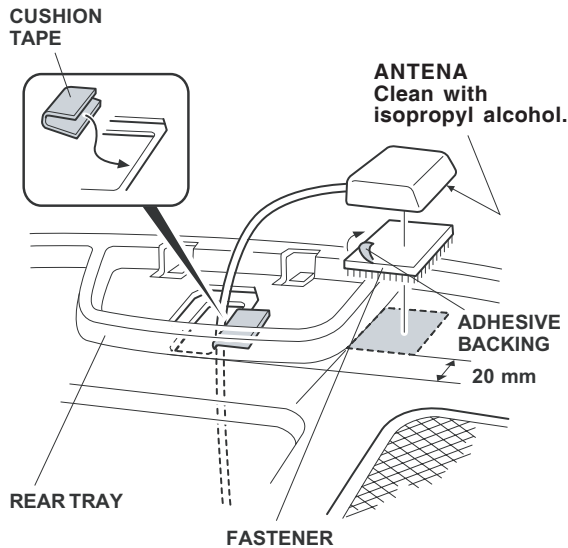

69. Route the antenna cable through the high mount brake light opening, and install the antenna onto the rear tray in the area shown. Attach one cushion tape to the edge of the high mount brake opening where the cable touches it.

70. Align the antenna cable on the rear tray with the brake light case, then using a felt-tip pen, mark the cable position on the edge of the case.

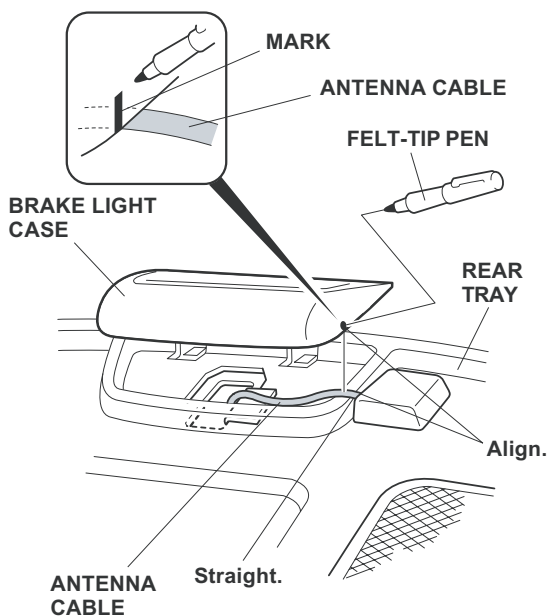

71. Measure the cutting area on the brake light case. Using a felt-tip pen, mark the area shown. Using a utility knife, cut out the brake light case in the area shown. Remove any burrs from the edges of the groove. Route the antenna cable through the groove in the high mount brake light case, and reinstall the brake light case.

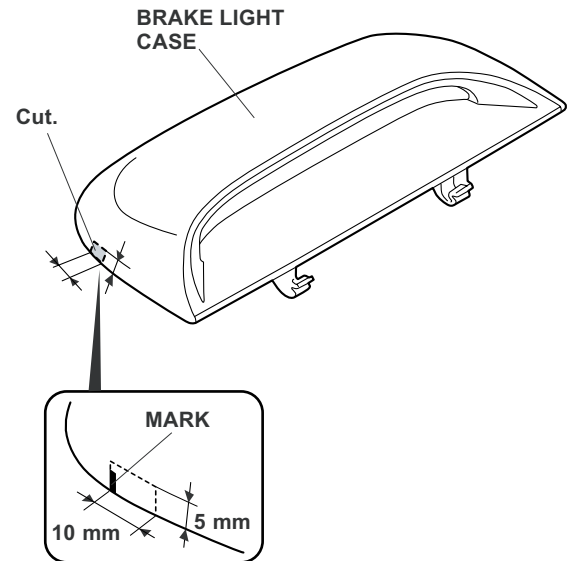

72. Route the antenna cable along the vehicle harness, and secure it to the vehicle harness with seven wire ties in the areas shown.

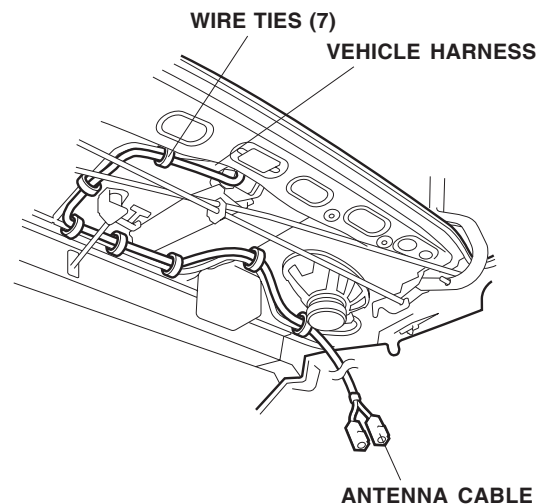

73. Secure the antenna cable, the DIN cable, and the XM radio harness with three wire ties with clips. Insert the clips on the wire ties into the panel holes.

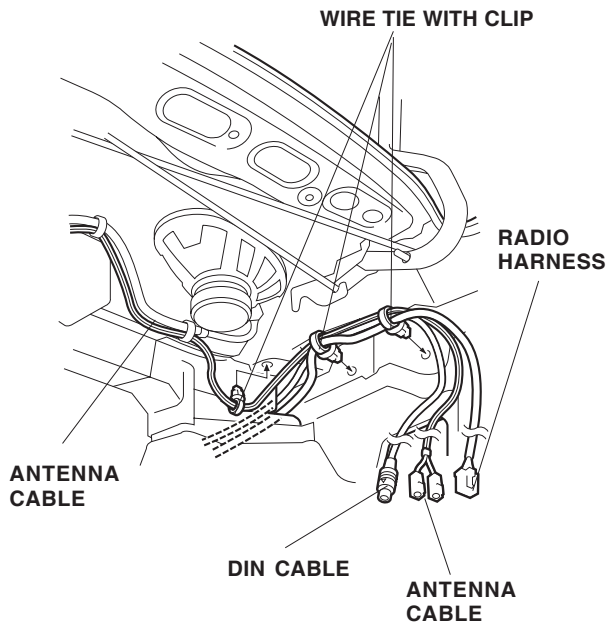

74. Using scissors, cut out the shaded areas from the template.

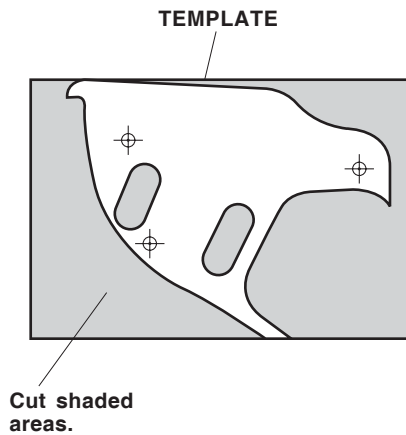

75. Position the template on the right trunk side panel, and tape the template in place. While wearing eye protection, center punch the three cross marks on the template.

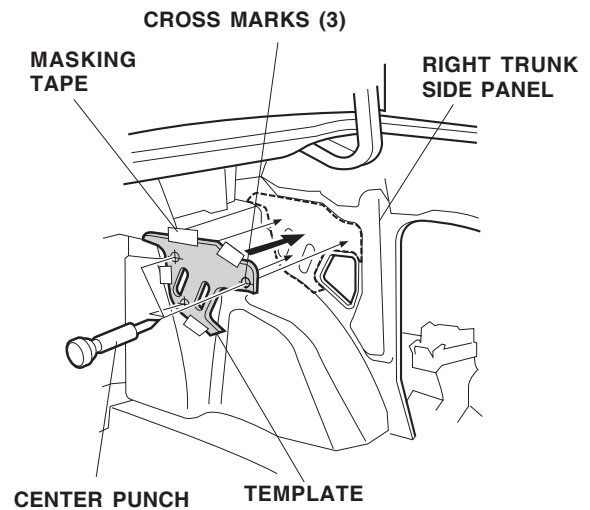

76. Remove the template. Place a shop towel on the inside of the right trunk side panel to collect any metal shavings.

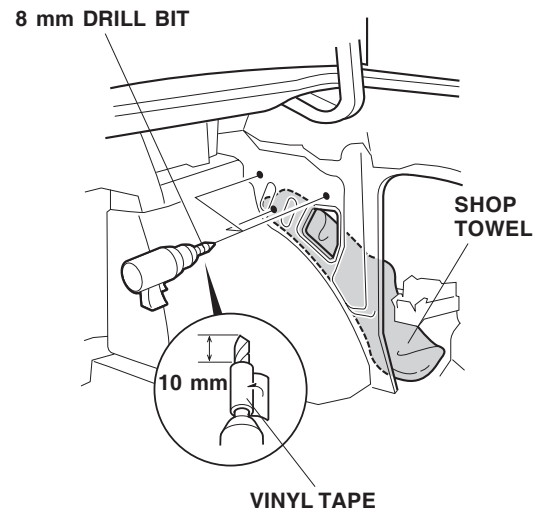

77. Drill three 8 mm holes through the inner panel:
- Wrap vinyl tape around the drill bit 10 mm from the end, or attach a drill stop.
 - While wearing eye protection, drill an 8 mm hole through each center-punched mark.
 - Remove all burrs and metal shavings, and apply touch-up paint to the edges of each drilled hole.
 - Remove and discard the shop towel.

78. Install the front and rear unit brackets to the receiver unit using two 4 x 8 mm washer-screws and two 4 mm flange nuts for each bracket.

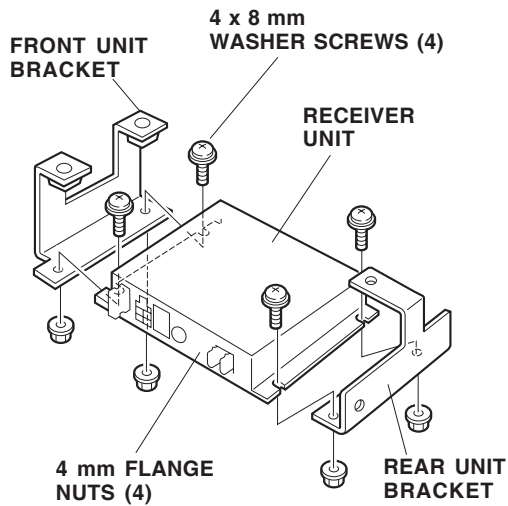

79. Position the receiver unit between the right trunk side panel and the rear fender panel, and plug in the antenna cable connectors, the DIN cable connector, and the XM radio harness connector using the panel hole to access the receiver unit.

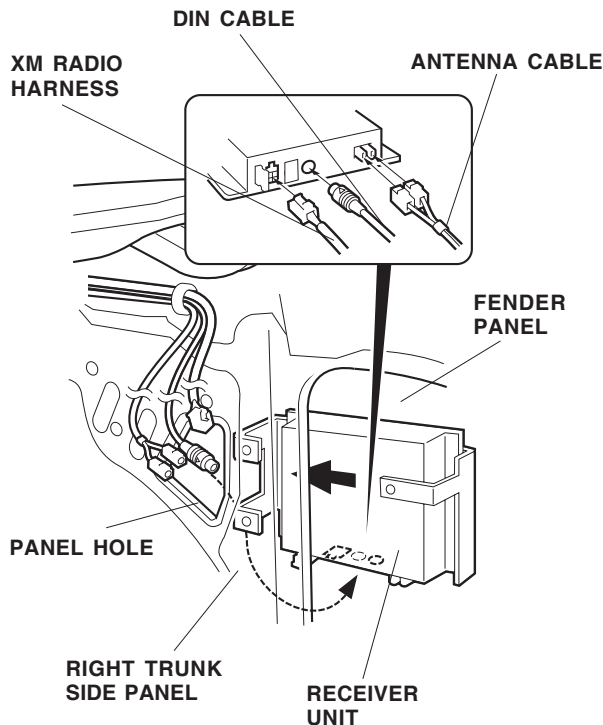

80. Attach the receiver unit to the body panel using three 6 x 12 mm washer-bolts. Tighten the bolts securely.

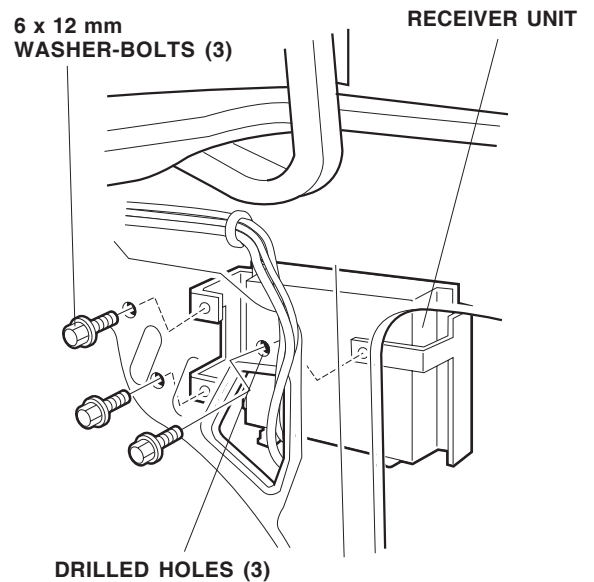

81. Attach two cushion tapes to the edges of the panel in the areas shown.

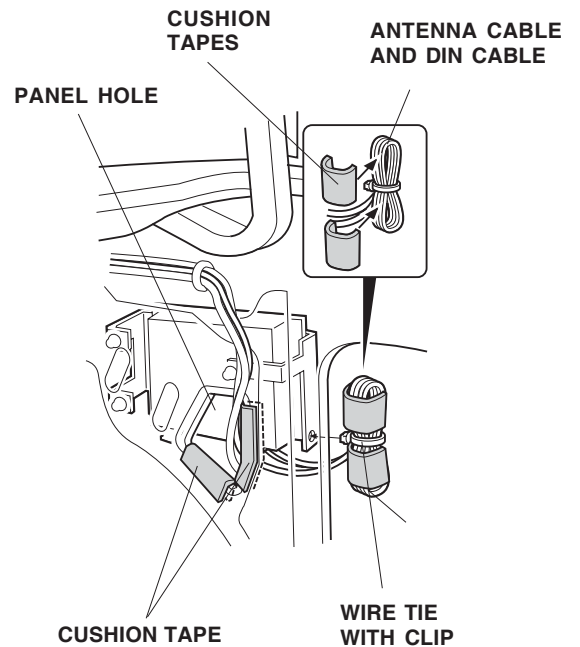

82. Inside the fender area, fold the excess antenna cable and DIN cable, and secure them with one wire tie with clip to the hole in the rear unit bracket.
83. Wrap the ends of the antenna cable and the DIN cable with two cushion tapes.

84. Install the 5A fuse (provided) into the No. 33 slot of the fuse box.

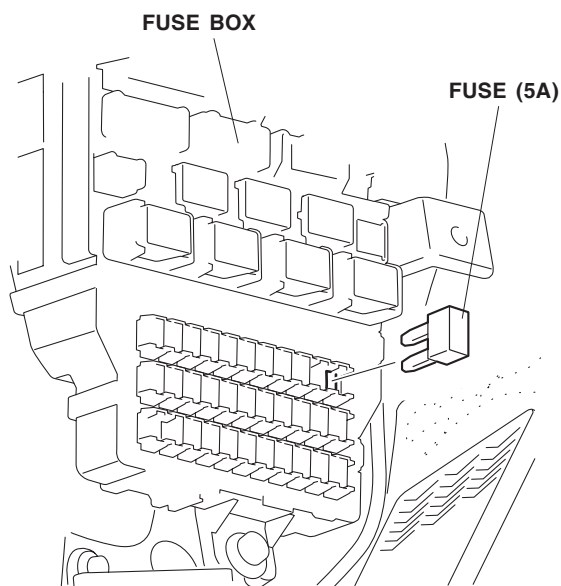

85. Attach the 5A fuse label over the No. 33 position on the fuse box cover.

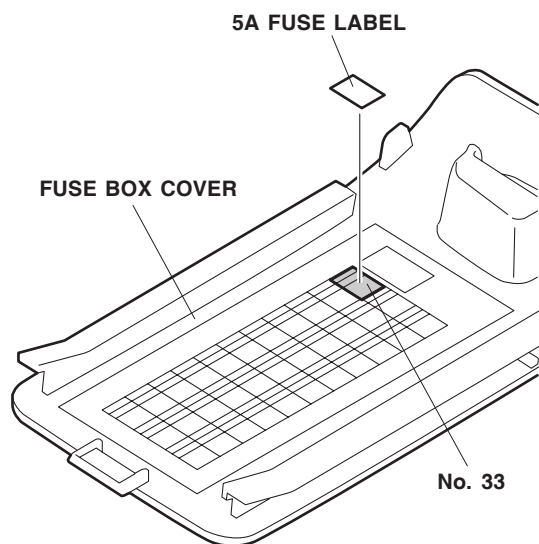

86. Check that all wire harnesses and cables are routed properly and all connectors are plugged in.
87. Reinstall all removed parts. Check that all clips and fasteners are installed securely.
88. Reconnect the negative cable to the battery.
89. Enter the radio anti-theft code, and reset the customer's radio station presets.
90. Set the clock.
91. Set one of the radio station presets to FM 88.7 and check the operation of the XM radio. If necessary, use the XM radio Owner's Manual supplied.

NOTE: Whenever the battery is disconnected, the driver's window AUTO up function is disabled.

92. Do the driver's window AUTO up procedure:
- Start the engine. Push down on the driver's window switch until the window is fully open.
 - Pull up on the driver's window switch to close the window completely, and hold the switch for 2 seconds.
 - Test the window AUTO up function.