



INSTALLATION INSTRUCTIONS

Accessory
**REMOTE CONTROL
ENGINE STARTER**

Application
**2008 ACCORD
2-DOOR
(AT ONLY)**

Publications No.
All 38576-38846

Issue Date
FEB 2008

PARTS LIST

Remote Engine Starter Unit Kit P/N 08E91-E22-100A

Transmitter

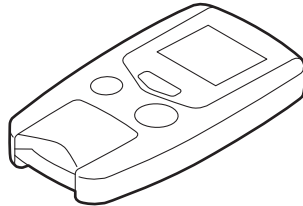

Control unit

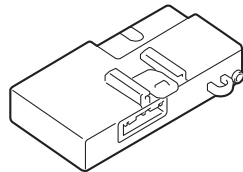

Antenna

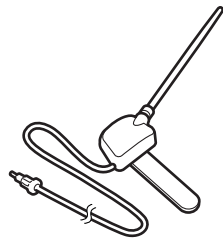

Key ring



Protective tape



Caution label



Fuse label

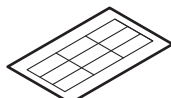

Accessory User's Information Manual

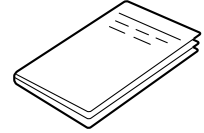

Quick start guide

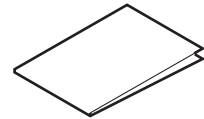

Remote Control Engine Starter Attachment Kit P/N 08E92-TA0-100

Engine starter harness

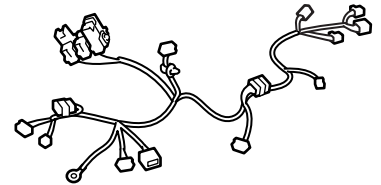

Control unit bracket



Template

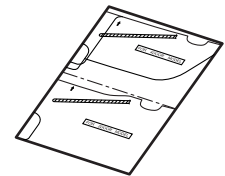

3 Relays

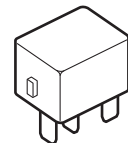

Flange nut



Ground bolt



20 Wire ties

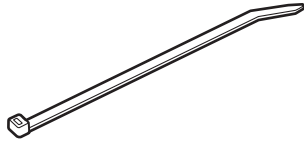

2 Long wire ties

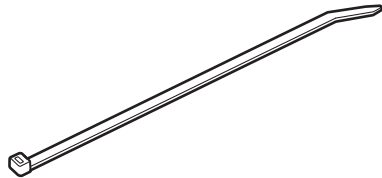

8 Urethane tapes

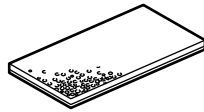

A-Pillar clip



TOOLS AND SUPPLIES REQUIRED

Flat-tip screwdriver
Phillips screwdriver
Small flat-tip screwdriver
Ratchet
10 mm Socket
10 mm Combination wrench
Isopropyl alcohol
Shop towel
Tape measure
Clip remover
Scissors
Small rubber mallet
Honda Diagnostic System (HDS)
Masking tape
Needle nose pliers

Illustration of the Engine Starter Installed on the Vehicle

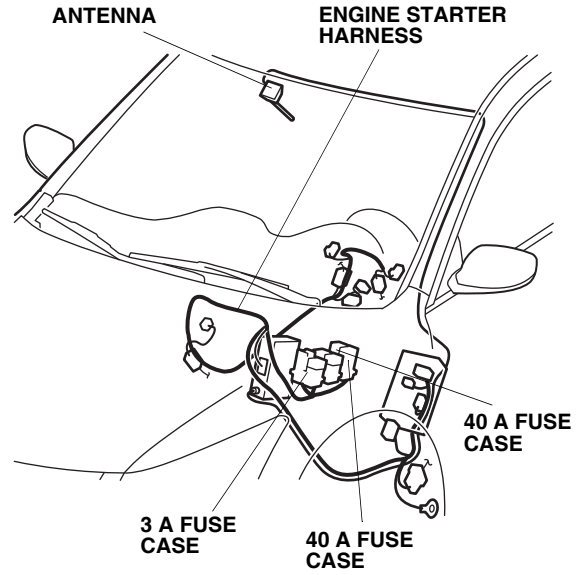

INSTALLATION

Customer Information: The information in this installation instruction is intended for use only by skilled technicians who have the proper tools, equipment, and training to correctly and safely add equipment to your vehicle. These procedures should not be attempted by “do-it-yourselfers.”

NOTE: This antenna should only be installed if the ambient air temperature 15°C (60°F) or above.

1. Make sure you have the anti-theft code for the radio, then write down the radio station presets.
2. Disconnect the negative cable from the battery.

Setting the Control Unit

- Using a small flat-tip screwdriver, adjust the switches on the (accessory) control unit to the locations shown. Using isopropyl alcohol on a shop towel, clean the area where the protective tape will attach control. Remove the adhesive backing, and attach the protective to the control unit.

NOTE:

- The switches must be selected before the control unit is plugged in.
- If the switch setting is not correct the remote engine starter will not operate correctly.
- If adjusting the switches with the control unit installed in the vehicle, touch the metal part of the screwdriver to any metal part of the vehicle to discharge any static electricity.
- If you change the switch settings with the unit connected, you must disconnect the unit then reconnect it before the settings change.

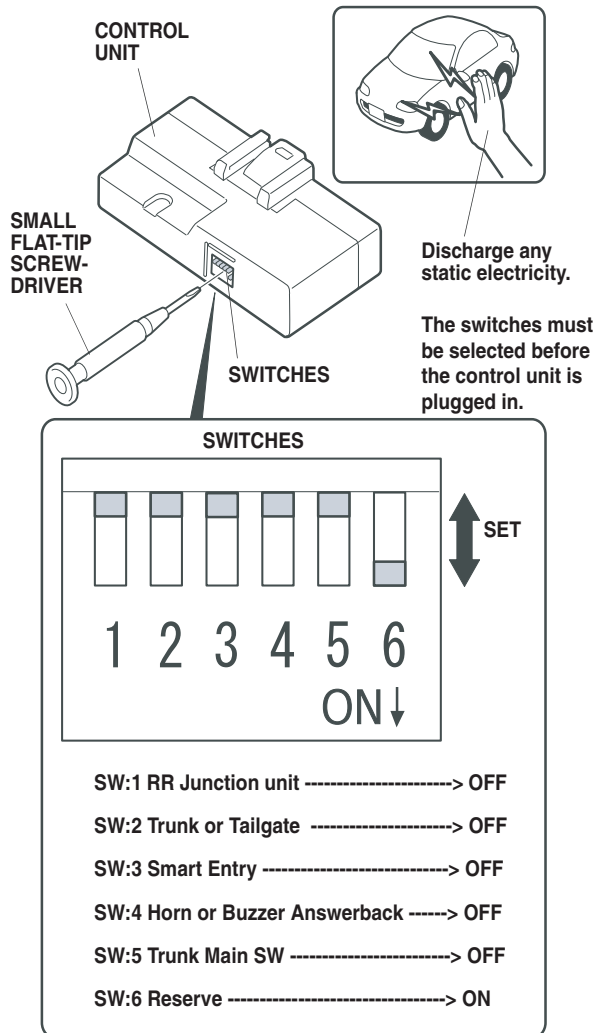

SW:1 RR Junction Unit

SW:2 Trunk or Tailgate

SW:3 Smart Entry

SW:4 Horn or Buzzer Answer Back

SW:5 Trunk Main SW

SW:6 Reserve

- Remove the driver's dashboard lower cover (eight clips, two hooks, and disconnect the vehicle connector).

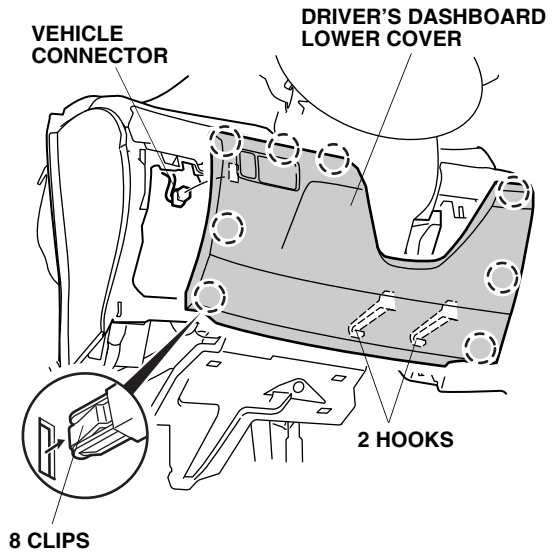

- V6 Model only: remove the driver's dashboard under cover (three clips and one pin).

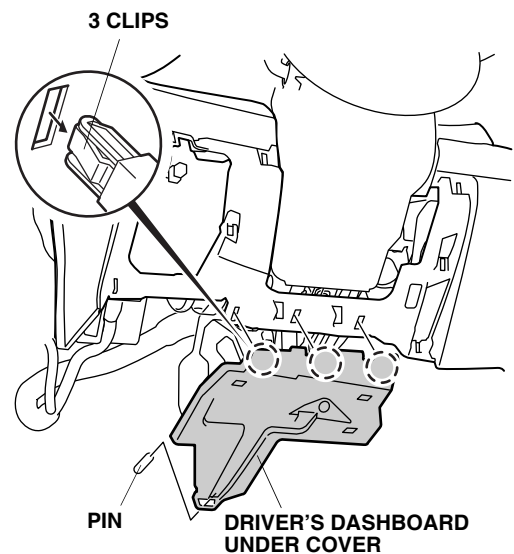

- Remove the cover from the trunk lid/fuel fill door opener (six retaining tabs), and remove one self-tapping screw. Make sure the trunk lid/fuel fill door opener is unlocked.

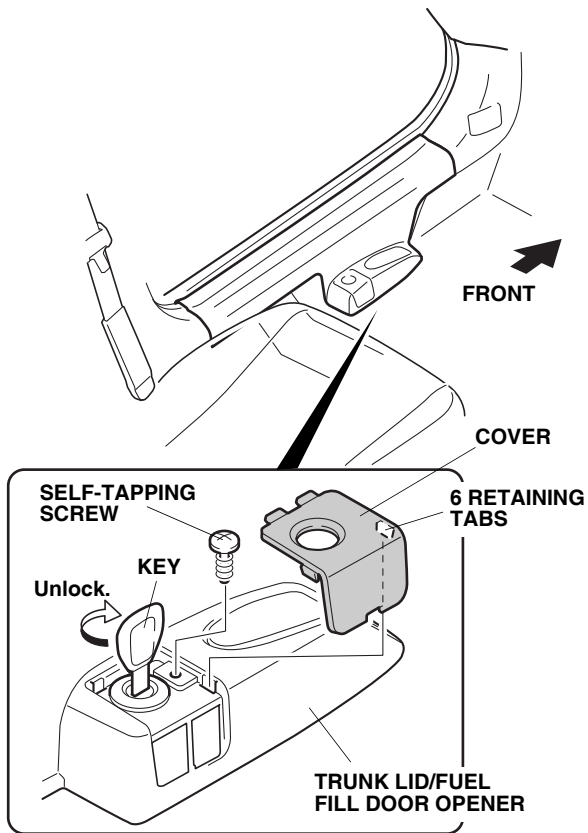

- Raise the front portion of the left front door sill trim (six clips, one retaining tab, and one hook).

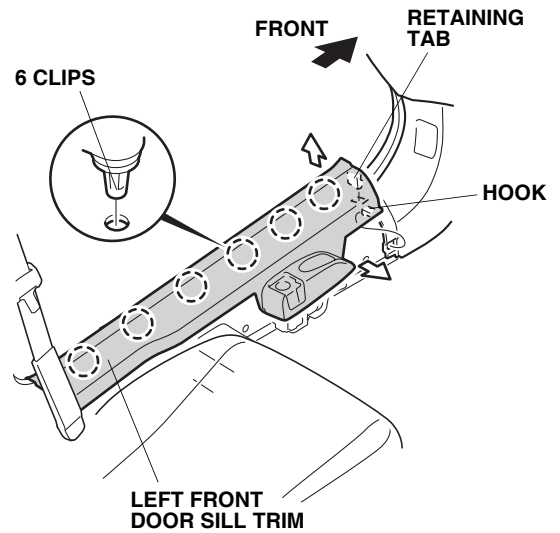

- Pull away the weatherstrip, and remove the left kick panel (two clips).

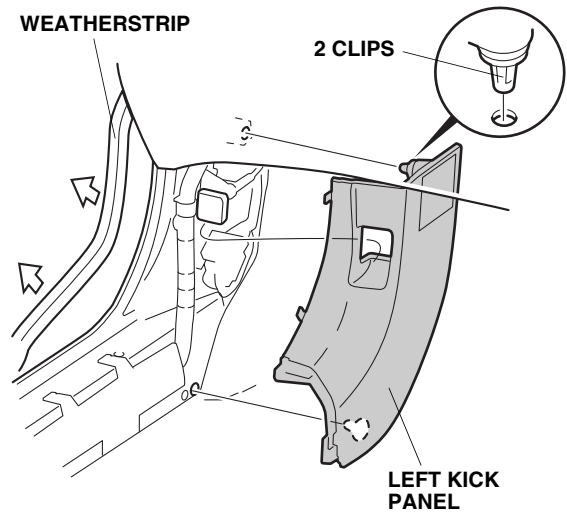

9. Pull away the weatherstrip and remove the left dashboard side cover (seven retaining tabs and three hooks).

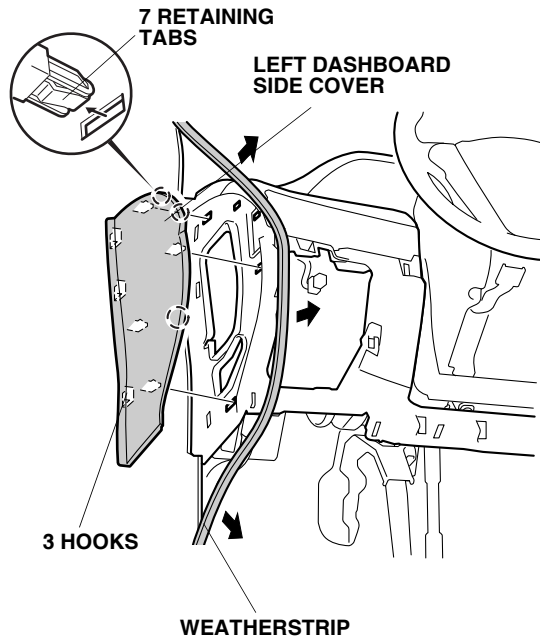

10. Lower the tilt lever and pull the steering wheel out.
11. Remove the upper steering column cover:
 - Insert a flat-tip screwdriver along the column guide inside the lower cover, and gently pry out on the retaining tab of the upper column cover.
 - Push the lower cover in at the areas shown to release the two retaining tabs, and pull up on the upper cover to release the two hooks.

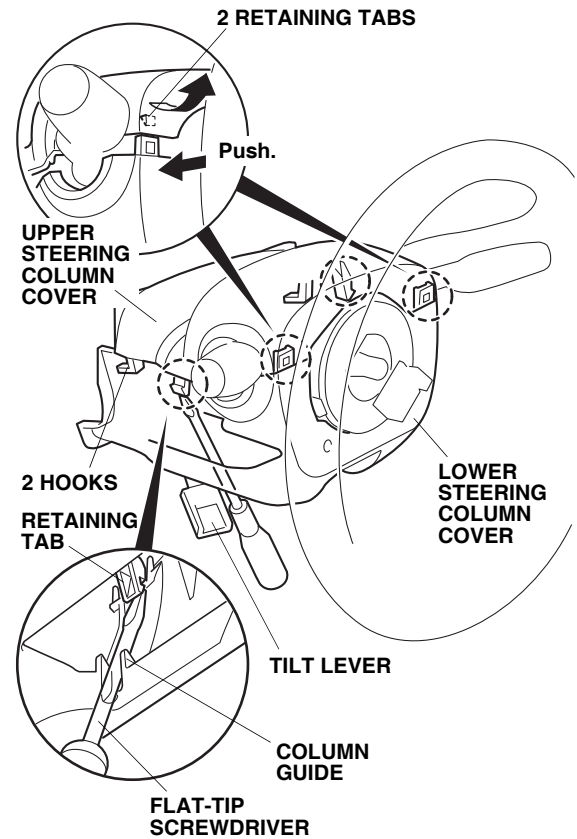

12. Remove the lower steering column cover (three screws). The upper screws are self-tapping screws.

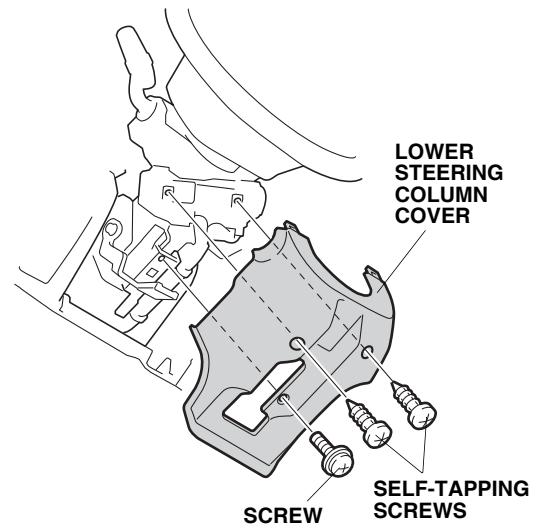

13. Remove the roof console:
- Using a small flat-tip screwdriver wrapped with a shop towel, pry out and remove the left and right lens (four retaining tabs each).

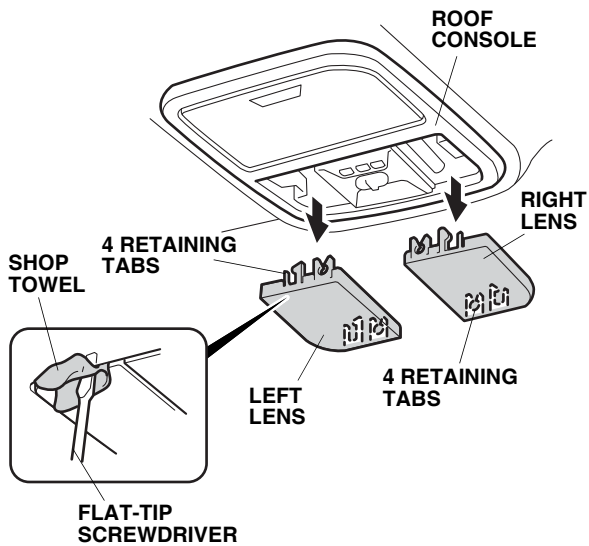

- Open the sunglasses holder and remove the four screws.
- Disconnect the vehicle connectors to remove the roof console.

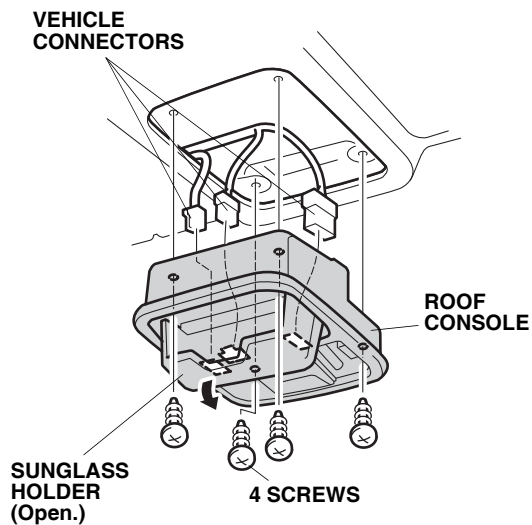

14. Turn the sunvisor holder 45°, and remove the two sunvisor holders.

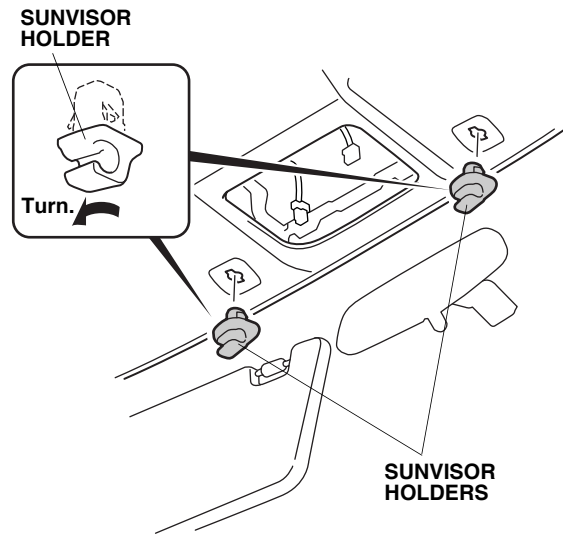

15. Remove the driver's sunvisor.
- Turn the left sunvisor toward the driver's seat.
 - Locate the slot in the sunvisor holder, and insert a flat-tip screwdriver into the slot. Push in and hold the retaining tab.
 - While holding the retaining tab, push up on the left sunvisor and rotate toward the door to remove.

NOTE: If the retaining tab did not stay pushed in, return the left sunvisor to its original position and repeat the steps above.

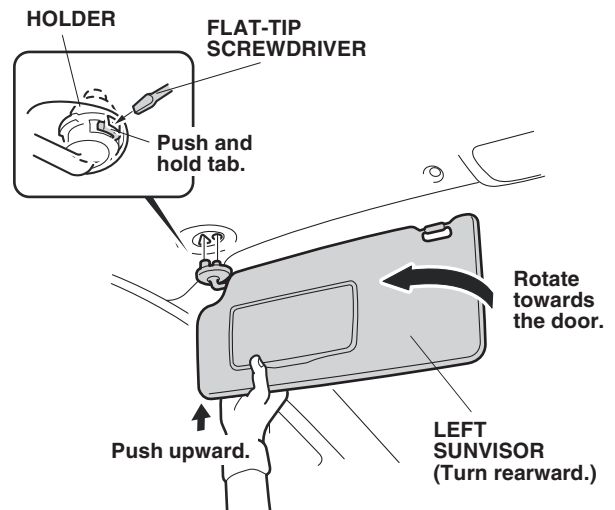

16. Pull away the weatherstrip from the left front A-pillar trim.

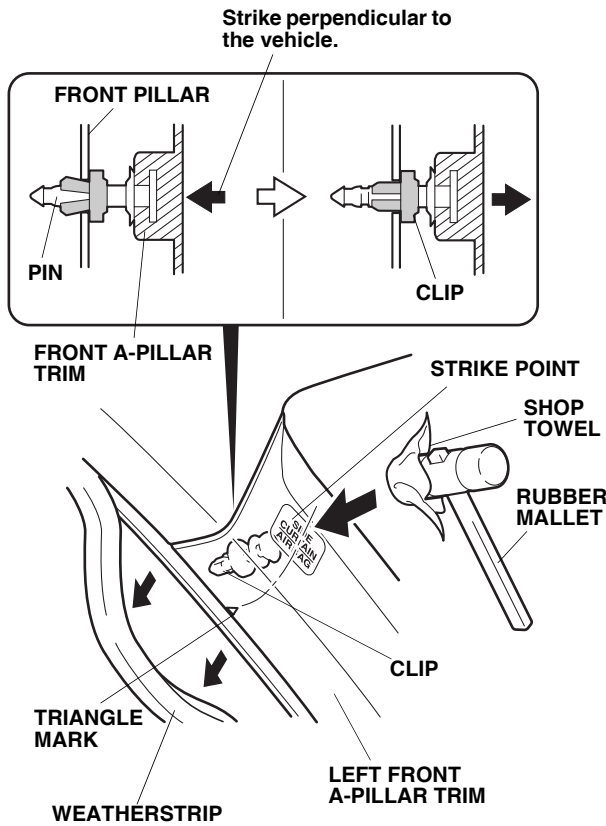

17. Using a small rubber mallet and a shop towel, gently tap the left front A-pillar trim at the position shown to release the clip.
18. Pull away the weatherstrip from the left front A-pillar trim. Remove the left front A-pillar trim (two clips).

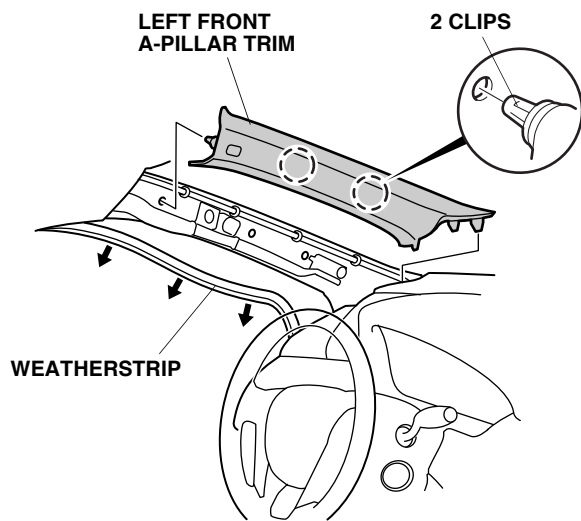

19. Remove and discard the clip from the left front A-pillar trim, and install a new A-pillar clip (supplied) on the left front A-pillar trim.

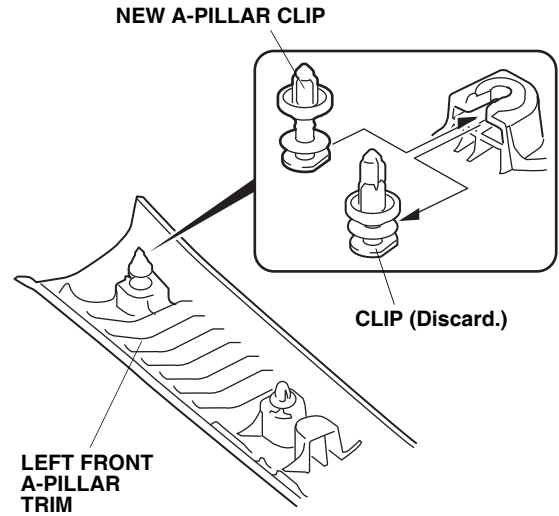

20. If equipped remove the HandsFreeLink control unit (two bolts and disconnect the vehicle 28-pin connector).

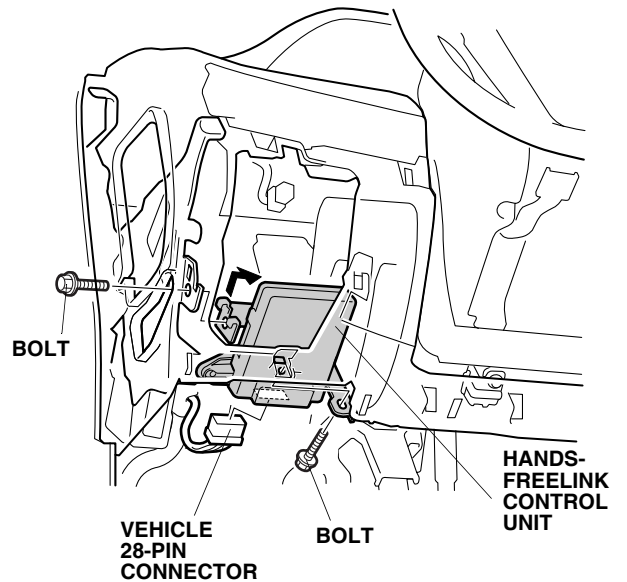

Routing the Engine Starter Harness

21. Attach the two 40 A fuse labels to the engine starter fuse block.

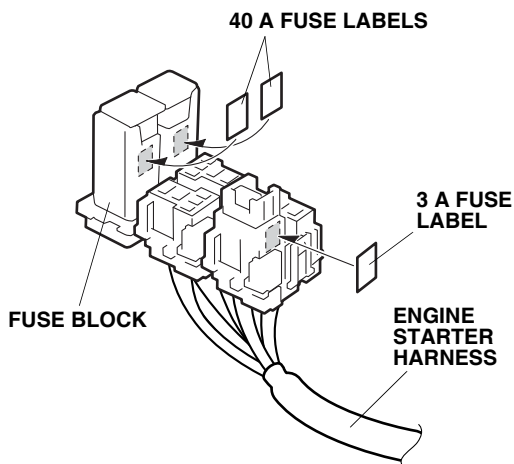

22. Attach the 3 A fuse label to the engine starter relay block.
23. Install the three relays to the engine starter relay blocks.

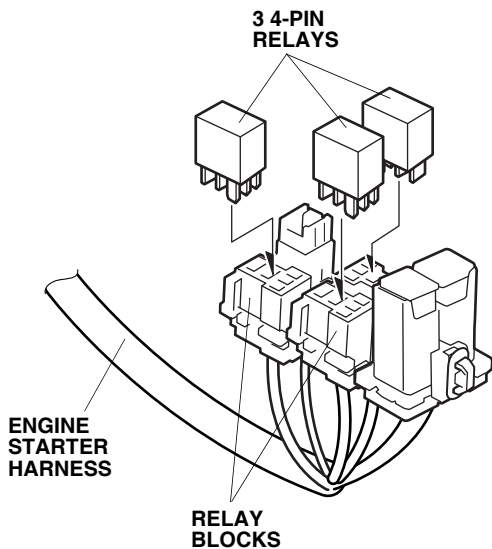

24. Remove the vehicle bolt and remove the TPMS control unit from the vehicle bracket.

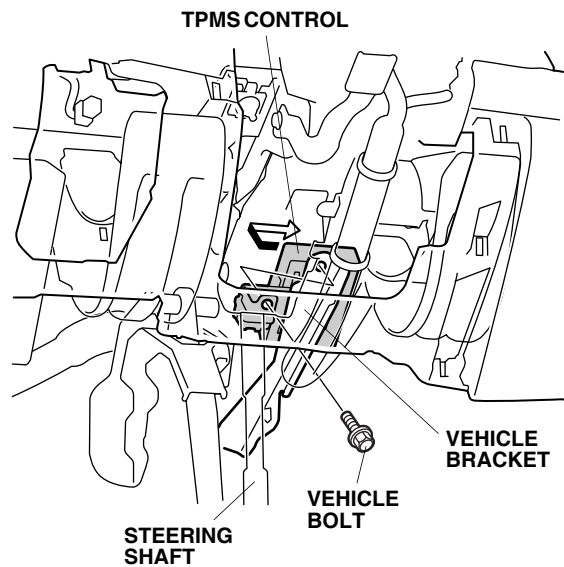

25. Route the 12-pin/8-pin/5-pin connector end of the engine starter harness over the brake pedal bracket towards the center of the vehicle.

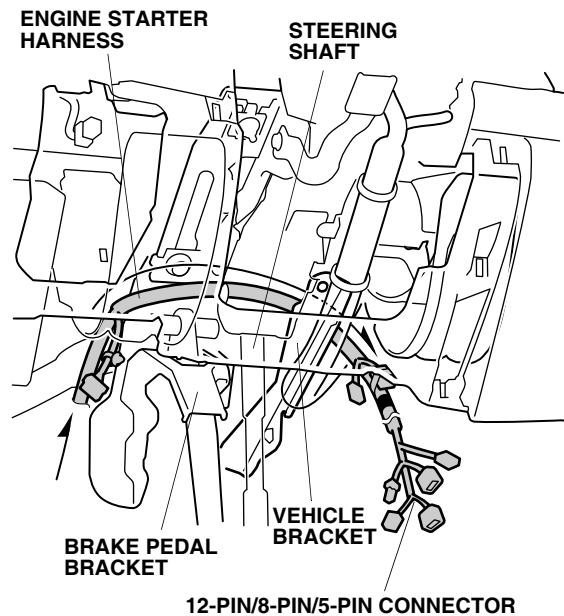

26. Route the 12-pin/8-pin/5-pin connector end of the engine starter harness to the ignition switch.

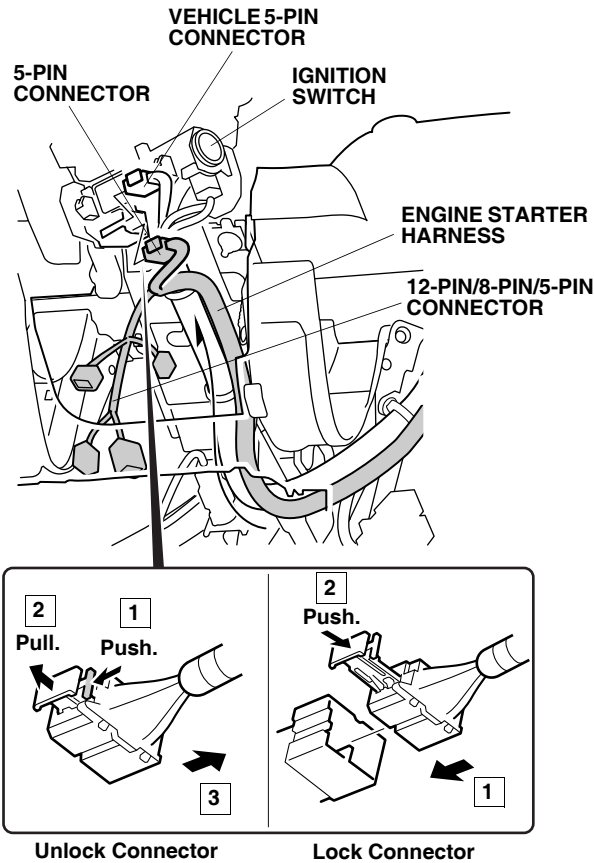

27. Disconnect the vehicle 5-pin connector from the ignition switch, and plug the engine starter harness 5-pin connector into the ignition switch.
- NOTE: Check that the engine starter harness 5-pin connector is connected to the vehicle connector and locked securely. A loose connector can cause the engine to stall

28. Wrap one urethane tape around the vehicle 5-pin connector, and tuck it into the area shown.

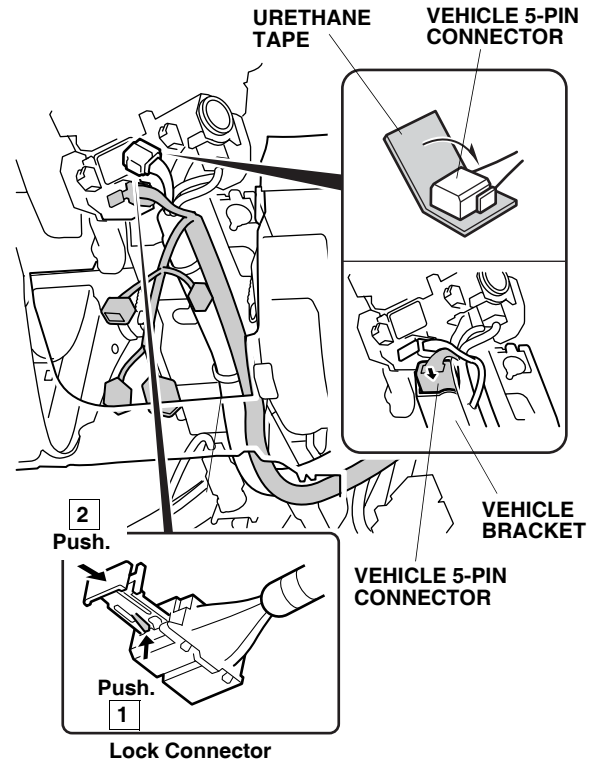

29. Disconnect the turn signal switch 12-pin connector and plug it into the engine starter harness 12-pin connector. Plug the remaining engine starter harness 12-pin connector into the turn signal switch.

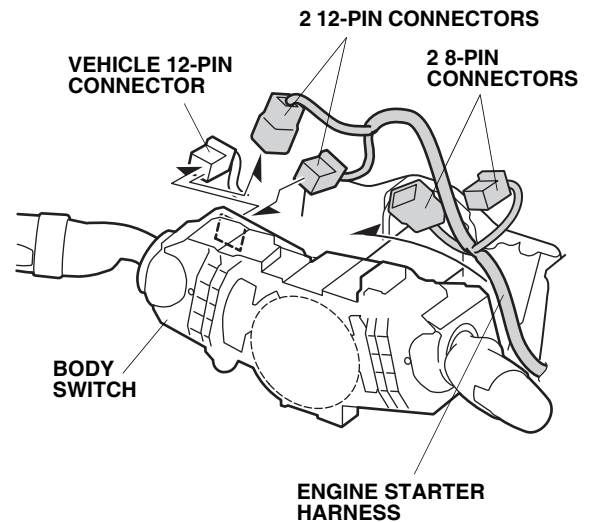

30. Disconnect the vehicle 8-pin connector and plug it into the engine starter harness 8-pin connector. Plug the remaining engine starter harness 8-pin connector into the wiper switch.

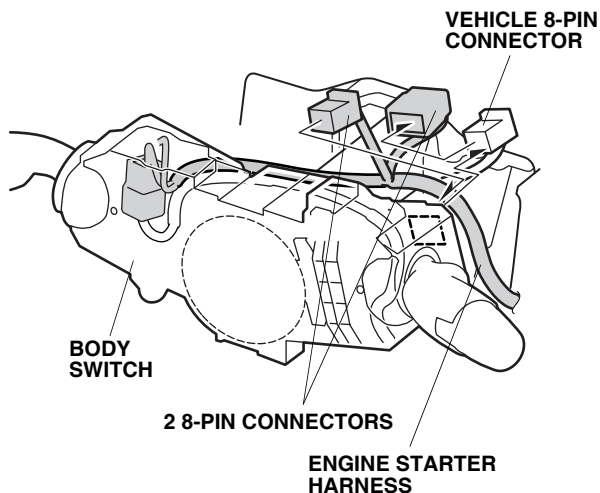

31. Secure the engine starter harness to the vehicle harness using two wire ties. Do not secure to the SRS harness.

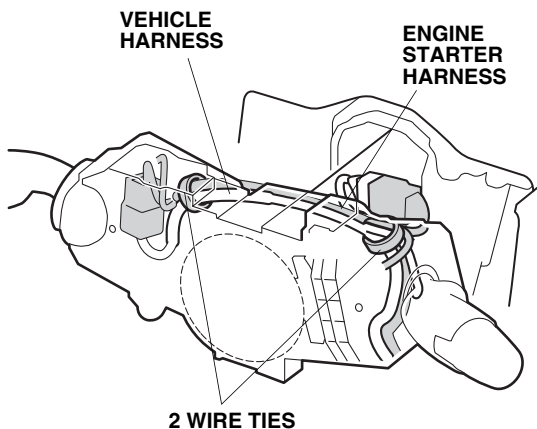

32. Secure the engine starter harness to the vehicle harness with two wire ties in the areas shown.

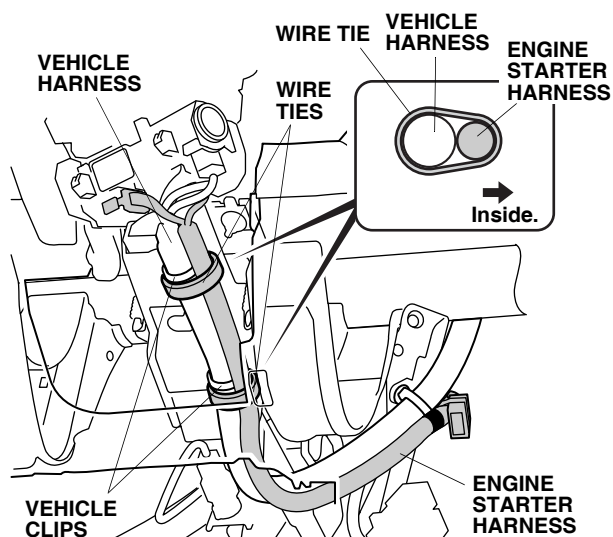

33. Disconnect the vehicle 20-pin connector from the TPMS control unit (removed in step 24) and plug it into the engine starter harness 20-pin connector. Plug the remaining engine starter harness 20-pin connector into the TPMS control unit.

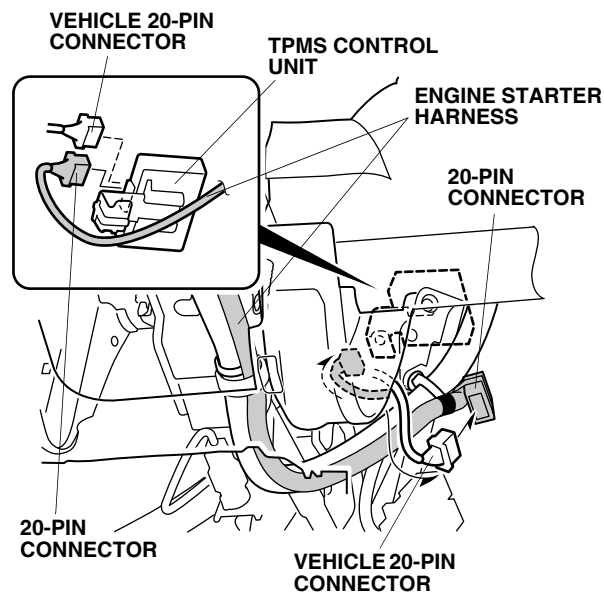

34. Align the green tape on the engine starter harness with the clip on the vehicle harness, and secure the engine starter harness to the vehicle harness with one wire tie.

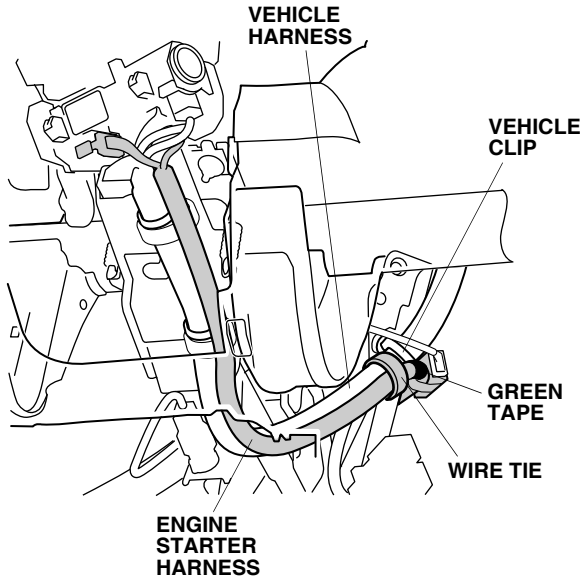

35. Near the connector, secure the engine starter harness to the vehicle harness with one wire tie.

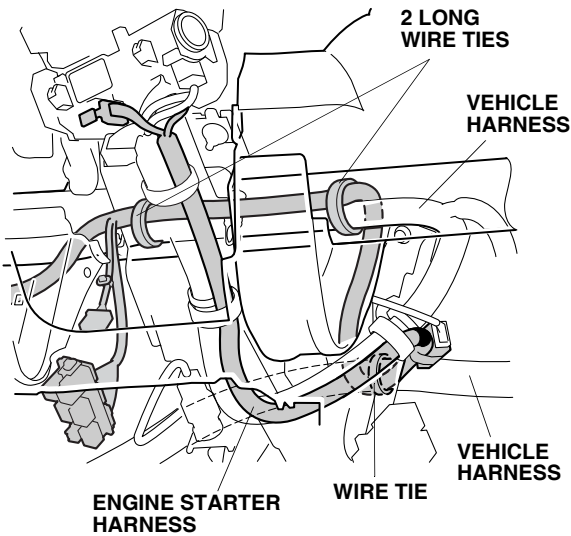

36. Secure the engine starter harness to the vehicle harness with two long wire ties at the locations shown.
37. Reinstall the vehicle unit to the vehicle bracket using the vehicle bolt removed in step 24.

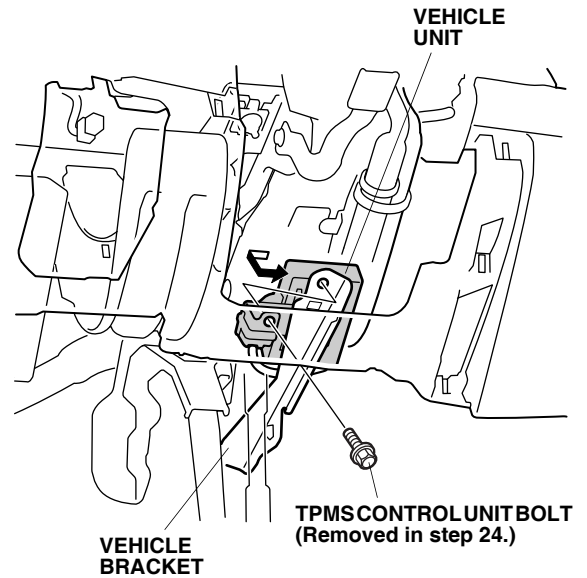

38. Route the engine starter harness along the vehicle harness to the front of the fuse box.
39. Loosely attach the engine starter harness to the vehicle harness with one wire tie.

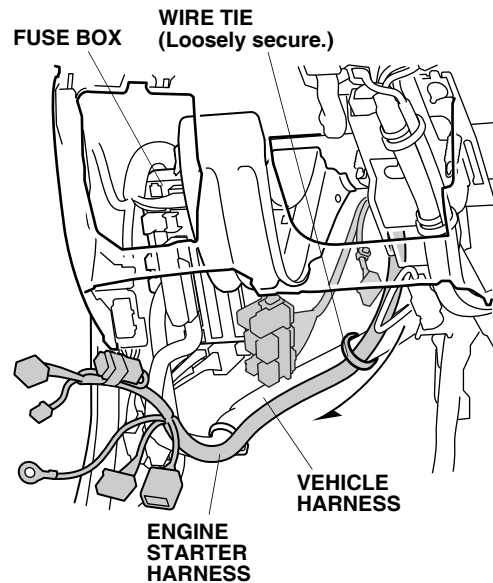

40. Disconnect the vehicle 5-pin connector from the fuse box. Plug the engine starter harness 5-pin connector into the fuse box 5-pin connector. Wrap one urethane tape around the vehicle 5-pin connector. **NOTE:** Check that the engine starter harness 5-pin connector is connected to the vehicle connector and locked securely. A loose connector can cause the engine to stall.

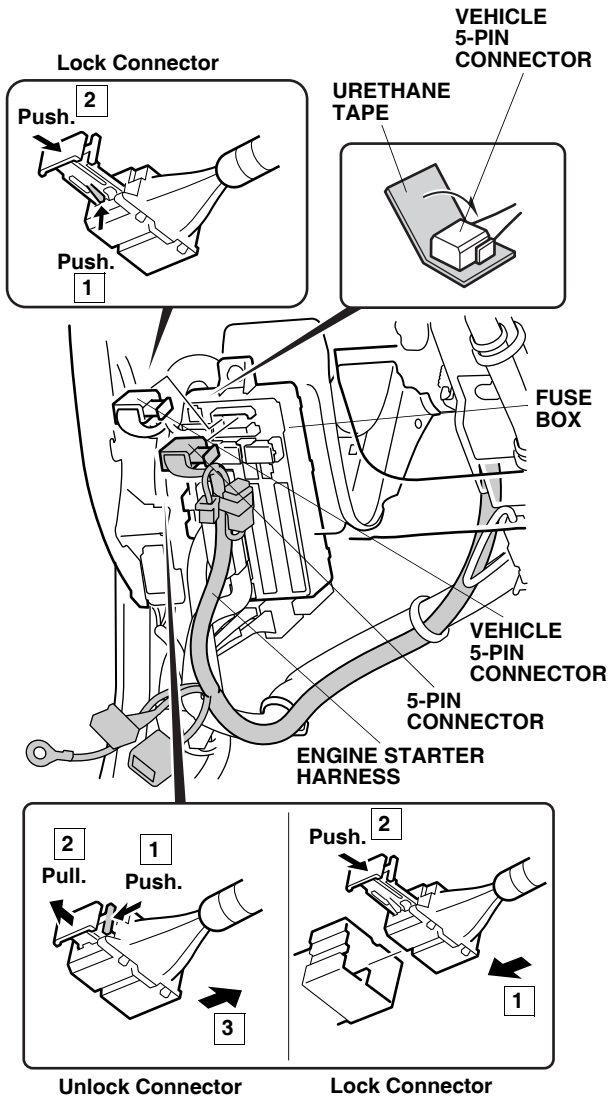

41. Plug the engine starter harness 12-pin connector into the fuse box 12-pin connector.

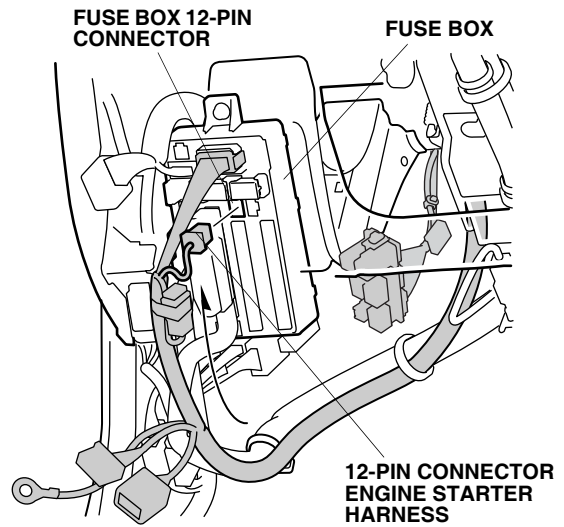

NOTE: If the 12-pin connector is already being used, unplug the 12-pin connector from the fuse box, and plug the engine starter harness 12-pin into the fuse box. Remove and discard the dummy connector from the engine starter harness and plug 12-pin connector into the engine starter harness.

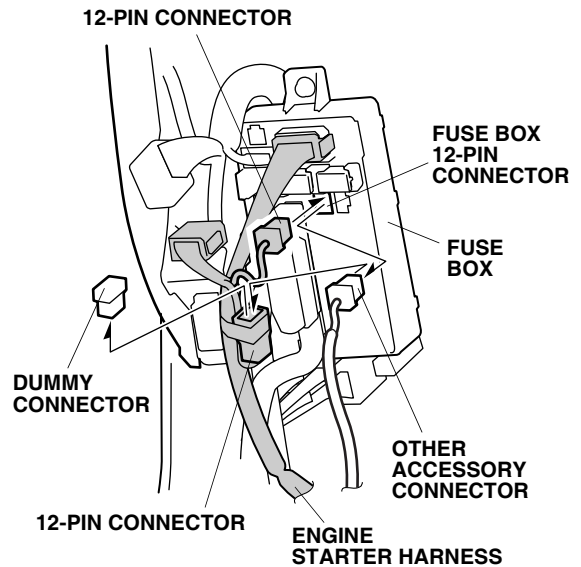

42. Loosely attach the engine starter harness to the vehicle harness with one wire tie.

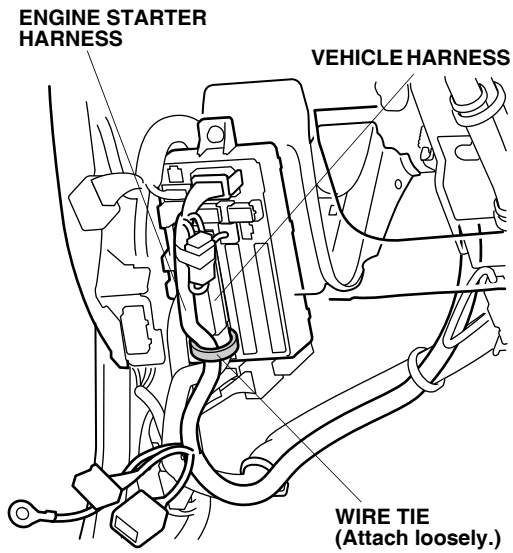

43. Disconnect the vehicle 20-pin connector from the fuse box, and plug it into the engine starter harness 20-pin connector. Plug the remaining engine starter harness into fuse box 20-pin connector.

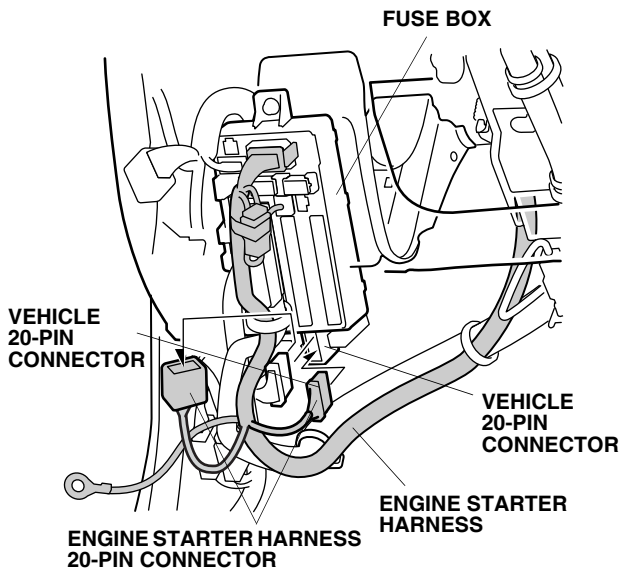

44. Attach the clip from the engine starter harness connector to the clip on the vehicle connector.

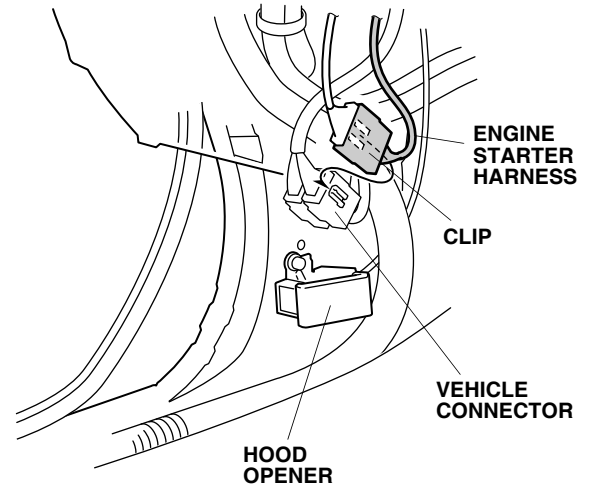

45. Remove and discard the upper hood opener bolt, and install the ground bolt supplied with the ground terminal attached.

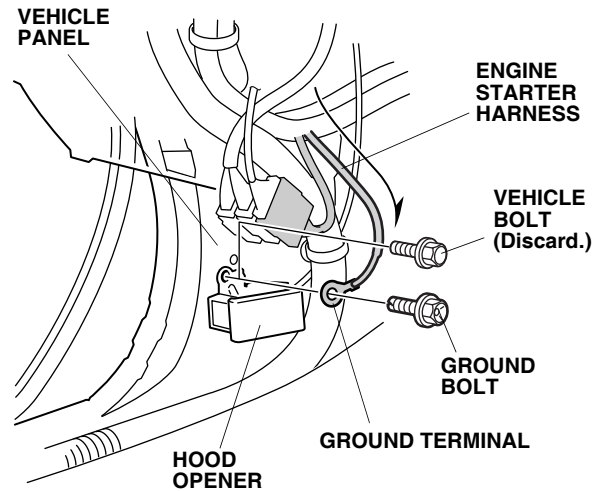

46. Secure the engine starter harness to the vehicle harness with one wire tie.

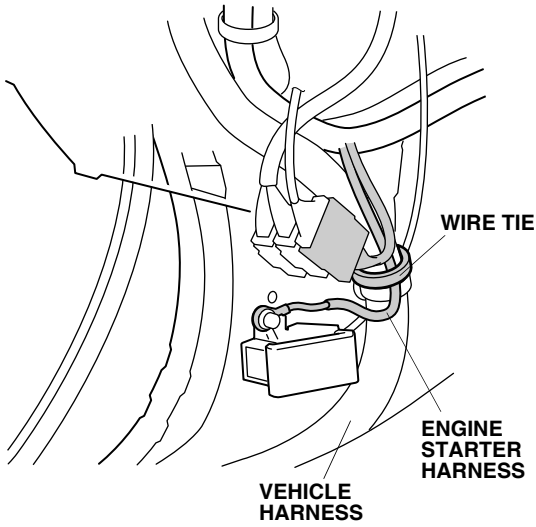

47. Loosely attach the engine starter harness to the vehicle harness with two wire ties.

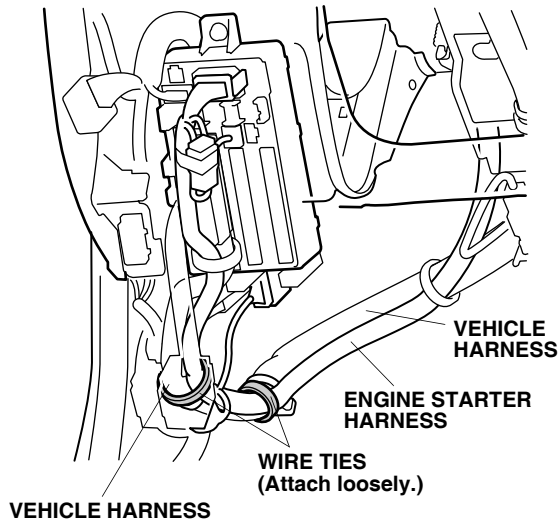

Installing the Antenna

48. Using scissors, separate the templates.

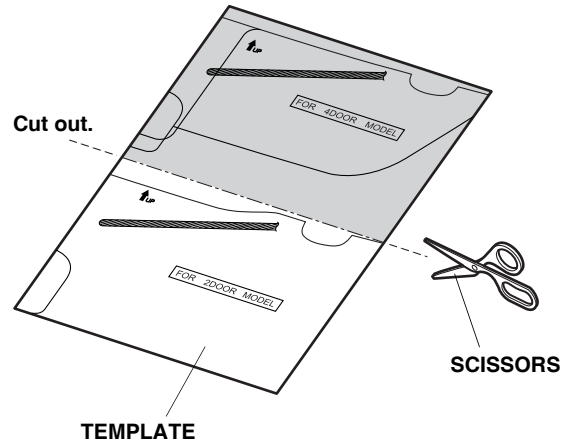

49. Using scissors, cut out the appropriate template.

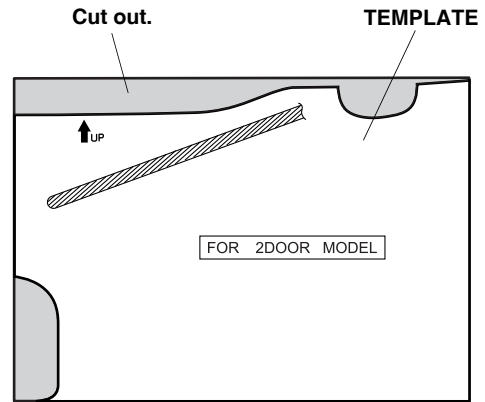

50. Using two pairs of needle nose pliers, bend the antenna plate according to the dimensions shown.

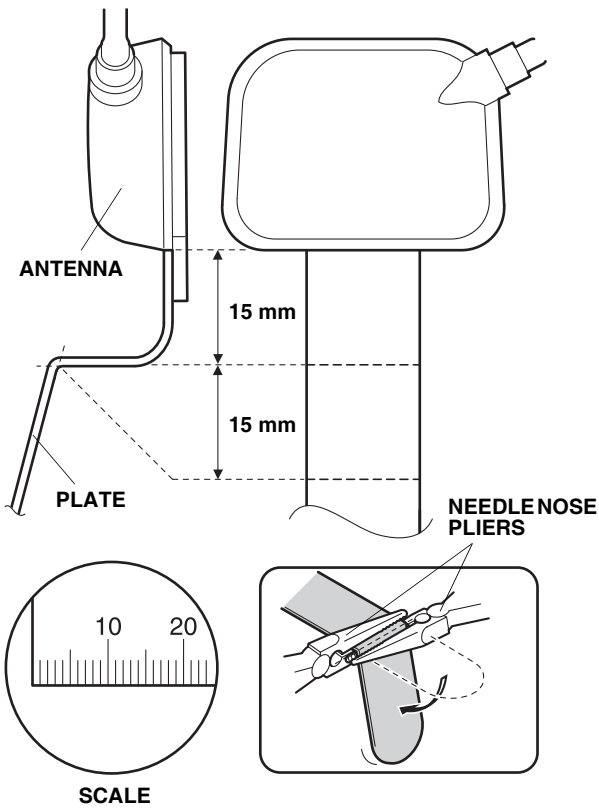

51. Starting near the antenna end of the cable, wrap three foam cushions around the antenna cable at the measurements shown.

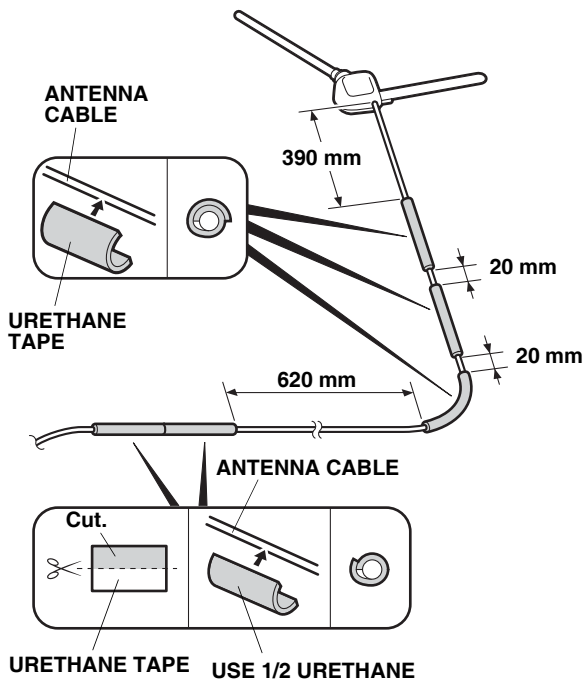

52. Using scissors, cut one foam cushion in half. Wrap the two halves of the foam cushion around the antenna cable at the measurements shown.
53. Attach the template to the front window.

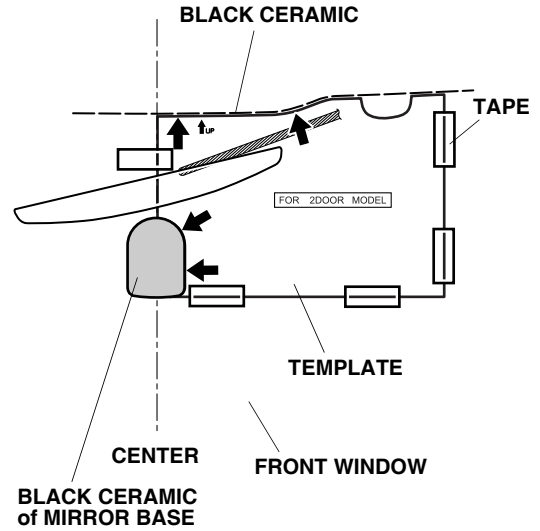

54. Using isopropyl alcohol on a shop towel, clean the windshield where the antenna will attach.

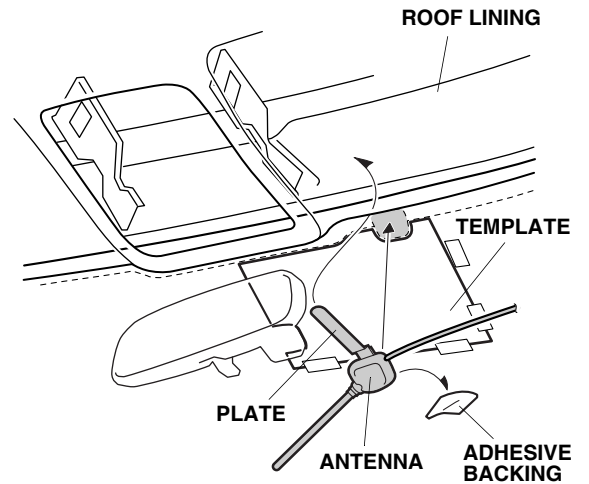

55. Remove the adhesive backing from the antenna. Insert the antenna plate over the roof lining, and attach the antenna to the front window aligning it with the template.
56. Remove the template.
57. Gently pull down the roof liner, and tuck the antenna cable under it.

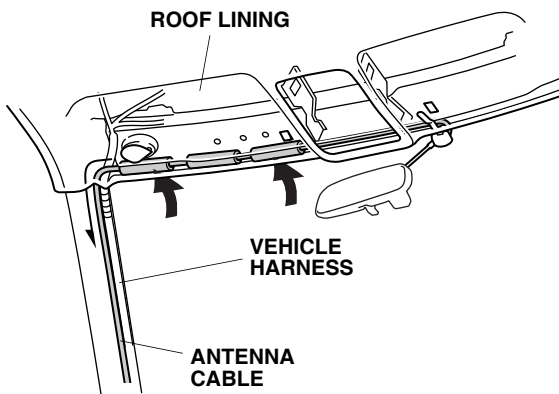

58. Using scissors, cut one foam cushion tape in half. Route the antenna cable towards the driver's side of the vehicle, and secure the antenna cable to the roof panel with the two halves of foam urethane tape.

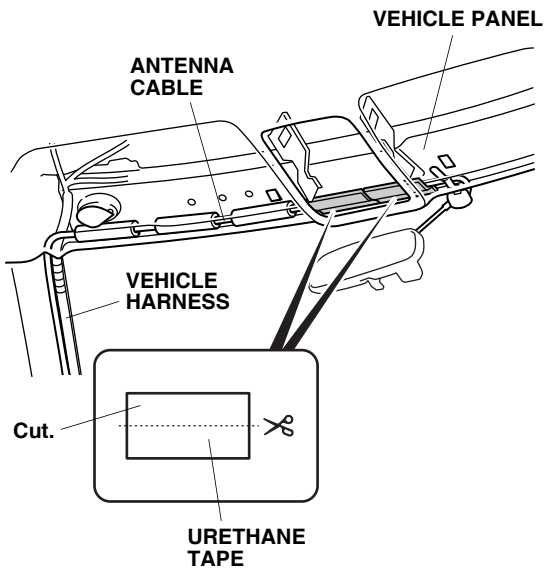

59. Pull away the weatherstrip, and route the antenna cable down and under the dashboard through the front pillar opening.

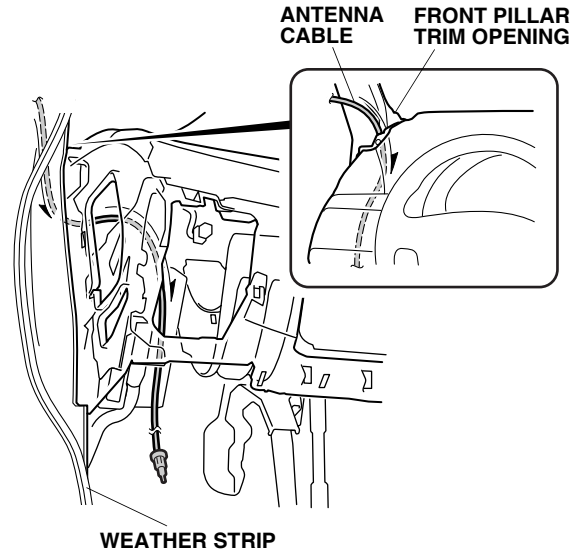

60. Secure the antenna cable to the vehicle harness with four wire ties.

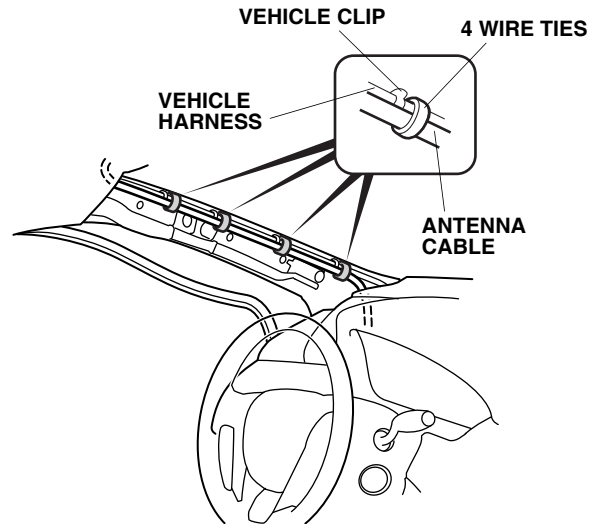

- Secure the vehicle 5-pin connector (disconnected in step 40) to the vehicle harness with one wire tie.

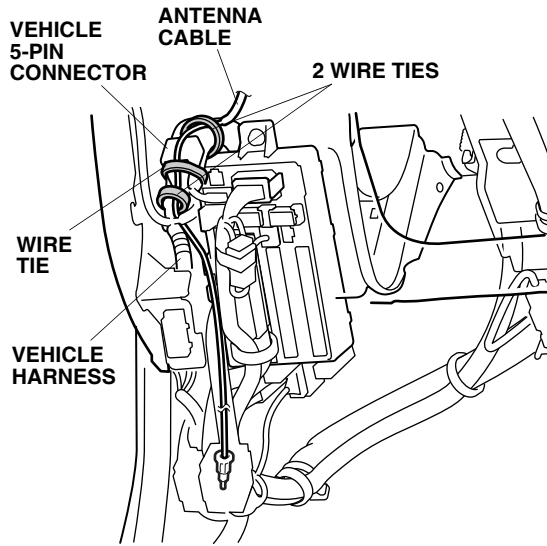

- Secure the antenna cable with two wire ties to the vehicle harness.
- Route the antenna cable along the engine starter harness.

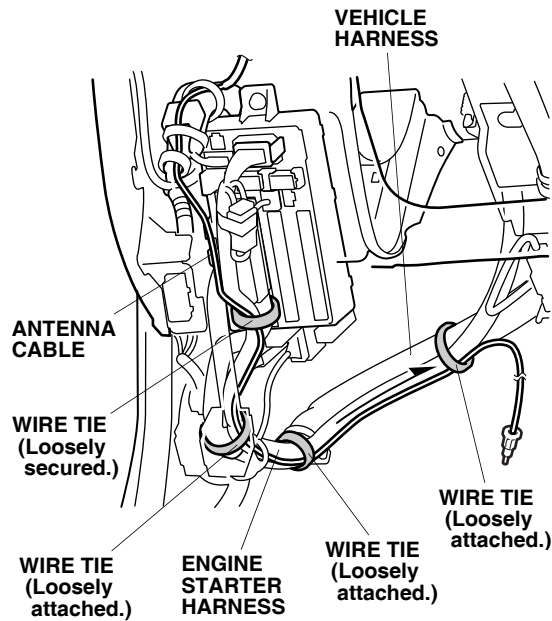

- Secure the antenna cable to the engine starter harness with the four wire ties you loosely attached.

Installing the Control Unit

- Install the control unit bracket to the control unit.

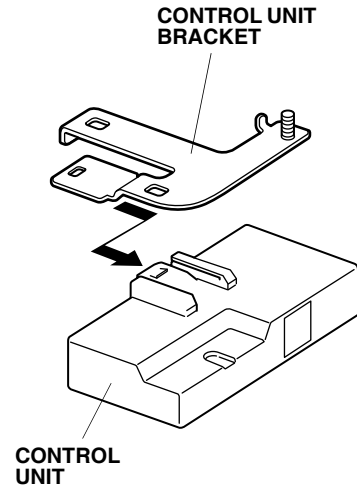

- Plug the engine starter harness 28-pin connector into the control unit.

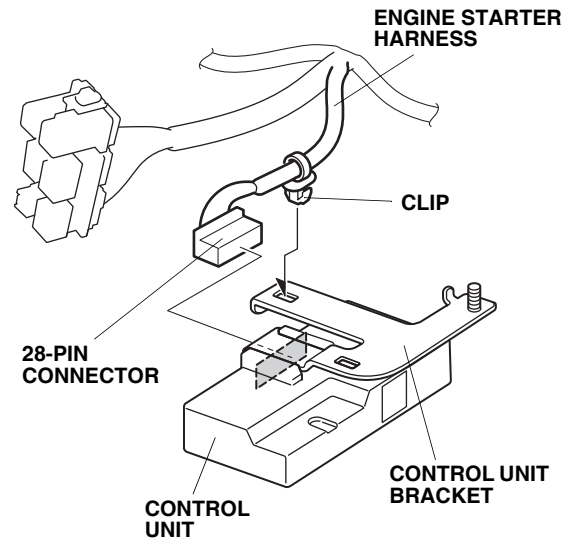

67. Install the clip from the engine starter harness to the control unit bracket.
68. Plug the antenna terminal into the control unit.

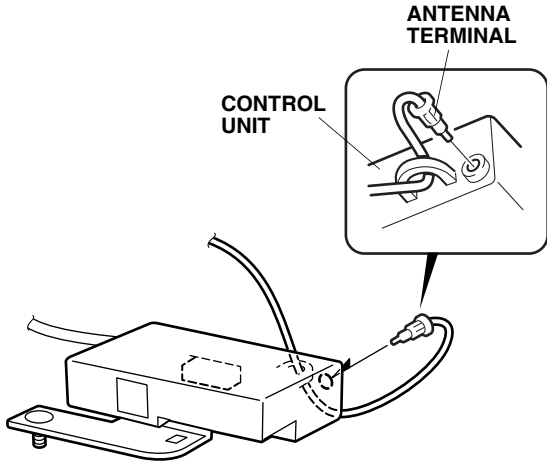

69. Secure the control unit to the vehicle frame using the flange nut.

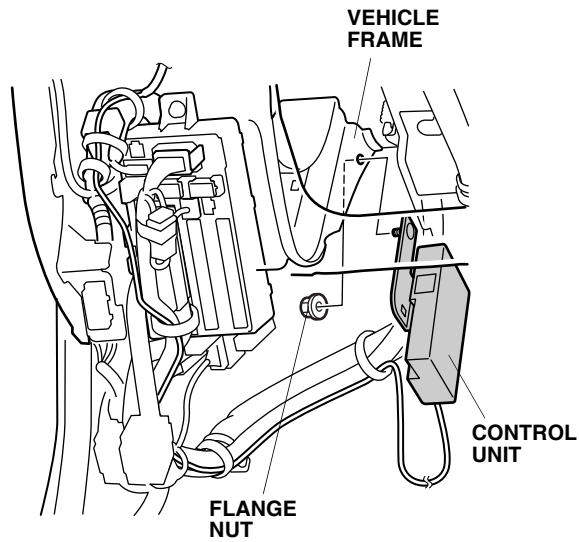

70. Wrap the urethane tape around the vehicle connector.

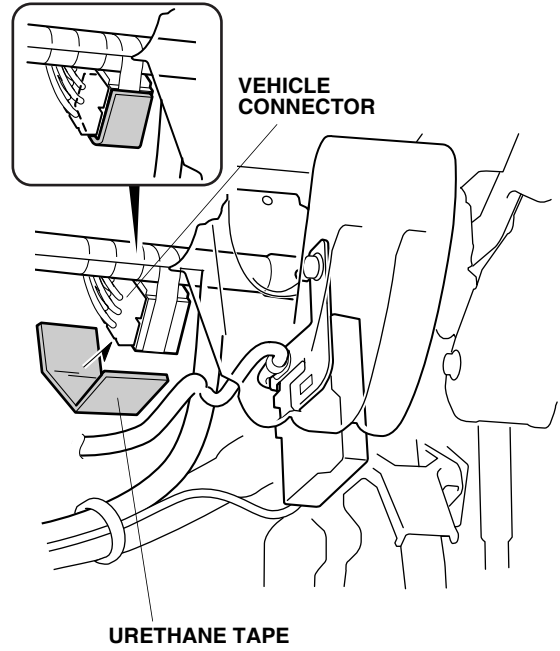

71. Attach the engine starter relay block clip to the vehicle frame.

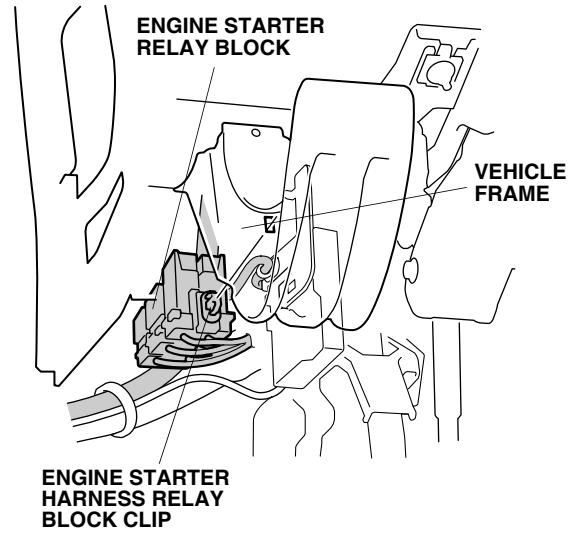

72. Bundle the excess antenna cable and secure it to the engine starter harness and the vehicle harness with the loosely installed wire tie.

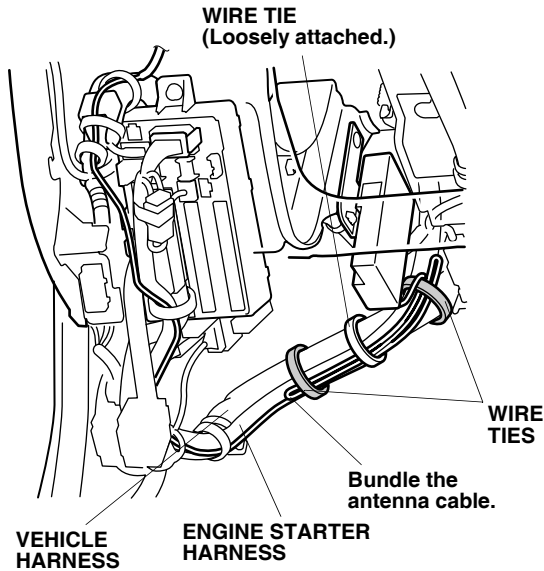

73. Secure the antenna cable to the engine starter harness with two additional wire ties.
74. Under the hood, locate the area where the caution label will attach. Using isopropyl alcohol on a shop towel, clean the hood where the caution label will attach.

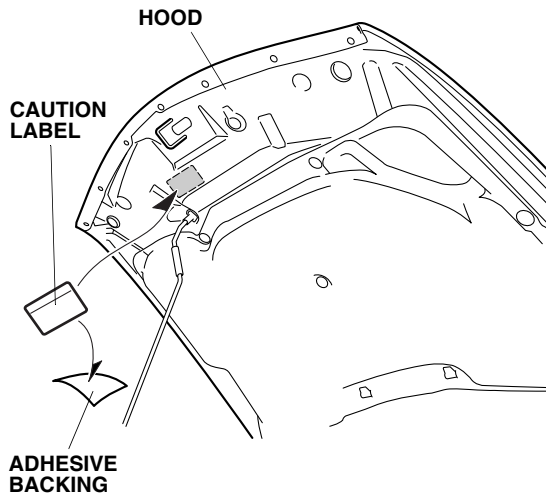

75. Attach the caution label to the hood in the area shown.
76. Reinstall all removed parts. Check that all clips and other fasteners are installed securely. Take care not to pinch the airbag with the clip during reinstallation of the front pillar trim. Do not push excessively on the front pillar trim.

77. Reconnect the negative cable to the battery.
78. Enter the customer's radio anti-theft code, and reset the radio station presets.
79. Reset the clock.
80. Do the **REMOTE ENGINE STARTER REGISTRATION** (page 19) and **FUNCTION CHECK** (page 22).

REMOTE ENGINE STARTER REGISTRATION

1. Acquire the PCM code from the Interactive Network.
2. Connect the HDS tester to the OBD II data link connector, then turn the ignition switch to the ON (II) position.
3. Start the HDS, and click the car icon.

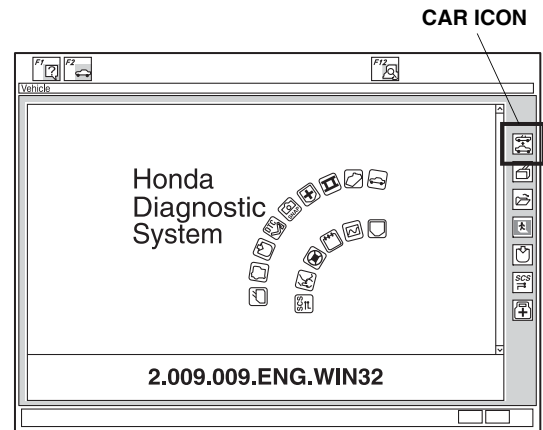

4. Input the VIN and other required information into the HDS, then click the check button.

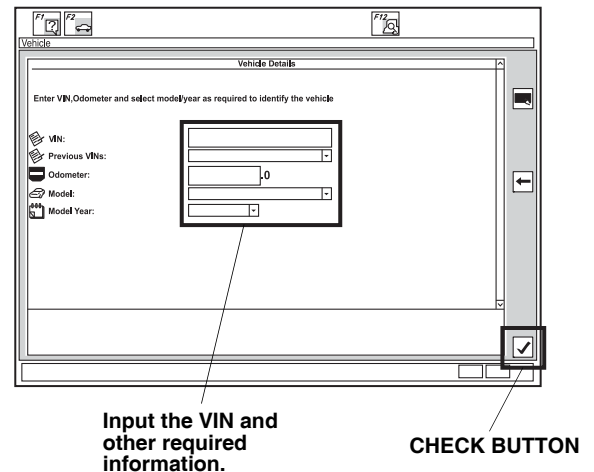

5. Select **Honda Systems**, then click the check button.

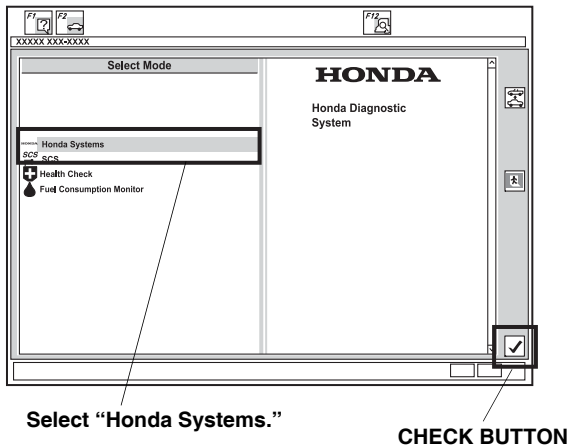

6. Select **R/C ENG STARTER** and click the check button.

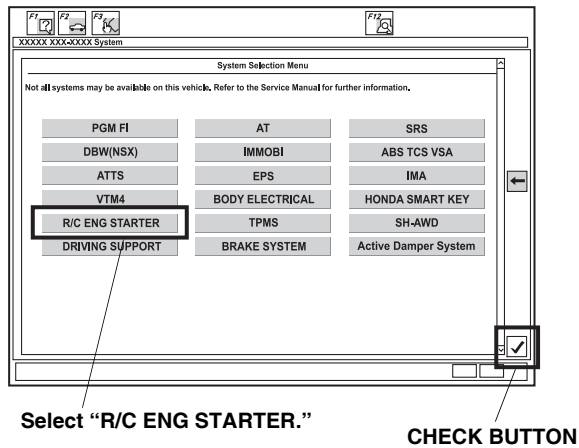

7. A **REMARKS** message will display. Click on the check button.

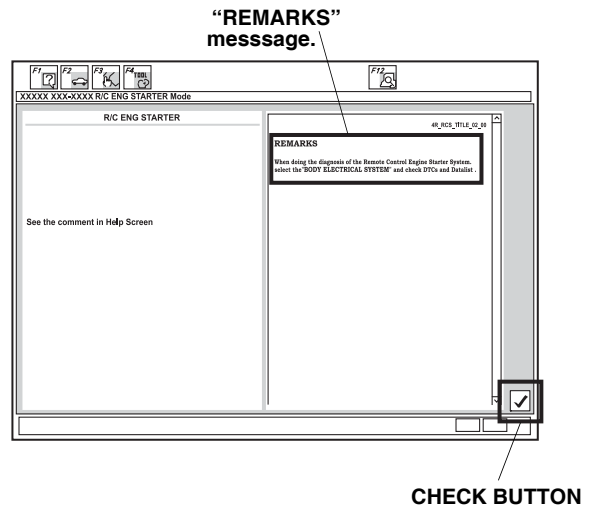

8. Select **REGISTER REMOTE CONTROL ENGINE STARTER UNIT**, then click the check button.

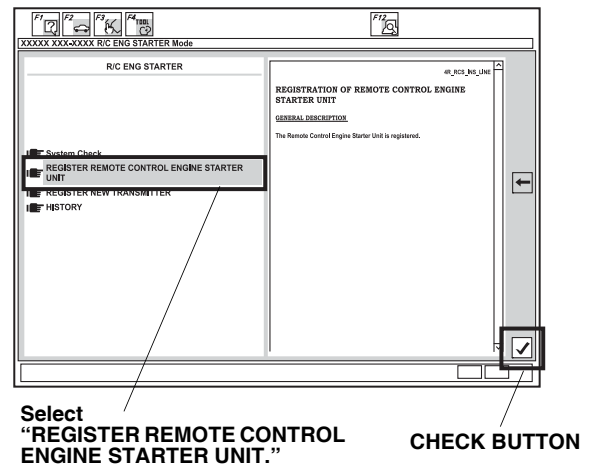

9. The following message will display: **Obtain PCM code (IMMOBILIZER PCM CODE) from iN. This vehicle's VIN will be required to obtain the password (USA).** Click on the check button.

“Obtain PCM-code” message.

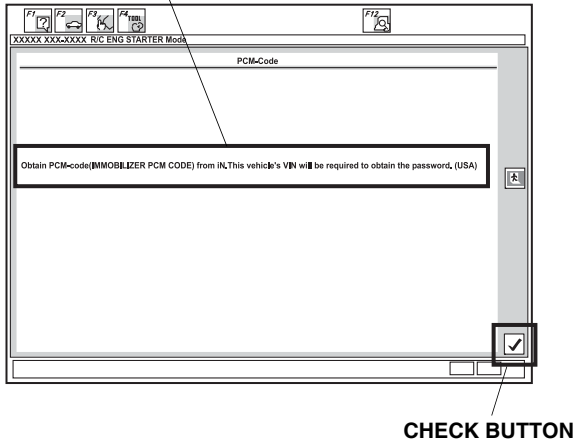

10. Input the PCM code, then click the check button.
NOTE: To ensure security, the PCM code (password) is changed everyday, so it is impossible to register the remote control engine starter if the dates of the PCM code acquisition and registration are different. The date of the HDS tester should also be the same.

Input the PCM Code.

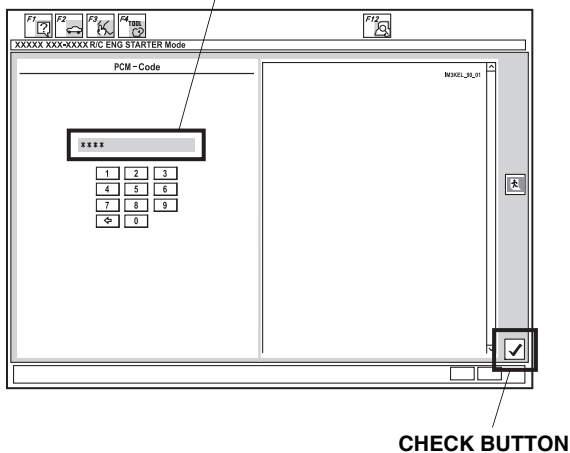

11. The following message will display: **The registration of the Remote Control Engine Starter Unit has been completed.** Click on the check button.

“The registration of the Remote Control Engine Starter Unit has been completed”.

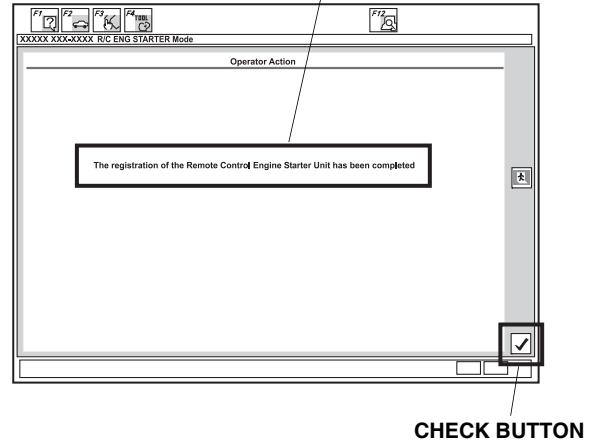

12. The following message will display: **Check that the engine can be started by the Transmitter.** Click on the check button.

“Check that the engine can be started by the Transmitter.”

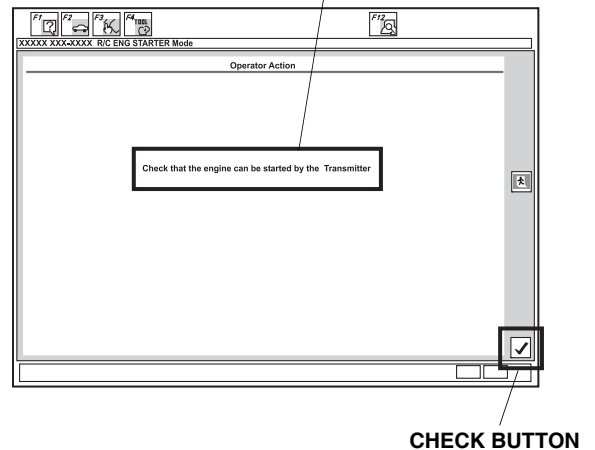

13. Perform the function test on page 22, then disconnect the HDS.

FUNCTION CHECK

Operating Conditions

- The hood is closed.
- The shift lever is in Park.
- The key is not in the ignition switch.
- All doors and tailgate are closed and locked.

Inspection

1. Within 1 second, press the command button and then the start button on the transmitter.
The engine should start if all operating conditions are met.

Does the engine start?

Yes - Operation is normal.

No:

- Make sure all Operating Conditions are met.
- Check the engine starter harness connections.
- Connect the HDS and check for an indicated failure.
(Refer to the appropriate service manual for details.)

2. Press the command button on the transmitter, and within 1 second, press the stop button. The engine should stop.

Does the engine stop?

Yes - Operation is normal.

No - Check the engine starter harness connections.

3. After the engine has stopped, start the engine again, and check that the engine stops after each of the following conditions:

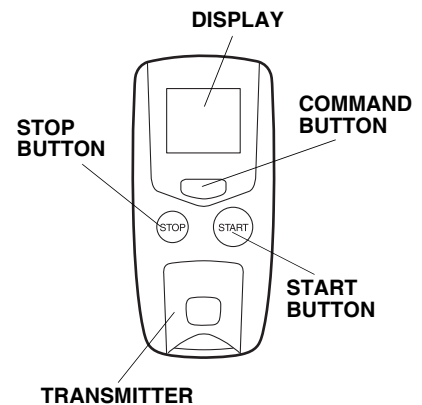

NOTE:

- Each test must be completed within 30 seconds after engine starts.
- After each test the ignition key must be cycled, or the driver's door must be opened and closed.
 - Move the shift lever out of the P position.
 - Unlock or open the doors or the trunk lid.
 - Open the hood.
 - Insert the key in the ignition.
 - Press on the brake pedal.

Does the engine stop after each of these tests?

Yes - Operation is normal.

No - Check the engine starter harness connections.

4. Check that the power window or the moonroof does not function when the engine is started with the transmitter.
5. Press the command button on the transmitter two times and check the vehicle condition on the display.
6. Check the operation of the transmitter when the vehicle is 100 m to 150 m (325 ft. to 490 ft.) away and when the vehicle is in direct sight.

How to Program an Additional Transmitter

1. Connect the HDS to the data link connector.
2. Start the HDS and click on the car icon.
3. Input the vehicle's VIN and other required information.
4. Select **Honda Systems**.
5. Select **R/C Engine Starter**.
6. Select **REGISTER NEW TRANSMITTER**.
7. When "Ready to program the new transmitter" shows, select **ENTER**.
8. Press and release the Command button.
9. Press and release the Stop button.
10. Perform the function check on both transmitters.

NOTE: Only 2 remotes can be stored in the system's memory.