 <b>HONDA</b> <b>INSTALLATION</b> <b>INSTRUCTIONS</b>	Accessory	Application	Publications No.
	TRUNK SPOILER	2000 ACCORD 4-DOOR	All 20550
			Issue Date JULY 1999

## PARTS LIST

Trunk spoiler

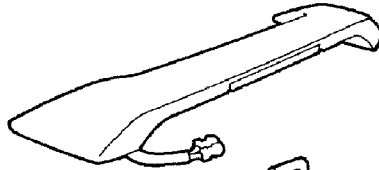

Right trunk spring  
(with bend)



Left trunk spring

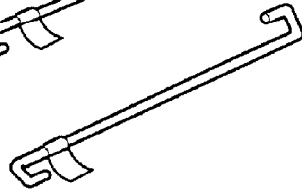

Template



Spoiler harness

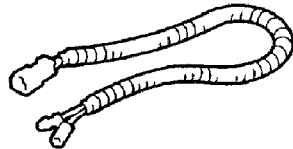

4 Clip bolts



4 Cap nuts



8 Long wire ties

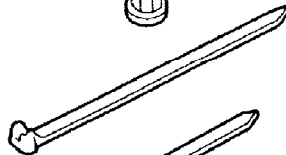

4 Short wire ties



2 Large protectors



## TOOLS AND SUPPLIES REQUIRED

Small flat-tip screwdriver  
 Eye protection (face shield, safety goggles, etc.)  
 Drill  
 3 mm, 6 mm, 8 mm, and 10 mm Drill bits  
 Drill stop  
 10 mm Combination wrench  
 Felt-tip pen  
 Center punch  
 File  
 Touch-up paint  
 Hammer  
 Piece of wire  
 10 mm Socket  
 Torque wrench  
 Diagonal cutters  
 Heavy gloves  
 Trunk Spring Installer/Remover:  
 (T/N 08M10-SM4-100)

## INSTALLATION

**Customer Information:** The information in this Installation Instruction is intended for use only by skilled technicians who have the proper tools, equipment, and training to correctly and safely add equipment to your car. These procedures should not be attempted by "do-it-yourselfers."

1. Make sure you have the anti-theft code for the radio, then write down the frequencies for the preset buttons.
2. Disconnect the negative cable from the battery.

3. Inside the trunk lid, locate the two identification holes on the trunk lid. Mark and lightly center-punch the center of the holes. Repeat on the other side.

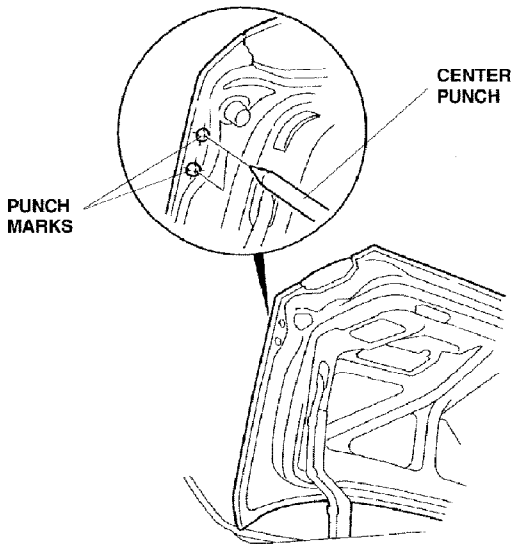

4. Have an assistant hold the trunk lid open. While wearing eye protection, drill an 8 mm hole through each mark:
  - First drill with a 3 mm bit, then a 6 mm bit, and finish with an 8 mm bit.
  - Remove all burrs and metal shavings, and apply touch-up paint to the edges of the holes.
  - Repeat on the other side.
  - When the touch-up paint is dry, clean the area to be covered, and wax it with a high-quality paste wax.

First drill pilot holes with 3 mm and 6 mm bits, then finish with an 8 mm bit.

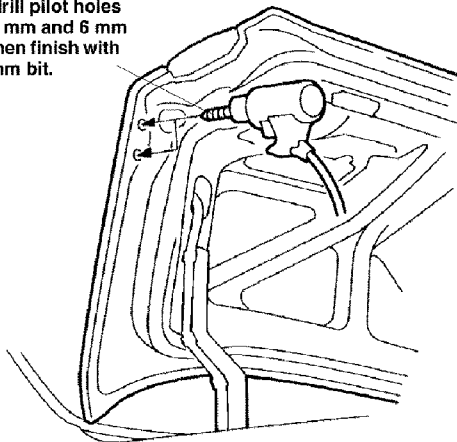

5. Close the trunk lid. Position the template, printed side up, at the left (driver's side) edge of the trunk lid. Align the two outer holes in the template with the two holes in the trunk lid. Using a felt-tip pen, mark the trunk lid as indicated on the template.

The right side of the trunk lid does not need a hole; mark only the left side for the spoiler harness.

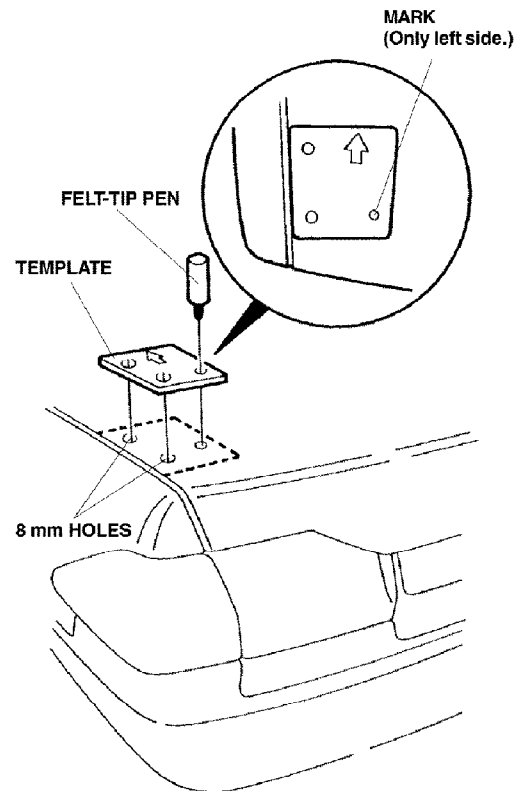

6. Remove the template, and lightly center-punch the mark.

7. While wearing eye protection, drill a 10 mm hole at the center-punched mark through the outer skin of the trunk lid; this hole is for routing the spoiler harness through the trunk lid. Use a drill stop to avoid drilling through the inner panel:

- First drill with a 3 mm bit, then with a 6 mm bit, next with an 8 mm bit, and finish with a 10 mm bit.
- Remove all burrs and metal shavings, and apply touch-up paint to the edge of the hole you drilled.

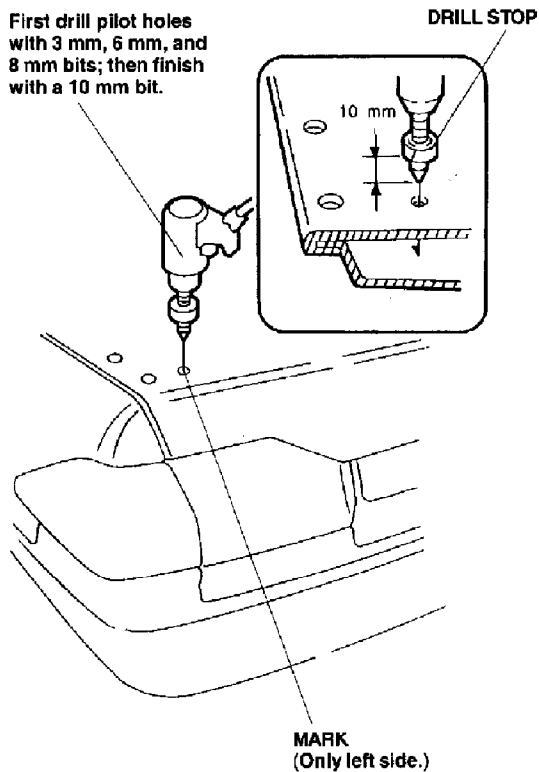

8. Remove and discard the packaging hardware (bolts, nuts, washers, and plates) that is attached to the bottom of the spoiler.

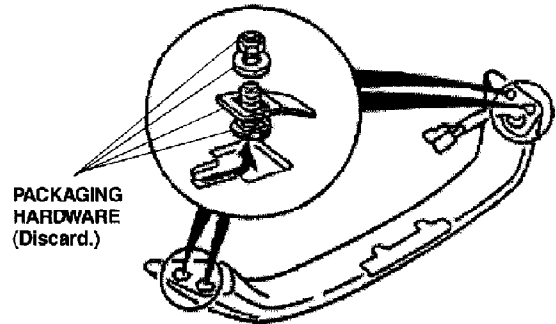

9. Install the four clip bolts supplied into the slots of the spoiler.

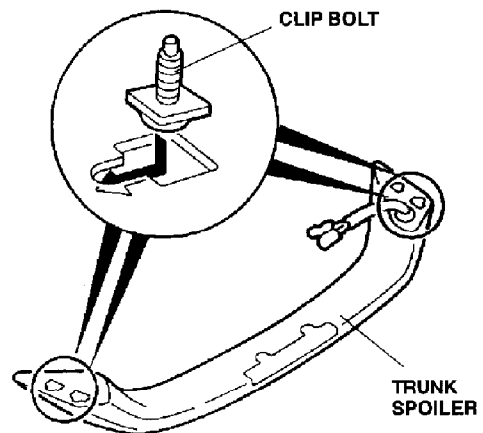

10. Hold the spoiler above the trunk lid, and route the spoiler harness down through the 10 mm hole you just drilled. Seat the rubber grommet into the 10 mm hole; then, route the spoiler harness through the rectangular hole as shown. If necessary, use a piece of wire to pull the spoiler harness.

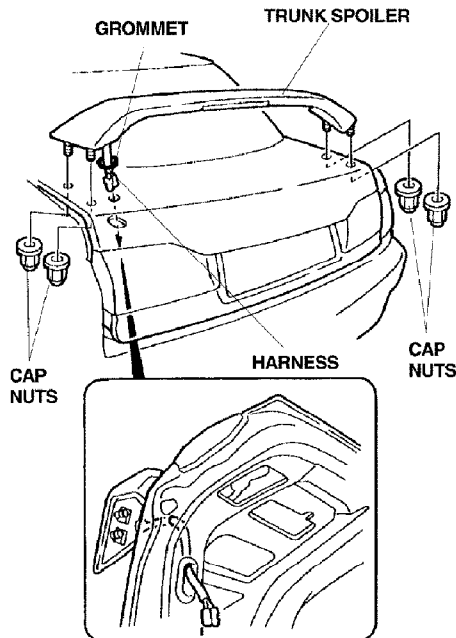

11. Fit the trunk spoiler into position on the trunk lid, and install the four cap nuts. Torque the cap nuts to 7 to 10 N•m (5 to 7 lb-ft).
12. With an assistant holding the trunk lid open, remove the old trunk springs from the trunk hinge arms using the special tool. Wear heavy gloves to protect your hands, and pull the special tool slowly and carefully toward you.

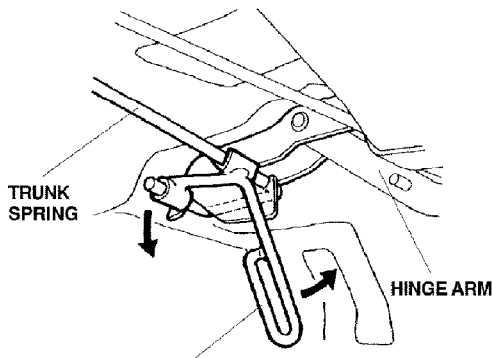

**TRUNK SPRING INSTALLER/REMOVER**  
(Sold Separately) T/N 08M10-SM4-100

13. Install the heavy-duty springs in the reverse order of removal:

- Set the tool on the unmarked end of each trunk spring.
- Install the straight spring in the hole in the trunk hinge on the right (passenger's) side of the vehicle; install the bent spring in the hole in the trunk hinge on the left (driver's) side.
- Wearing gloves, rotate the tool as you pull it toward you.
- Set the springs in the first notch (original position) of the hinge arms.
- Reinstall the center clip on the trunk springs.

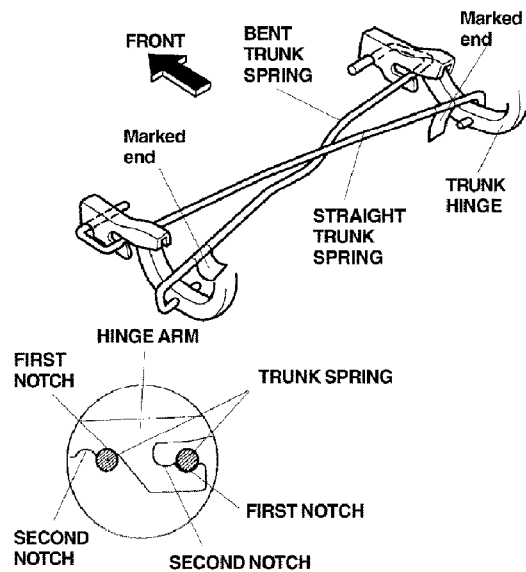

14. Inside the trunk lid, use diagonal cutters to cut the tabs off the backs of the protectors at both sides of the trunk lid; remove and discard the protectors. Install the new large protectors on both sides of the trunk lid.

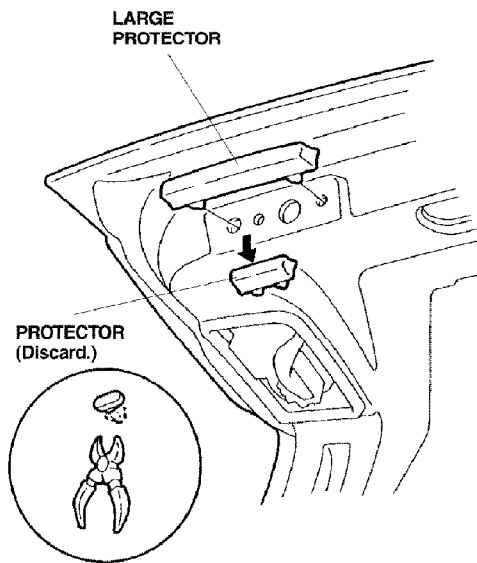

## Routing the Wire Harness

15. Unplug the 2-pin connector of the high-mount brake light, and connect it to the 2-pin connector of the spoiler harness.

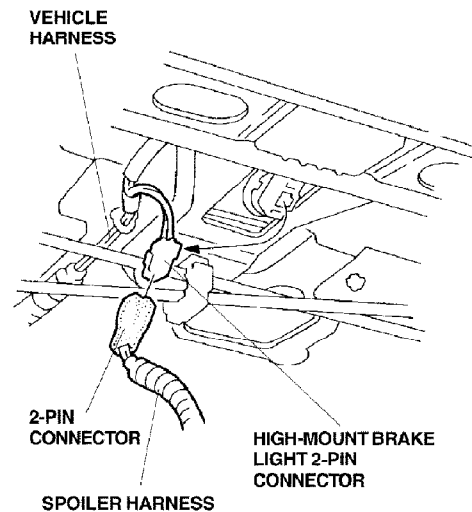

16. Inside the trunk, route the spoiler harness along the vehicle harness, and secure the spoiler harness to the vehicle harness with four long wire ties and two short wire ties in the areas shown.

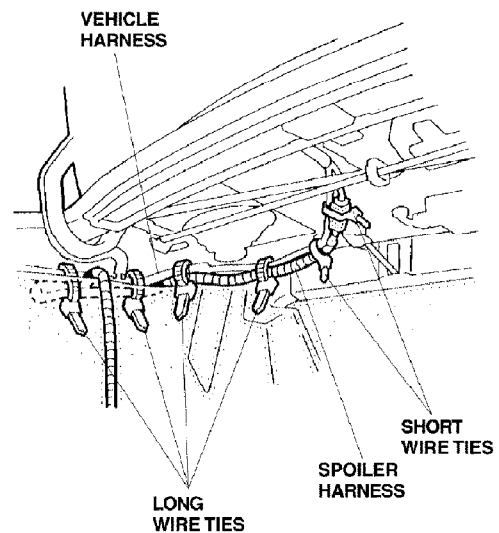

17. Connect the spoiler terminals to the spoiler harness terminals.

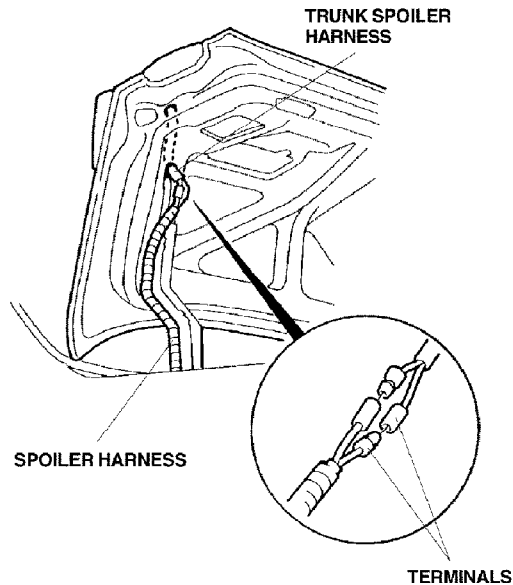

18. Route the spoiler harness along the vehicle harness secured to the trunk hinge arm. Secure the spoiler harness to the vehicle harness with six short wire ties in the areas shown, then tuck the spoiler terminals back in the hole in the trunk lid.

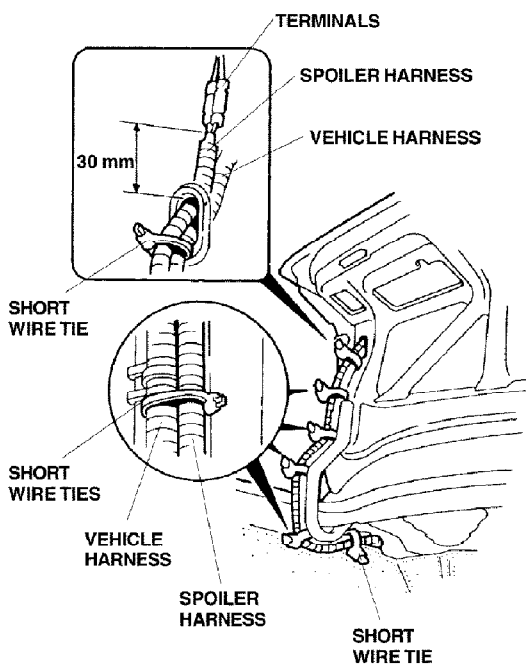

19. Check that all wire harnesses are routed properly and all connectors are plugged in.
20. Reconnect the negative cable to the battery.
21. Enter the customer's radio anti-theft code, and reset the radio station presets.
22. Reset the clock.
23. Check that the spoiler brake light comes on when the brake pedal is pressed.

## USE AND CARE

- Handle the spoiler with care. It is not designed to absorb impact.
- Check the spoiler mounting nuts periodically, and retighten them if necessary.