 HONDA INSTALLATION INSTRUCTIONS	Accessory	Application	Publications No.
	EMBLEM KIT	2000 ACCORD 2- AND 4-DOOR	AH 20502
			Issue Date
			JULY 1999

PARTS LIST

2-DOOR

Gold: P/N 08F20-S82-100
 Black Chrome: P/N 08F20-S82-100G

Front "H" emblem

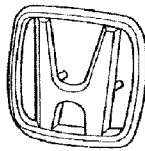

Rear "H" emblem

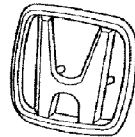

Rear "ACCORD" emblem

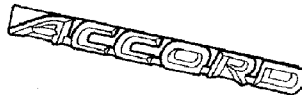

4-DOOR

Gold: P/N 08F20-S84-100
 Black Chrome: P/N 08F20-S84-100N

Front "H" emblem

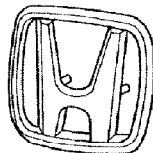

Rear "H" emblem

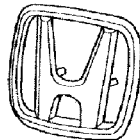

Rear "ACCORD" emblem

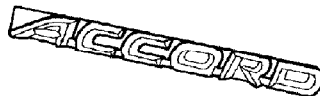

2 Push nuts



TOOLS AND SUPPLIES REQUIRED

- Phillips screwdriver
- Flat-tip screwdriver
- Diagonal cutters
- Contact cleaner
- Shop towel
- String
- Masking tape

INSTALLATION

NOTE:

- Be careful not to damage the body finish when you remove and install the emblems.
- The emblem kit should be installed only when the ambient air temperature is 60°F (15°C) or above.
- To allow the adhesive to cure, do not wash the vehicle for 24 hours.

Installing the Front "H" Emblem

2-DOOR:

1. Open the engine hood. Remove the front "H" emblem (two screws).

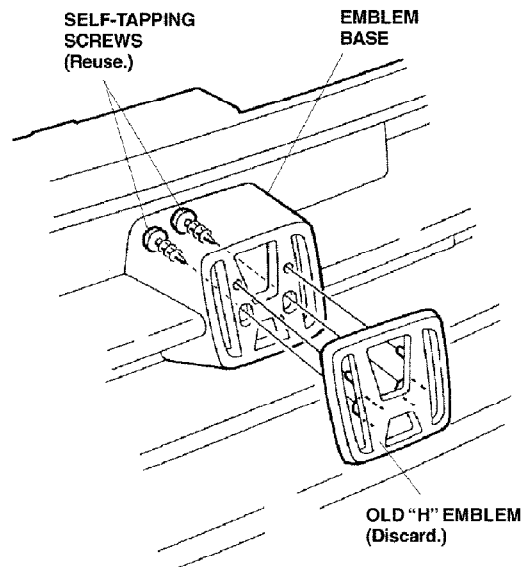

- Using a contact cleaner, clean the area where the emblem was removed.
- Install the new front "H" emblem using the two screws removed in step 1.

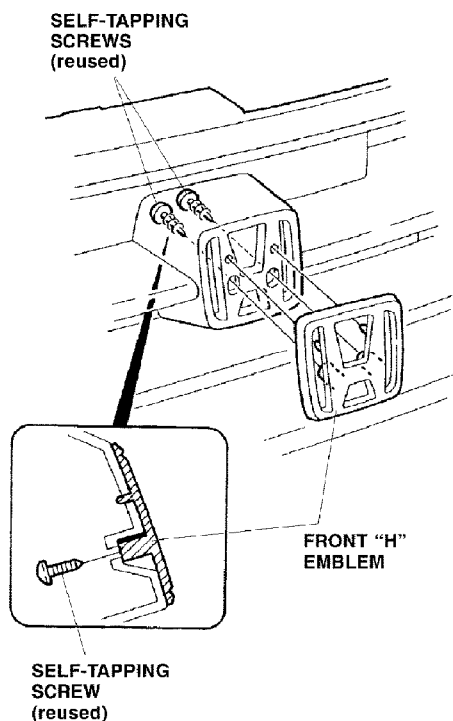

4-DOOR:

- Open the engine hood. Remove the emblem base (two screws).

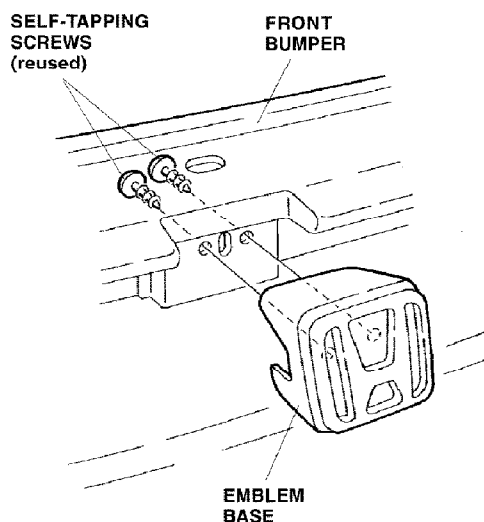

- Inside the emblem base, cut off the two pins, and remove the push nuts.

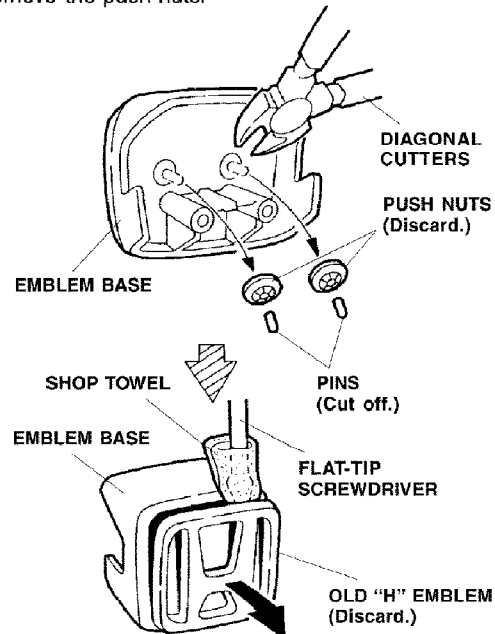

- Using a shop towel around a screwdriver, gently pry on the front "H" emblem to remove it. Remove and discard the emblem and the push nuts.
- Using a contact cleaner, clean the area where the emblem was removed.

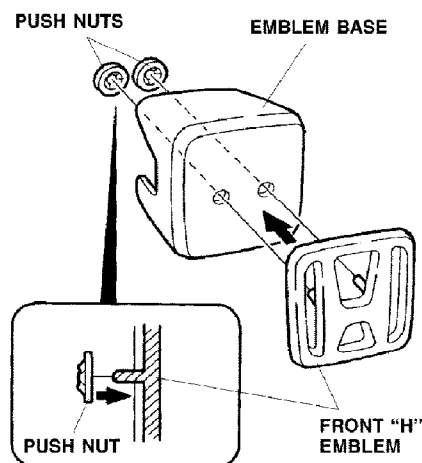

- Remove the adhesive backing from the new "H" emblem, and attach it to the emblem base. Slide the two new push nuts onto the pins.
- Reinstall the emblem base on the front bumper using the two screws removed in step 4.

Installing the Rear "H" and "ACCORD" Emblems

10. To prevent damage to the body finish, apply masking tape around the original rear "H" and "ACCORD" emblems.

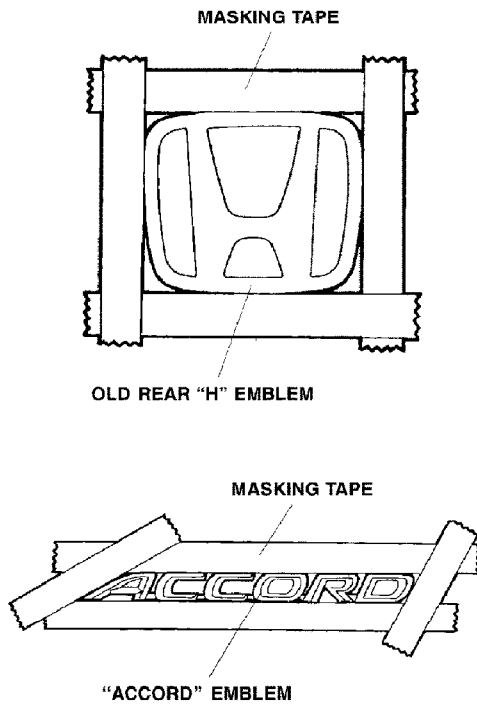

11. Remove the original emblems by cutting the outer edges with a piece of string.

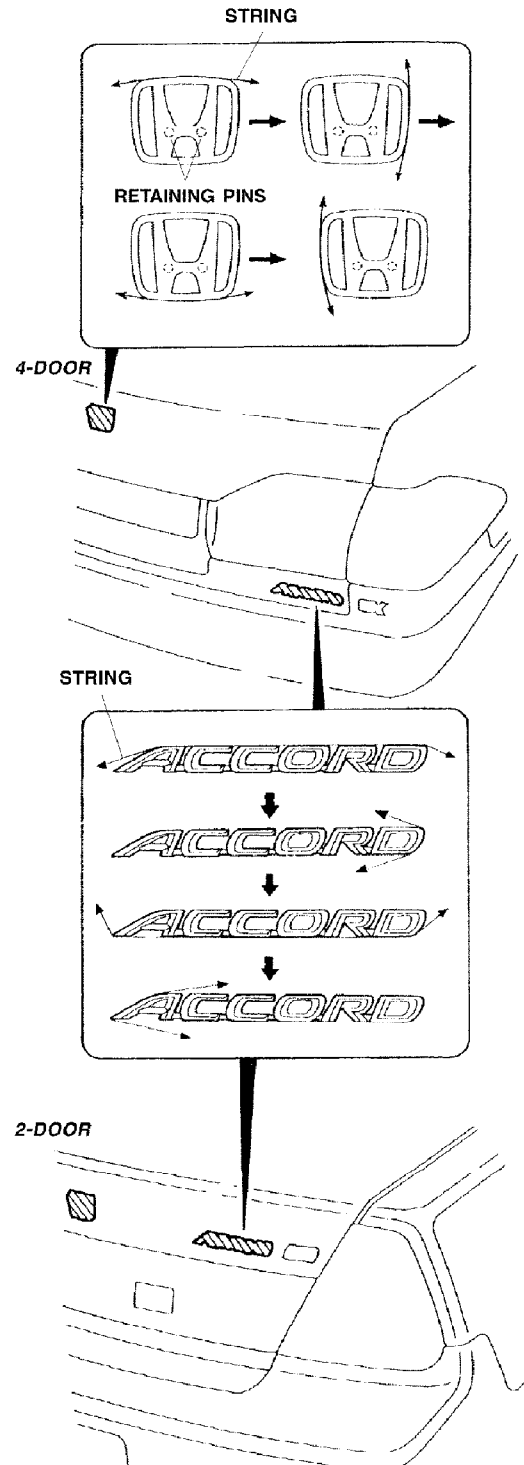

12. If any original clip(s) stayed in the body panel, make sure you remove and discard the same clip(s) on the new emblems.

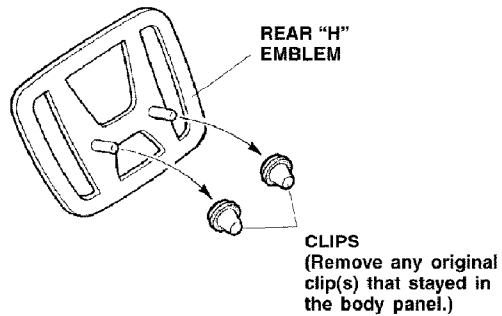

13. Using contact cleaner on a shop towel, clean the areas where the emblems were removed.
14. Remove the adhesive backing from the new rear "H" emblem, align the tabs on the emblem with the holes in the trunk lid, and attach the emblem to the trunk lid. Press the emblem firmly against the trunk lid with the palm of your hand.

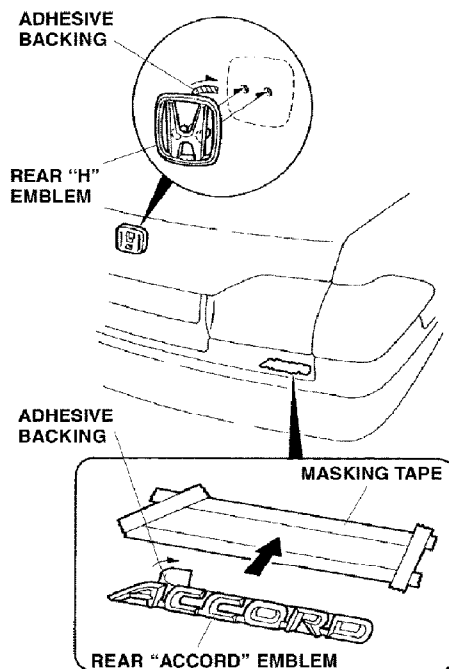

15. Remove the adhesive backing from the new rear "ACCORD" emblem, and attach it to the vehicle so it lines up with the tape. Press the emblem firmly against the trunk lid with the palm of your hand.

16. Remove the masking tape.

NOTE: After the emblem kit is installed, tell your customer not to wash the vehicle for 24 hours to give the adhesive time to cure.