 <b>HONDA</b> <b>INSTALLATION INSTRUCTIONS</b>	Accessory <b>TRUNK MOLDING</b> Chrome: P/N 08F21-S84-100F Gold: P/N 08F21-S84-100H	Application <b>2000 ACCORD 4-DOOR</b>	Publications No. <b>All 20548</b>
			Issue Date <b>JULY 1999</b>

## PARTS LIST

Trunk molding



2 Clips



## SUPPLIES REQUIRED

Contact cleaner

Shop towel

## INSTALLATION

### NOTE:

- Be careful not to damage the body finish while installing the trunk molding.
  - The trunk molding should be installed only when the ambient air temperature is 60°F (15°C) or above.
  - To allow the adhesive to cure, do not wash the vehicle for 24 hours.
1. Open the trunk lid. Using contact cleaner on a shop towel, thoroughly clean the rear edge of the trunk lid where the trunk molding will be installed.

2. Peel one inch of the adhesive backing from each end of the trunk molding, and fold it back.

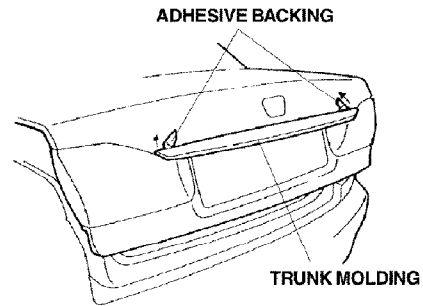

3. Center the trunk molding on the trunk lid, and temporarily install it by attaching both peeled ends to the trunk lid. Don't remove the remaining portion of the adhesive backing at this time.
4. Attach the molding to the trunk lid with the two clips. Insert the straight ends of the clips into the two slits in the molding and the curved ends onto the underside of the trunk lid.

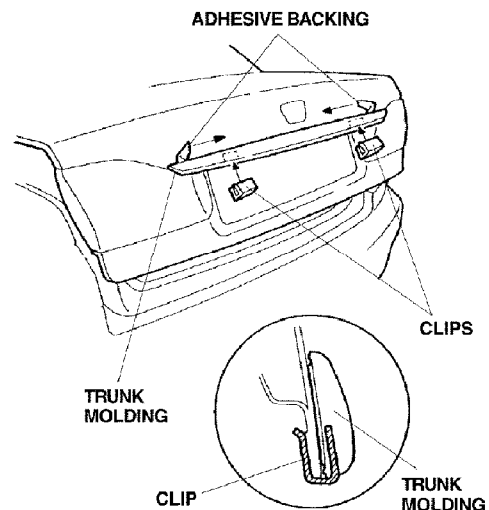

5. While holding light pressure against the molding, slowly and carefully remove the adhesive backing you peeled back in step 2.
6. Using the palm of your hand, firmly push the molding against the trunk lid in several places.