

INSTALLATION INSTRUCTIONS

Accessory KEYLESS ENTRY P/N: 08E60-S5D-100	Application CIVIC 2- AND 4-DOOR (HX, LX, GX)	Publications No. All 24178
		Issue Date AUG 2002

PARTS LIST

2 Transmitters

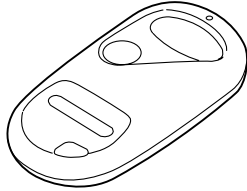

Keyless unit

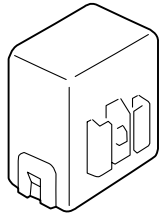

Keyless entry harness

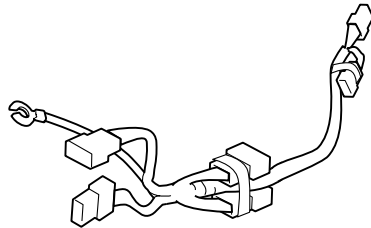

Fuse label

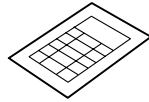

3 Wire ties

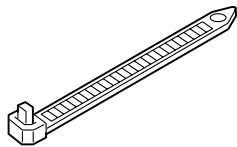

Owner's manual

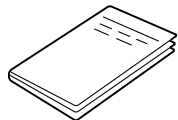

Ground bolt

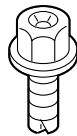

Cushion tape
(Not used)

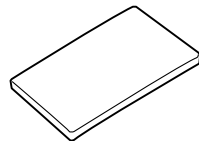

TOOLS AND SUPPLIES REQUIRED

- Phillips screwdriver
- Flat-tip screwdriver
- Ratchet
- 10 mm Socket
- Diagonal cutters

INSTALLATION

Customer Information: The information in this installation instruction is intended for use only by skilled technicians who have the proper tools, equipment, and training to correctly and safely add equipment to your car. These procedures should not be attempted by "do-it-yourselfers."

1. Write down the frequencies for the radio station preset buttons.
2. Disconnect the negative cable from the battery.
3. Remove the dashboard lower cover on the driver's side of the vehicle. Turn the two knobs counterclockwise and release the four retaining tabs.

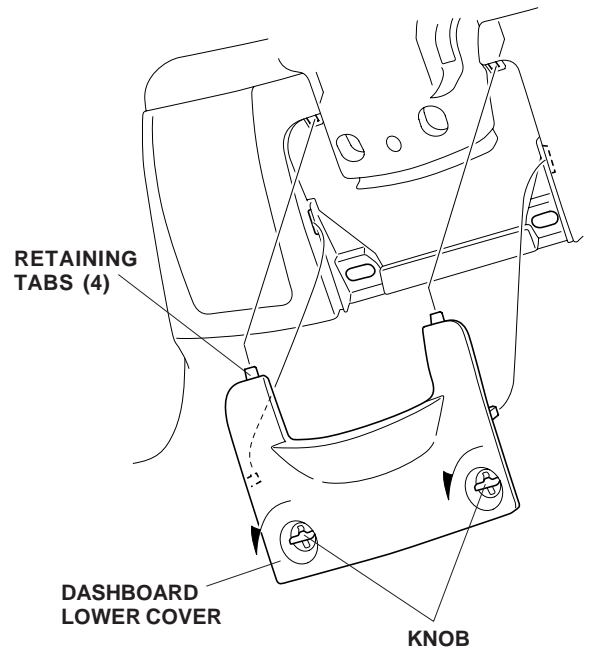

- Remove the driver's dashboard under cover. Turn the knob counterclockwise, and release the two clips and one retaining tab.

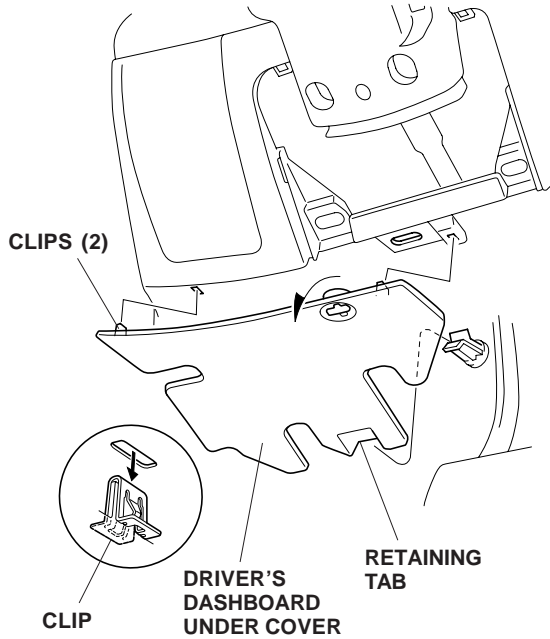

**Steps 5 thru 7:
Model equipped with console without armrest only**

- Pull up on the parking brake lever, then remove the console box (nine clips).

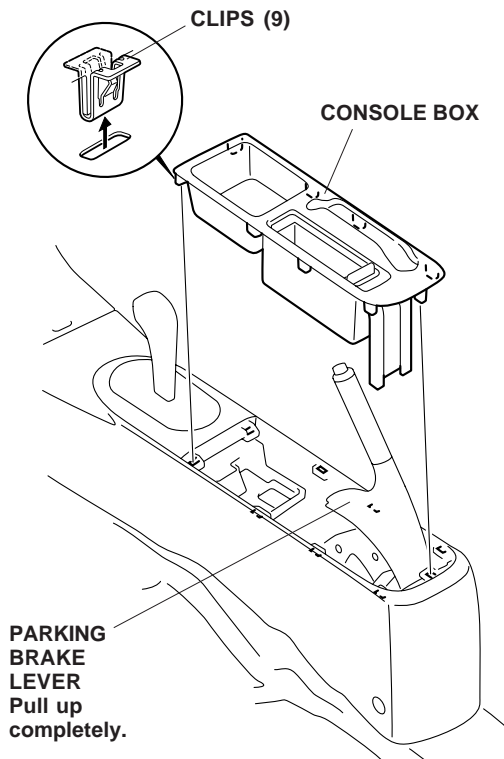

- Remove the two self-tapping screws, two screws and two clips fastening the center console, and remove the console:

- Place the shift lever in the Neutral position.
- On the M/T model, remove the shift knob from the lever by pulling the plastic section above the boot down firmly with one hand and turning the knob in a counterclockwise direction.
- If equipped with an optional armrest, remove the console after reclining the seat-back.

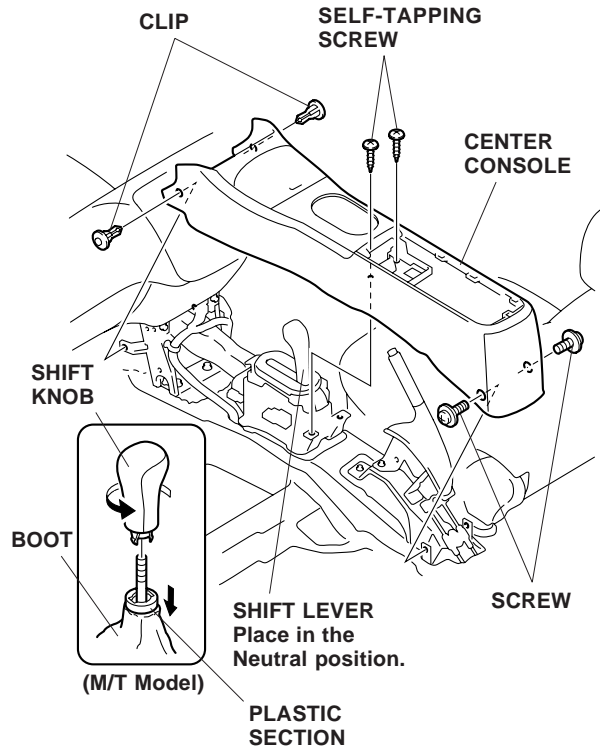

7. Remove the dashboard center lower cover:
 - With the parking brake applied, place the gear shift lever in the Neutral position.
 - Gently pry out on the lower cover to release the six retaining clips.
 - Unplug the accessory socket connector, and remove the lower cover. If equipped, unplug the fog light harness.

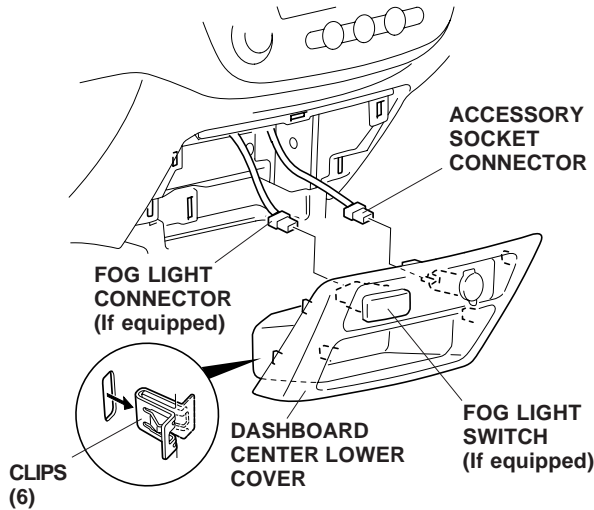

**Steps 8 thru 10:
Model equipped with console with armrest only**

8. Pry up on the four retaining tabs and remove the escutcheon.
9. Pry up on the three clips and six retaining tabs and remove the center console trim.
 - On the M/T model, remove the shift knob from the lever by pulling the plastic section above the boot down firmly with one hand and turning the knob in a counterclockwise direction.

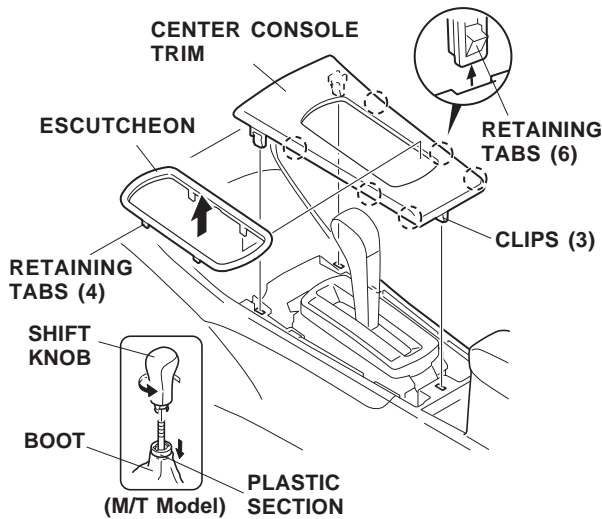

10. Remove the center lower trim:
 - With the parking brake applied, place the gear shift lever in the Neutral position.
 - Remove the two self-tapping screws fastening the lower trim.
 - Gently pry out on the lower trim to release the nine clips and the one retaining tab.
 - Unplug the accessory socket connector, and remove the lower trim.

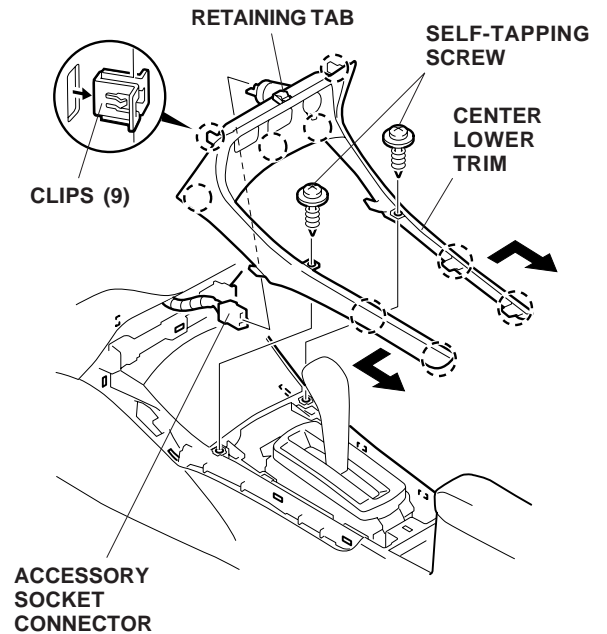

- Route the keyless entry harness behind the dashboard on the driver's side of the vehicle.

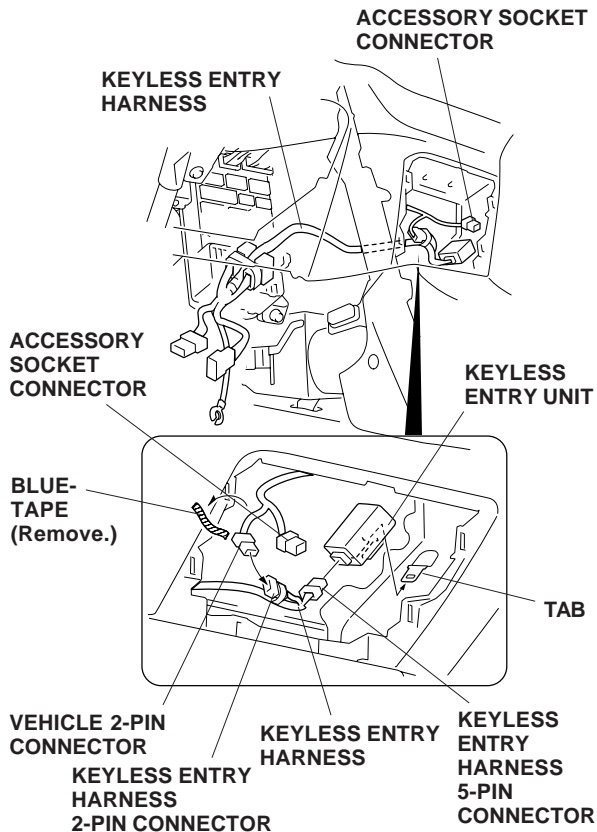

- Plug the keyless entry harness 5-pin connector into the keyless entry unit, then attach the keyless entry unit to the tab on the center console frame.
- Locate the 2-pin connector blue-taped to the vehicle accessory socket harness and remove the blue-tape to free the connector. Plug the 2-pin connector into the keyless harness 2-pin connector.
- Remove the two bolts fastening the fuse box, and the fuse box bracket, then slide the fuse box down.

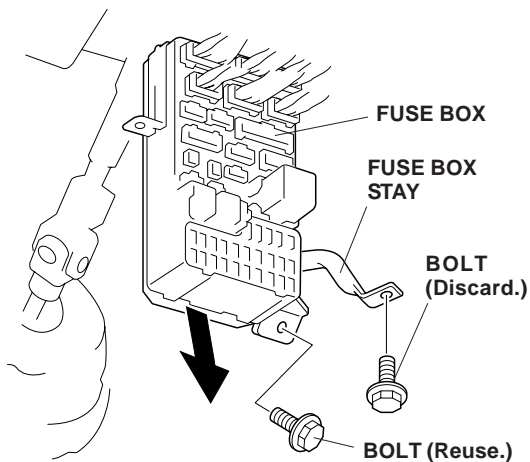

- Unplug the 10-pin connector from the fuse box, and plug the keyless entry harness 10-pin connector into the fuse box. Plug the vehicle 10-pin connector into the remaining keyless entry harness 10-pin connector.

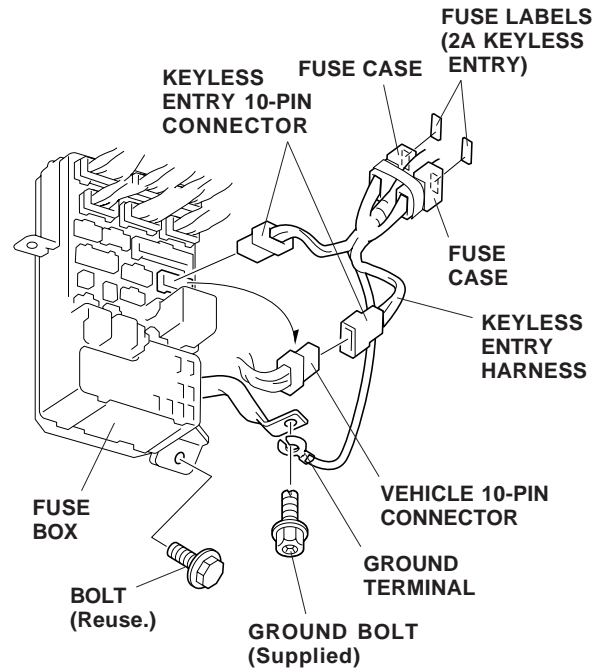

- Attach the two fuse labels (2A KEYLESS ENTRY) to the fuse cases on the keyless entry harness.
- Attach the ground terminal of the keyless entry harness to the fuse box bracket with the ground bolt provided.
- Reinstall the fuse box. Be careful not to pinch any harnesses.

19. Secure the keyless entry harness to the vehicle harness with three wire ties in the areas shown.

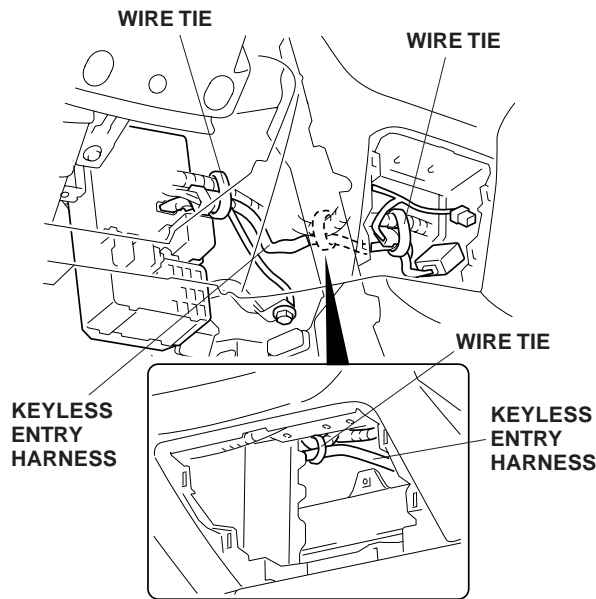

20. Check that all wire harnesses are routed properly and all connectors are plugged in.
21. Reinstall the all removed the parts.
22. Reconnect the negative cable to the battery, and reset the radio station presets.
23. Check the operation of the keyless entry system as described in the Owner's Manual supplied.

NOTE: Whenever the battery is disconnected, the driver's window AUTO function is disabled.

24. Start the engine. Push down on the driver's window switch until the window is fully open.
25. Pull up on the driver's window switch to close the window completely, then hold the switch for 2 seconds.
26. Lower and raise the driver's window to check operation of the driver's window AUTO function.

27. Do the ECM/PCM idle learn procedure.

- Make sure all electrical items are turned off.
- Start the engine. Hold the engine speed at 3,000 rpm with no load (in Park or Neutral) until the radiator fan comes on.
- Let the engine idle for about 5 minutes with the throttle fully closed and with all electrical items off.

NOTE: If the radiator fan comes on during this step, the time it is operating must not be included in the 5 minutes.