



# INSTALLATION INSTRUCTIONS

Accessory

**CD CHANGER ATTACHMENT KIT**

Application

**CIVIC HYBRID**

Publications No.

**All 23685**

Issue Date

**APRIL 2002**

## PARTS LIST

**CD Changer Attachment Kit  
P/N 08B26-S5B-100**

CD changer bracket

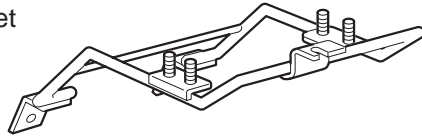

2 Side brackets



Clip nut



Washer-bolt, 6 x 16 mm



20 Wire ties

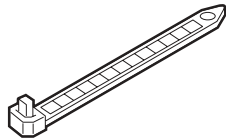

4 Flange nuts, 6 mm



EPT sealer

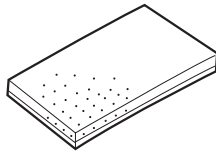

BUS cable

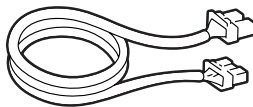

4 Washer-screws, 4 x 8 mm



**CD Changer  
P/N 08A26-1B1-100**

CD changer

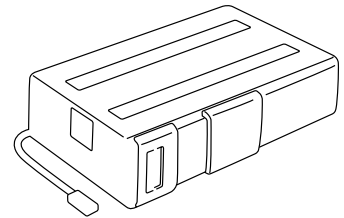

Owner's Manual

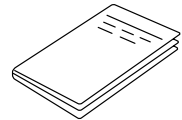

CD magazine

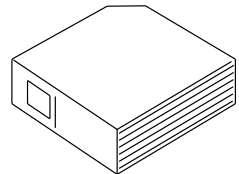

4 Washer-screws, 4 x 6 mm  
(Not used)



Adhesive seal sheet

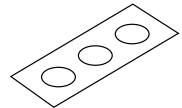

Locking covers

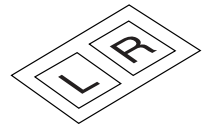

## TOOLS REQUIRED

Phillips screwdriver  
Flat-tip screwdriver  
Stubby Phillips screwdriver  
10 mm Combination wrench  
Clip remover  
8 mm and 10 mm Sockets  
Ratchet  
Small flat-tip screwdriver  
Utility knife  
Shop towel  
Isopropyl alcohol

### **Illustration of the CD Changer Installed on the Vehicle**

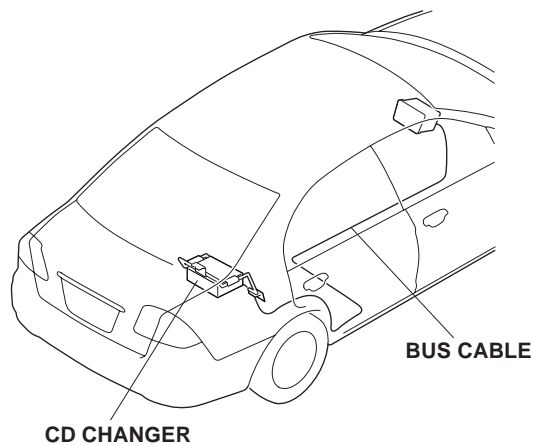

## INSTALLATION

**Customer information:** The information in this installation instruction is intended for use only by skilled technicians who have the proper tools, equipment, and training to correctly and safely add equipment to your car. These procedures should not be attempted by "do-it-yourselfers."

1. Make sure you have the anti-theft code for the radio, then write down the frequencies for the preset buttons.
2. Disconnect the negative cable from the battery.

3. Open the trunk lid, remove the trunk floor mat and trunk floor board.

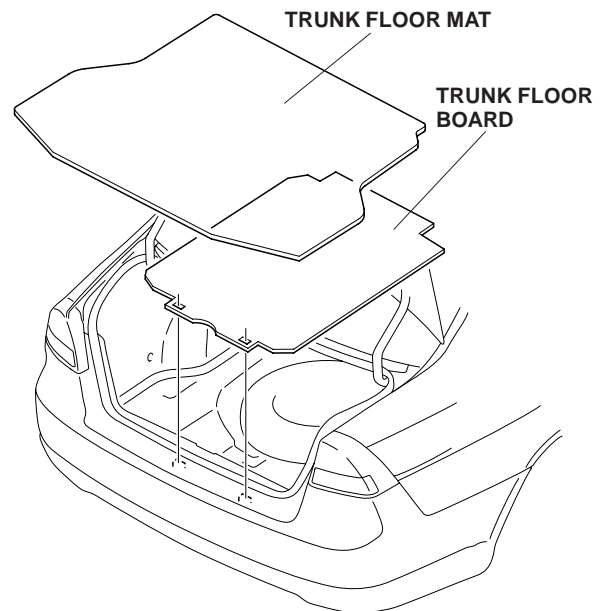

4. Remove the weatherstrip from the edge of the trunk opening in the area shown.

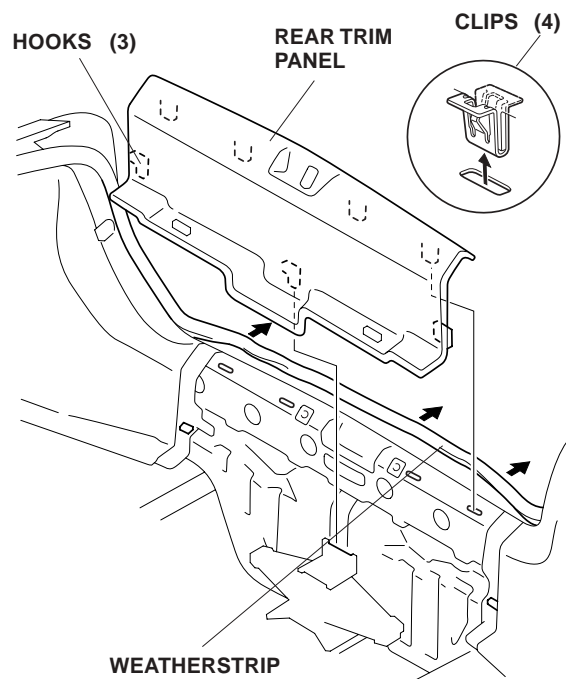

5. Remove the rear trim panel by removing the four clips and releasing the three hooks.

- Continue removing the weatherstrip in the area shown, and remove the three clips, then pull out on the right trunk side trim panel in the direction shown.

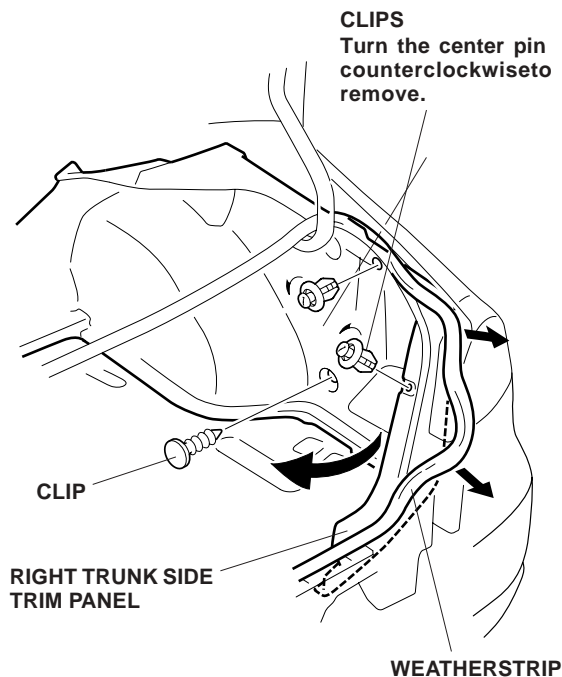

- Remove the five clips securing the trunk front trim panel. Take care not to damage the clips.

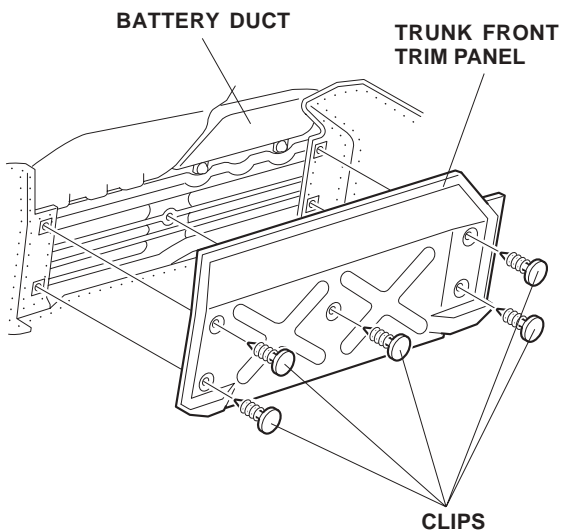

- Inside the passenger's compartment, remove the rear seat cushion by removing the bolt and releasing the two hooks.

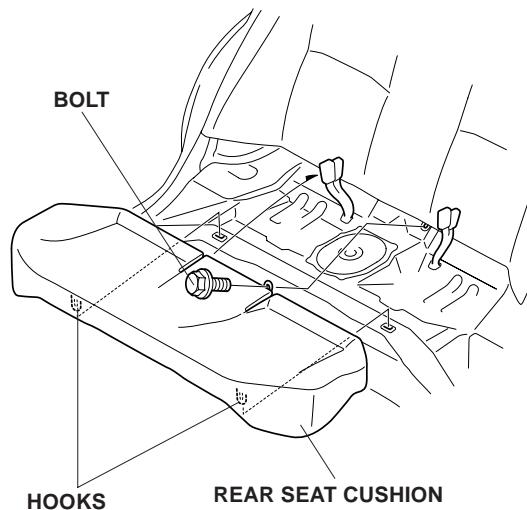

- Remove the two bolts that fasten the rear seat-back and pull the rear seat-back up to release the three hooks. Remove the rear seat-back.

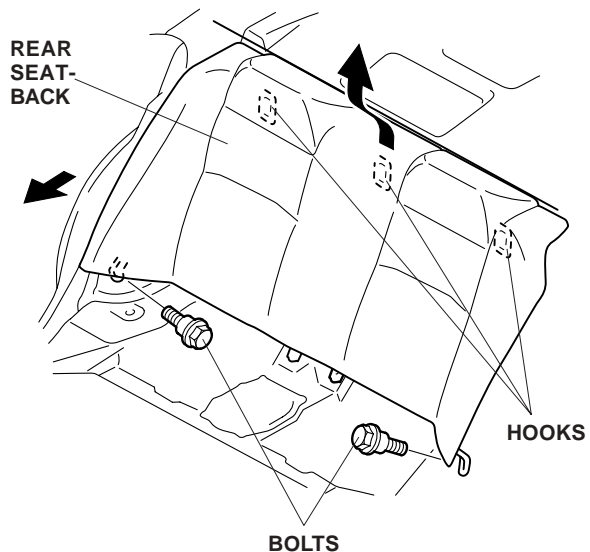

10. Pry up on the six retaining tabs, and remove the B-pillar lower trim panel.

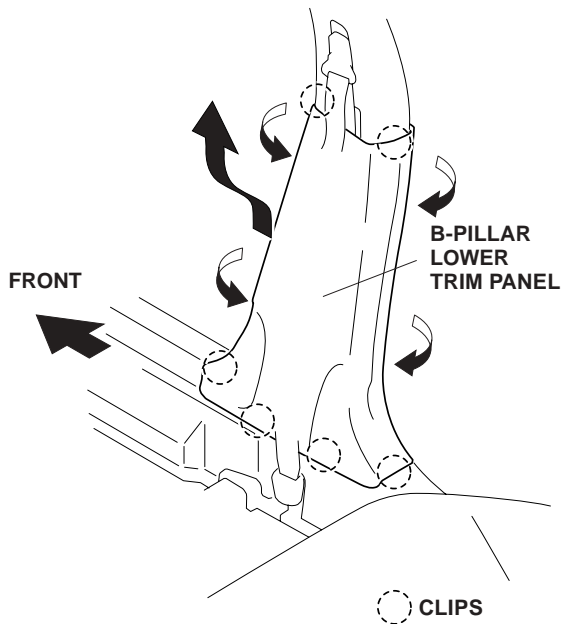

11. Remove the four clips, release the two retaining tabs that fasten the right seat side trim, and remove the trim. Take care not to damage the clips.

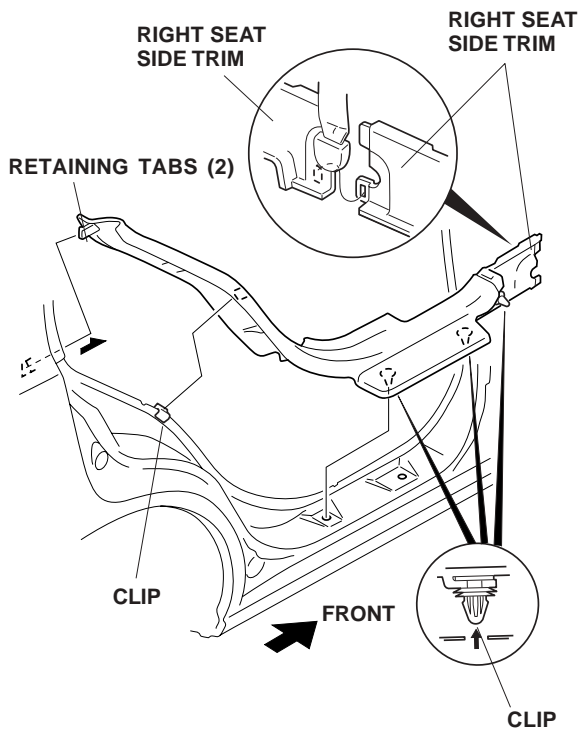

12. Pull up on the parking brake lever, then remove the console box (nine clips).

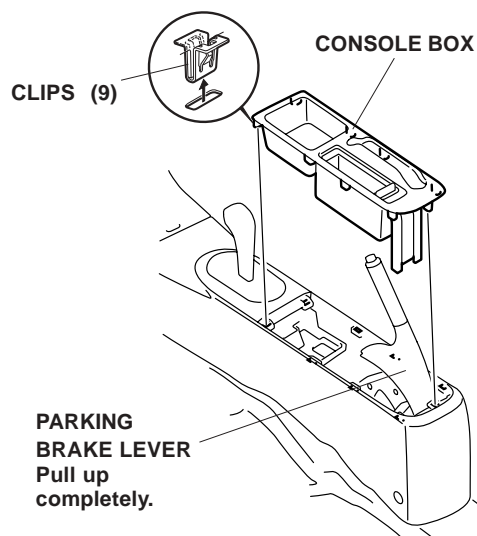

13. Remove the two self-tapping screws, two screws and two clips that fasten the center console and remove the console:

- Place the shift lever in the Neutral position.
- On M/T model, remove the shift knob from the lever by pulling the plastic section above the boot down firmly with one hand and turning the knob in a counterclockwise direction.
- If equipped with an optional armrest, remove the console after reclining the seat-back.

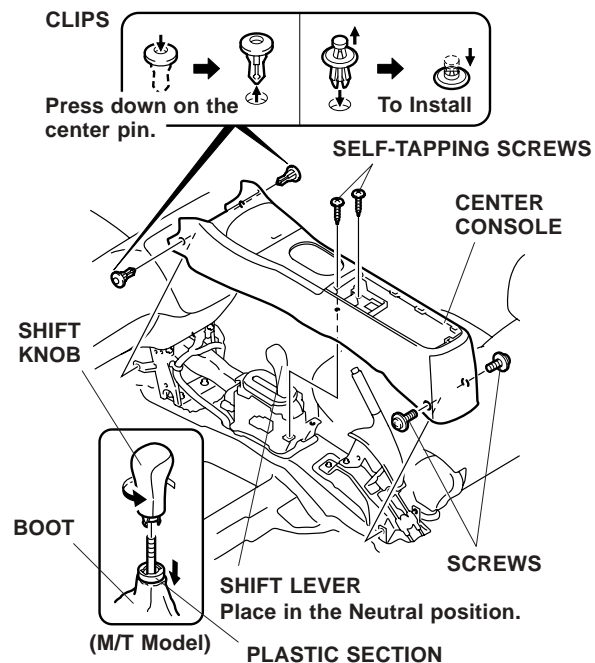

14. Remove the dashboard center lower cover.

**Without a Cigarette Lighter and Ashtray:**

- With the parking brake applied, place the gear shift lever in the Neutral position.
- Gently pry out on the lower cover to release the six retaining clips.
- Unplug the accessory power socket connector, and remove the lower cover.

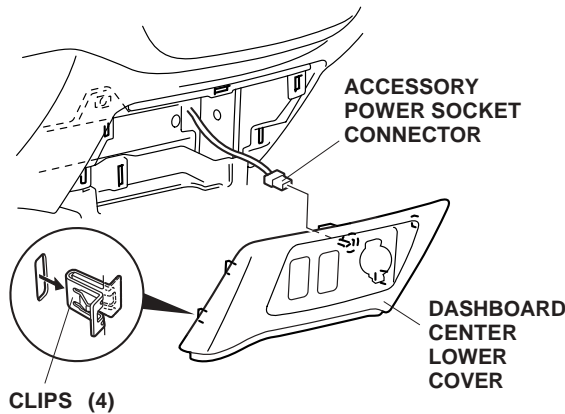

**With a Cigarette Lighter and Ashtray:**

- With the parking brake applied, place the gear shift lever in the Neutral position.
- Remove the ashtray.
- Inside the ashtray opening, remove the one self-tapping screw securing the dashboard center lower cover.
- Gently pry out on the lower cover to release the five retaining clips.
- Unplug the cigarette lighter harness, and illumination bulb, then remove the lower cover.

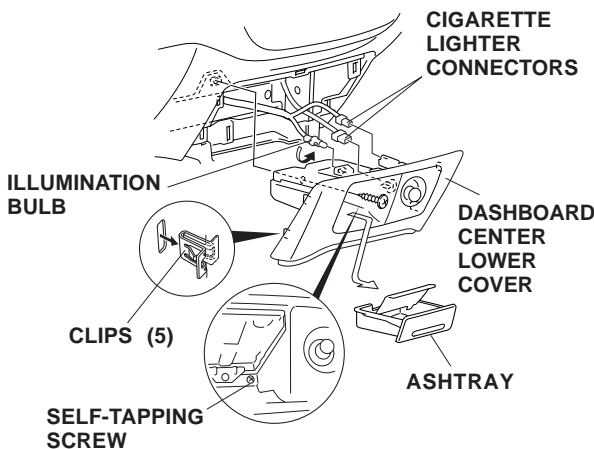

15. Remove the center panel:

- Remove the two bolts from the bottom of the center panel.
- Reach through the bottom opening, and push out on center panel bracket to release the nine retaining clips.
- Unplug the five connectors and the antenna lead, then remove the center panel.

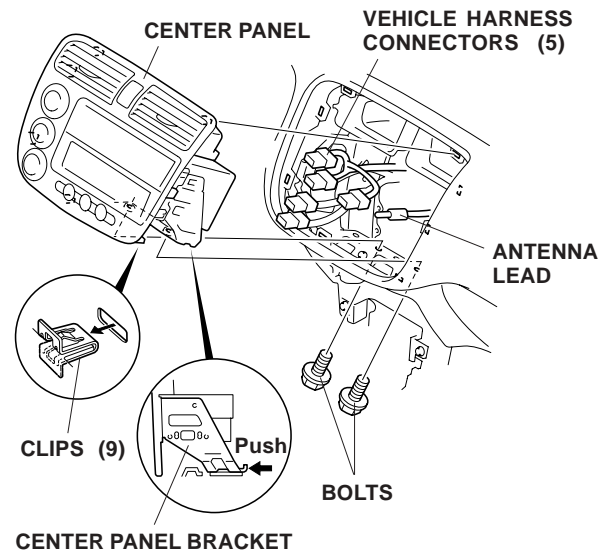

**Installing the CD Changer**

16. Carefully unpack the CD changer. Remove the three shipping clips, and discard the shipping cover. Save the shipping clips for your customer in the event the unit needs to be serviced.
17. Install an adhesive seal (included in the CD Changer) over each of the three shipping clip holes.

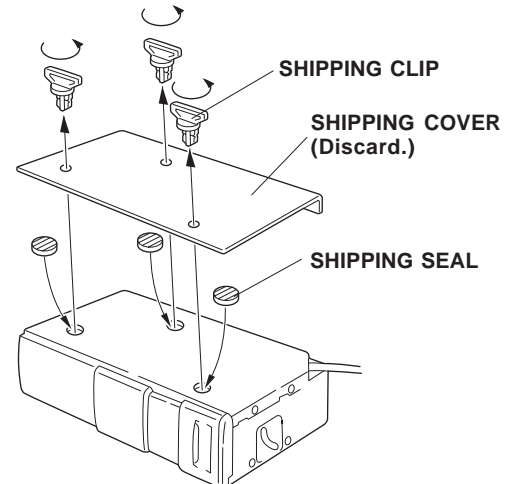

18. Visually check the position of the spring adjusting pins on both sides of the CD changer. If both of the spring adjusting pins are not in the horizontal (H) position, move the pins to the horizontal position with a small flat-tip screwdriver.

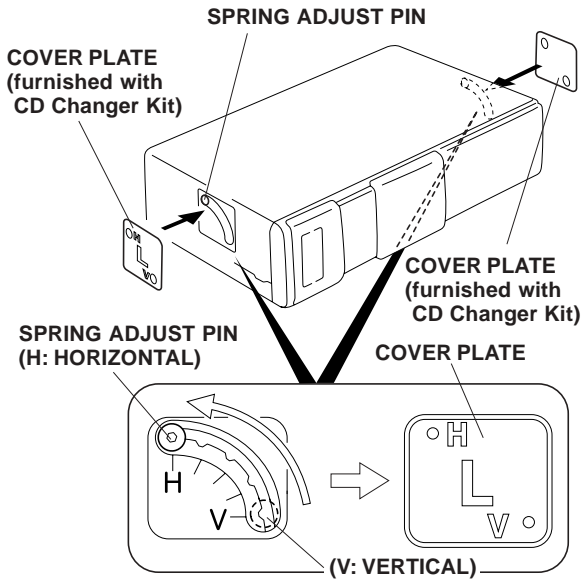

19. Remove the adhesive backings from the “L” and “R” locking covers, and attach them to the side of the CD changer. Align the two diagonally opposite holes with the H and V positions.
20. Install the side brackets to the CD changer using two 4 x 8 mm washer-screws for each side.

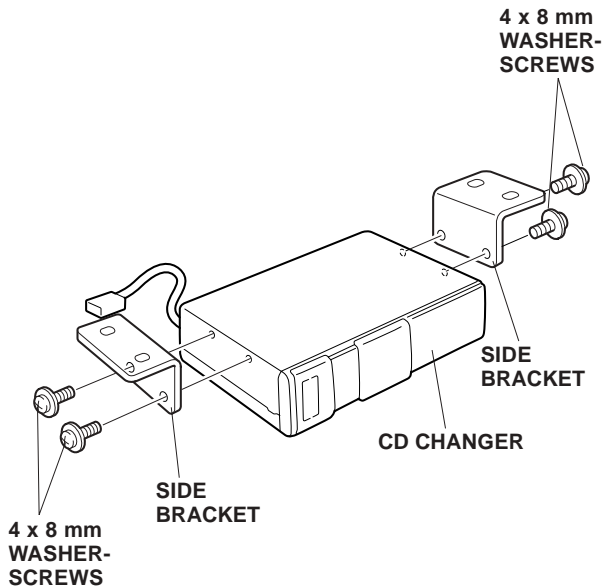

21. Position the CD changer (with the side brackets installed in step 20) on the CD changer bracket and install a 6 mm flange nut on each of the four studs as shown.

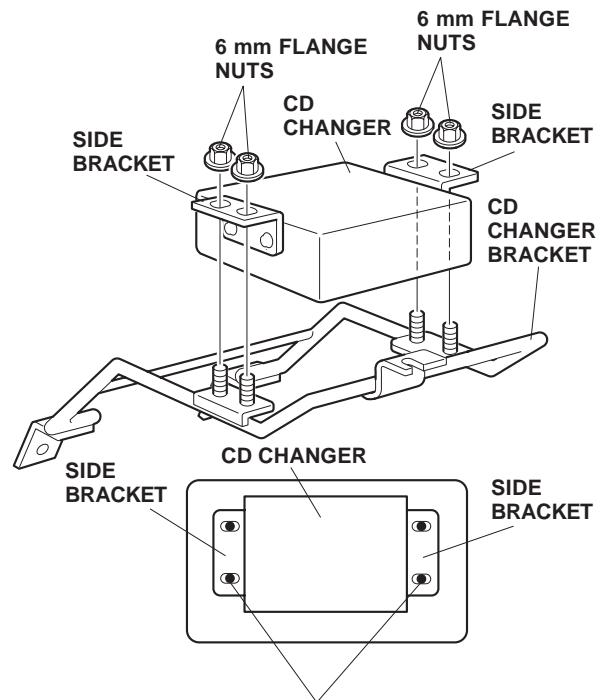

Check that the studs are positioned at the same location in the elongated holes in the CD changer side brackets.

22. Slide the clip nut onto the rear shelf through the hole in the shelf.

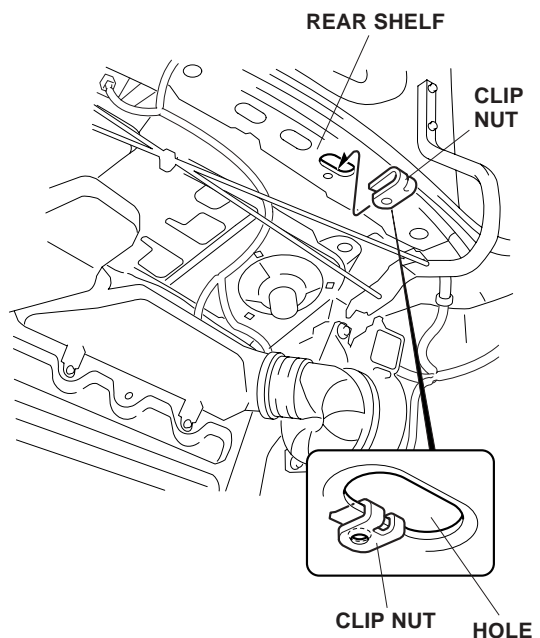

23. Remove the two bolts from the battery duct.

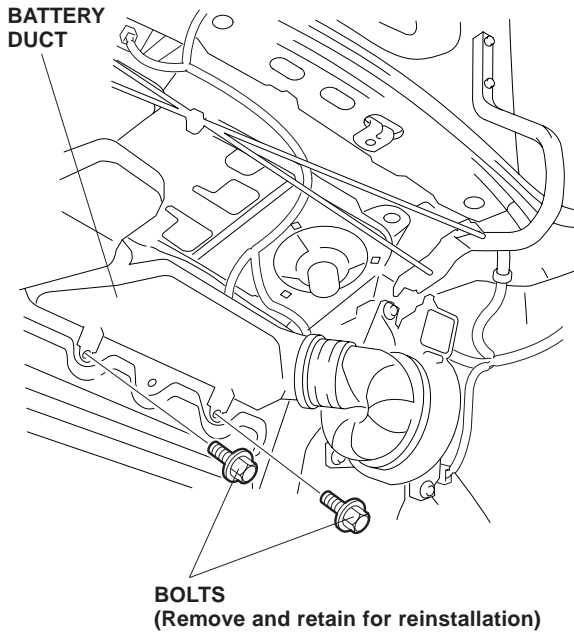

24. Position the CD changer bracket on the clip nut and battery duct and install the two bolts you just removed and one 6 x 16 mm washer-bolt furnished with CD changer attachment kit.

- Do not tighten the two bolts yet.

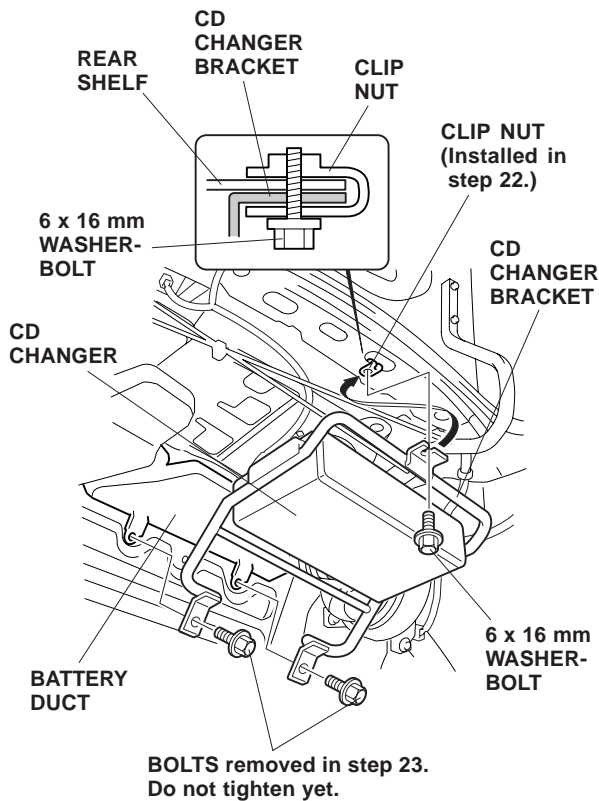

## Routing the BUS Cable

25. Plug the BUS cord connector into the connector from the CD changer.

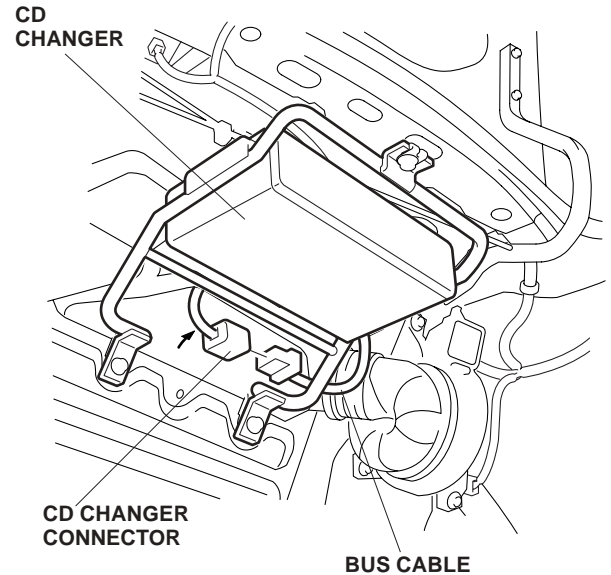

26. Secure the CD changer BUS cord, connectors and BUS cord to the CD changer bracket with the two wire ties in the areas shown.

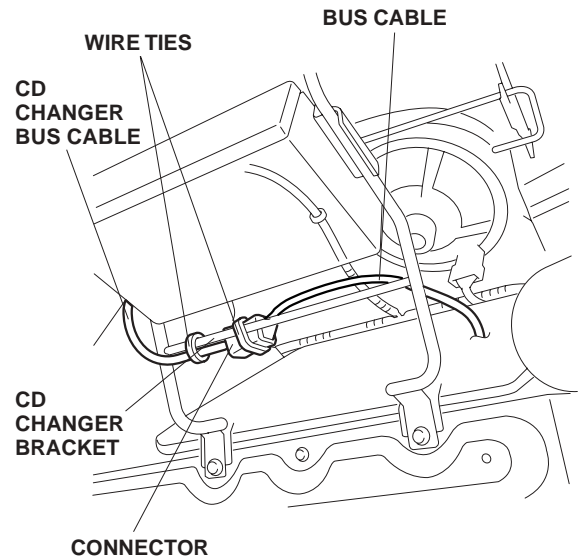

27. Inside the trunk, route the BUS cable over the IPC fan duct and into the cabin through the panel hole.

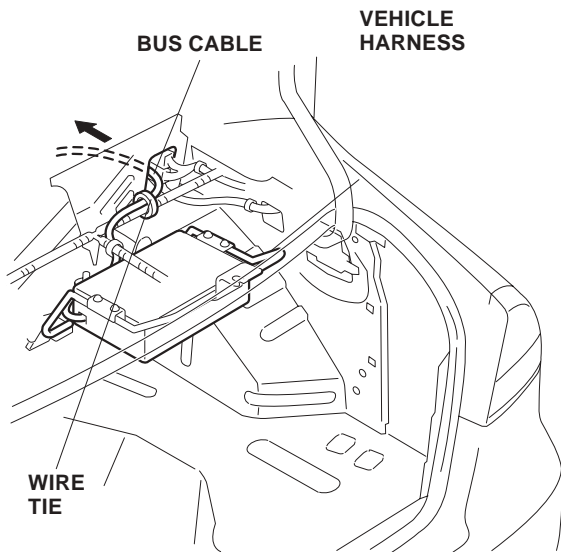

28. Secure the BUS cable to the vehicle harness with one wire tie.
29. Remove the one clip that secures the floor carpet and turn the carpet over in the direction shown. Route the BUS cable under the floor carpet, then secure the cable to the vehicle harness with the five wire ties in the areas shown.

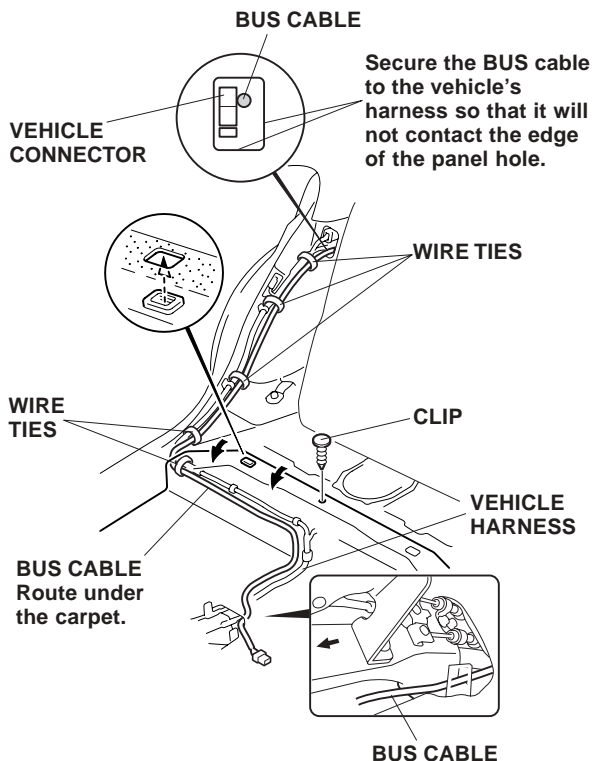

30. Route the BUS cable forward under the parking brake lever base and to the right front console frame along the vehicle harness.

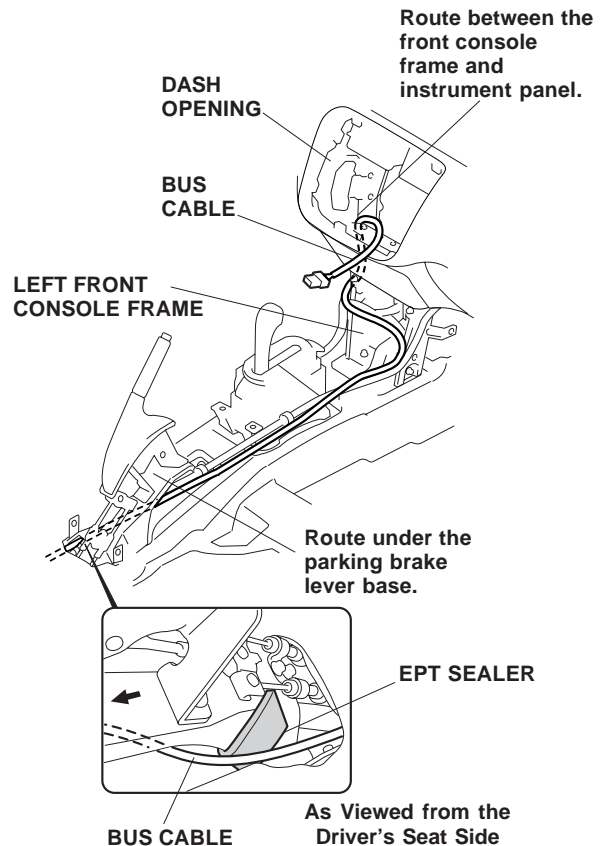

31. To protect the BUS cable, attach the EPT sealer to the edge of the panel hole where the BUS cable may interfere with it. Thoroughly clean the area where the EPT sealer will attach with the isopropyl alcohol.
32. Route the BUS cable connector through the clearance between the left front console frame and the dashboard and out through the dash opening.

33. Pull the vehicle harness 20-pin connector (blue) and BUS cable connector out through the dash opening; then secure them to the vehicle harness with the wire tie in the area shown.

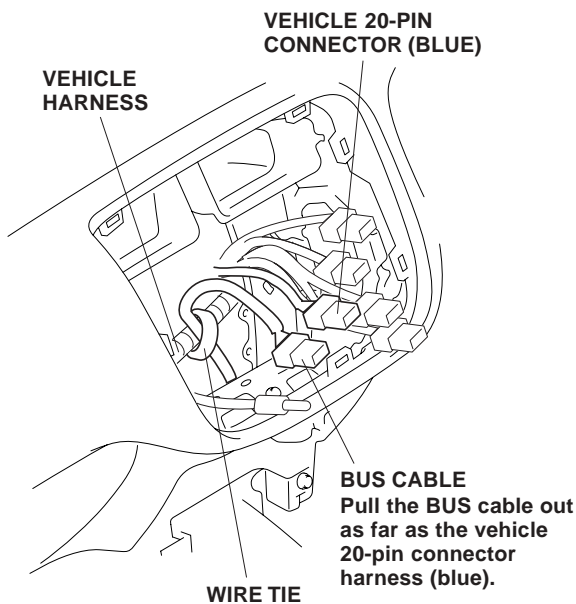

34. Secure the BUS cable to the vehicle harness with the nine wire ties in the areas shown.

Secure the BUS cable with the wire tie so it will not interfere with the inner cables.

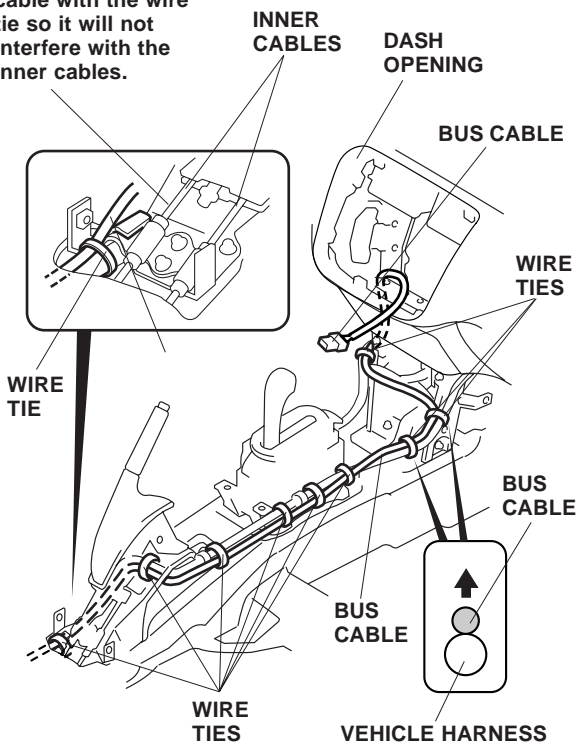

35. First secure the BUS cable to the vehicle's harness with the one wire; then make loops in the BUS cable and secure them with the two wire ties as shown.

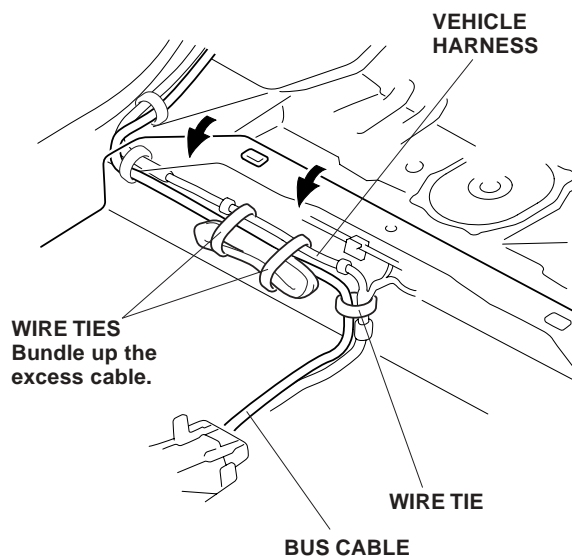

### Cutting the Trunk Front Trim Panel

36. Reinstall the right trunk side trim panel removed in step 6.
37. Locate the two marks on the back of the trunk front trim panel. Cut the panel along the marks with a utility knife.

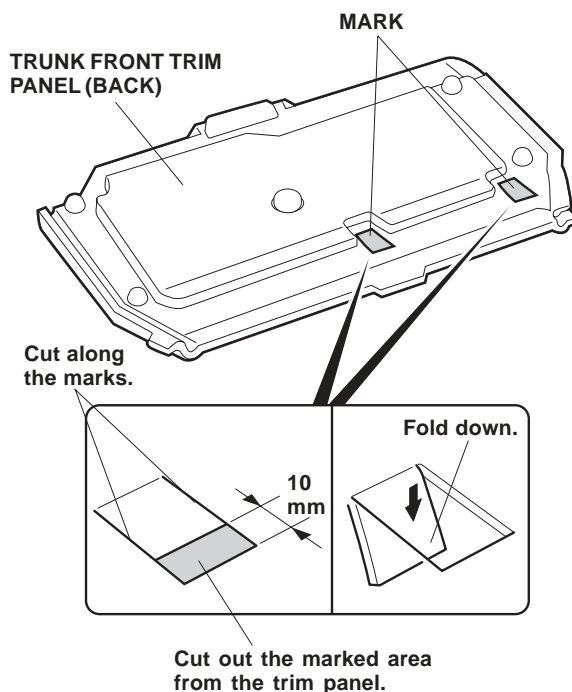

38. Remove the two bolts temporarily installed to secure the CD changer bracket in step 24, and lift the bracket away from the battery duct to produce a clearance between the bracket and battery duct.

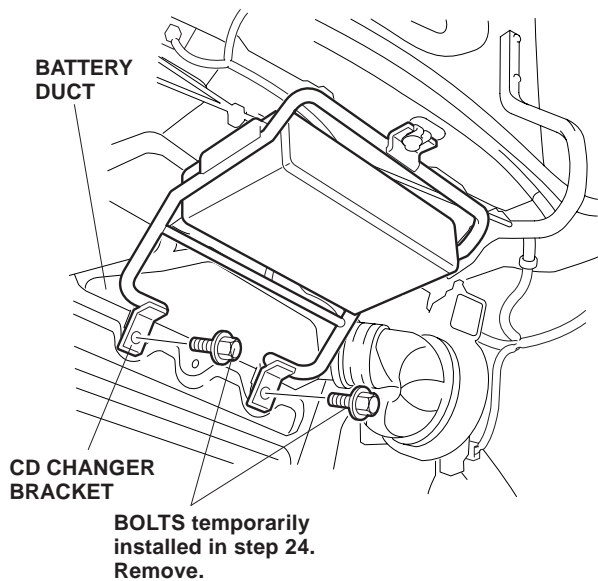

39. Slide the trunk front trim panel into the clearance between the bracket and battery air duct, and align the bolt holes in the battery duct and cutouts in the trim panel made in step 37, as shown.

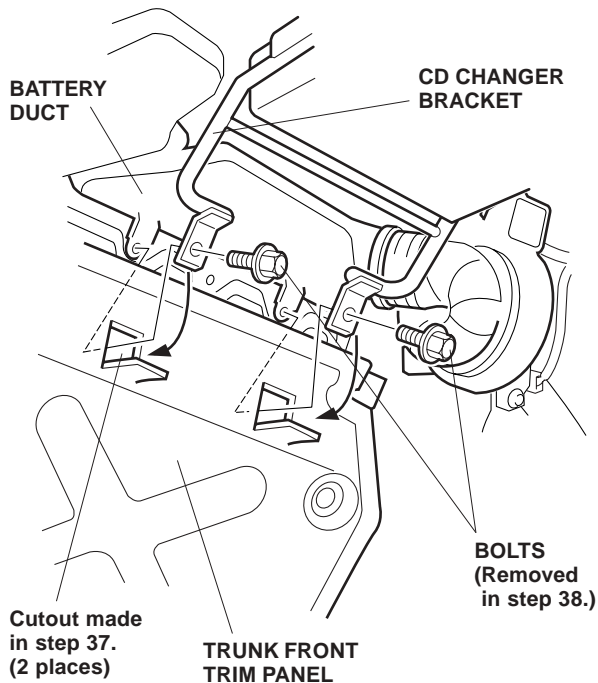

40. Secure the CD changer bracket to the battery duct with the two bolts removed in step 38.
41. Reinstall the trunk front trim panel.

42. Plug the BUS cable connector, vehicle 20-pin connector (blue), and antenna lead into the rear of the audio unit.

#### With a Radio and Pocket

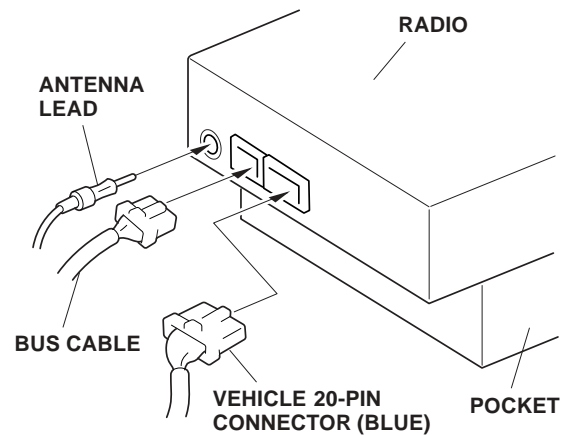

#### With a Radio and Cassette Player

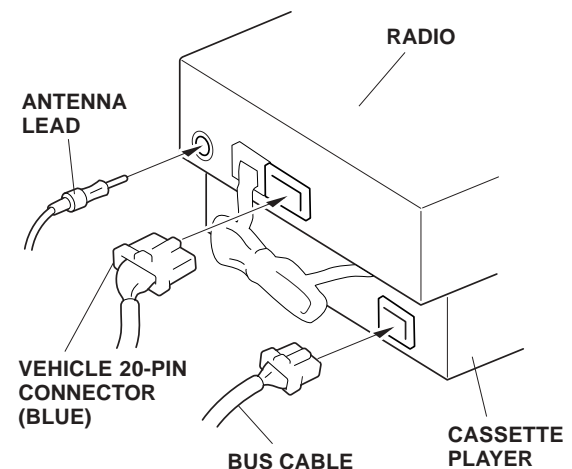

43. Connect the five vehicle connectors to the center panel, and reinstall the center panel.

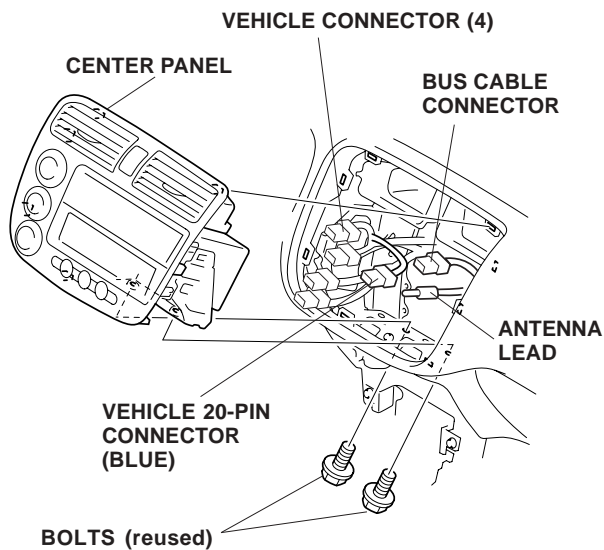

44. Check that all wire harnesses are routed properly and all connectors are plugged in.
45. Reconnect the negative cable to the battery.
46. Reset the clock and the radio station presets.
47. Check the operation of the CD changer as described in the Owner's Manual supplied.
48. Check the operation of the accessory socket or cigarette lighter.
49. Reinstall all removed parts. Be sure that all retaining clips and tabs are securely fastened.
50. Put the CD changer Owner's Manual and the shipping clips (removed in step 16) in the glove box for your customer.
51. Do the ECU idle learn procedure.
- Make sure all electrical items are turned off.
  - Start the engine. Hold the engine speed at 3,000 rpm with no load (in Park or Neutral) until the radiator fan comes on.
  - Let the engine idle for about 5 minutes with the throttle fully closed and with all electrical items off.

NOTE: If the radiator fan comes on during this step, the time when it is operating must not be included in the 5 minutes.

NOTE: When the battery terminals are disconnected: "Remaining Capacity of the IMA Battery" is not indicated when the engine is started. It will be indicated after driving for about 30 minutes. At that time, "regeneration" will be lowered temporarily, but this is normal.