



INSTALLATION INSTRUCTIONS

Accessory

SIDE UNDER SPOILER

Application

CIVIC
4-DOOR

Publications No.

All 30834

Issue Date

SEP 2005

PARTS LIST

Left side under spoiler

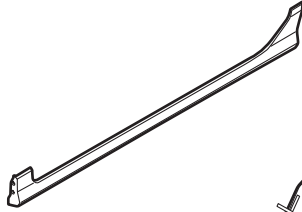

Right side under spoiler

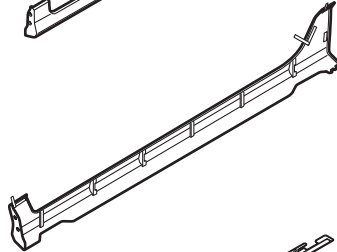

2 Side lower brackets

The side lower bracket gets deformed easily. Handle the part carefully with your both hands when you move it.

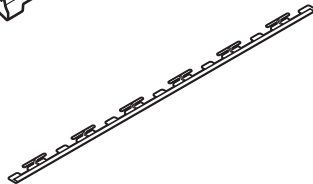

Template

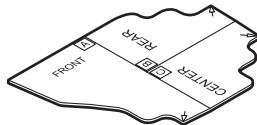

4 Self-tapping screws



2 Under brackets

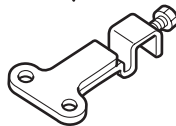

4 Screws



TOOLS AND SUPPLIES REQUIRED

Phillips screwdriver

Tape measure

Felt-tip pen

Shop towel

Isopropyl alcohol

Masking tape

Scissors

Utility knife

Touch-up paint

8 mm Wrench

Gloves

Heat gun

INSTALLATION

NOTE:

- Be careful not to damage the body finish when installing the side under spoilers.
- Install the left side under spoiler first, then install the right side under spoiler.
- If oil, moisture, dust, etc. is not thoroughly removed, the side lower bracket may be detached and the side lower skirt may come off the vehicle. Be sure to clean the vehicle before installation.
- These installation instructions show the left side under spoiler being installed. The same procedure applies to installing the right side under spoiler.
- Wear gloves to protect your hands during handling the side lower bracket.
- This side under spoiler kit should be installed only if the ambient air temperature is 60°F (15°C) or above.
- To allow the adhesive to “cure”, do not wash the vehicle for 24 hours.

1. Trial-fit the left side under spoiler on the vehicle body to check the installation position. Set the under spoiler aside, then, using isopropyl alcohol on a shop towel, clean the surface of the vehicle thoroughly where the left side under spoiler will be attached to ensure secure adhesion of the double-sided adhesive tape.

Thoroughly clean the surface with isopropyl alcohol where the left side under spoiler will be attached.

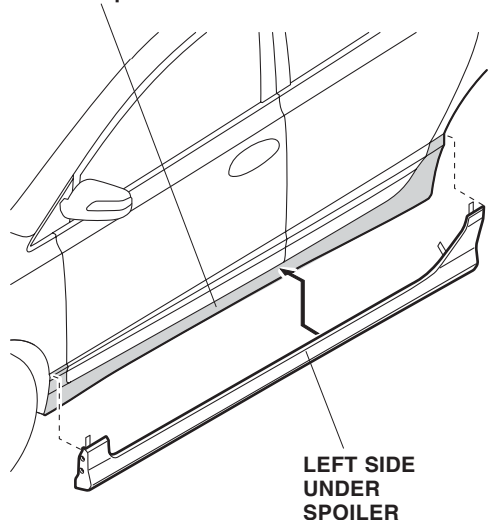

2. Using a tape measure and felt-tip pen, measure and mark the body area shown.

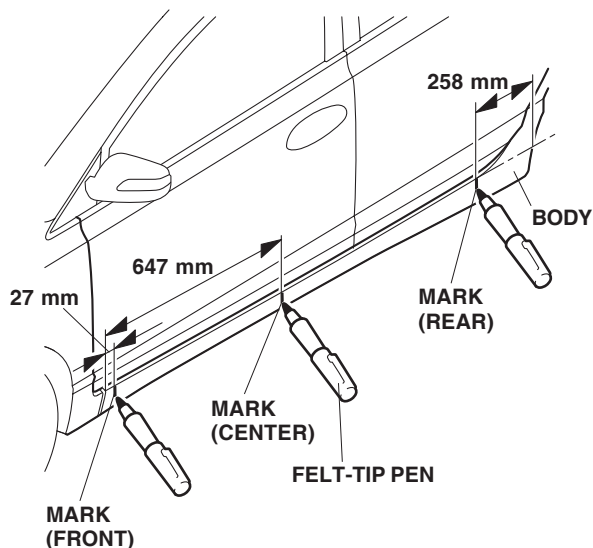

3. Using a utility knife, measure and cut both ends of the adhesive backing attached to the inner side of the side lower bracket. Remove the cut pieces of the adhesive backing from both ends.

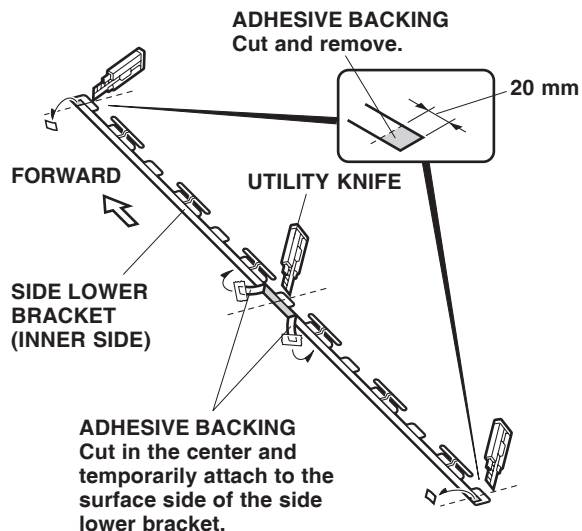

4. Using a utility knife, cut the center of the adhesive backing attached to the side lower bracket.
5. Attach a piece of adhesive tape to each of the cut ends of the adhesive tape and temporarily attach them to the surface side of the side lower bracket.

- Open the left front door. Align the first rib on the front end of the side lower bracket with the mark (front) you made in step 2.

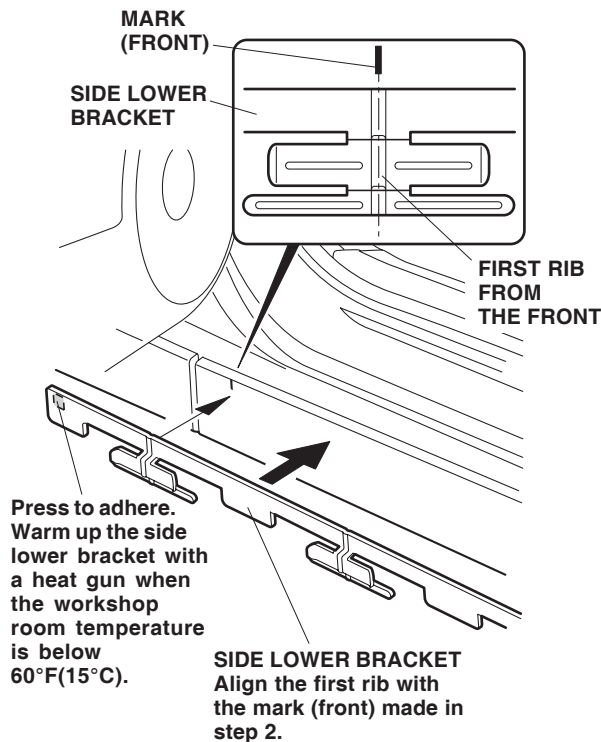

- Temporarily adhere the side lower bracket to the vehicle body by pressing the front end of the side lower bracket (where you removed the adhesive backing) against the vehicle body.
 - Position the side lower bracket on the vehicle body with care so you do not bend it, and adhere it to the vehicle body securely.
 - Wear gloves to protect your hands during this operation.
 - It is not a problem if the side lower bracket is slightly slanted, as vertical adjustment of the side lower bracket is not made in this step of the procedure.
 - If the side lower bracket comes off after temporarily adhering it, again clean the surface with isopropyl alcohol where the side lower bracket will attach.
 - When the workshop room temperature is below 60°F(15°C), warm up the side lower bracket to 60°F(15°C) or above before attaching it to the vehicle body.

- Open the left rear door. Position the rear (B) template on the mark (rear) you made in step 2. Position the top of the side lower bracket so that it lightly contacts the rear (B) template.

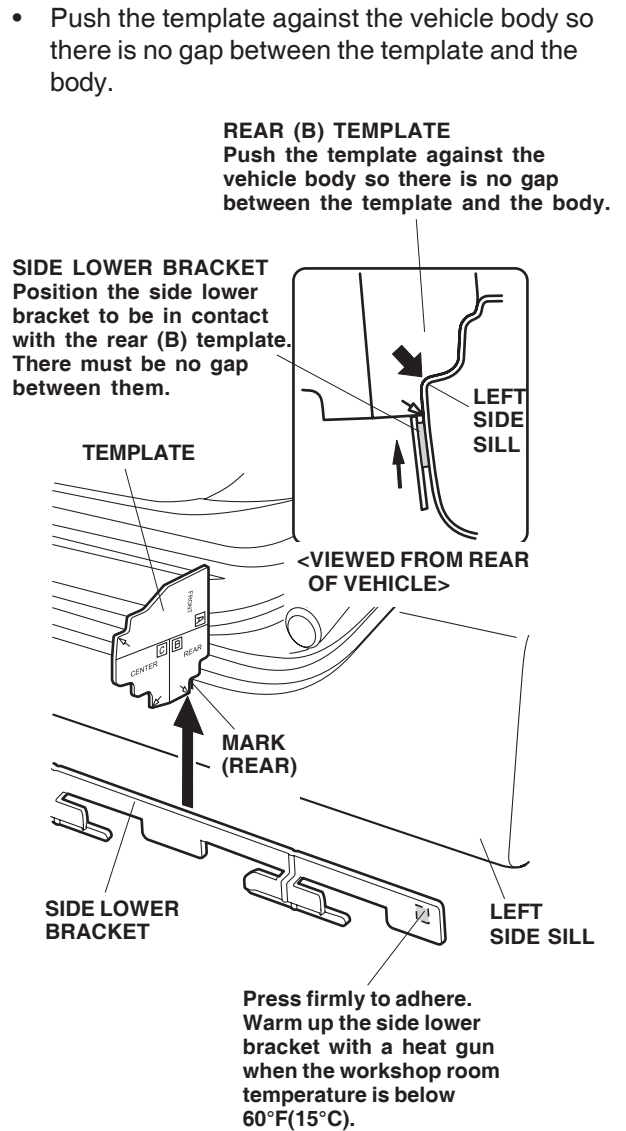

- Press the rear end of the side lower bracket (where you removed the adhesive backing) to adhere the part firmly to the vehicle body.
 - Position the side lower bracket on the vehicle body with care so you do not bend it, and adhere it to the vehicle body securely.
 - Wear gloves to protect your hands during this operation.
 - When the workshop room temperature is below 60°F(15°C), warm up the side lower bracket to 60°F(15°C) or above before attaching it to the vehicle body.

10. Detach the front end of the side lower bracket from the vehicle body. Position the front (A) template on the mark (front) you made in step 2. Align the top of the first rib from the front end of the side lower bracket with the front (A) template.
- Push the template against the vehicle body so there is no gap between the template and the body.

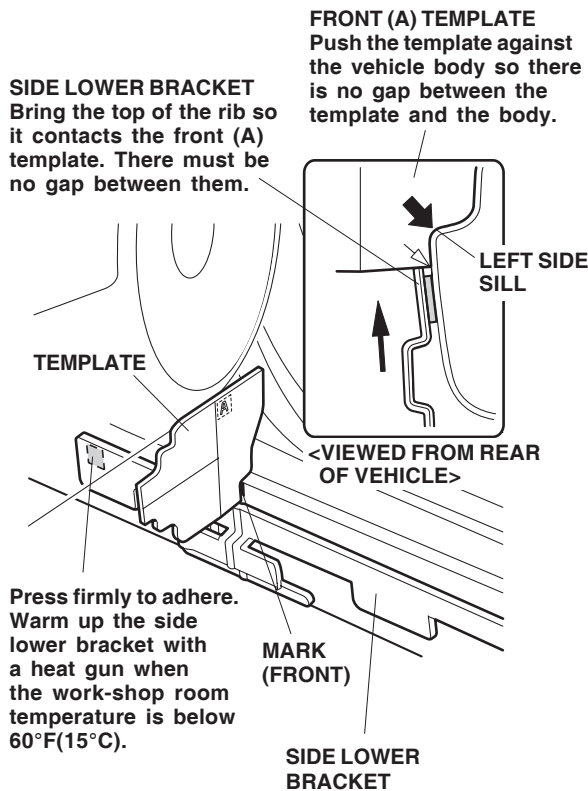

11. Press the front end of the side lower bracket (where you removed the adhesive backing) to adhere the part firmly to the vehicle body.
- Position the side lower bracket on the vehicle body with care so you do not bend it, and adhere it to the vehicle body securely.
 - Wear gloves to protect your hands during this operation.
 - When the workshop room temperature is below 60°F(15°C), warm up the side lower bracket to 60°F(15°C) or above before attaching it to the vehicle body.

12. Position the center (C) template on the mark (center) you made in step 2. While holding the ends of the side lower bracket that are adhered in position, position the top of the center of the side lower bracket with the center (C) template.
- Push the template against the vehicle body so there is no gap between the template and the body.

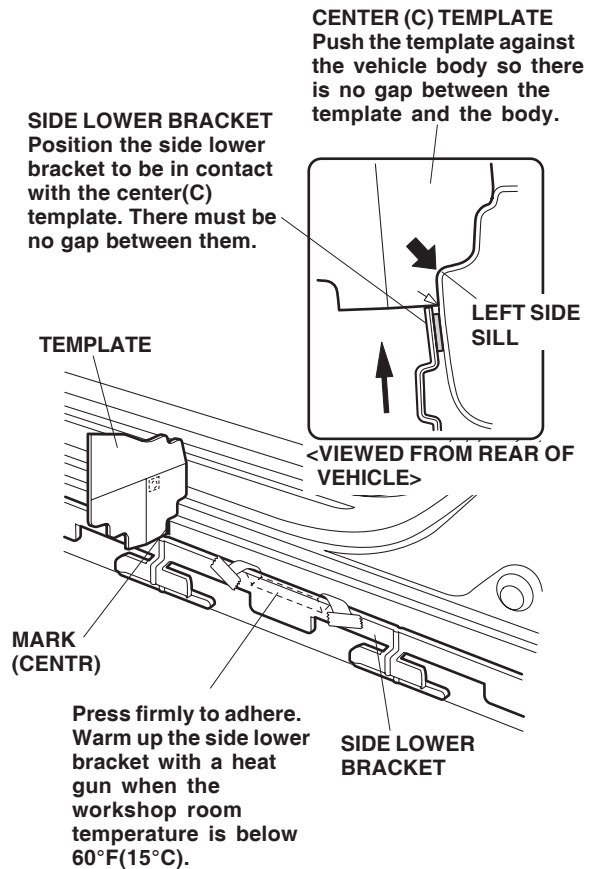

13. Press the side lower bracket in the center (where the adhesive tape was removed) to adhere it firmly.
- Position the side lower bracket on the vehicle body with care so you do not bend it, and adhere it to the vehicle body securely.
 - Wear gloves to protect your hands during this operation.
 - When the workshop room temperature is below 60°F(15°C), warm up the side lower bracket to 60°F(15°C) or above before attaching it to the vehicle body.
14. Close the left front door and left rear door.

- Press the side lower bracket lightly from the center to the ends while removing the adhesive backing.

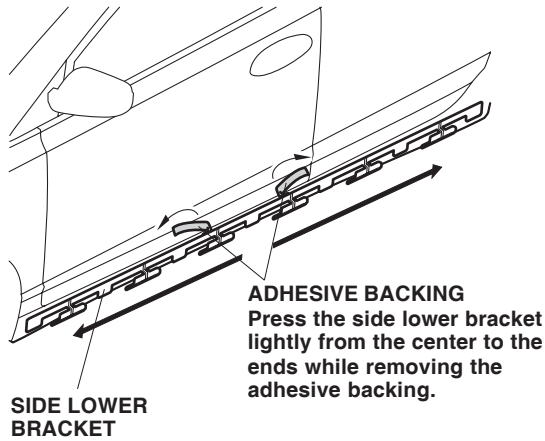

- When the workshop room temperature is below 60°F(15°C), warm up the entire side lower bracket to 60°F(15°C) or above before attaching it to the vehicle body.

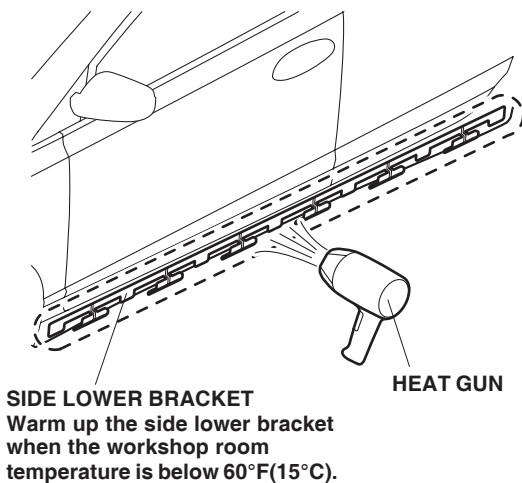

- Adhere the side lower bracket to the vehicle body by pressing firmly against the double-sided adhesive tape with the palms or fingers of your hands.

- Do not push the side lower bracket installation plates. It deforms the installation plates and prevents installing the side under spoiler.
- When the workshop room temperature is below 60°F(15°C), warm up the entire side lower bracket to 60°F(15°C) or above before attaching it to the vehicle body.
- Wear gloves to protect your hands during this operation.

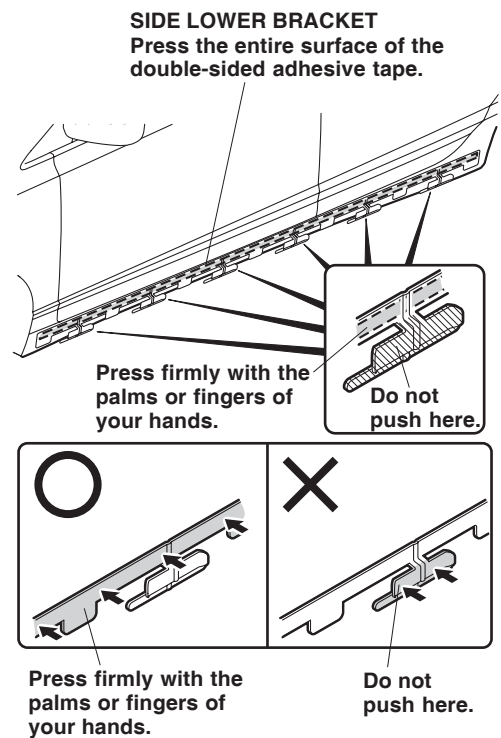

17. Turn the steering wheel all the way counterclockwise.

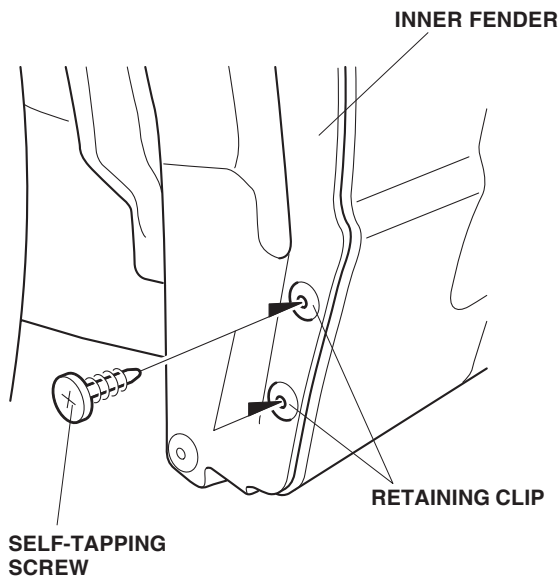

18. Using a self-tapping screw, pierce a hole through the center of the inner fender retaining clips.

19. Check the position of the under spoiler attachments by looking down at them from the top. Put the left side under spoiler against the side lower bracket, then slide it rearward a little while pushing it against the vehicle body with both hands.

- Make sure the side lower bracket installation plates (upper and lower) attach to the brackets of the left side under spoiler.

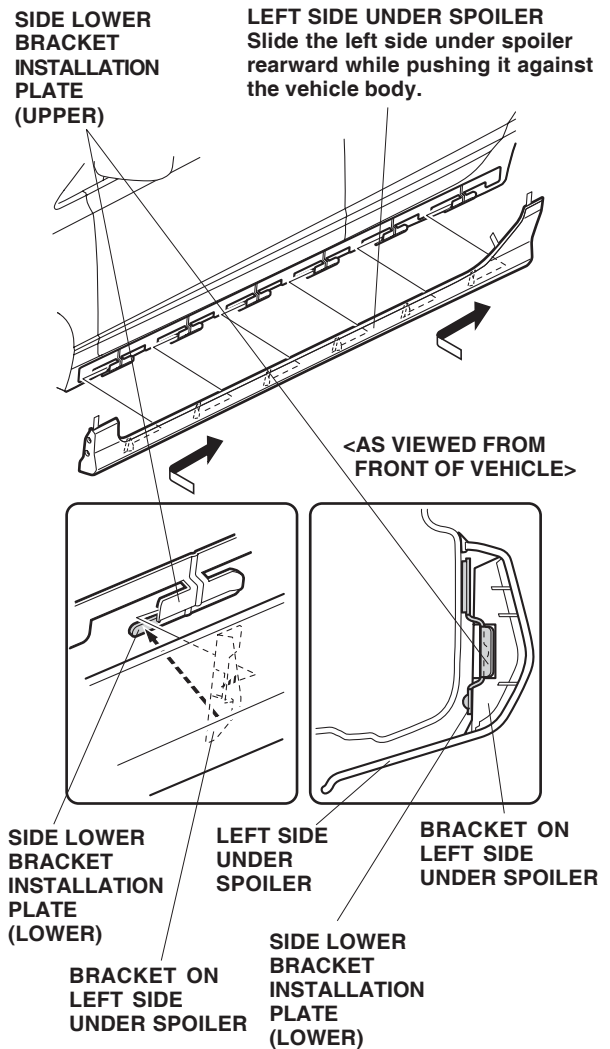

20. Check that all six brackets of the left side under spoiler are set in the side lower bracket installation plates.

- Visually check that there is no excessive gap between the left under spoiler and the vehicle. If an excessive gap is found, repeat step 19.

21. Fit the under bracket to the side under spoiler and mark the under coat.

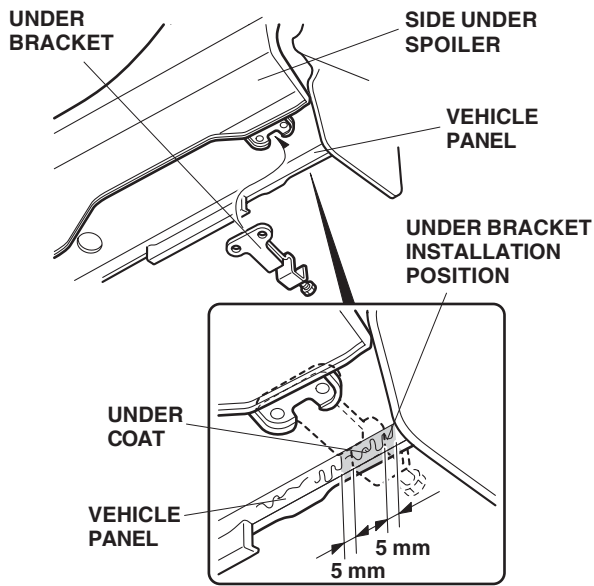

22. Cut into the marked area of the under coat with a utility knife, and file off the under coat from the surface side and inner side of the vehicle panel.

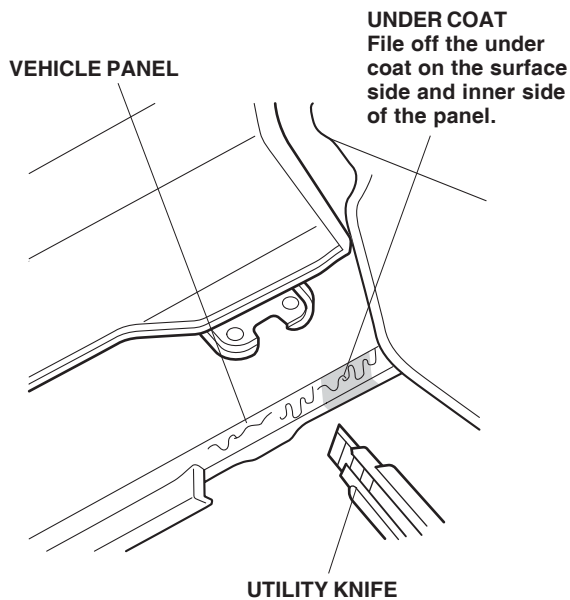

23. Apply touch-up paint to the vehicle panel in the area where you filed off the under coat.
- Do not install the under bracket until the touch-up paint is dry.

24. Gently tap on the left side under spoiler to remove any gap between the spoiler and the inner fender.

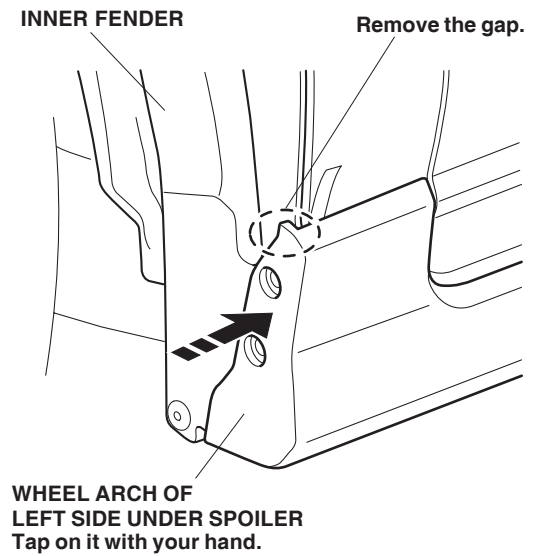

25. Loosely install the front self-tapping screws in the holes in the wheel arch of the left side under spoiler.

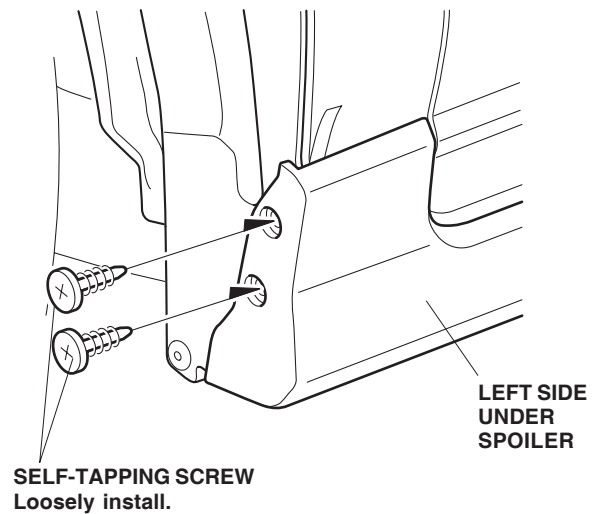

26. When the touch-up paint has dried, loosen the under bracket bolt completely until the washer on the bolt comes in contact with the under bracket. Take care not to allow the washer to come off. Do not loosen the under bracket bolt with a wrench, it can damage the washer. Loosen the under bracket bolt with your hand.

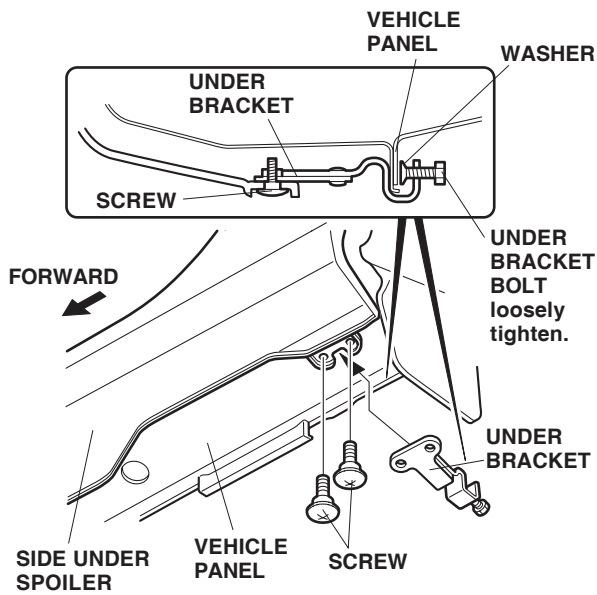

27. Position the under bracket on the side under spoiler and loosely install the two screws. Tighten down the under bracket bolt, but don't tighten it securely.
28. Gently pull the side under spoiler out, and remove the adhesive backing.

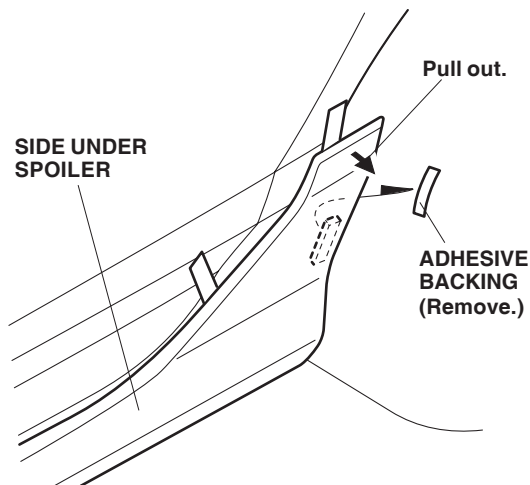

29. Remove the three adhesive tapes from the left side under spoiler. Press on the adhesive part of the side under spoiler firmly.

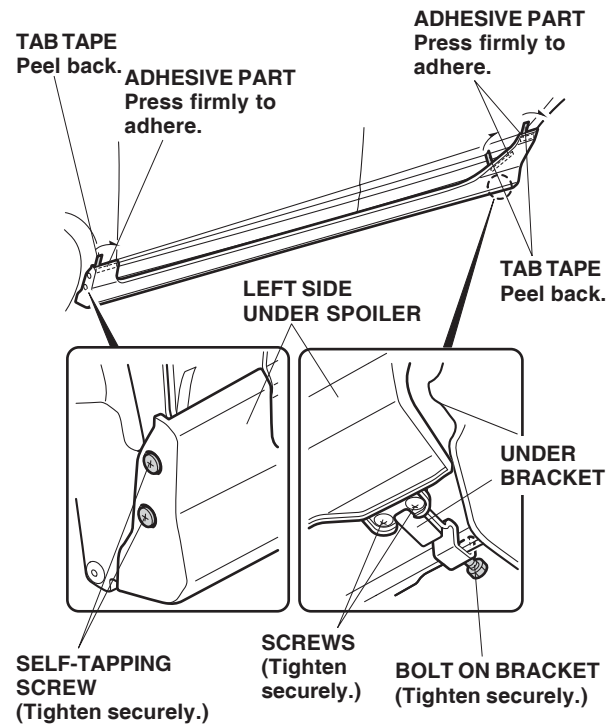

30. Tighten the two self-tapping screws and the two screws securely.
31. Tighten the bolt on the under bracket securely.
32. Repeat for the right side under spoiler.