



# INSTALLATION INSTRUCTIONS

Accessory <b>XM RADIO SYSTEM</b>	Application <b>2007 CIVIC 2 AND 4 DOOR (Si)</b>	Publications No. <b>All 33762</b>
		Issue Date <b>SEP 2006</b>

## PARTS LIST

**XM Radio Attachment (sold separately):  
P/N 08B15-SNA-100B**

Bus cable

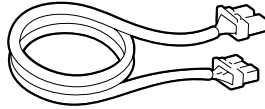

Front bracket

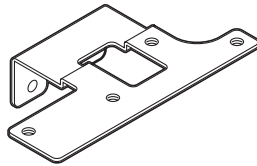

Rear bracket

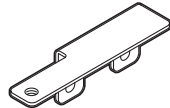

Clip



4 Pan screws



4 Washers



3 Flange bolts



Cover seal

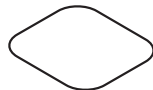

20 Wire ties

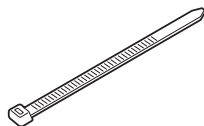

7 Wire ties with clip

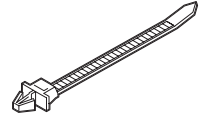

12 Cushion tapes



8 EPT sealers

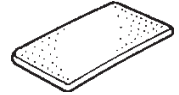

**XM Antenna (sold separately):  
P/N 08A15-0J1-100**

Antenna assembly

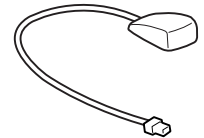

**Unit (sold separately):  
P/N 08A15-3J1-000**

XM radio unit

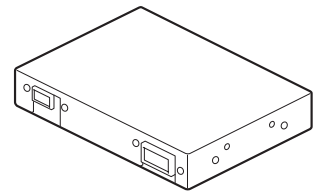

**2-Port Bus Cable (sold separately):  
P/N 08A31-0F1-000**

2-Port bus cable

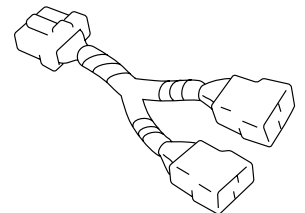

## TOOLS AND SUPPLIES REQUIRED

Phillips screwdriver  
Flat-tip screwdriver  
Utility knife  
Tape measure  
Shop towel  
Scissors  
Ratchet  
8 mm, 10 mm and 14 mm Socket  
8 mm, 10 mm and 14 mm Combination wrenches  
Isopropyl alcohol  
Rubber mallet  
Masking tape

## Illustration of the XM Radio System Installed on the Vehicle

### 2-door vehicle:

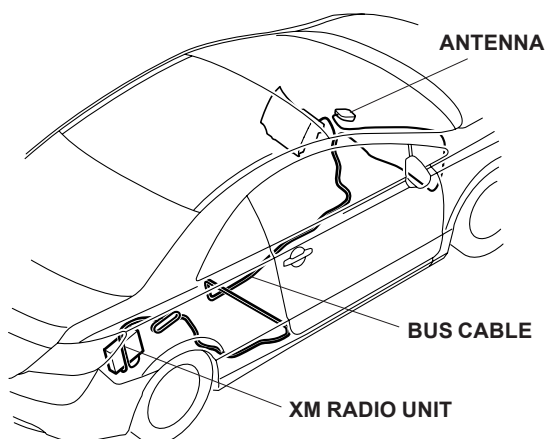

### 4-door vehicle:

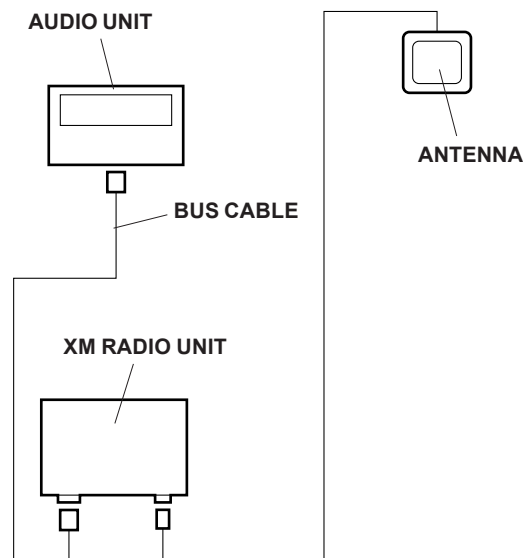
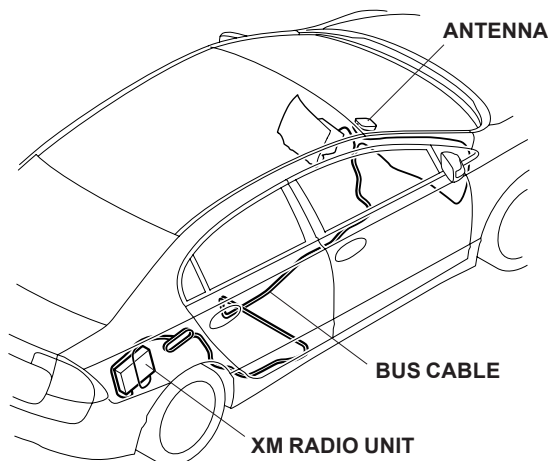

**Customer Information:** The information in this installation instruction is intended for use only by skilled technicians who have the proper tools, equipment, and training to correctly and safely add equipment to your vehicle. These procedures should not be attempted by “do-it-yourselfers.”

1. Make sure you have the anti-theft code for the radio, then write down the frequencies for the preset buttons.
2. Disconnect the negative cable from the battery.
3. Remove the passenger's dashboard lower cover (four clips and two pins).

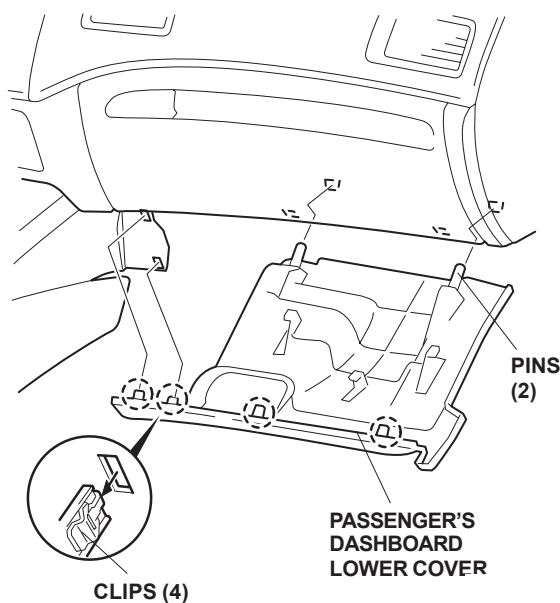

- Remove the two bolts under the glove box.

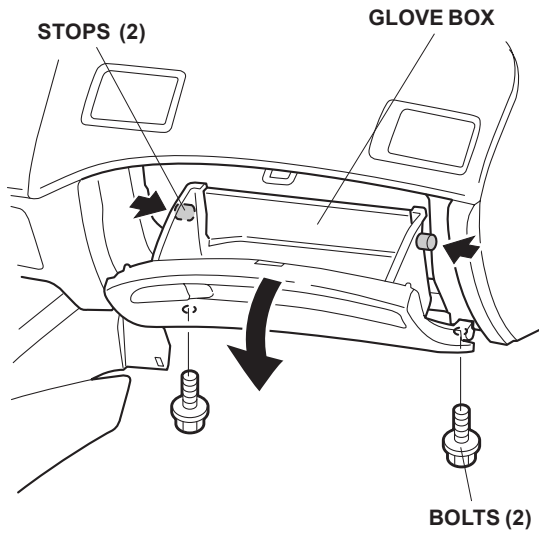

- Open and remove the glove box (two stops).
- Remove the driver's dashboard lower cover (eight clips).

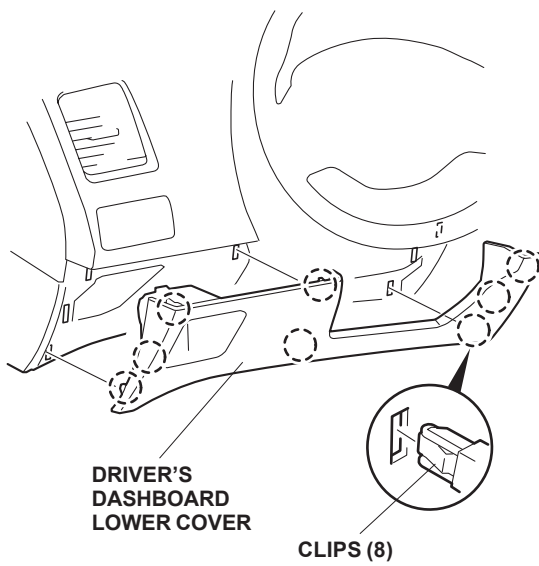

- Remove the inside cover from the front console pocket (two tabs).

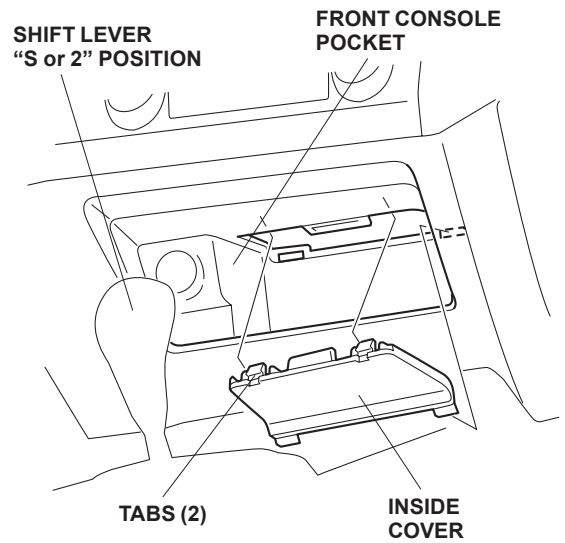

- Lower the tilt lever, then pull the steering wheel toward you.

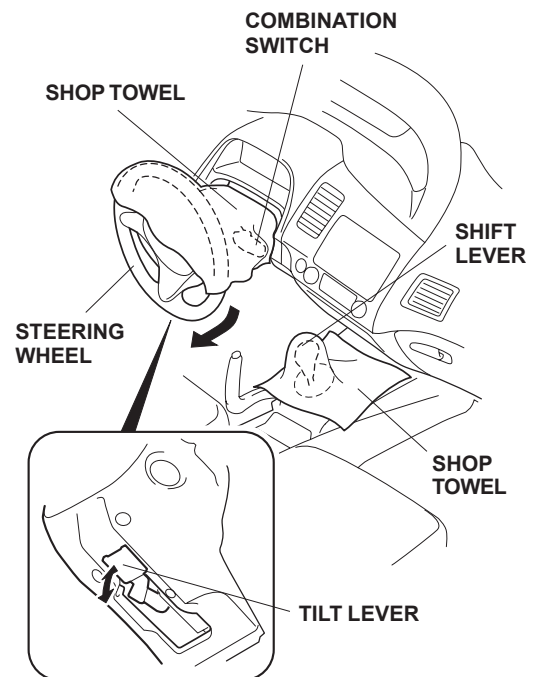

- To protect the dashboard area, put shop towels over the steering wheel and shift lever.

- Apply masking tape to the meter panel as shown, and remove the instrument panel (one self-tapping screw, 11 clips, and one connector).

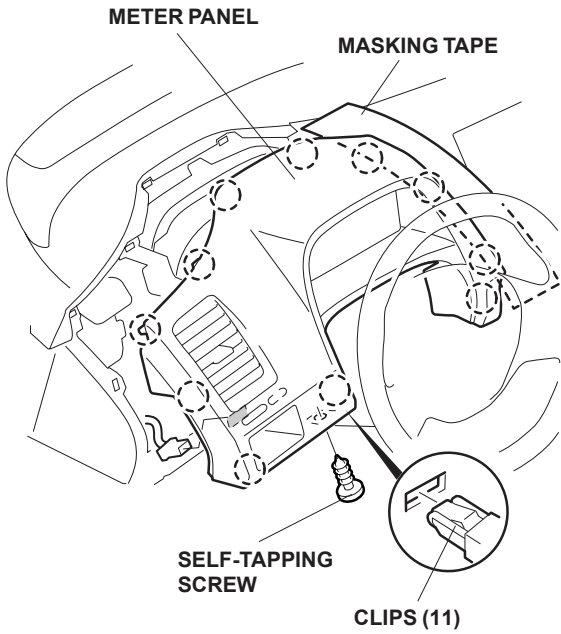

- Apply masking tape to the instrument panel as shown. Remove the center panel (two bolts, ten retaining clips, vehicle connectors, and the aspirator hose).

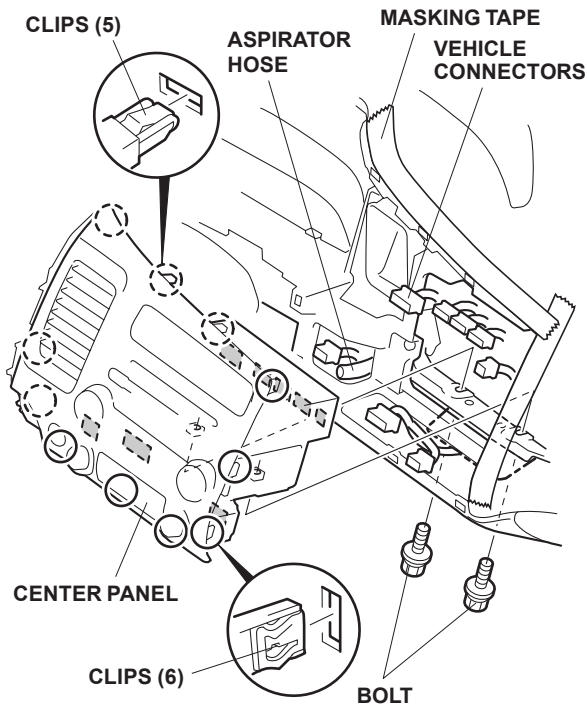

- Remove the weatherstrip from the opening edge of the right front door in the area shown.

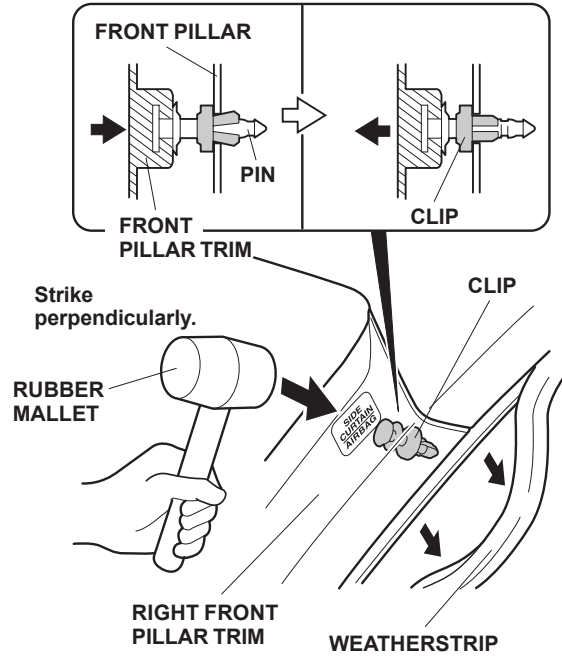

- Push the clip into the vehicle side by striking the top of the right front pillar trim in the part marked as "SIDE CURTAIN AIRBAG" with the rubber mallet perpendicular to the vehicle. Then remove the clip.

- Remove the weatherstrip in the area shown. Remove the right front pillar trim (two clips).

**4-door vehicle:**

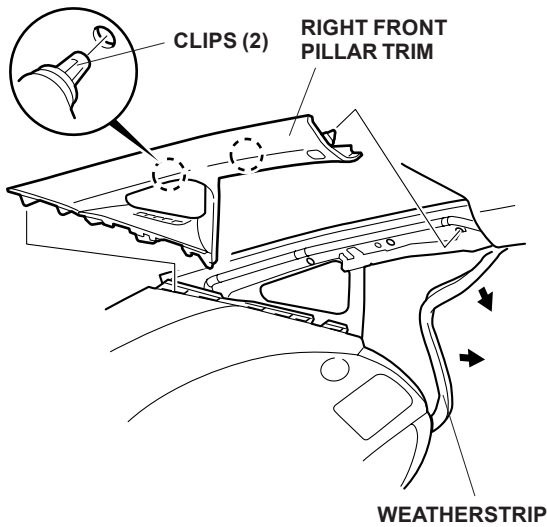

**2-door vehicle:**

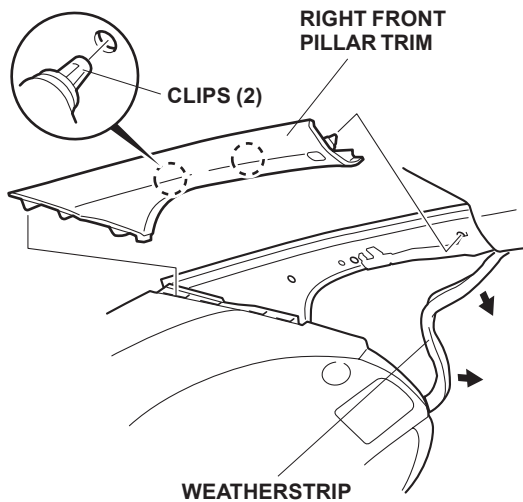

- Remove the cap from the right sunvisor (four retaining tabs).

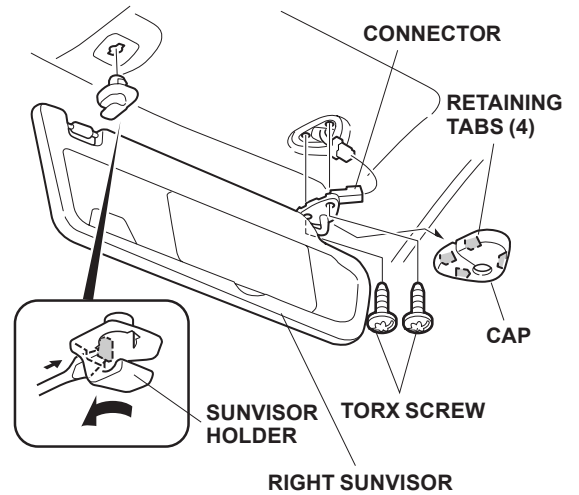

- Remove the right sunvisor (two T25 TORX screws, and unplug the vehicle connectors).
- Remove the sunvisor holder. Turn the holder 90°, then pull it out.
- Remove the center console cover.

**A/T vehicle:**

- Remove the center console cover (five clips).

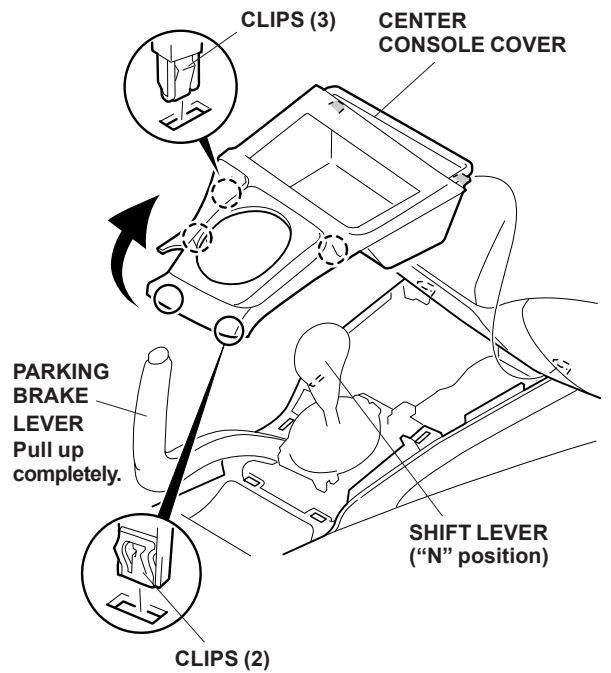

**M/T vehicle:**

- Pull down on the shift boot. Remove the shift knob by rotating counterclockwise.

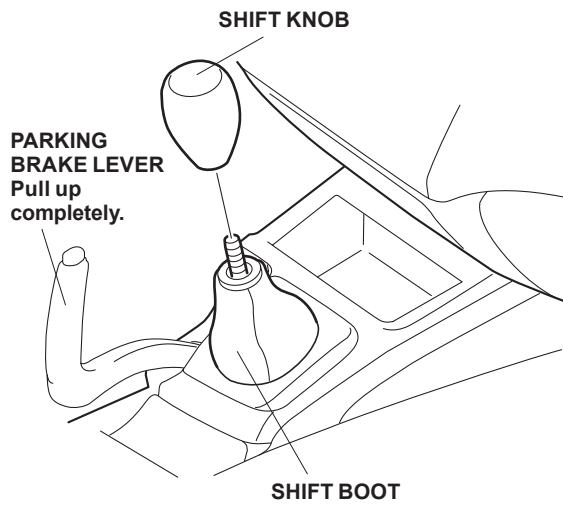

- Remove the center console cover (five clips).

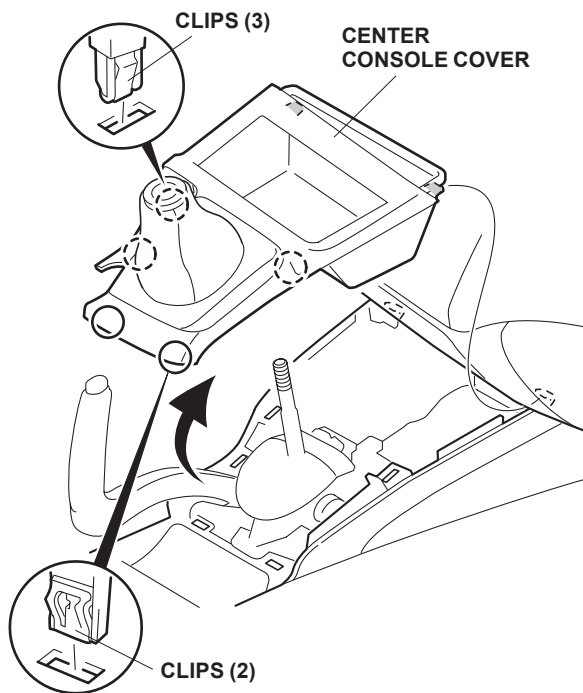

19. Open the center console lid, and remove the mat.

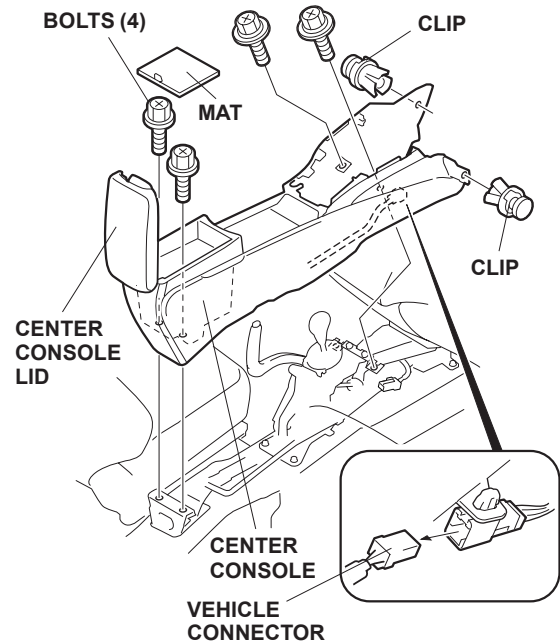

20. Remove the center console (four bolts, two clips, and the vehicle connector).

- **2-door vehicle:** Go on to step 21.
- **4-door vehicle:** Go to step 26.

**2-door vehicle:**

21. In the passenger's compartment, remove the bolt, and then remove the rear seat cushion (two hooks).

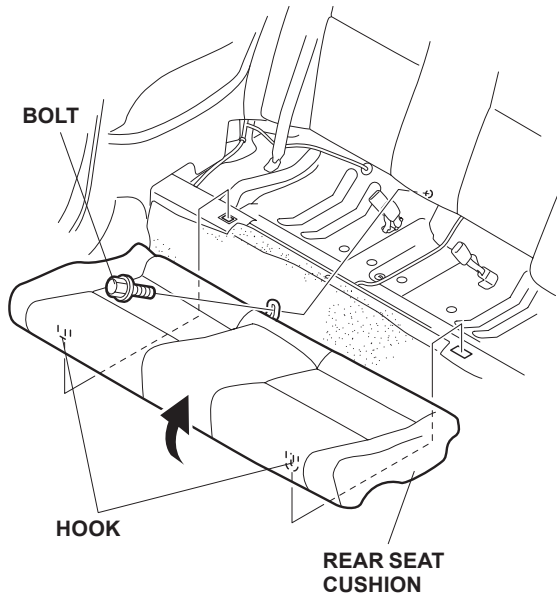

22. Open the trunk lid. Fold the rear seatback forward by pulling the levers under the rear parcel shelf. Remove the trunk floor mat (two clips).

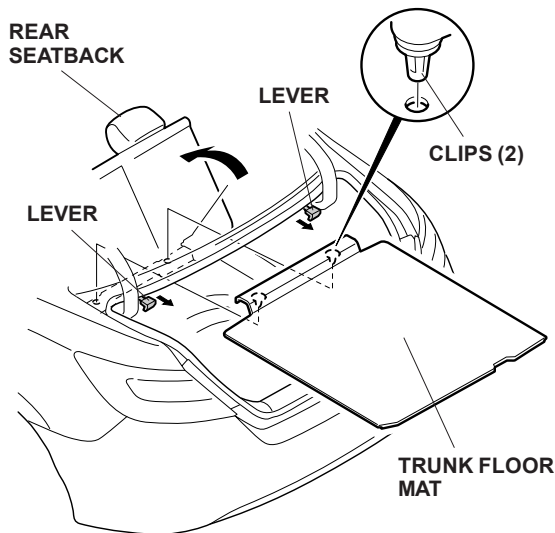

23. Remove the trunk weatherstrip in the area shown.

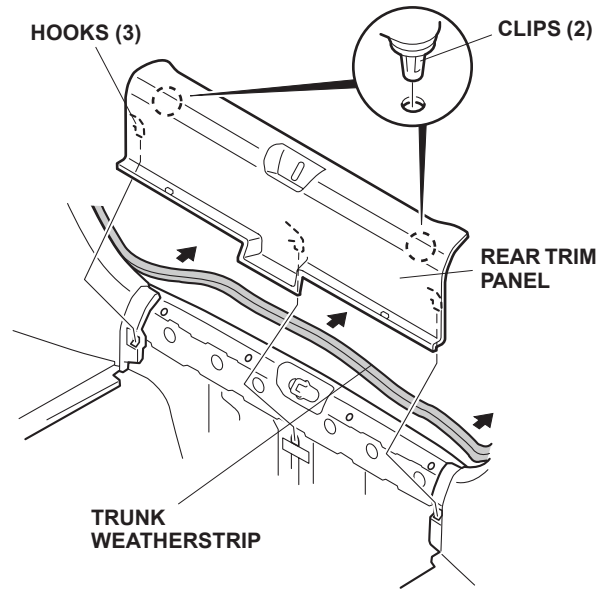

24. Remove the rear trim panel (two clips and three hooks).

25. Remove the weatherstrip. Remove the five clips and then the trunk right side trim panel.

- Go to step 34.

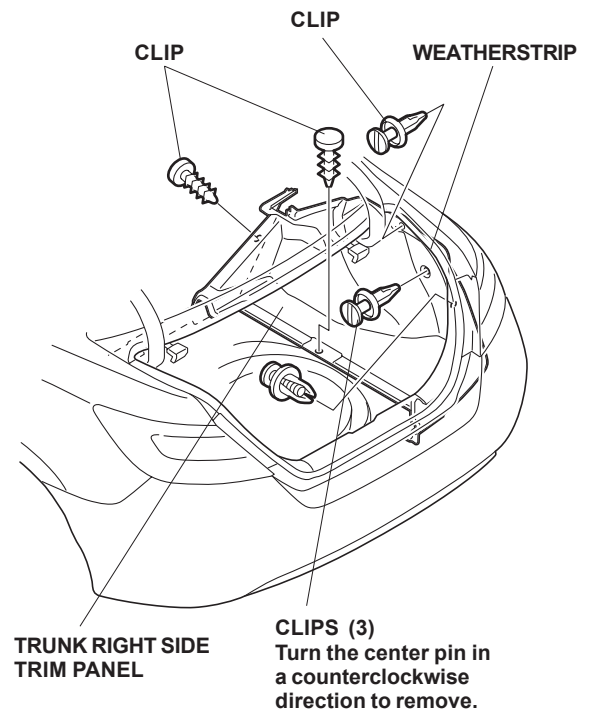

**4-door vehicle:**

26. Remove the bolt, and then remove the rear seat cushion (two hooks).

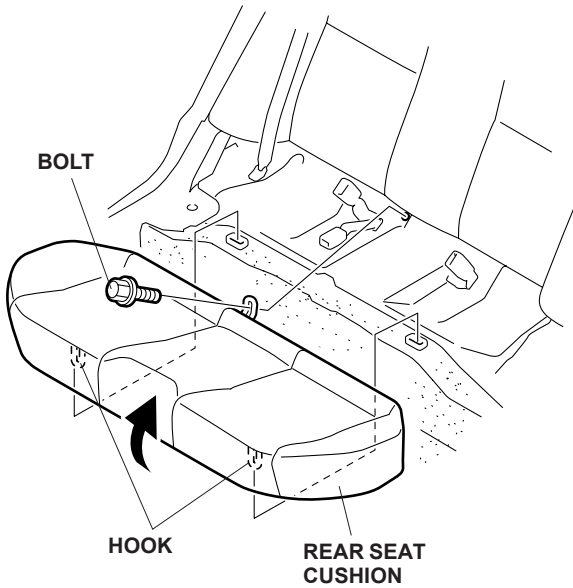

27. Remove the bolt and then the right seat side bolster.

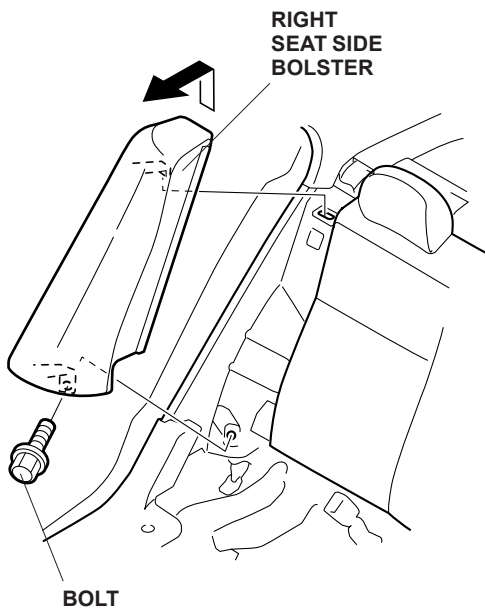

28. Remove the right rear side step trim (four clips and three retaining tabs).

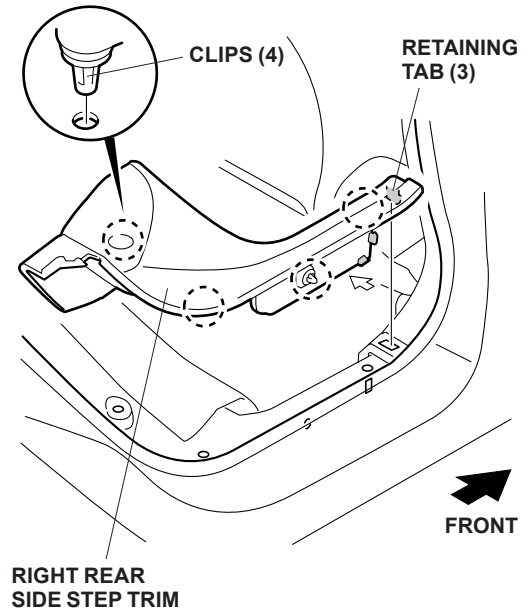

29. Open the trunk lid. Fold the rear seatback forward by pulling the levers under the rear parcel shelf.

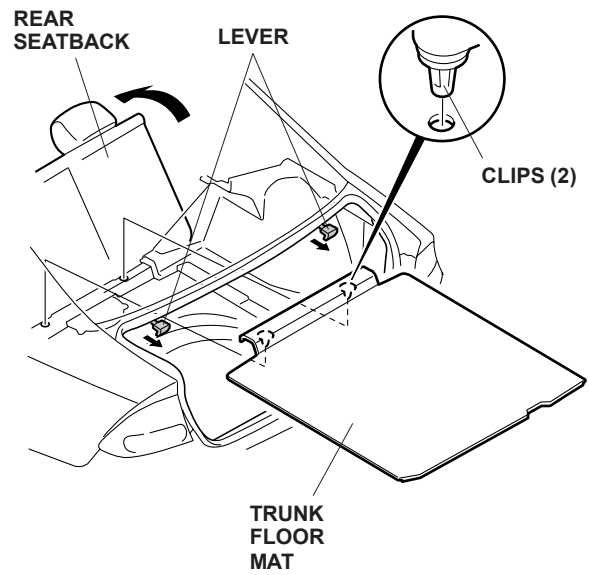

30. Remove the trunk floor mat (two clips).

31. Remove the weatherstrip in the area shown.

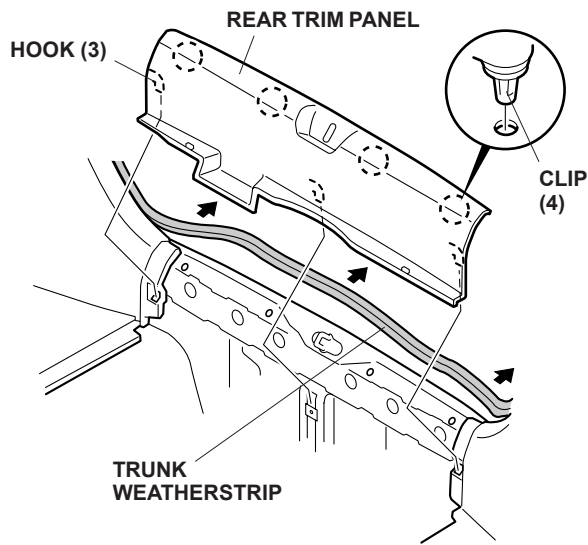

32. Remove the four clips and then the rear trim panel (three hooks).

33. Remove the weatherstrip. Remove the five clips, and then remove the trunk right side trim panel. Go to step 34.

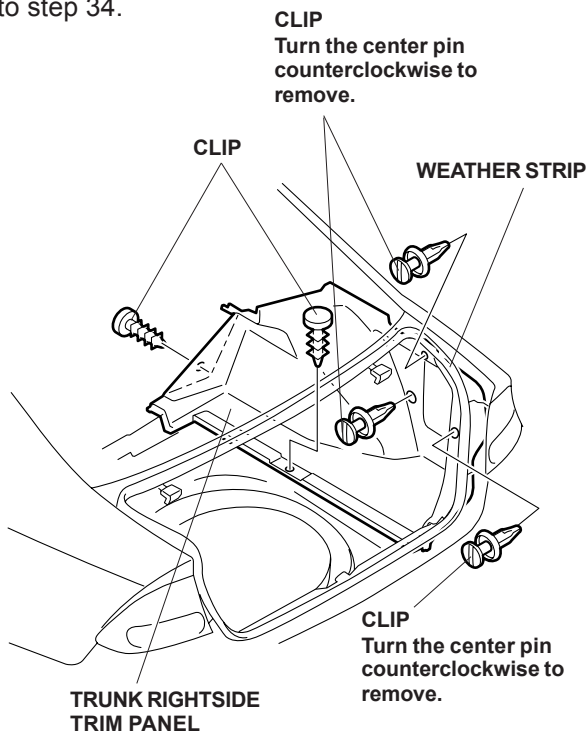

### Routing the Bus Cable

34. Route the Bus cable from the trunk as shown.

2-door vehicle:

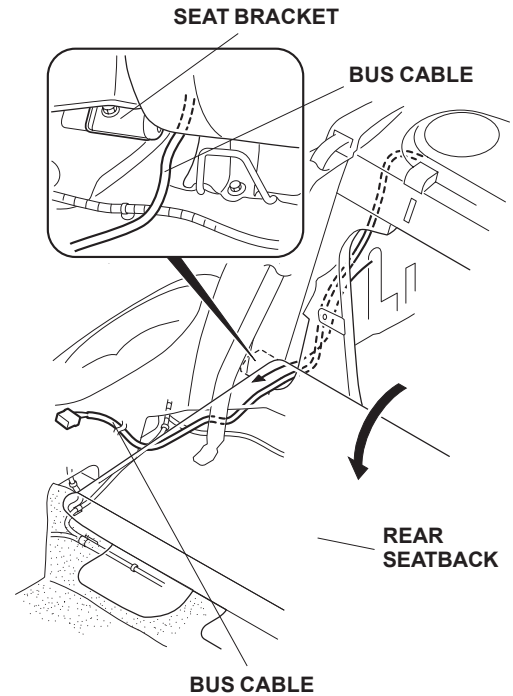

4-door vehicle:

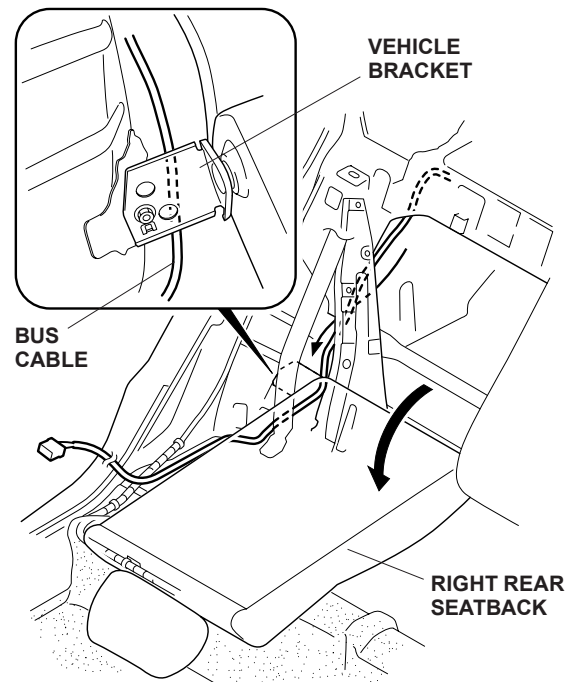

35. Lift up and lock the rear seatback, then remove the clip to pull back the floor carpet.

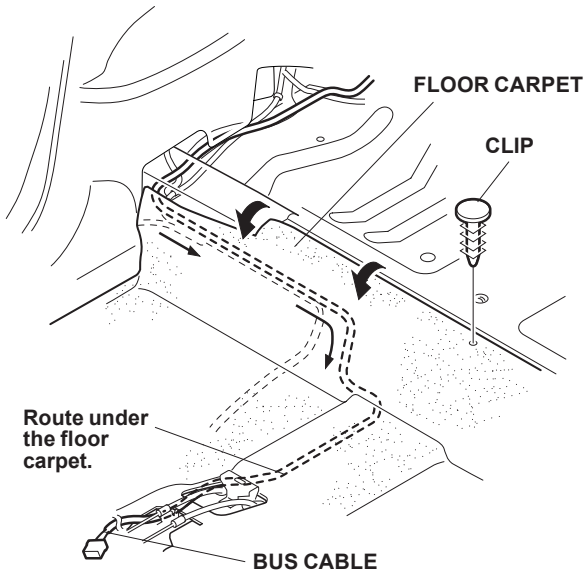

36. Route the Bus cable forward under the floor carpet.  
 37. Route the Bus cable forward along the vehicle harness, then pull the Bus cable connector out of the dash opening.

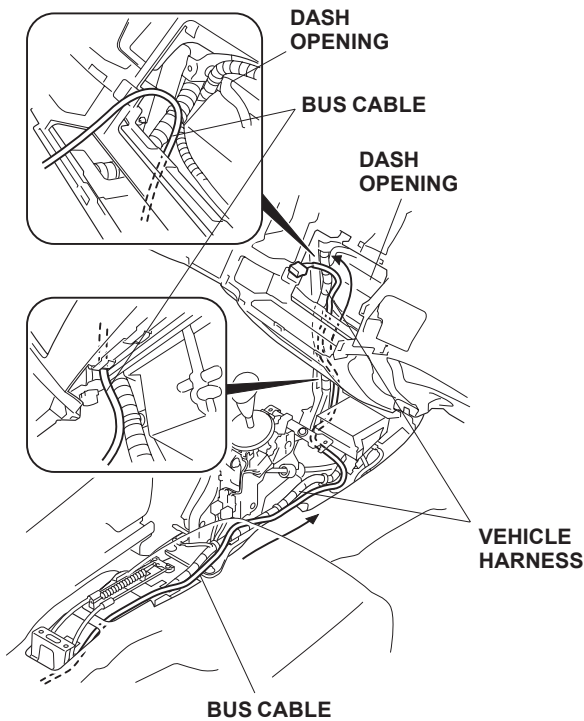

### Routing the Antenna Cable

38. Using isopropyl alcohol on a shop towel, clean the area shown on the inside of the windshield.

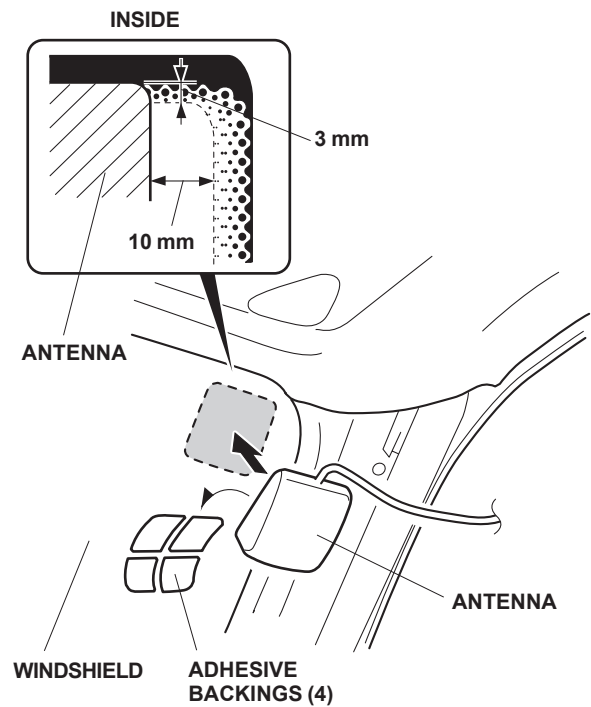

39. Remove the adhesive backings from the antenna, and attach the antenna to the windshield at the location shown. Install the antenna by applying sufficient pressure

40. Using isopropyl alcohol on a shop towel, clean the area shown on the outside of the windshield.

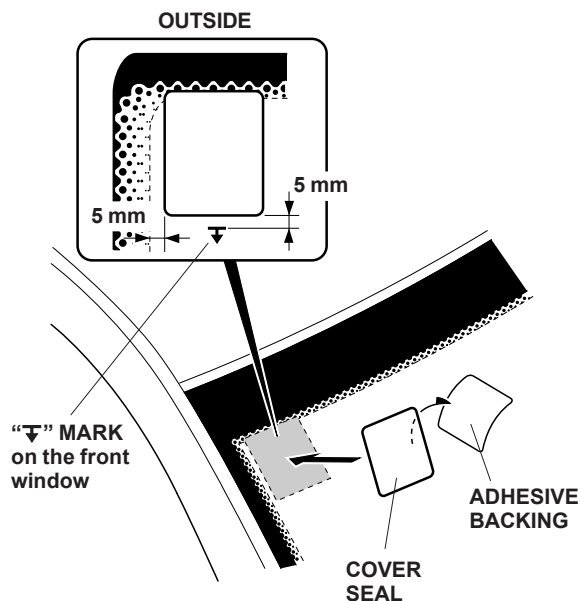

41. Remove the adhesive backing from the cover seal, then attach to the location shown.  
 42. With scissors, cut three EPT sealers in half.

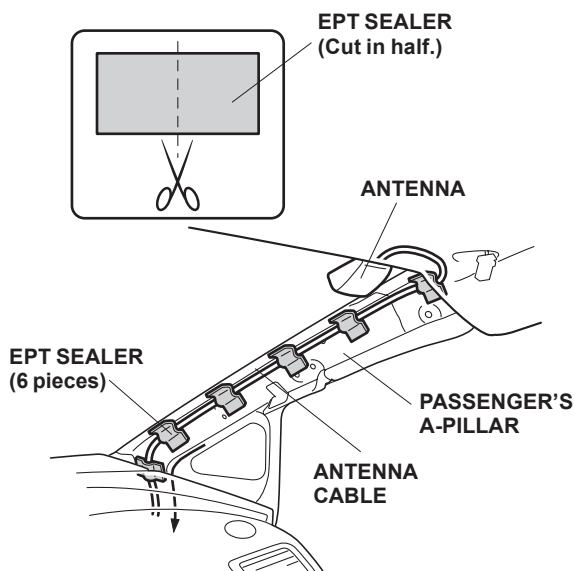

43. Route the antenna cable down along the passenger's A-pillar. Using the six pieces of EPT sealer, secure the antenna cable to the A-pillar panel in the areas shown.

44. Route the antenna cable down behind the dashboard stay and towards the glove box. Using three wire ties, secure the antenna cable to the vehicle harness.

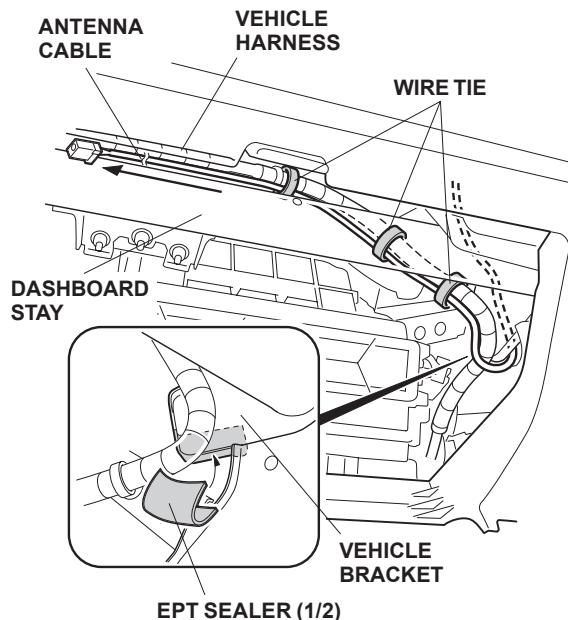

45. Using scissors, cut one EPT sealer in half. Attach one of the cut pieces of the EPT sealer to the vehicle bracket.  
 46. In the glove box opening, route the antenna cable along the vehicle harness and towards the audio unit opening.

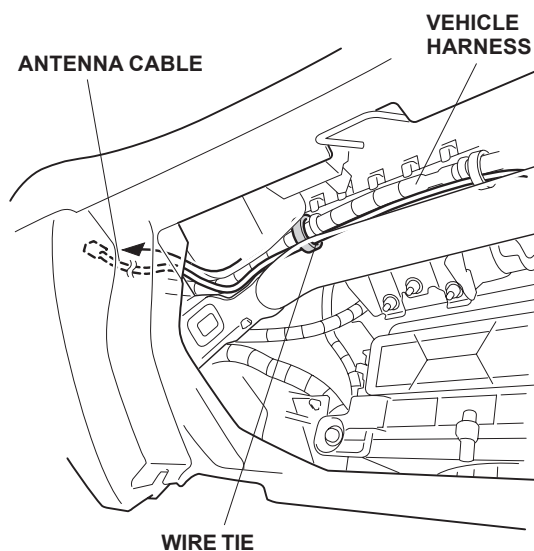

47. Using one wire tie, secure the antenna cable to the vehicle harness.

48. Route the antenna cable down along the Bus cable as shown.

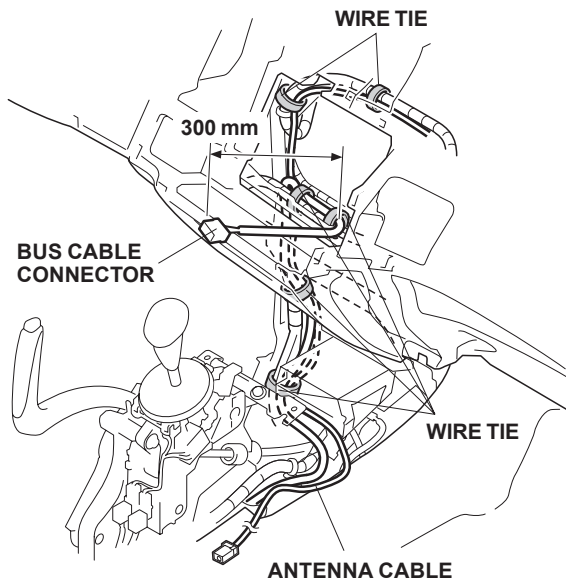

49. Using six wire ties, secure the Bus cable and antenna cable to the vehicle harness as shown.
50. Route the antenna cable along the Bus cable. Using three wire ties, secure the Bus and antenna cables to the vehicle harness.

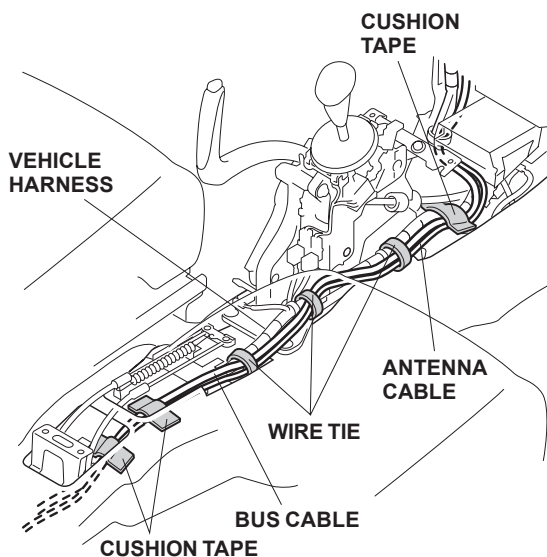

51. Using isopropyl alcohol on a shop towel, clean the areas shown where the cushion tapes will be applied. Secure the Bus and antenna cables to the floor with three cushion tapes.

52. Pull back the carpet. Using isopropyl alcohol on a shop towel, clean the areas where the cushion tapes will be applied. Route the antenna cable along the Bus cable. Using two cushion tapes, secure the Bus and antenna cables to the floor panel in the areas shown.

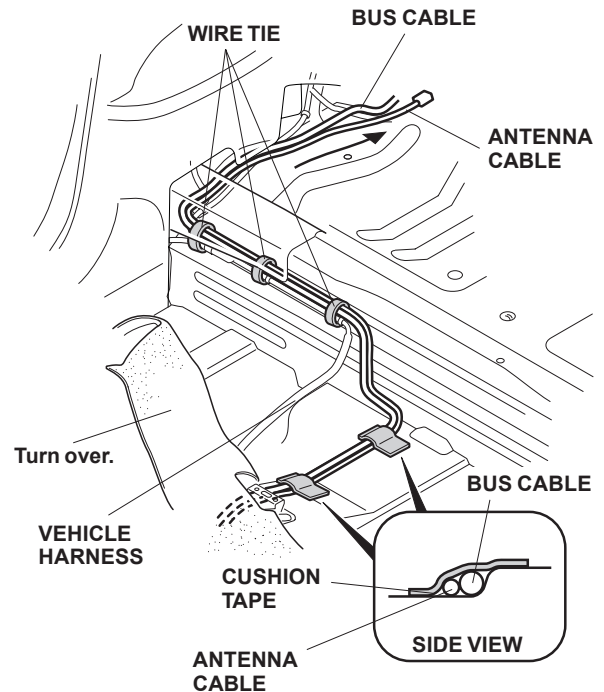

53. Using three wire ties, secure the Bus and antenna cables to the vehicle harness in the areas shown.
- 2-door vehicle: Go to step 54.
  - 4-door vehicle: Go to step 56.

**2-door vehicle:**

54. Route the antenna cable along the Bus cable.  
Using three wire ties, secure the Bus and antenna cables to the vehicle harness in the areas shown.
55. Using isopropyl alcohol on a shop towel, clean

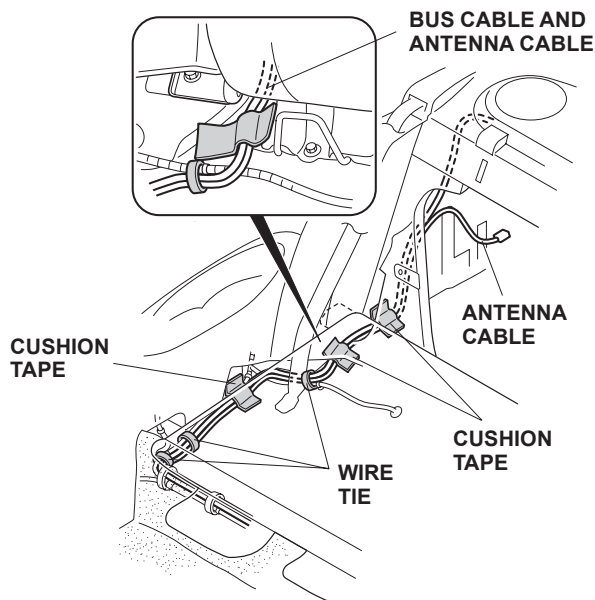

the areas where the cushion tapes will be applied. Using three cushion tapes, attach the bus and antenna cables to the floor panel in the areas shown.

- Go to step 58.

**4-door vehicle:**

56. Route the antenna cable along the Bus cable.  
With two wire ties, secure the Bus and antenna cables to the vehicle harness in the areas shown.

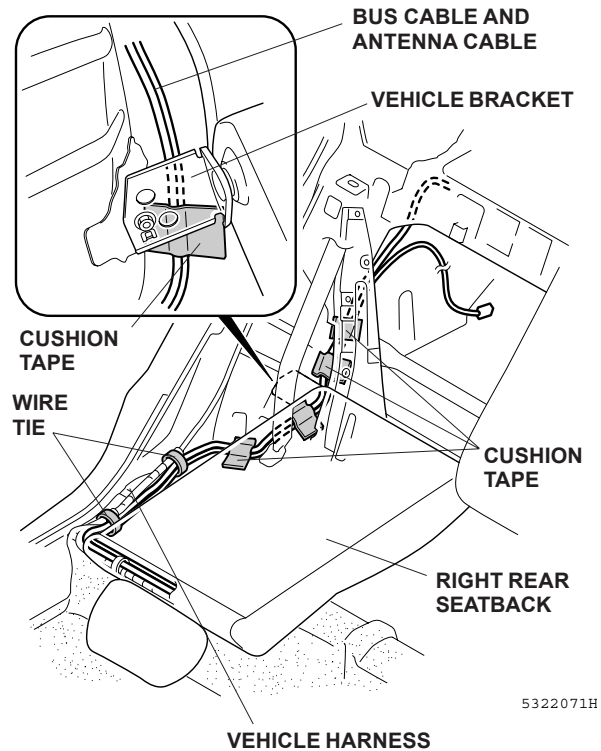

5322071H

57. Using isopropyl alcohol on a shop towel, clean the areas where the cushion tapes will be applied. With four cushion tapes, secure the Bus and antenna cables to the floor panel in the areas shown.

- Go on to step 58.

58. Using isopropyl alcohol on a shop towel, attach EPT sealer(s) to the trunk right inner panel in the area(s) shown.

**2-door vehicle:**

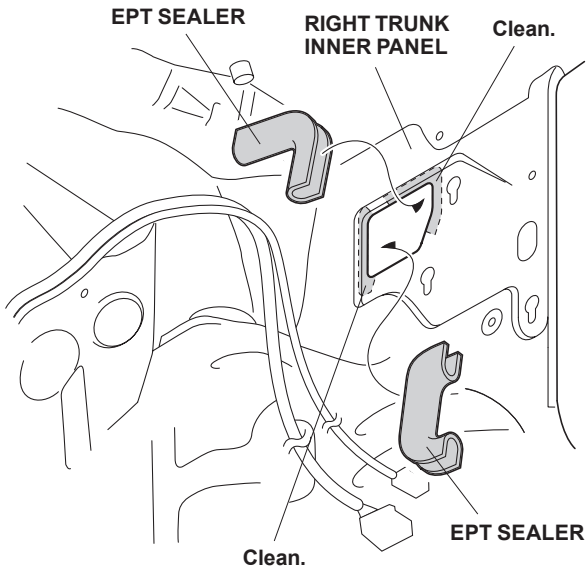

**4-door vehicle:**

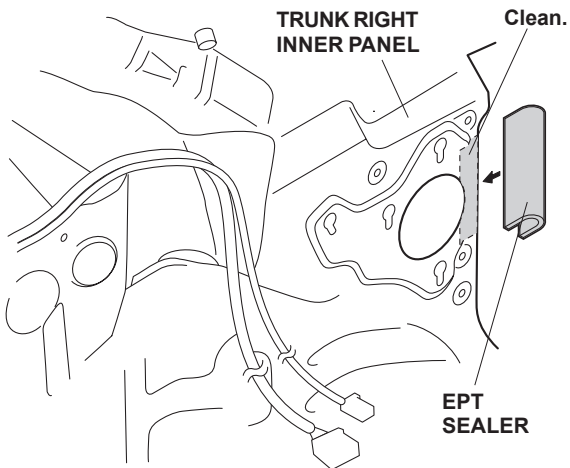

### Installing the XM Radio Unit

59. Using four pan screws and four washers, install the front and rear brackets to the XM radio unit.

- **2-door vehicle: Go to step 60.**
- **4-door vehicle: Go to step 69.**

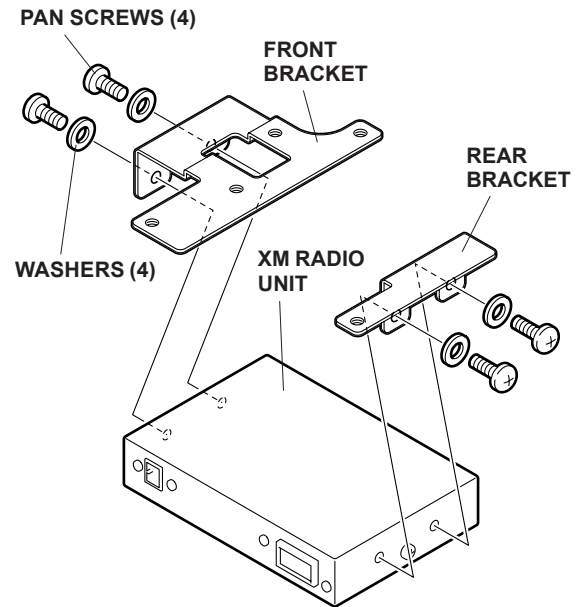

**2-door vehicle:**

60. Route the Bus and antenna cables behind the trunk right inner panel.

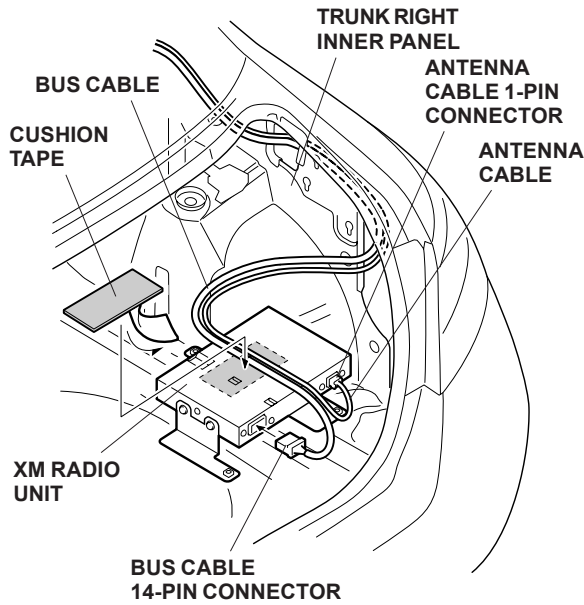

61. Plug the bus cable connector and the antenna cable connector into the XM radio unit.
62. Using one cushion tape, secure the Bus and antenna cables to the XM radio unit.

63. Loosely install three flange bolts to the front and rear brackets. On the front bracket, use the "B"-marked holes.

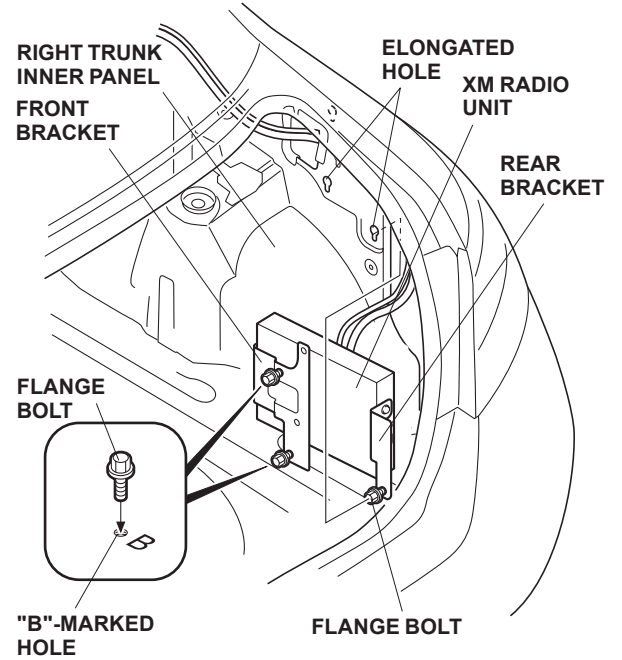

64. Place the XM radio assembly on the back of the trunk right inner panel. Set the three flange bolts into the elongated holes in the body panel.
65. Tighten the three flange bolts.

66. Using one wire tie with clip, secure the Bus and antenna cables in the area shown.

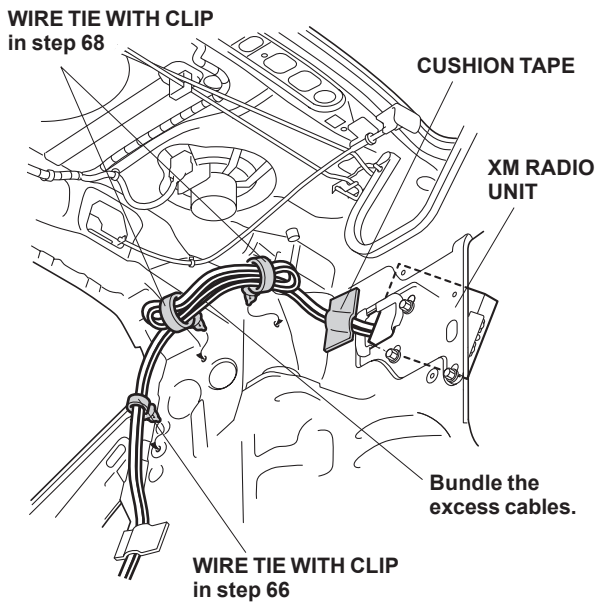

67. Secure the Bus and antenna cables to the trunk right inner panel in the area shown using one cushion tape.
68. Using two wire ties with clips, bundle the excess of the bus and antenna cables. Go to step 77.

#### 4-door vehicle:

69. Plug the Bus cable connector and the antenna cable connector into the XM radio unit.

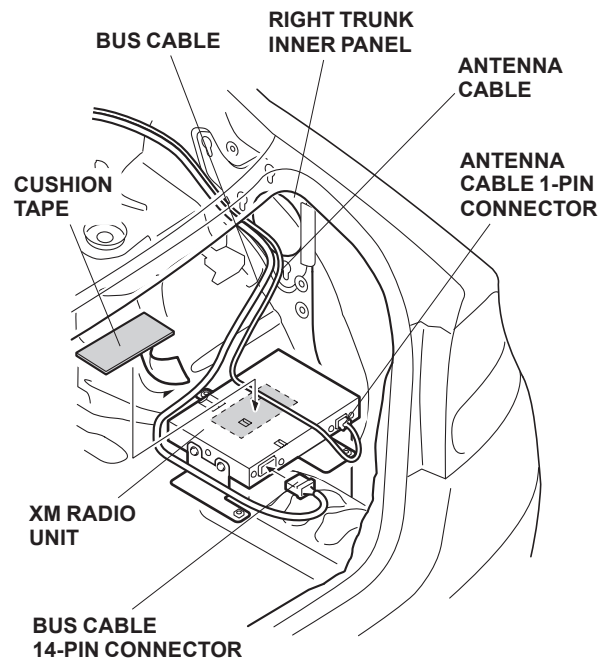

70. Using one cushion tape, secure the antenna cable to the XM radio unit in the area shown.

71. Loosely tighten three flange bolts to the front and rear brackets. On the front bracket, use the "A"-marked holes.

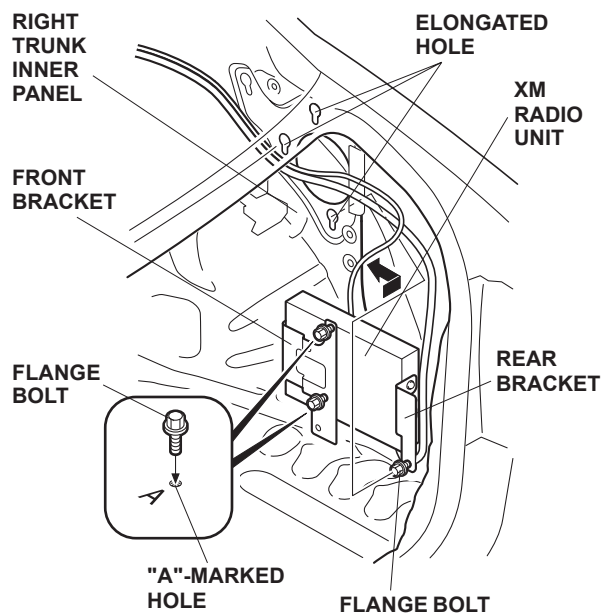

72. Place the XM radio assembly to the back of the right trunk inner panel. Set the three flange bolts into the elongated holes in the body panel.
73. Tighten the three flange bolts.

74. Using one wire tie with clip, secure the Bus and antenna cables in the area shown.

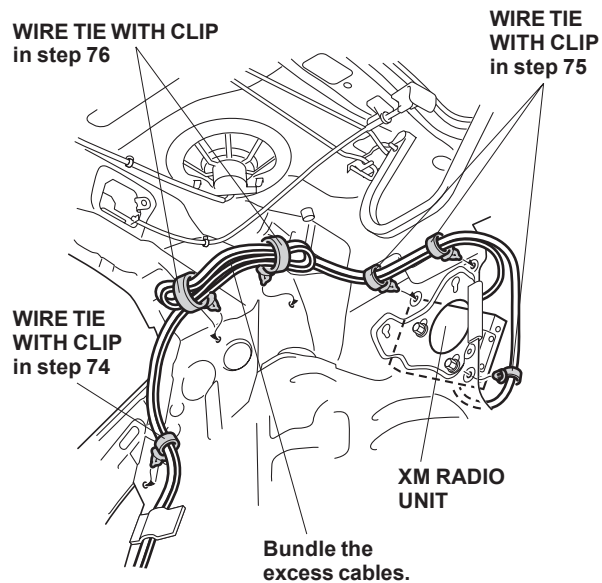

75. Using three wire ties with clip, secure the Bus and antenna cables to the holes on the right trunk inner panel.
76. Using two wire ties with clip, bundle the excess bus cable and antenna cables, then tighten securely. Go on to step 77.

**If the vehicle you're working on is equipped with a CD Changer, go to step 77; otherwise, go to step 79.**

77. Plug the 2-port Bus cable connectors in the two bus cables.

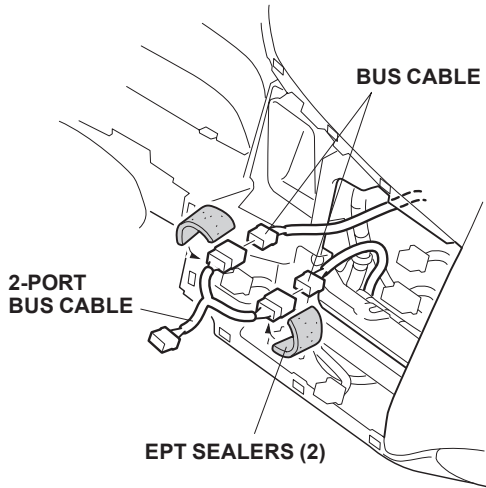

78. Attach two EPT sealers around the two plugged connectors.

79. Plug the bus cable connector into the audio unit.

#### Audio Unit for 4-door vehicle

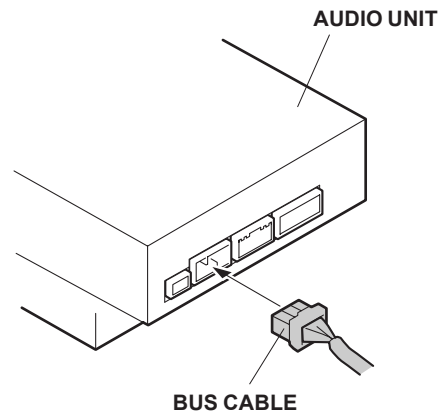

#### Audio Unit for 2-door vehicle

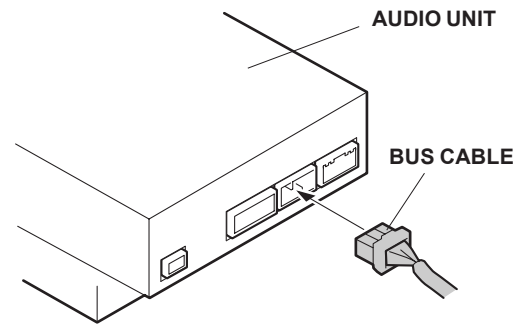

#### Navigation Unit

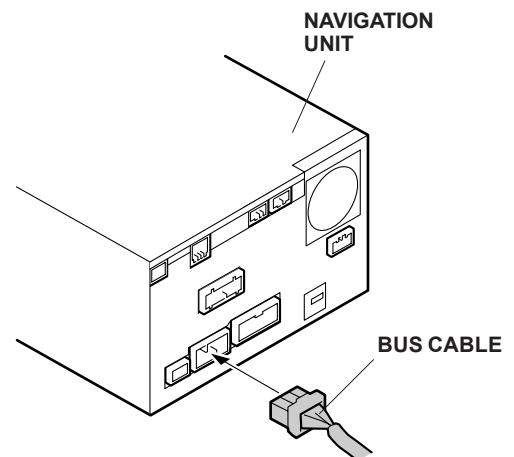

80. Connect the vehicle connectors to the center panel, and reinstall the center panel.

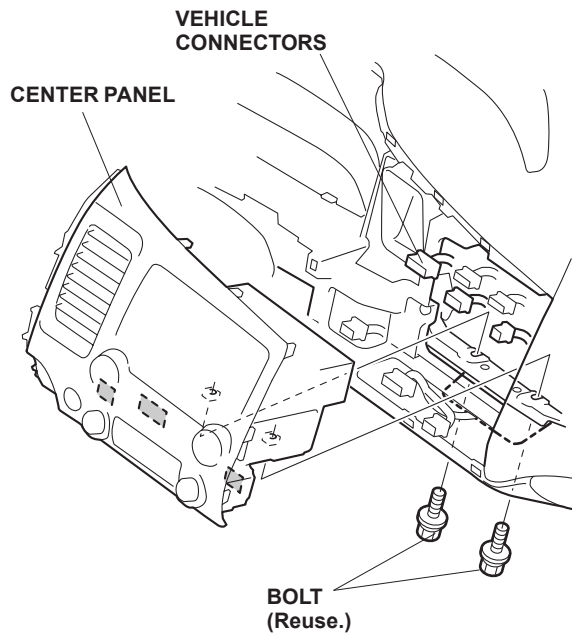

81. Replace the old clip on the right front pillar trim with a new one.

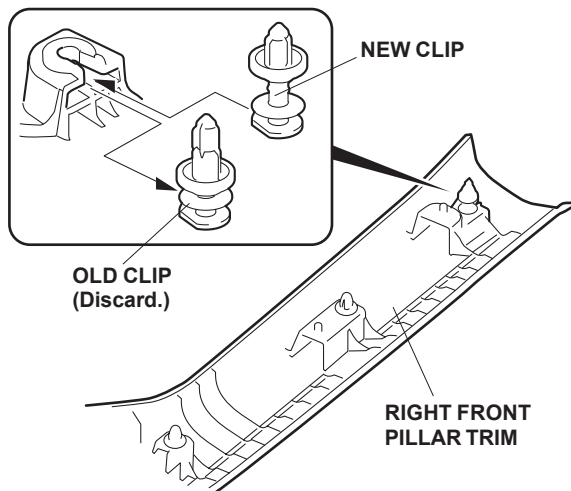

82. Check that all wire harnesses are routed properly and all connectors are plugged in.
83. Reconnect the negative cable to the battery.
84. Enter the customer's radio anti-theft code, and reset the radio station presets.
85. Set the clock.
86. Check the operation of the XM radio system according to the vehicle's Owner's Manual.
87. Reinstall all removed parts.