



INSTALLATION INSTRUCTIONS

Accessory

SECURITY SYSTEM (DX, VP)
P/N: 08E50-S5D-100F

Application

CIVIC
2 AND 4-DOOR

Publications No.

All 25459

Issue Date

SEP 2003

PARTS LIST

Security unit

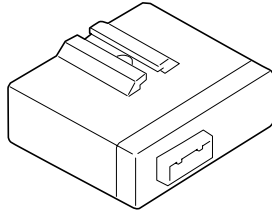

Window decal

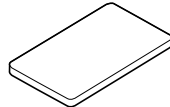

LED



Push nut



Owner's Manual



Bracket

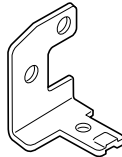

Harness

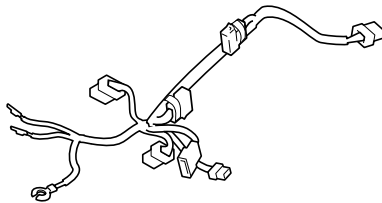

2-Pin connector (for LED)



Fuse, 2A



Fuse label

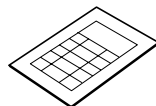

3 Cushion tapes

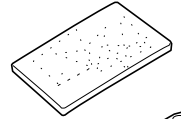

6 Long wire ties

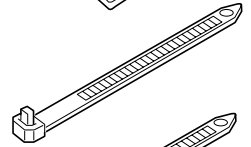

3 Short wire ties

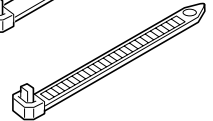

Ground bolt

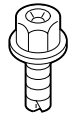

2 Transmitters



Keyless unit

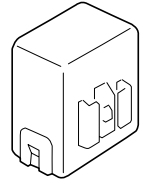

TOOLS AND SUPPLIES REQUIRED

Small flat-tip screwdriver

#2 Phillips screwdriver

Eye protection (face shield, safety goggles, etc.)

Center punch

Drill

5.5 mm Drill bit

File

Felt-tip pen

Ratchet

10 mm Socket

Tape measure

Diagonal cutters

Tape

Illustration of the Security System Installed on the Vehicle

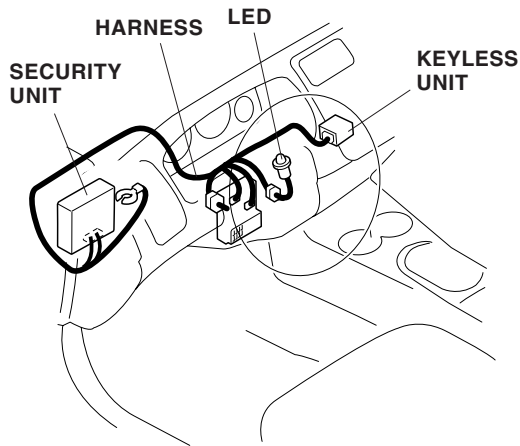

INSTALLATION

Customer Information: The information in this installation instruction is intended for use only by skilled technicians who have the proper tools, equipment, and training to correctly and safely add equipment to your vehicle. These procedures should not be attempted by “do-it-yourselfers.”

1. Make sure you have the anti-theft code for the radio, then write down the radio station presets.
2. Disconnect the negative cable from the battery.
3. Remove the dashboard lower cover on the driver's side of the vehicle. Turn the two knobs counterclockwise, and release the four retaining tabs.

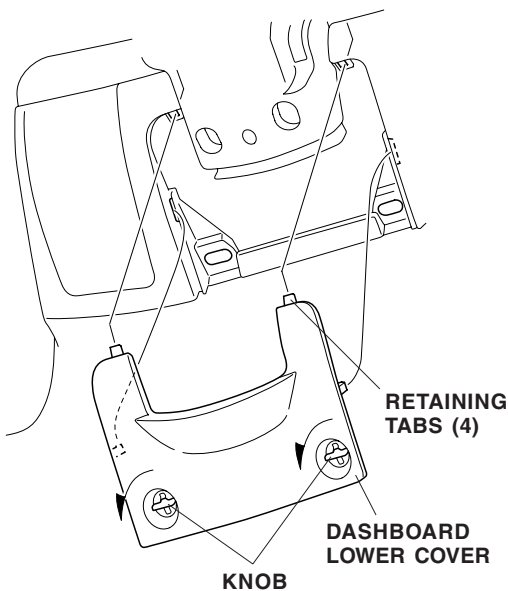

4. Remove the driver's dashboard under cover. Turn the knob counterclockwise, and release the two clips and one retaining tab.

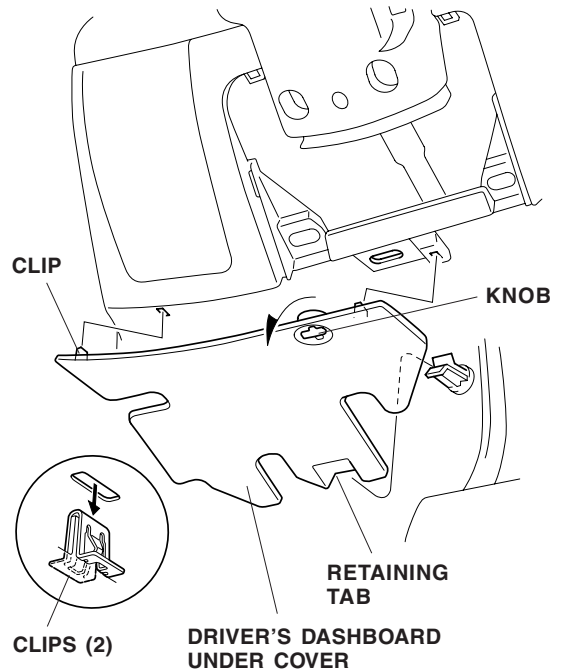

5. Remove the upper steering column cover (two self-tapping screws, one washer-screw and six retaining tabs).

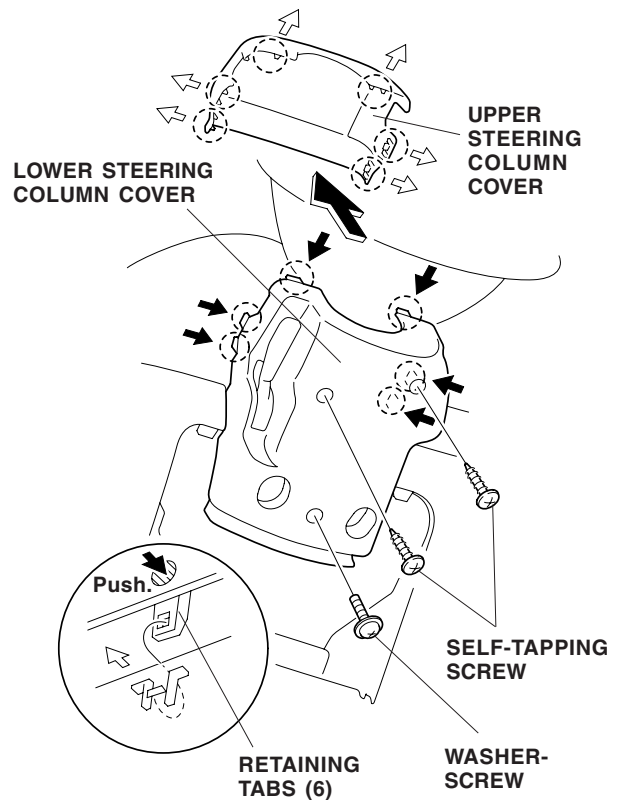

If the vehicle is equipped with a center console armrest, continue with step 6, otherwise, go to step 8.

6. Remove the escutcheon, and the center console trim:

A/T Model:

- Place the shift lever in the Neutral position.
- Pry up on the four retaining tabs and remove the escutcheon.
- Pry up on the three clips and six retaining tabs and remove the center console trim.

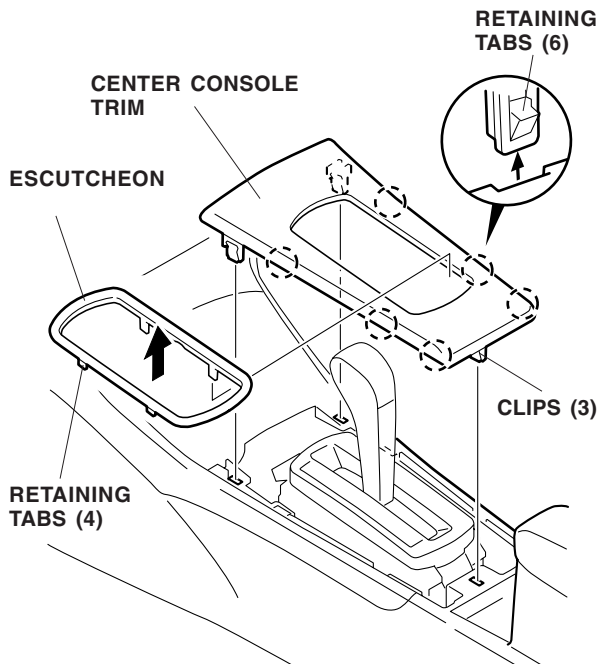

M/T Model:

- Remove the shift knob from the lever by holding the plastic section above the boot down firmly with one hand and turning the knob counterclockwise with the other hand.
- Pry up on the three clips and six retaining tabs and remove the center console trim.

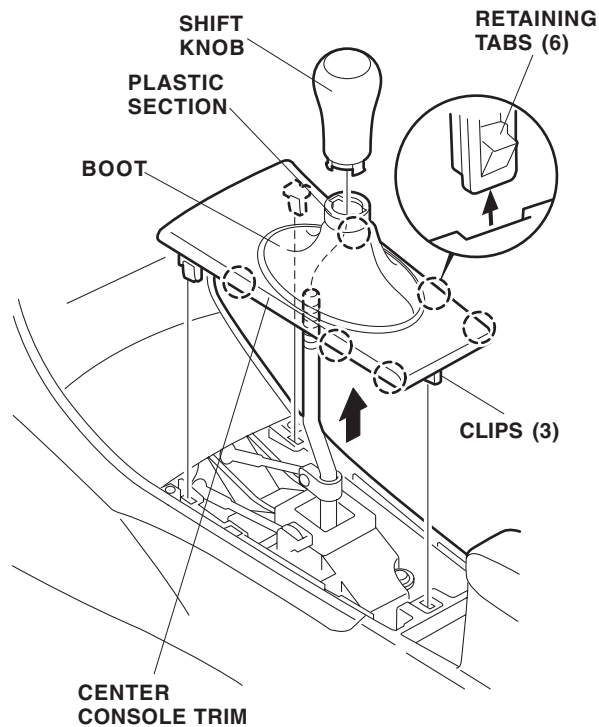

7. Remove the dashboard center lower cover.

Without a Cigarette Lighter and Ashtray:

- With the parking brake applied, place the gear shift lever in the Neutral position.
- Remove the two self-tapping screws fastening the dashboard center lower cover.
- Gently pry out on the dashboard center lower cover to release the rear four clips, then pull the cover rearward to release five clips and one retaining tab.
- Unplug the accessory power socket connector (If equipped, unplug the fog light harness), and remove the dashboard center lower cover.

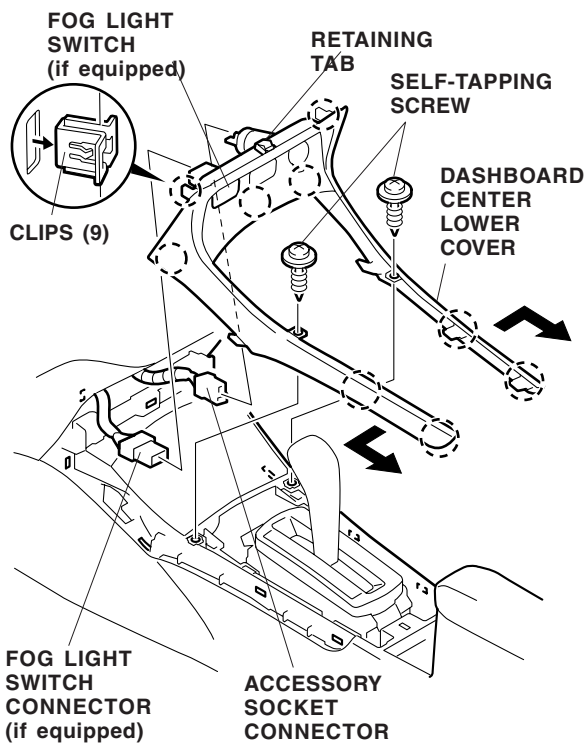

With a Cigarette Lighter and Ashtray:

- With the parking brake applied, place the gear shift lever in the Neutral position.
- Remove the ashtray. Inside the ashtray opening, remove the one self-tapping screw.
- Remove the two self-tapping screws fastening the dashboard center lower cover.
- Gently pry out on the dashboard center lower cover to release the rear four clips, then pull the cover rearward to release five clips and one retaining tab.
- Unplug the cigarette lighter connector, and illumination bulb, then remove the lower cover.

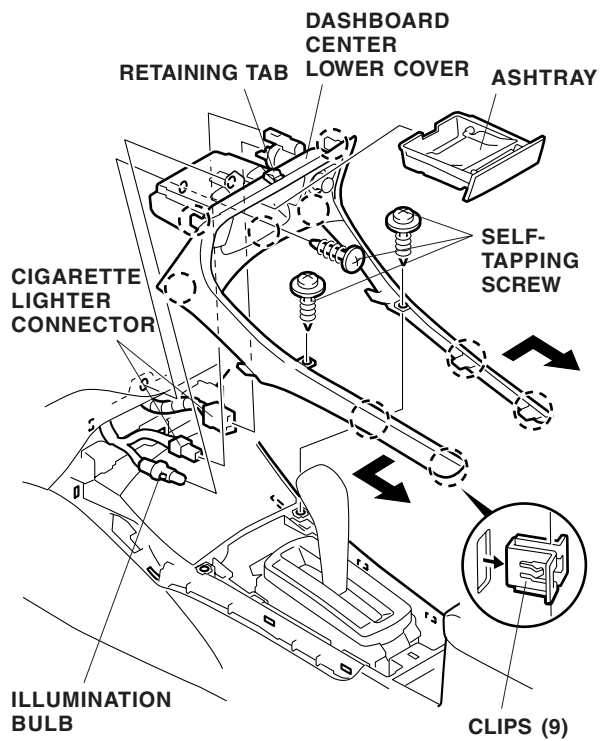

If the vehicle is not equipped with a center console armrest, continue with step 8, otherwise, go to step 10.

- Pull up on the parking brake lever, then remove the console box (nine clips).

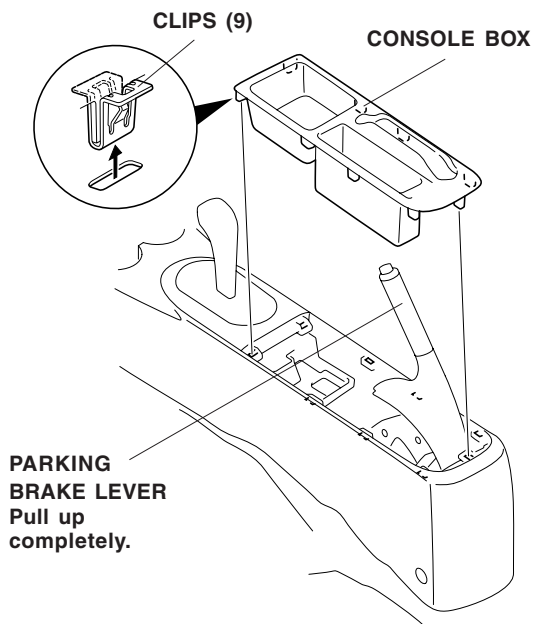

- Remove the center console.

A/T Model:

- Place the shift lever in the Neutral position.
- Remove the two self-tapping screws, two screws and two clips that fasten the center console and remove the console
- If equipped with an optional seat armrest, remove the console after reclining the seat-back.

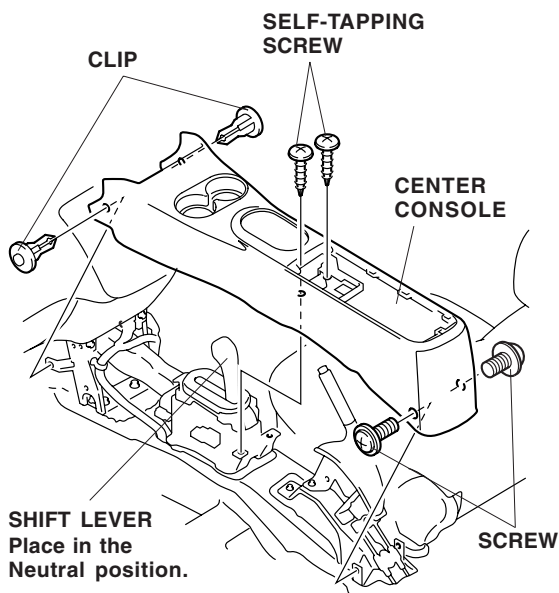

M/T Model:

- Remove the shift knob from the lever by holding the plastic section above the boot down firmly with one hand and turning the knob in a counterclockwise with the other hand.
- Remove the two self-tapping screws, two screws, and two clips that fasten the center console and remove the console.

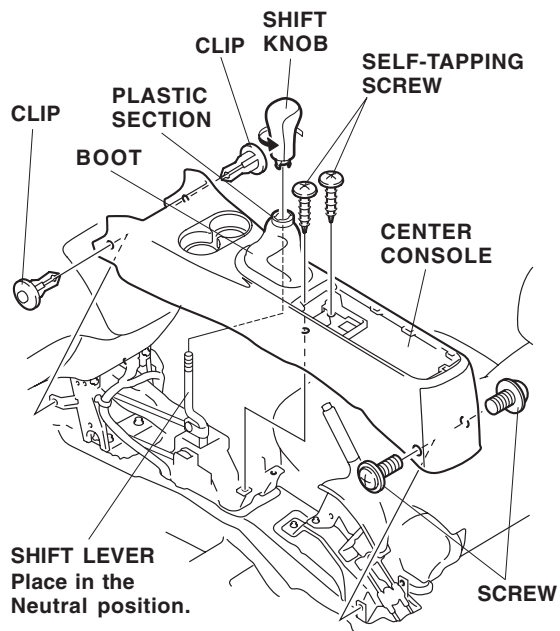

- Remove the dashboard center lower cover.

Without a Cigarette Lighter and Ashtray:

- With the parking brake applied, place the gear shift lever in the Neutral position.
- Gently pry out on the lower cover to release the six retaining clips.
- Unplug the accessory power socket connector (if equipped, unplug the fog light harness), and remove the lower cover.

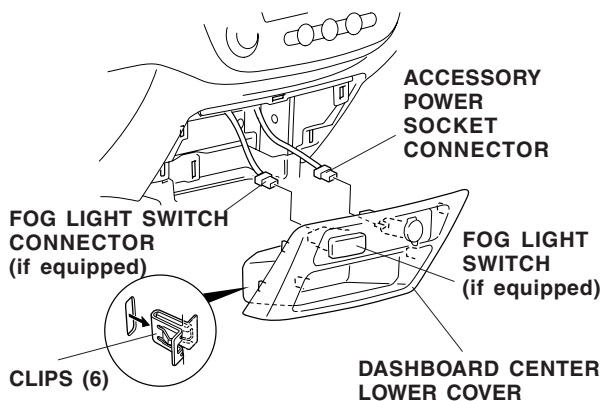

3620020K

With a Cigarette Lighter and Ashtray:

- With the parking brake applied, place the gear shift lever in the Neutral position.
- Remove the ashtray.
- Inside the ashtray opening, remove the one self-tapping screw securing the dashboard center lower cover.
- Gently pry out on the lower cover to release the six retaining clips.
- Unplug the cigarette lighter harness, and illumination bulb (if equipped, unplug the fog light harness), then remove the lower cover.

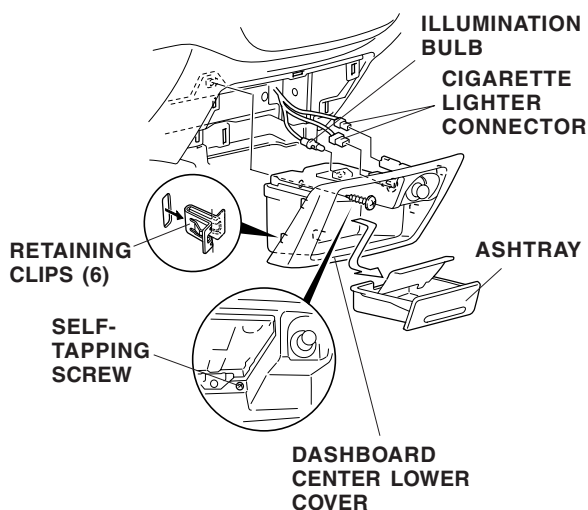

11. Route the 5-pin connector of the security system harness toward the right, and behind the dashboard.

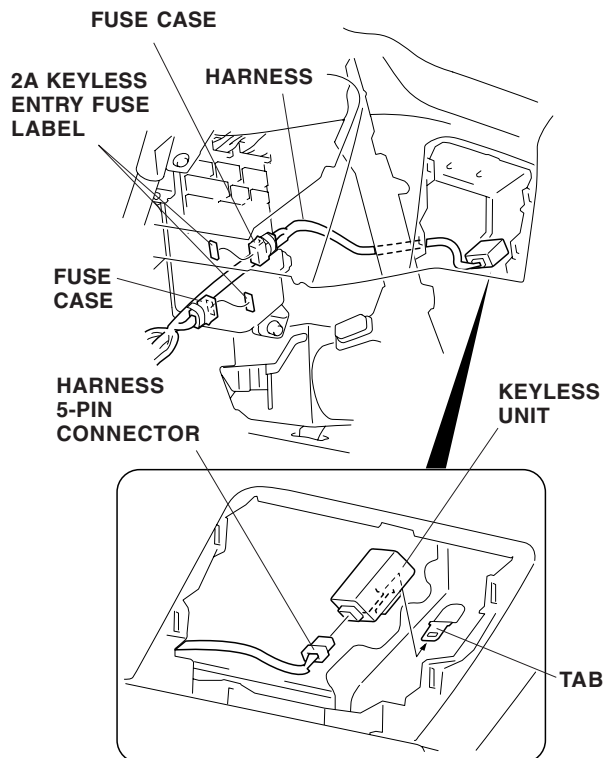

12. Attach the 2A keyless entry fuse labels to the fuse cases.
13. Plug the 5-pin connector of the security system harness into the keyless unit, then attach it to the tab on the console frame.

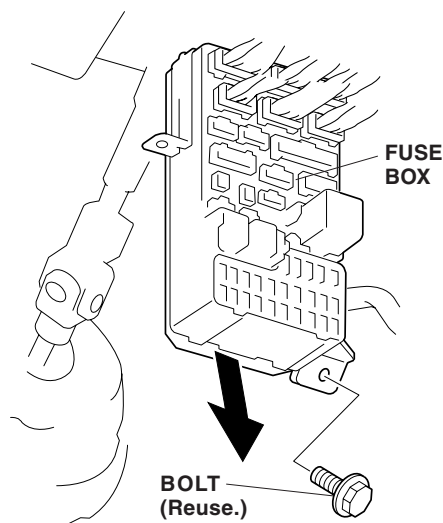

14. Remove the bolt that fastens the fuse box, and slide the fuse box down.

15. Install the 2A fuse into the No.15 slot of the fuse box.

NOTE: The No. 15 slot with the new 2 amp fuse controls the memory for the security system. In some vehicles, you may find a higher amp fuse already installed in the No. 15 slot. That fuse serves no purpose for this vehicle; remove it.

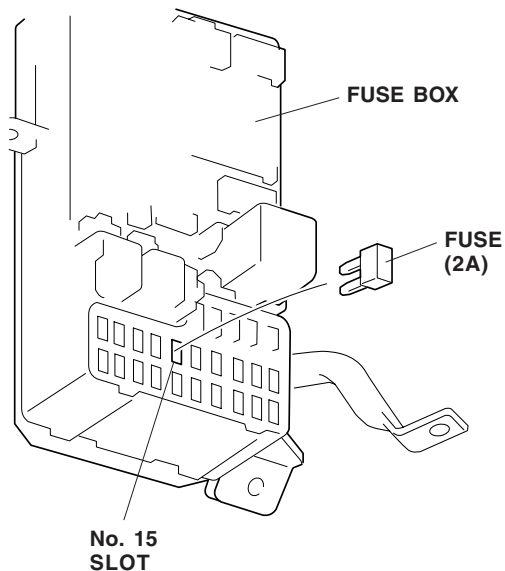

16. Unplug the vehicle 10-pin connector from the fuse box, and plug the 10-pin connector from security system harness into the fuse box. Plug the vehicle 10-pin connector into the remaining 10-pin security system harness connectors.

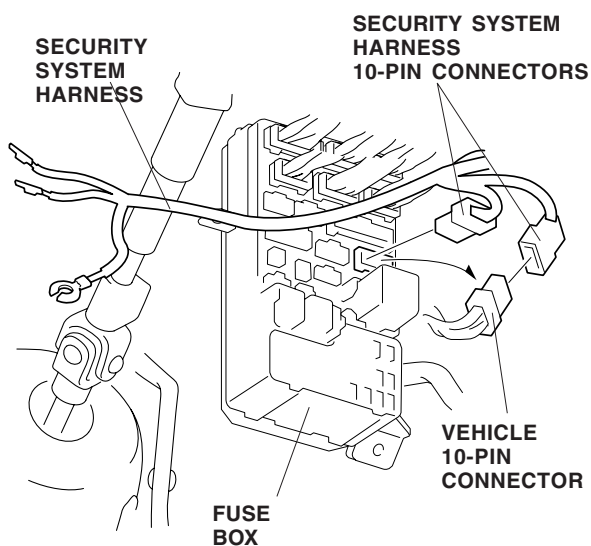

17. Reinstall the fuse box. Be careful not to pinch the harness.

18. Get the upper steering column cover removed in step 5. Measure and mark the inside of the upper steering column cover.

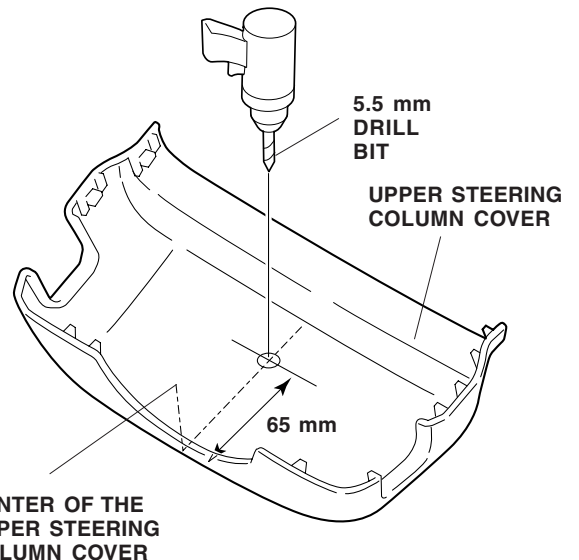

19. While wearing eye protection, lightly center-punch the mark, and drill a 5.5 mm hole through the center-punched mark. Remove all burrs.
20. Route the terminal ends of the LED through the hole you just drilled, and secure the LED with the push nut. Install the push nut securely.

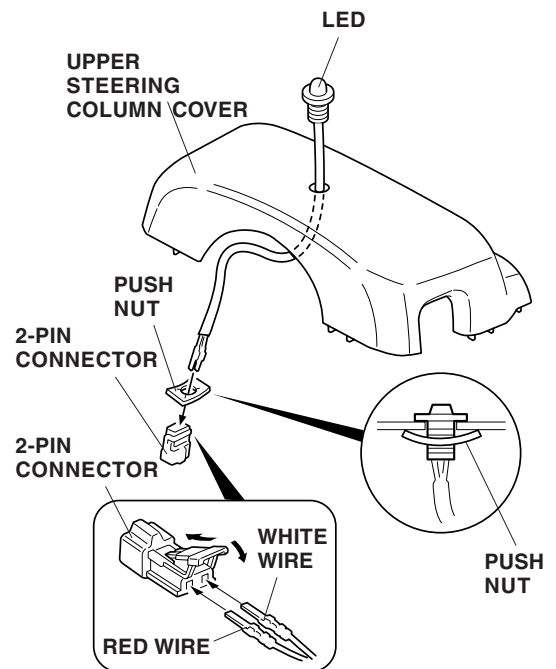

21. Get the 2-pin connector included in the kit. Firmly push the LED terminals into the 2-pin connector until they click into position, then lower the lock.

22. Install the bracket onto the security unit.

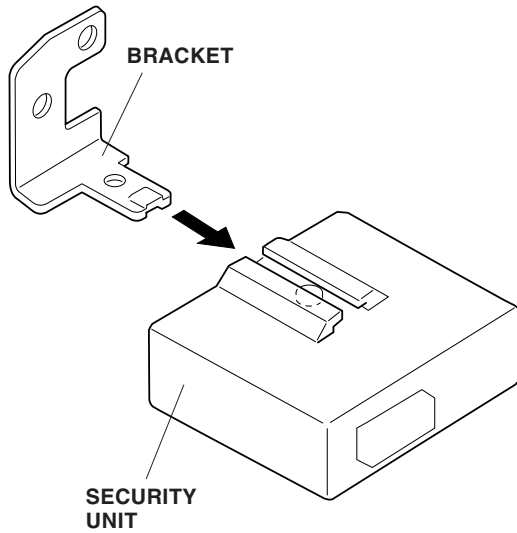

23. Route the ground terminal end off the security system harness under the dash, and over the steering column toward the driver's door.

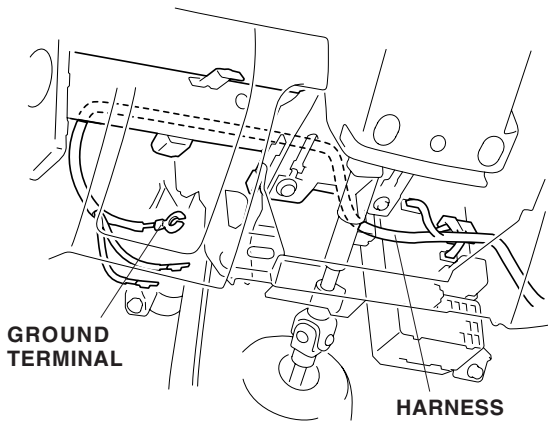

24. Behind the steering column bracket, locate the 16-pin connector blue-taped to the vehicle harness. Remove the tape to free the connector, pull the 16-pin connector down.

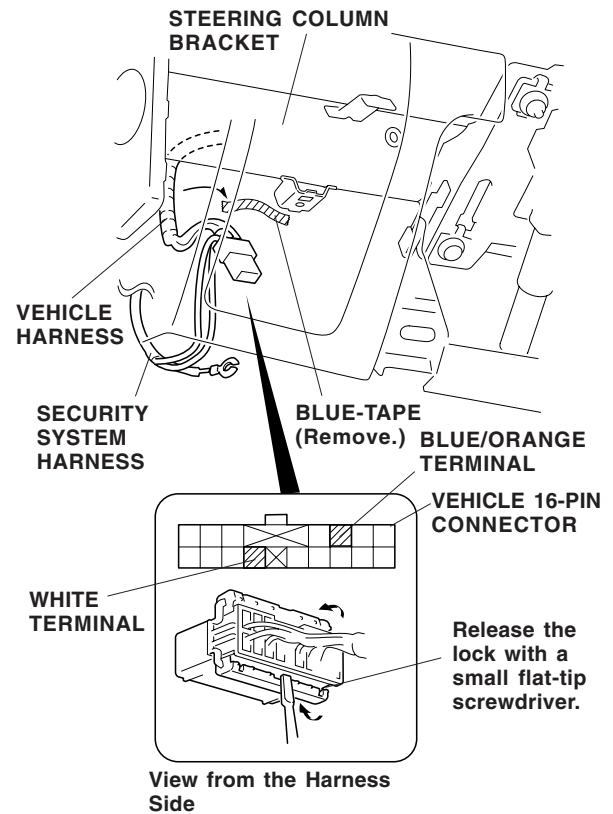

25. On the back of the 16-pin connector, use a small flat-tip screwdriver to release the lock. Insert the two terminals from the security system harness into the 16-pin connector in the locations shown. Reattach the lock to the connector.

26. Attach the security unit assembly and the ground terminal of the security system harness to the steering column bracket using the ground bolt from the kit.

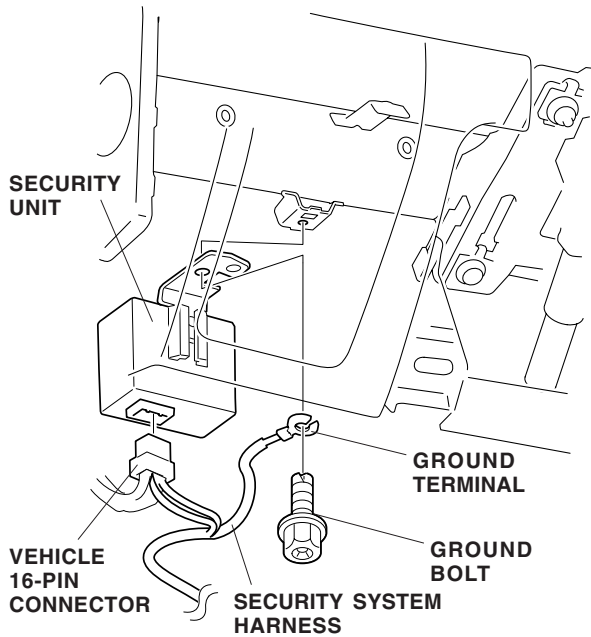

27. Position the upper steering column cover above the steering column, and plug the 2-pin connector of the security system harness into the 2-pin connector from the LED harness. Wrap one cushion tape around the connector.

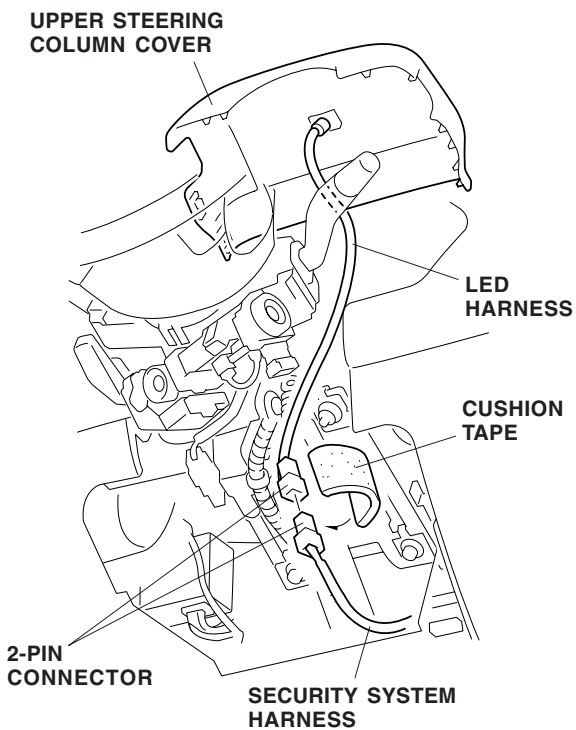

28. Secure the LED harness to the vehicle harness with the three short wire ties in the areas shown.

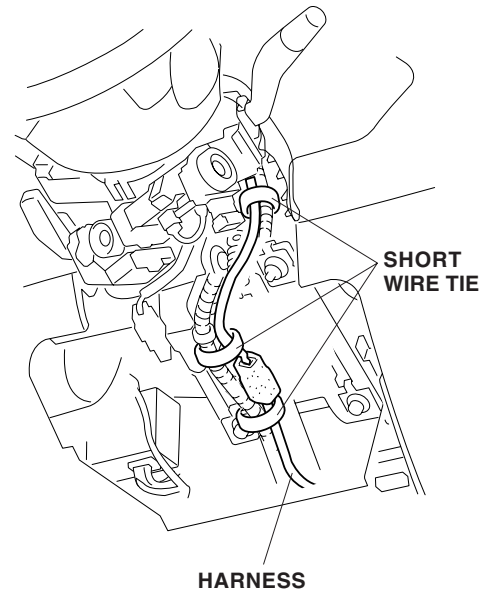

29. Under the dash, secure the security system harness to the vehicle harness with the three long wire ties in the areas shown.

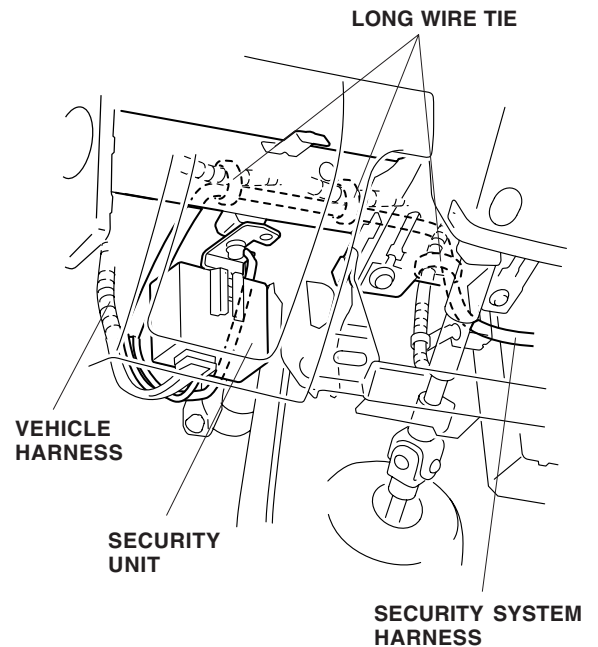

30. Continue to secure the security system harness to the vehicle harness with the two remaining long wire ties in the areas shown.

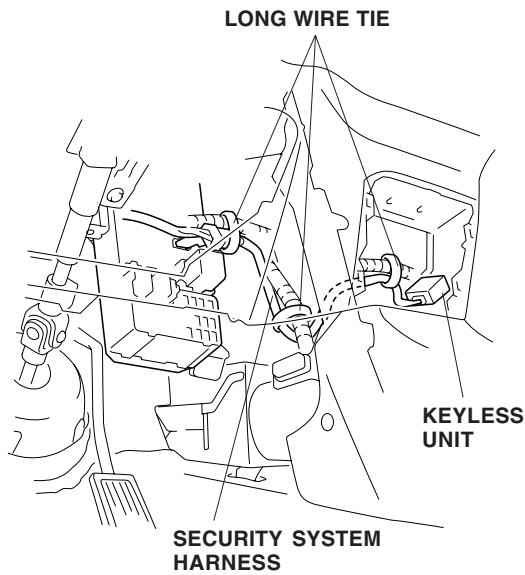

31. Attach the 2A "OPTION FUSE" fuse label over the No. 15 on the back of the dashboard lower cover.

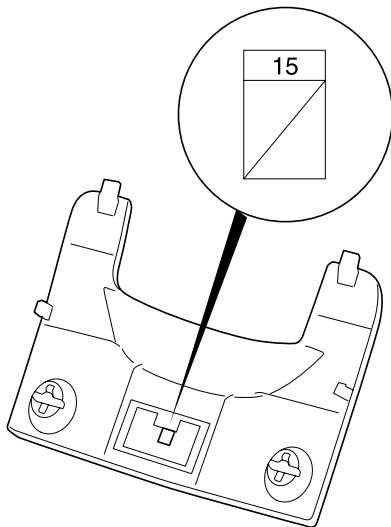

32. Check that all wire harnesses are routed properly and all connectors are plugged in.
33. Reinstall all removed parts.
34. Reconnect the negative cable to the battery, and reset the radio station presets.
35. Check the operation of the security system as described in the Owner's Manual provided in this kit.
36. Do the ECM/PCM idle learn procedure.

- Make sure all electrical items are turned off.
- Start the engine. Hold the engine speed at 3,000 rpm with no load (in Park or Neutral) until the radiator fan comes on.
- Let the engine idle for about 5 minutes with the throttle fully closed and with all electrical items off.

NOTE: If the radiator fan comes on during this step, the time it is operating must not be included in the 5 minutes.