 INSTALLATION INSTRUCTIONS	Accessory	Application	Publications No.
	CD CHANGER ATTACHMENT	2000 CIVIC 4-DOOR	All 20465
			Issue Date
			AUG 1999

PARTS LIST

CD Changer Attachment (sold separately):
P/N 08B12-S01-101

CD changer bracket

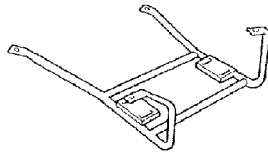

4 Spring nuts, 6 mm



4 Washer-bolts, 6 x 16 mm



4 Cushion tapes



3 Wire ties

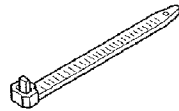

Right side bracket

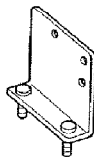

Left side bracket

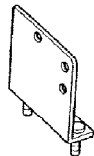

4 Flange nuts, 6 mm



BUS Cable

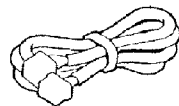

CD Changer Kit (sold separately):
P/N 08A06-181-420

CD Changer

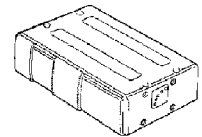

CD Magazine



Owner's Manual



4 Washer-screws, 4 x 6 mm



Adhesive seal sheet



Locking covers



TOOLS AND SUPPLIES REQUIRED

#2 Phillips screwdriver

10 mm Combination wrench

10 mm Socket

Ratchet

Diagonal cutters

Flat-tip screwdriver

Felt-tip pen

Scissors

Small flat-tip screwdriver

Illustration of the CD Changer Installed on the Vehicle

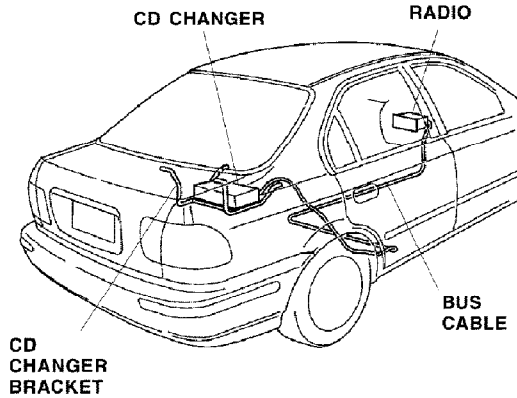

INSTALLATION

Customer Information: The information in this installation instruction is intended for use only by skilled technicians who have the proper tools, equipment, and training to correctly and safely add equipment to your car. These procedures should not be attempted by "do-it-yourselfers."

1. Make sure you have the anti-theft code for the radio, then write down the frequencies for the preset buttons.
2. Disconnect the negative cable from the battery.
3. Remove the rear console.
 - *Without a front armrest:* Remove the two self-tapping screws, and release the two retaining tabs.

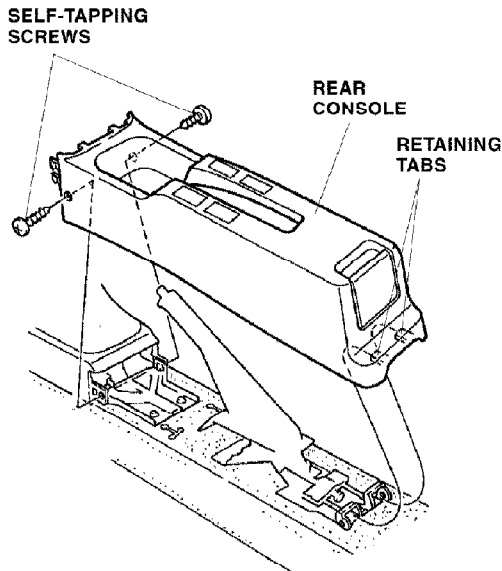

- *With a front armrest:* Remove the four self-tapping screws.

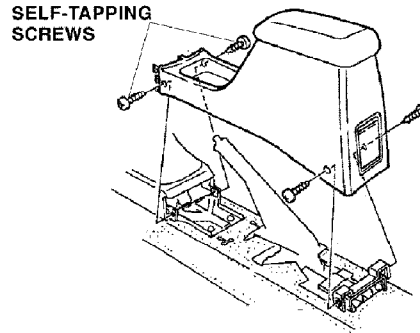

4. Remove the front console (four self-tapping screws).

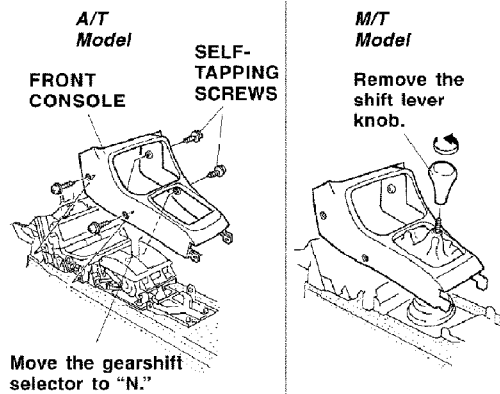

5. Remove the driver's dashboard lower cover (three self-tapping screws, three clips, and pull), then disconnect the connector(s).

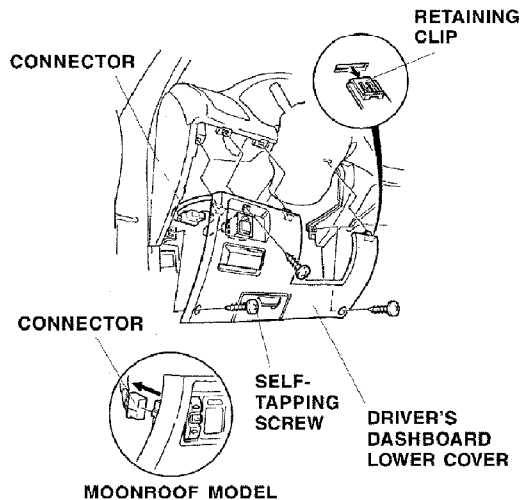

6. Remove the glove box (two bolts).

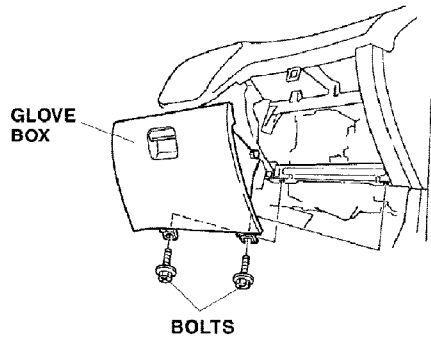

7. Remove the center dashboard lower cover (five self-tapping screws, one bolt, and one connector).

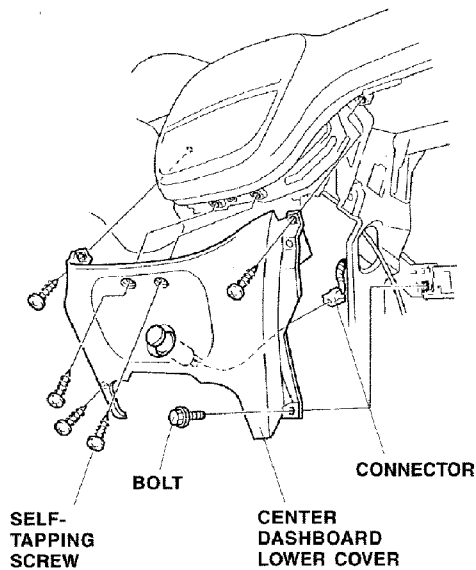

8. Remove the rear seat cushion (one bolt, and lift the rear of the cushion).

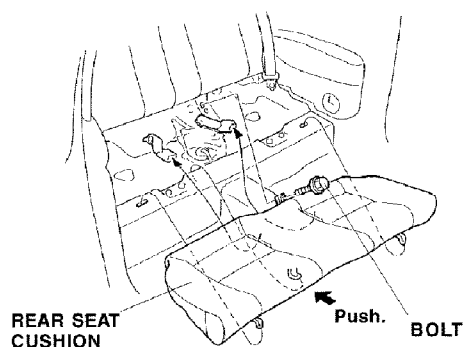

Routing the BUS Cable

9. Plug the BUS cable connector into the radio. Plug the vehicle 20-pin connector, and the antenna lead into the back of the radio/cassette player.

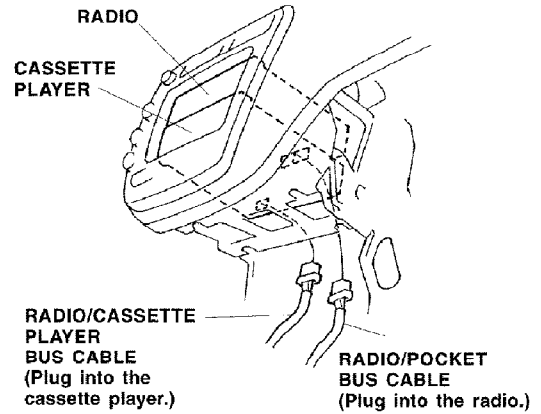

Radio with Pocket:

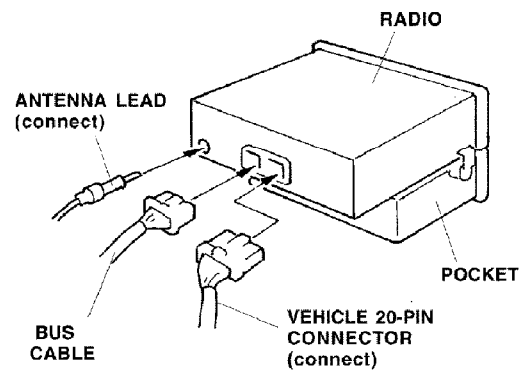

Radio with Cassette Player:

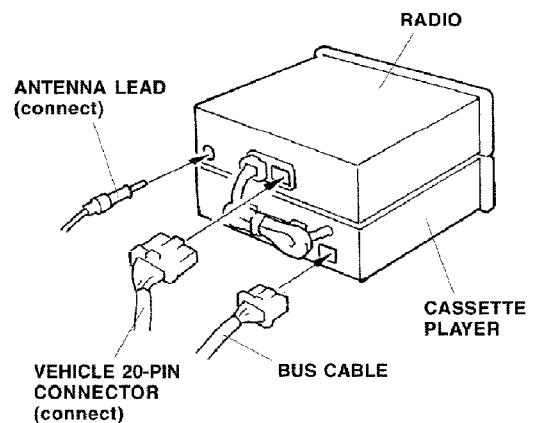

10. Using scissors, cut a 50 mm slit in the floor carpet in the area shown. Do not damage the vehicle harness when cutting the floor carpet.

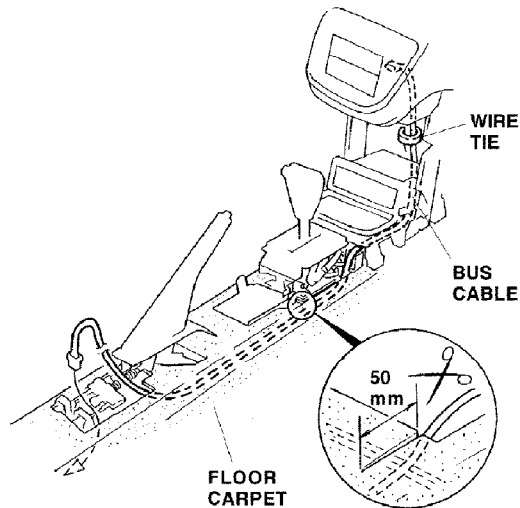

11. Route the BUS cable under the floor carpet toward the rear of the vehicle.
12. Secure the BUS cable to the vehicle harness with one wire tie.
13. Cut a cushion tape in half, and secure the BUS cable to the floor panel with the two pieces of cushion tape in the areas shown.

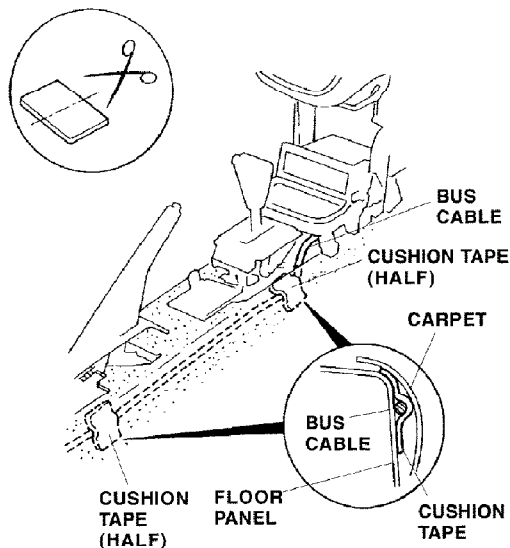

14. Remove the right seat side bolster (one bolt, and lift up).

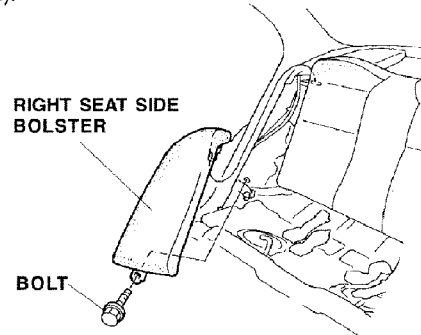

15. Remove the two clips, turn over the carpet, and route the BUS cable toward the rear of the vehicle.

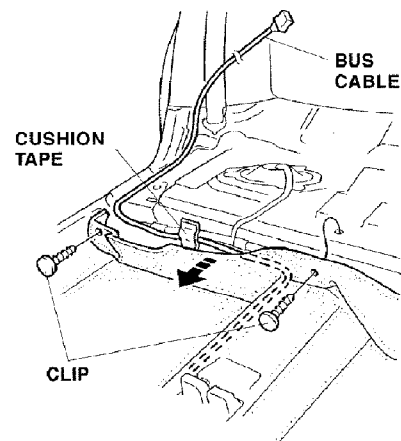

16. Secure the BUS cable to the floor panel with one cushion tape in the areas shown.
17. Route the BUS cable up the wheelwell and behind the seat belt retractor, and secure the BUS cable to the wheelwell area with two cushion tapes.

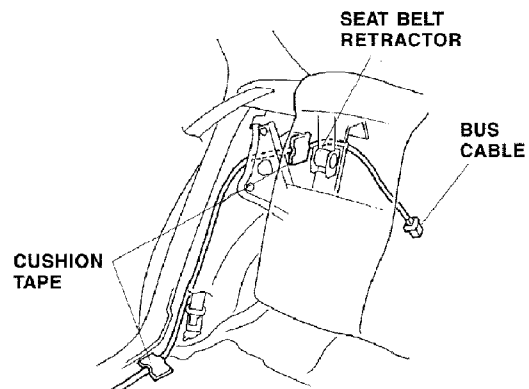

Installing the CD Changer

- Carefully unpack the CD changer. Remove the three shipping screws, and discard the shipping cover. Save the shipping screws for your customer in the event the unit needs to be serviced.
- Install an adhesive seal (included in the CD Changer Kit) over each of the three shipping screw holes.

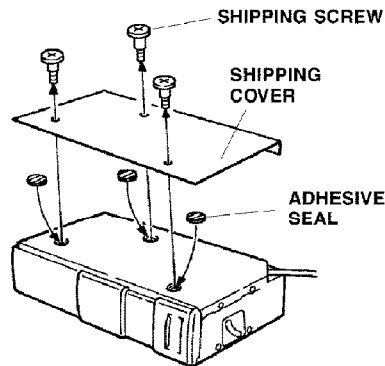

- Visually check the position of the spring adjusting pins on both sides of the CD changer. If both of the spring adjusting pins are not in the horizontal (H) position, move the pins to the horizontal (H) position with a small flat-tip screwdriver.

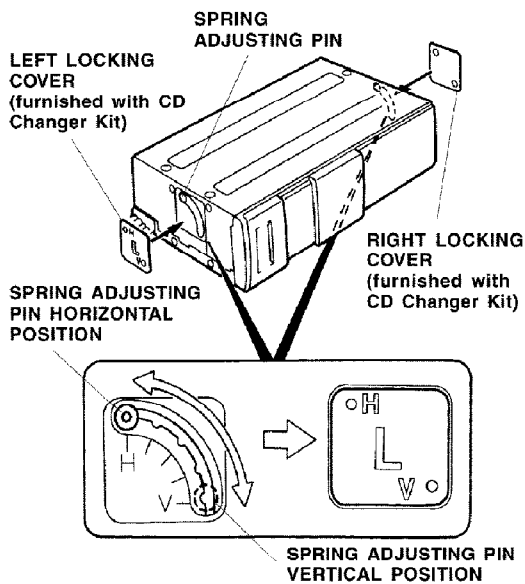

- Remove the adhesive backings from the "L" and "R" locking covers, and attach them to the side of the CD changer. Align the two diagonally opposite holes with the H and V positions.

- Inside the trunk, locate the four square holes in the metal rear parcel shelf. Slide a spring nut onto the metal rear parcel shelf through each of the four square holes. Note the direction of the spring nuts.

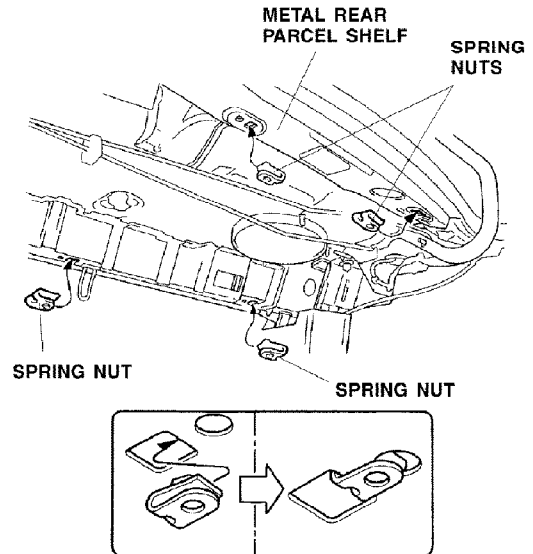

- Position the CD changer bracket on the spring nuts you just installed, then install four 6 x 16 washer-bolts. Tighten the bolts securely.

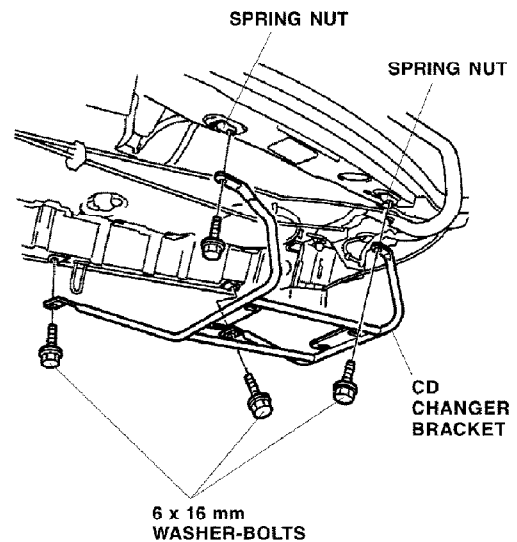

24. Position the side brackets on the CD changer, and install the four 4 x 6 mm washer-screws supplied with the CD Changer Kit. Note the direction of the side brackets. The extra hole in each of the brackets should face the front of the CD changer. Tighten the washer-screws securely.

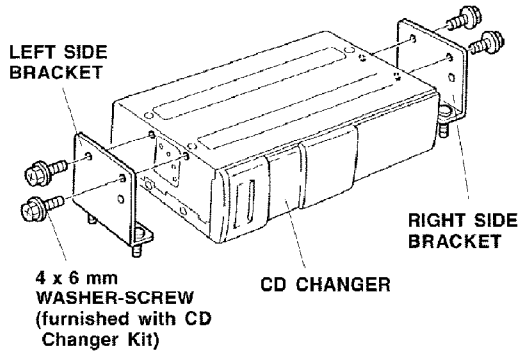

25. Position the CD changer on the bracket, then install four 6 mm flange nuts. Tighten the flange nuts securely.

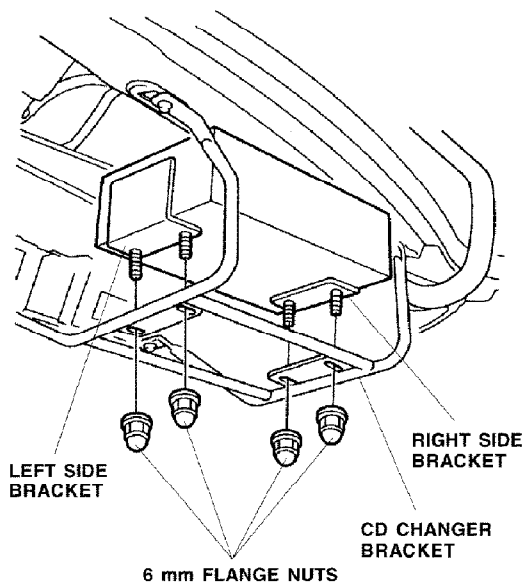

26. Connect the BUS cable to the connector from the CD changer.
27. Fold the excess BUS cable several times, and secure it to the rear of the CD changer bracket with two wire ties.

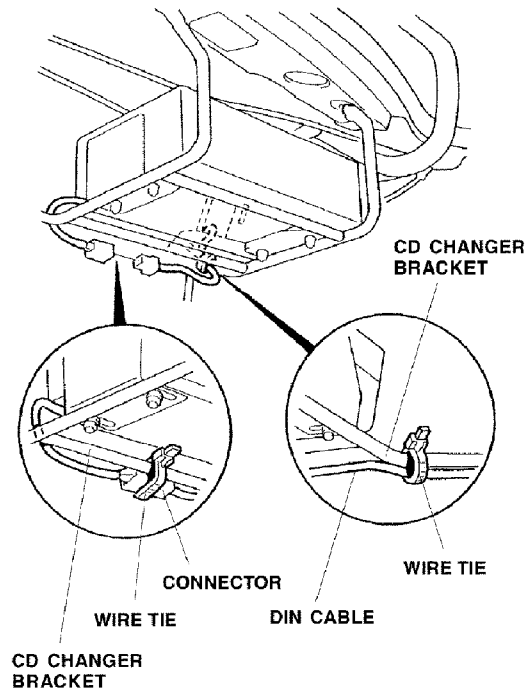

28. Secure the BUS cable to the arm of the bracket with one wire tie.
29. Check that all wire harnesses are routed properly and all connectors are plugged in.
30. Reconnect the negative cable to the battery.
31. Reset the clock and the radio station presets.
32. Check the operation of the CD changer as described in the Owner's Manual supplied.
33. Reinstall all removed parts.
34. Put the CD changer Owner's Manual and the shipping screws (removed in step 18) in the glove box for your customer.