



INSTALLATION INSTRUCTIONS

Accessory	Application	Publications No.
CD/CASSETTE PLAYER/ IN-DASH CD CHANGER	2000 CIVIC 2/3/4-DOOR	All 20434
		Issue Date AUG 1999

PARTS LIST

CD Player:
P/N 08A06-1A1-050

— or —

Cassette Player:
P/N 08A03-581-111

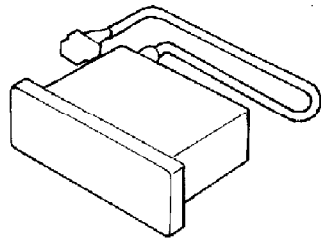

7 Washer-bolts



Owner's Manual



Wire tie

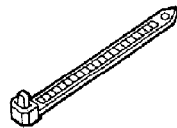

Clip

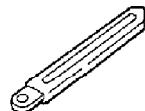

In-Dash CD Changer: P/N 08A06-3B1-300

In-dash CD changer

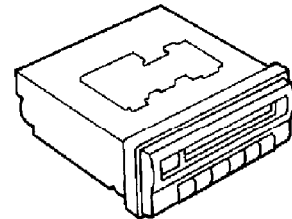

Owner's Manual



6 Washer-screws
(5 x 8 mm)



Washer-screw
(4 x 6 mm)



Wire tie (not used)

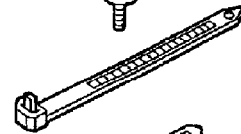

Clip

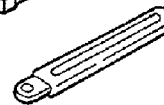

Adhesive strips

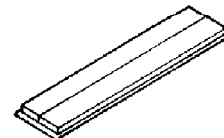

TOOLS REQUIRED

#2 Phillips screwdriver

10 mm Socket

Ratchet

INSTALLATION

Customer Information: The information in this installation instruction is intended for use only by skilled technicians who have the proper tools, equipment, and training to correctly and safely add equipment to your car. These procedures should not be attempted by "do-it-yourselfers."

NOTE: On the CX model, a Genuine Honda radio (P/N 08A04-1A1-300) is required to operate the CD/cassette player. The radio is sold separately.

1. Write down the frequencies for the radio station presets.
2. Disconnect the negative cable from the battery.
3. Remove the driver's dashboard lower cover:
 - Remove the three screws.
 - Gently pull along the top to release the three retaining clips.
 - Unplug the connector(s) and remove the cover.

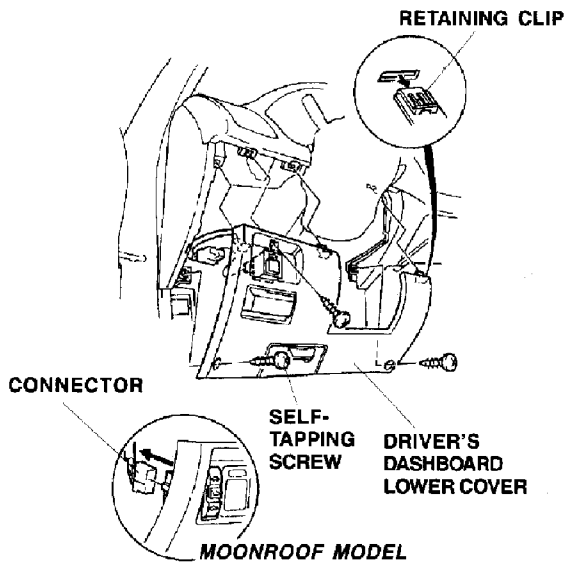

4. Remove the glove box (two bolts).

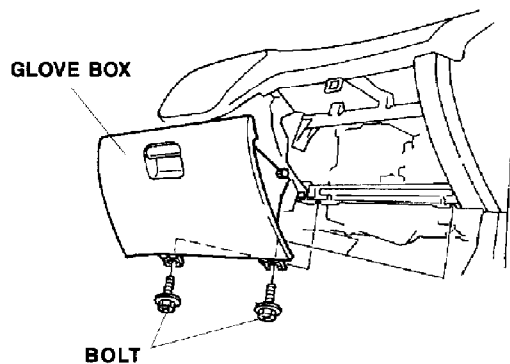

5. Remove the center dashboard lower cover (five self-tapping screws, one bolt, and one connector).

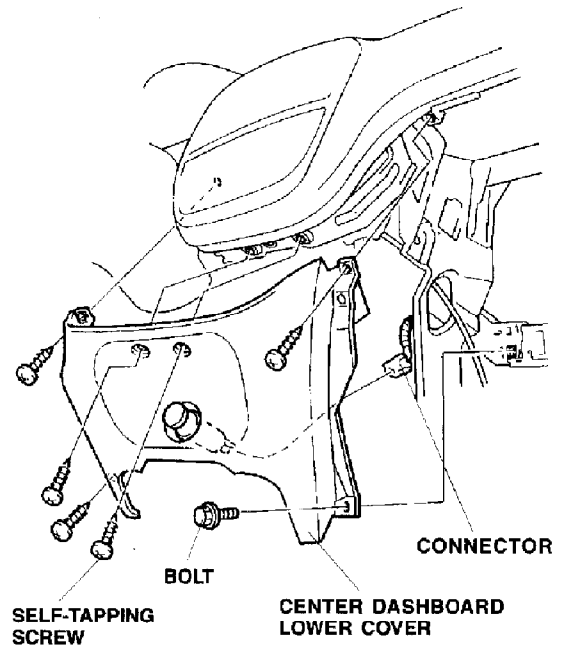

6. Remove the four bolts from under the radio bracket.

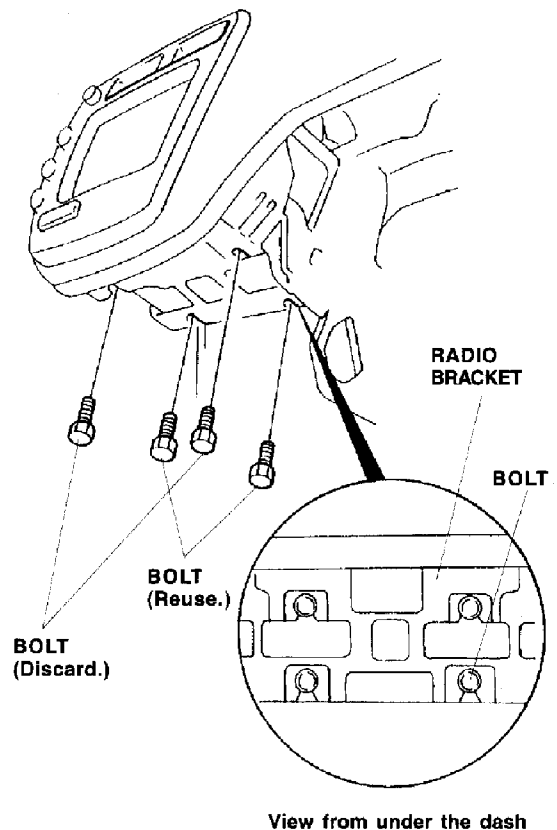

7. From under the instrument panel, unplug the two vehicle connectors for the A/C controller.

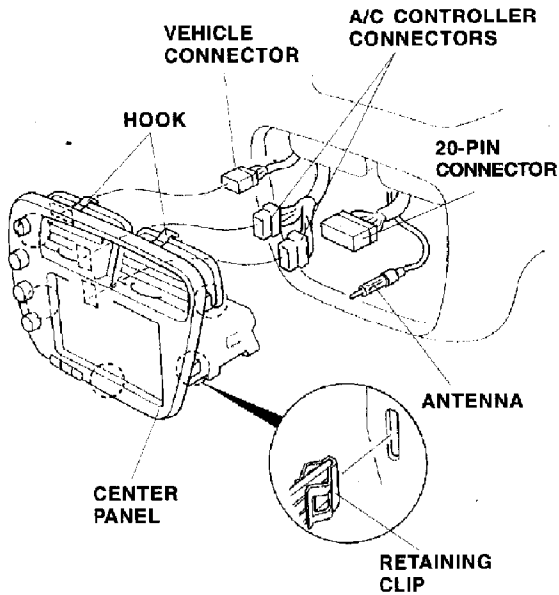

8. Remove the center panel (release the five clips and two hooks, pull the center panel out, unplug the radio connector and antenna lead, and unplug the vehicle connector).
9. Remove the A/C controller from the center panel (three screws and one connector).

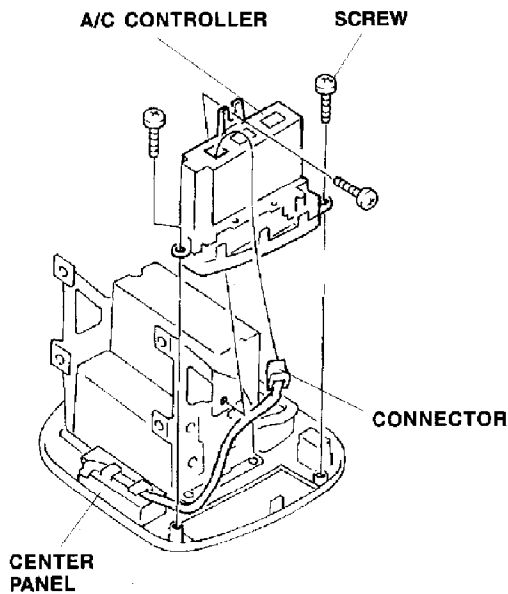

10. Remove the radio assembly from the center panel (four washer-bolts).

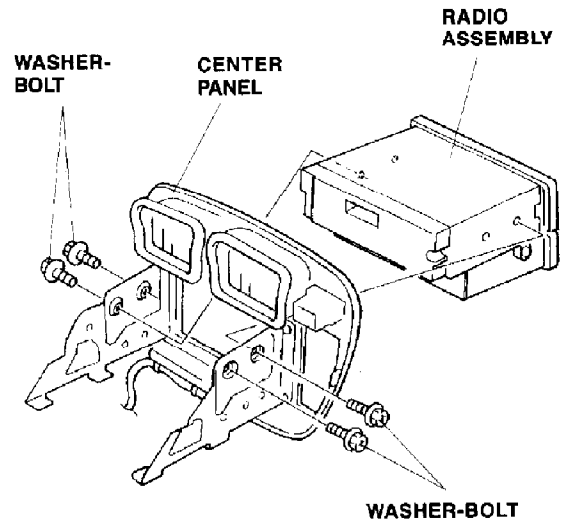

11. Remove the pocket from the radio (two self-tapping screws).

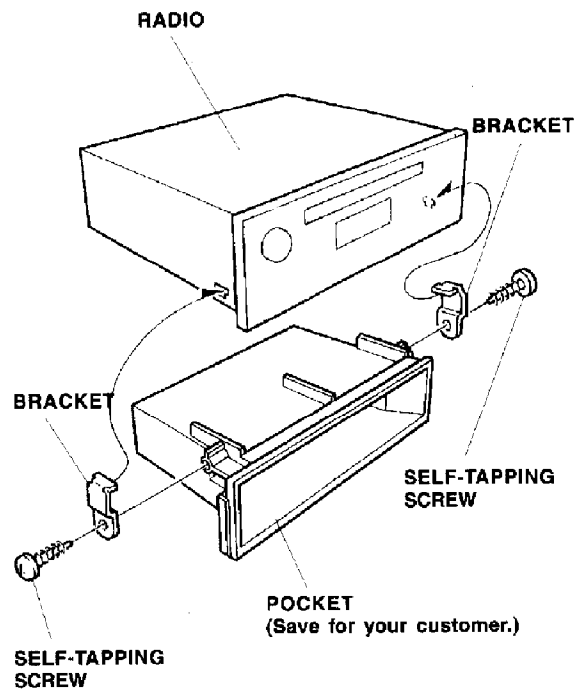

12. For in-dash CD changer installation: While wearing gloves, lift up and remove the shipping cover and label. Remove one adhesive strip, and attach it to the bottom edge of the changer. Discard the shipping cover, the label, and the other adhesive strip.

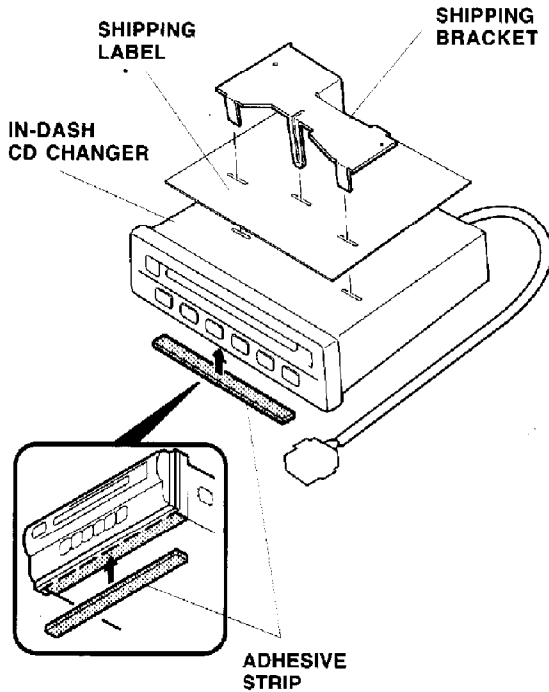

13. Place the radio onto the CD/cassette player or in-dash CD changer.

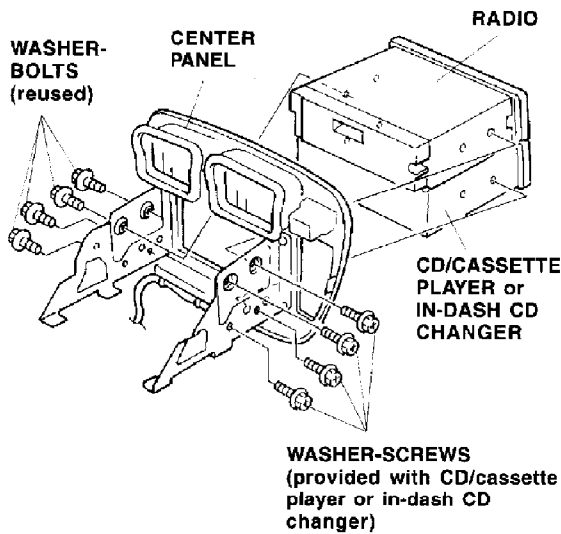

14. Slide the radio assembly into the center panel. Install the four washer-bolts you removed from the radio in step 10, and four of the washer-screws provided with the CD/cassette player or in-dash CD changer.

15. Install the clip to the CD/cassette player or in-dash CD changer with one washer-bolt, and plug the connector into the back of the radio.

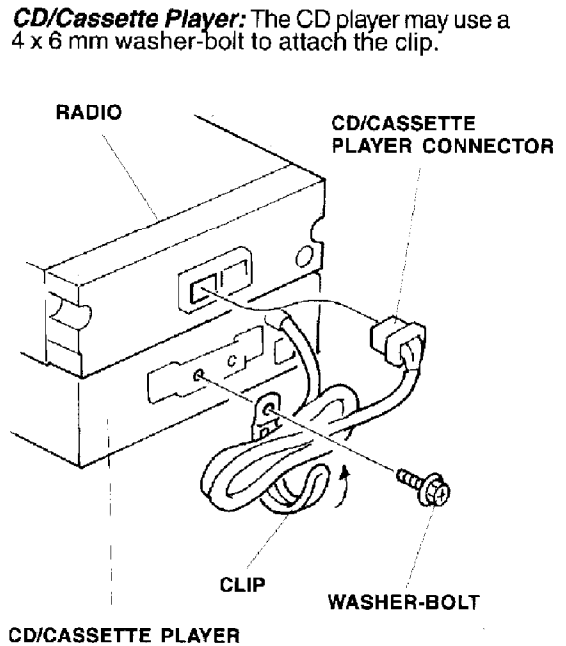

- In-Dash CD Changer:* Use the 4 x 8 mm washer-bolt.

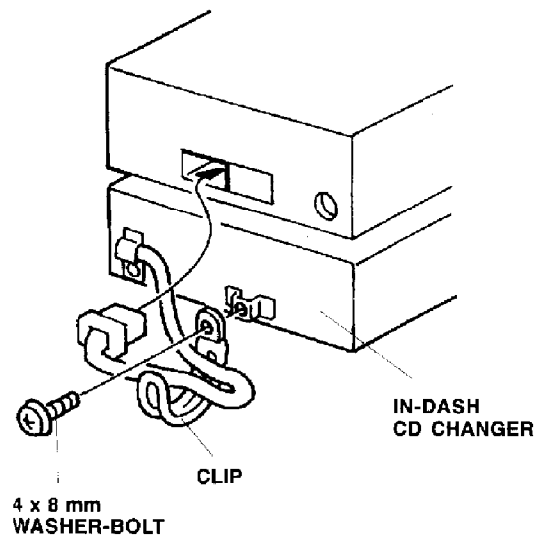

17. Fold the excess length of the cable, and secure it with the clip.

18. Reinstall the A/C controller onto the center panel.
19. Reinstall the center panel:
 - Plug the radio connector and the antenna lead into the radio. Plug the vehicle connector into the center panel.
 - Carefully slide the center panel back into the instrument panel. Install the two 5 x 8 mm washer-screws provided with the CD/cassette player or in-dash CD changer, and reuse the two bolts you removed in step 6.
 - From under the instrument panel, reconnect the two connectors to the A/C controller.

20. Reconnect the negative cable to the battery.
21. Check the operation of the CD/cassette player or in-dash CD changer described in the Owner's Manual supplied with each unit.
22. Reinstall the glove box, the center dashboard lower cover, and the driver's lower dashboard cover.
23. Reset the clock and the radio station presets.
24. Put the CD/cassette player or in-dash CD changer Owner's Manual and the pocket (removed in step 11) in the glove box.

