



# INSTALLATION INSTRUCTIONS

Accessory

**REMOTE ENGINE STARTER SYSTEM**

Application

**2008 CIVIC 2-DOOR (A/T ONLY)**

Publications No.

**All 38215-38958**

Issue Date

**FEB 2008**

## PARTS LIST

**Remote Engine Starter Unit Kit  
P/N 08E91-E22-100B**

Transmitter

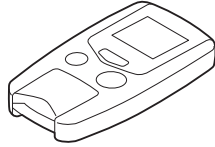

Control unit

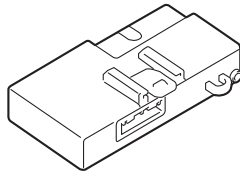

Antenna

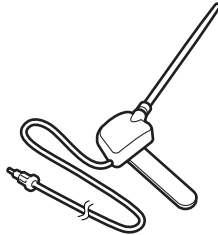

Key ring



Protective tape



Engine starter label



Fuse label

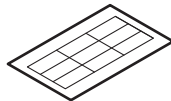

Accessory User's Information Manual

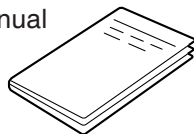

Quick Start Guide

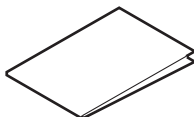

**Remote Engine Starter Attachment Kit  
P/N 08E92-SNA-100B**

Engine starter harness

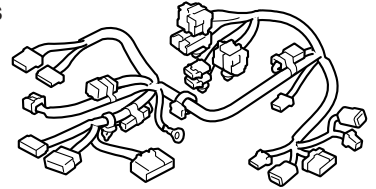

Control unit bracket

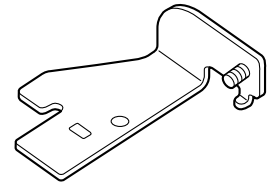

Relay bracket

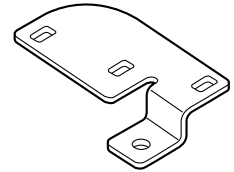

3 Black relays (4-pin)

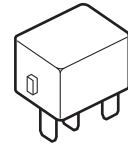

18 Wire ties

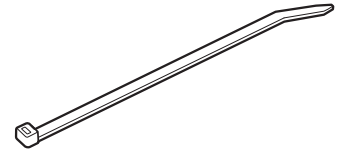

7 Foam cushion tapes

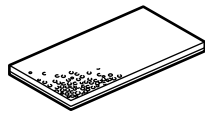

Flange nut



Clip



Green relay (5-pin)

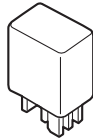

Template

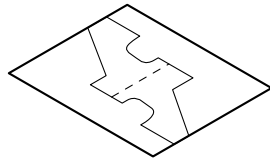

### Illustration of the Engine Starter System Installed on the Vehicle

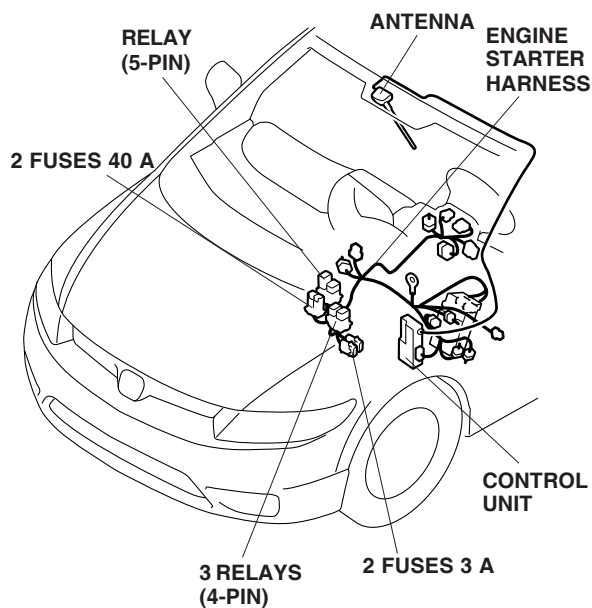

### TOOLS AND SUPPLIES REQUIRED

- Phillips screwdriver
- Long blade flat-tip screwdriver
- Small flat-tip screwdriver
- 6 mm Hex wrench
- T25 Torx bit
- 3 mm and 7 mm Drill bit
- File
- Ratchet
- 10 mm Socket
- Combination wrench
- Isopropyl alcohol
- Shop towel
- Tape measure
- Clip remover
- Diagonal cutters
- Felt-tip pen
- Center punch
- Scissors
- 2 Pairs of needle nose pliers
- Rubber mallet
- HDS (Honda Diagnostic System)
- Masking tape
- Safety goggles

### INSTALLATION

**Customer Information:** The information in this installation instruction is intended for use only by skilled technicians who have the proper tools, equipment, and training to correctly and safely add equipment to your vehicle. These procedures should not be attempted by "do-it-yourselfers."

NOTE: The antenna should only be installed if the ambient air temperature 15°C (60°F) or above.

1. Make sure you have the anti-theft code for the radio, then write down the radio station presets.
2. Disconnect the negative cable from the battery.

### Setting the Control Unit

- Get the control unit. Using a small flat-tip screwdriver, adjust the switches on the control unit to the locations shown. Using an isopropyl alcohol on a shop towel, clean the area where the protective tape will attach. Attach the protective tape to the control unit over the switches.

**NOTE:**

- The switches must be selected before the control unit is plugged in.
- If the switch setting is not correct, the engine starter will not operate correctly.
- If setting the switches when the control unit is installed in the vehicle, touch a metal part of the screwdriver to a metal part of the vehicle to discharge any static electricity.
- If you change the switch settings with the unit connected, you must disconnect the unit then reconnect it before the settings will change.

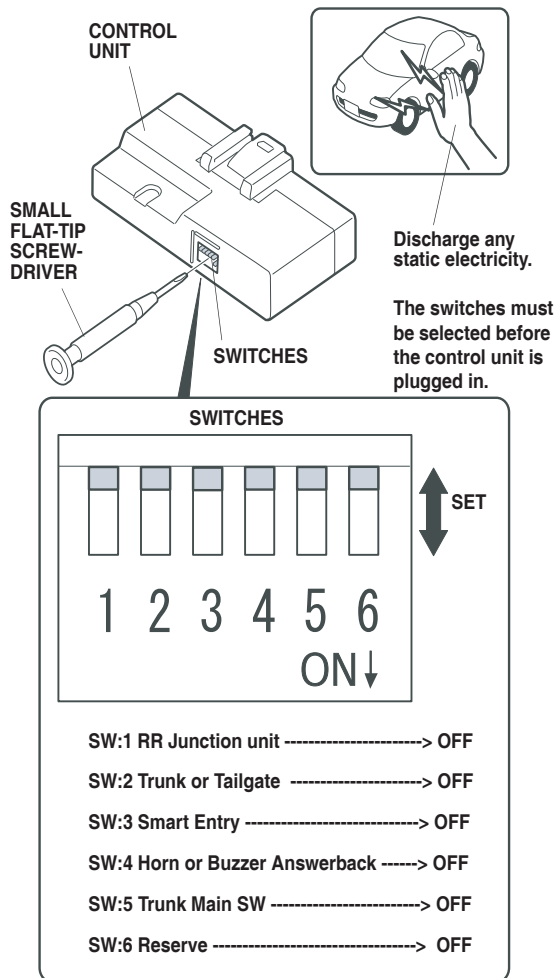

- SW : 1 RR Junction Unit
- SW : 2 Trunk or Tailgate
- SW : 3 Smart Entry
- SW : 4 Horn or Buzzer Answer Back
- SW : 5 Trunk Main SW
- SW : 6 Reserve

### Removing the vehicle parts

- Remove the trunk lid/fuel fill door opener cover (six retaining tabs). Remove one self-tapping screw.

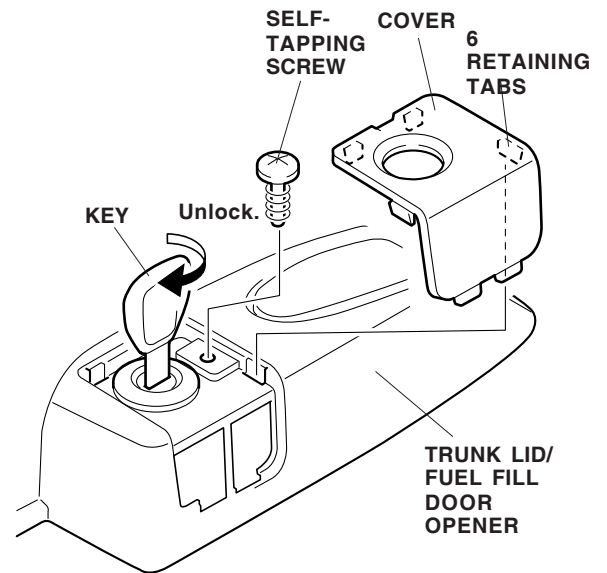

5. Using the key, unlock the opener.
6. Remove the left front door sill trim (two retaining tabs, five clips, and three hooks).

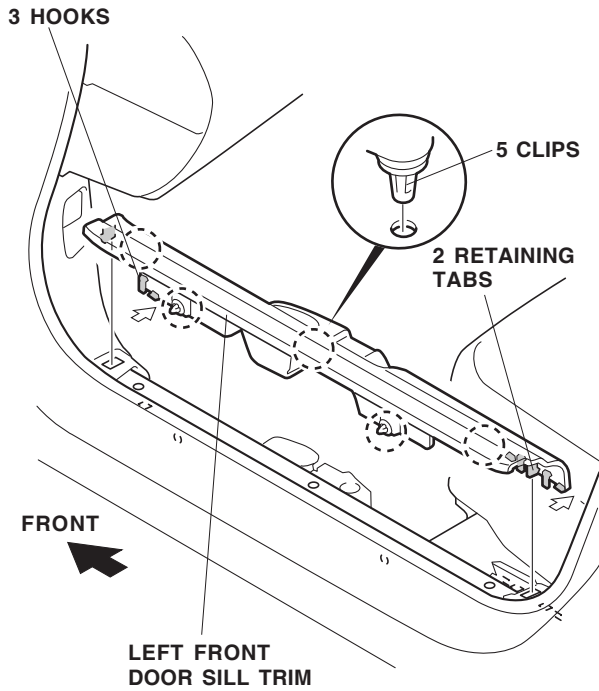

7. Pull away the weatherstrip, and remove the left kick panel (two clips).

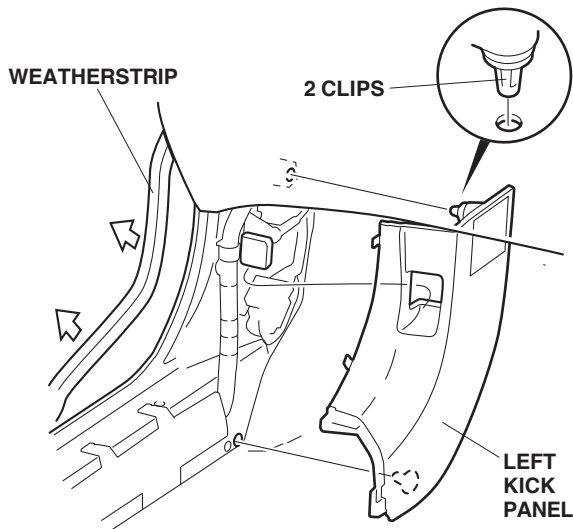

8. If equipped, remove the driver's dashboard under cover (turn the knob counterclockwise, and release two clips and pin).

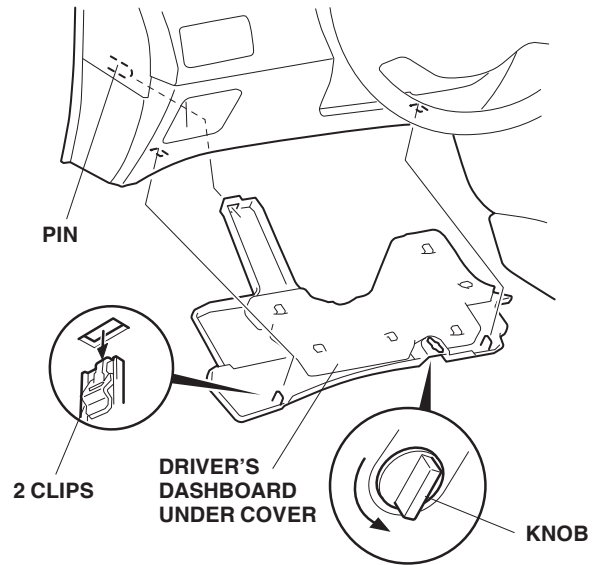

9. Remove the driver's dashboard lower cover (eight clips).

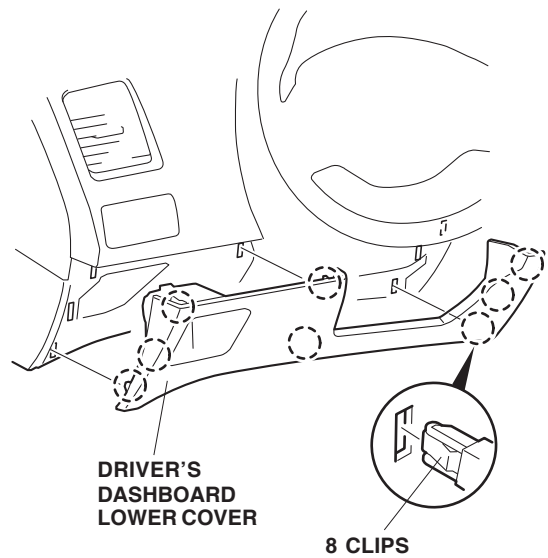

10. Lower the tilt lever, and pull the steering wheel toward you. Insert a long blade flat-tip screwdriver along the guide of the column lower cover, and pry the retaining tab of the column upper cover.

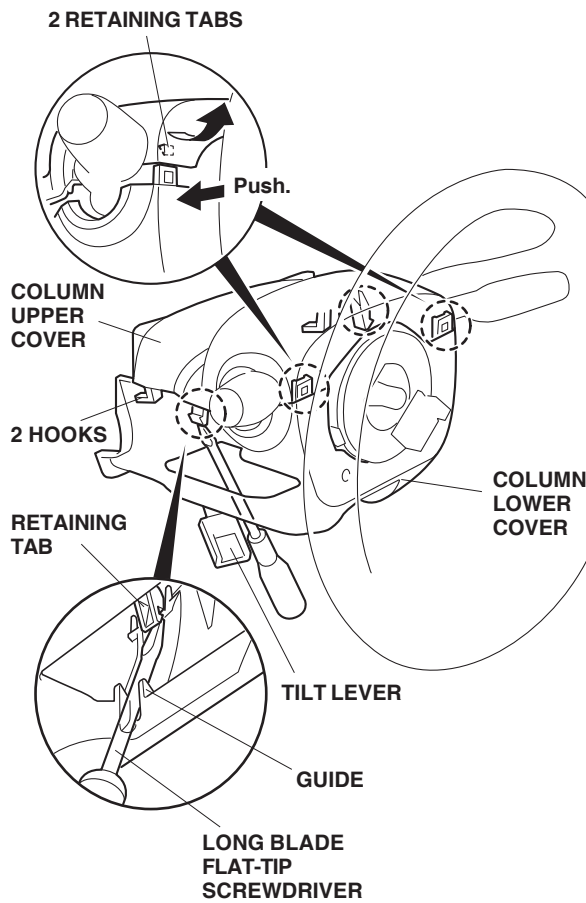

11. Push on the column lower cover in the area shown to separate the column upper cover from the column lower cover (two retaining tabs). Pull up to remove the column upper cover (two hooks).

12. Remove the column lower cover (two self-tapping screws and one screw).

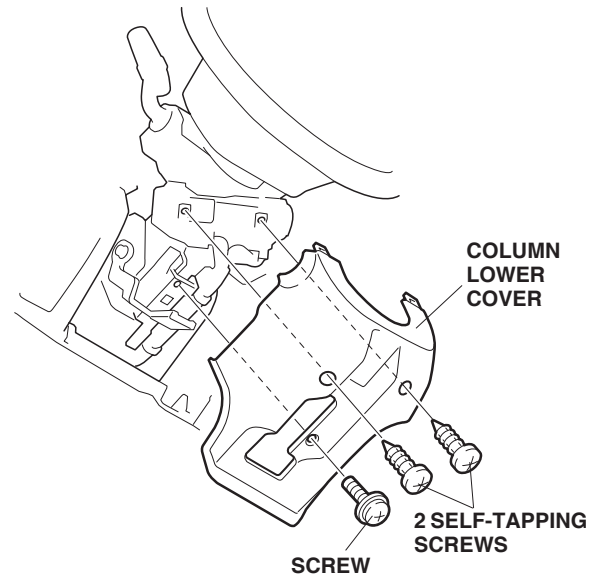

13. If equipped, use a small flat-tip screwdriver to remove the left and right lens from the map light console (four retaining tabs for each lens). Remove the two bolts, and then release the map light console.

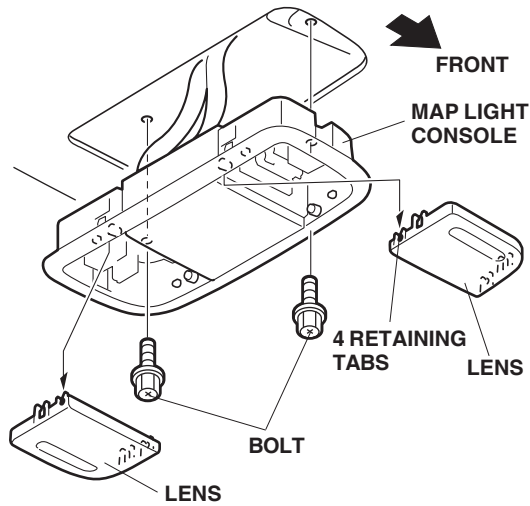

14. Remove the sunvisor holders. Using a small flat-tip screwdriver, push the hook, and turn the holder 90°, then pull it out.

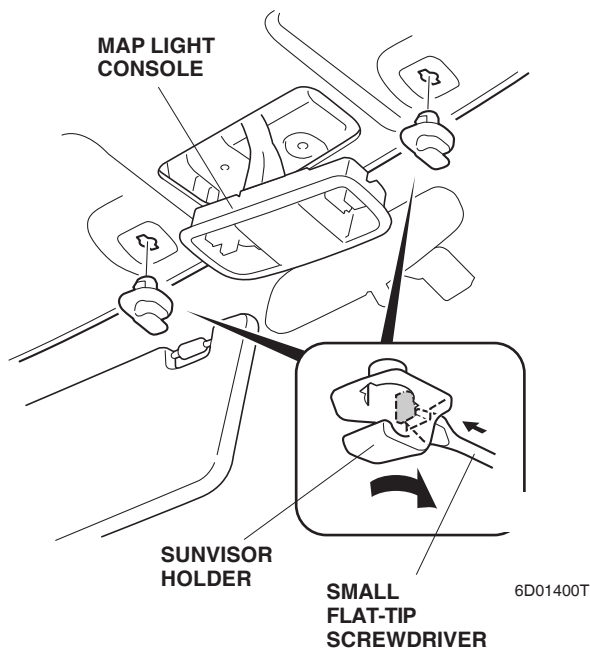

15. Remove the cap from the left sunvisor (four retaining tabs).

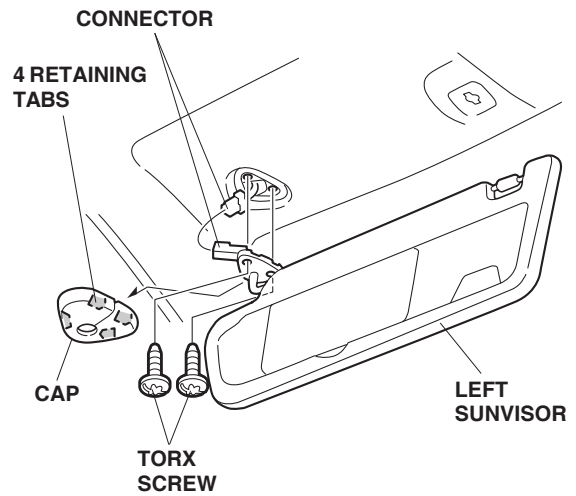

16. Remove the left sunvisor (two T25 Torx screws, and unplug the vehicle connectors).

17. Pull away the weatherstrip from the left front pillar trim.

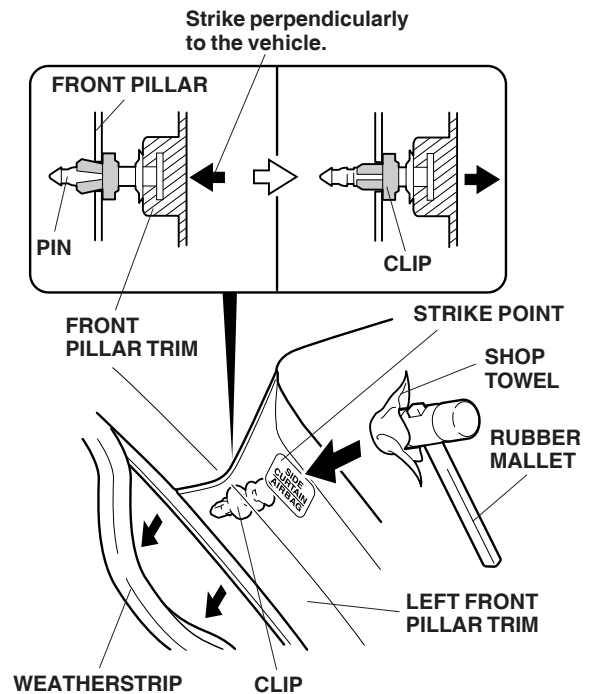

18. Using a rubber mallet and a shop towel, gently tap the left front pillar trim at the position shown to release the clip. Gently tap the pillar trim at the area marked as "SIDE CURTAIN AIRBAG".

19. Pull away the weatherstrip from the left front pillar trim. Remove the left front pillar trim (two clips).

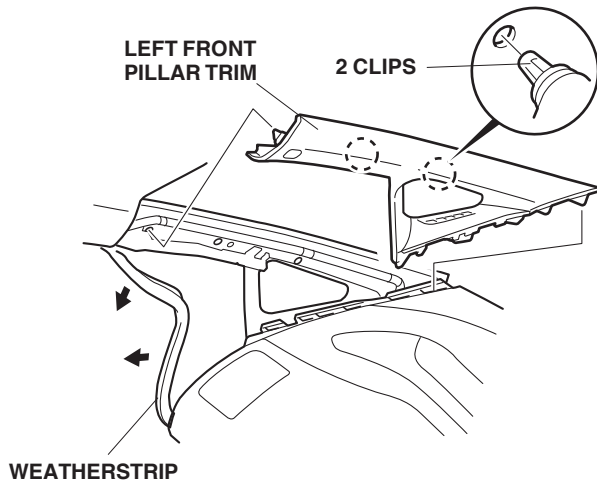

20. Remove the clip from the left front pillar trim, and install a new clip on the left front pillar trim.

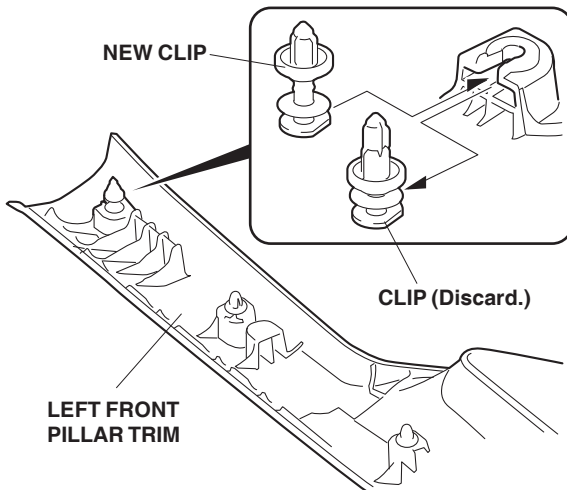

## Installing the Antenna

21. Using scissors, cut out the template.

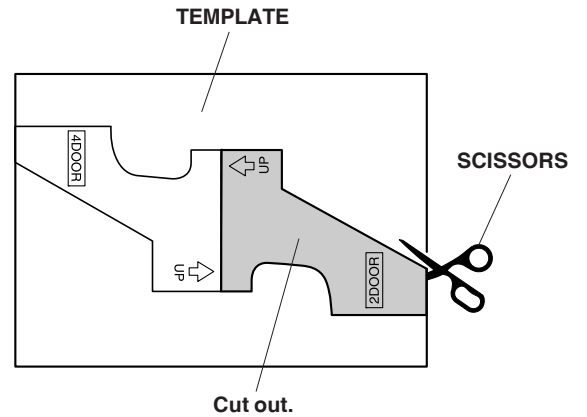

22. Secure the template to the windshield with the tape by aligning it with the edge of the black ceramic paint as shown.

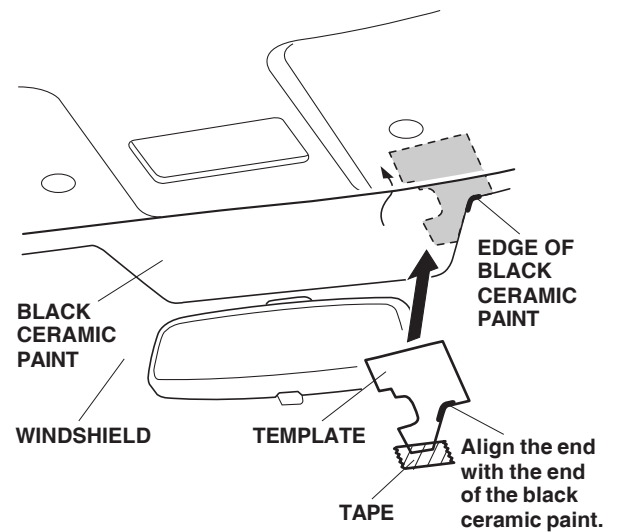

23. Using two pairs of needle-nose pliers, bend the antenna plate according to the illustration and measurement shown.

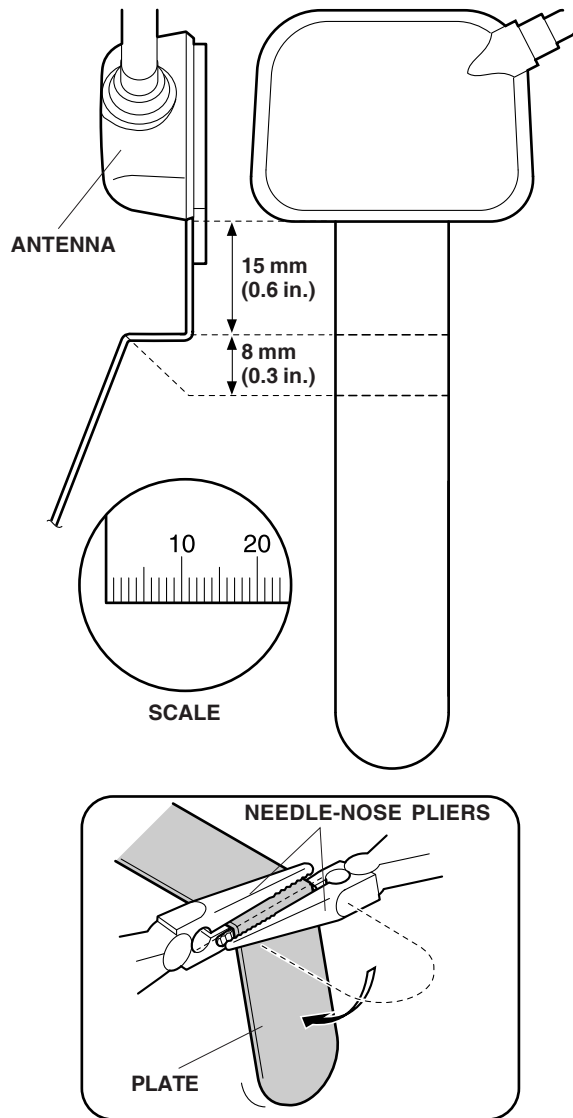

24. Measure the antenna cable as shown. Attach the three foam cushion tapes to the antenna cable in the measurement shown.

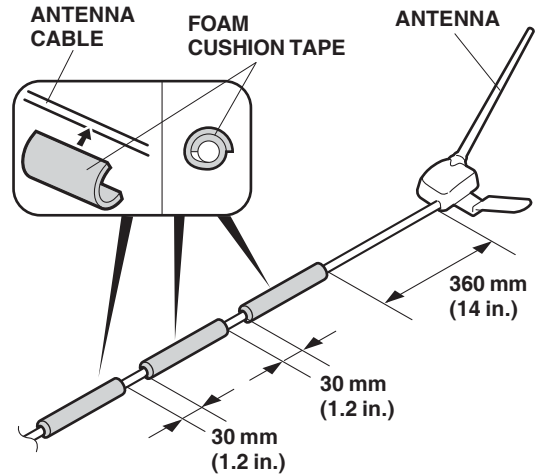

25. Using isopropyl alcohol on a shop towel, clean the area where the antenna will attach. Allow to dry before proceeding.

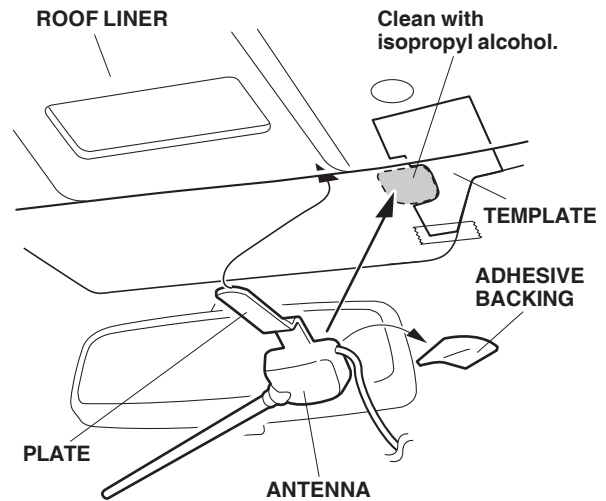

26. Remove the adhesive backing from the antenna, insert the antenna plate under the roof liner, and attach the antenna to the windshield aligning the template.
27. Remove the template.

28. Route the antenna cable under the roof liner towards the driver's side of vehicle, and down along the vehicle harness. Be careful not to crease the roof liner.

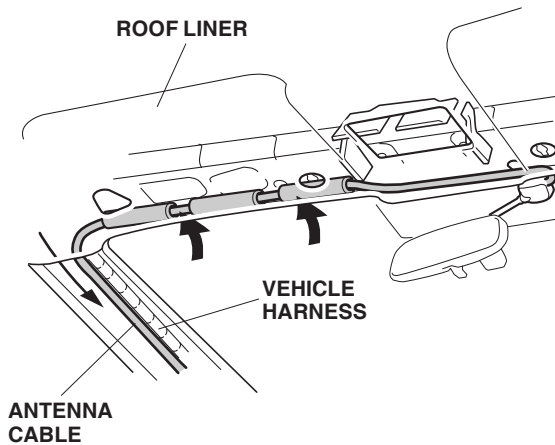

29. Continue routing the antenna cable between the front pillar and the dashboard.

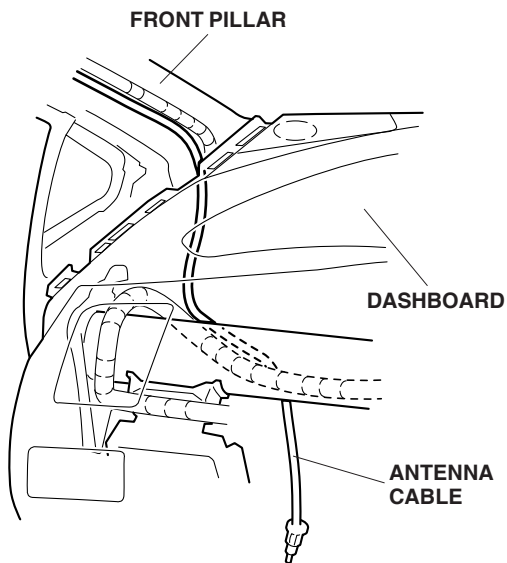

30. Using isopropyl alcohol on a shop towel, clean the areas where the foam cushion tape will attach. Under the roof liner, secure the antenna cable to the roof panel with the two foam cushion tapes (cut one foam cushion tape in half) in the areas shown.

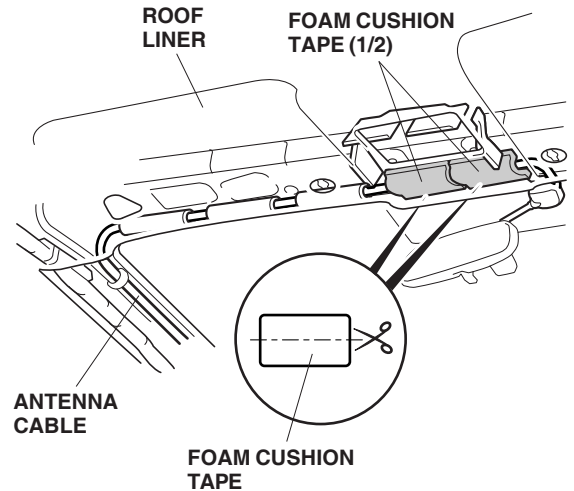

31. Secure the antenna cable to the vehicle harness with four wire ties as shown. Do not secure the antenna cable to the drain tube.

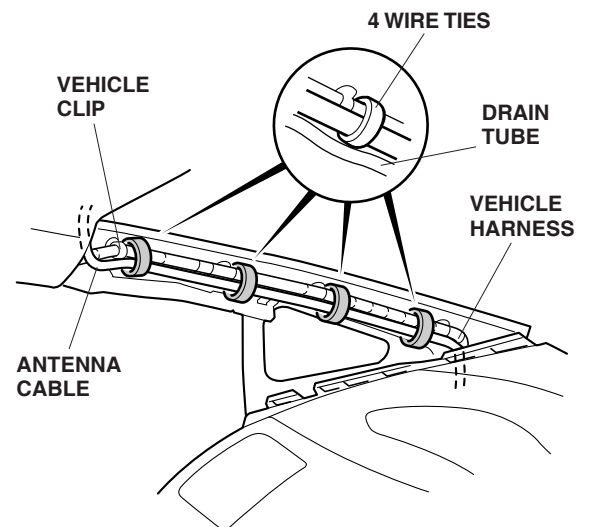

32. Secure the antenna cable to the vehicle harness with a wire tie. Secure the wire tie between the vehicle harness branching points.

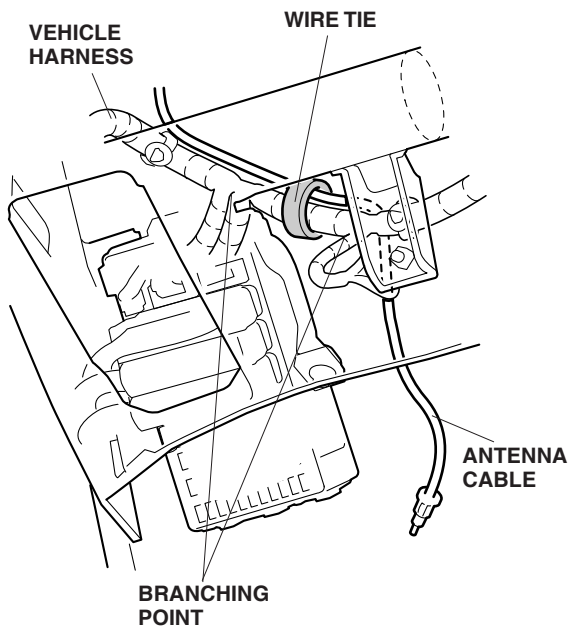

### Installing the Control Unit Bracket

33. Locate the small square hole next to the small round hole in the dashboard support bracket. Under the dashboard, attach the control unit bracket to the vehicle bracket near the front lower pillar using a flange nut. If the vehicle is equipped with a moonroof, be careful not to pull on the drain tube.

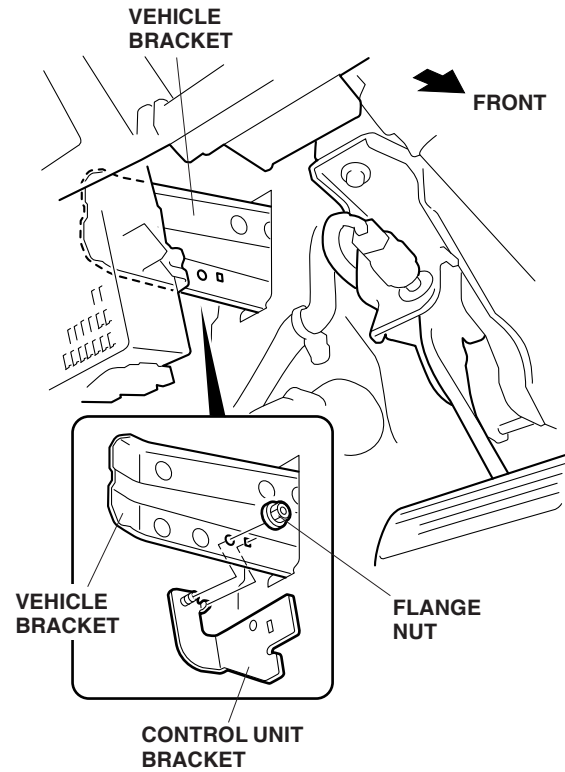

## Routing the Engine Starter Harness

34. Attach the 3A fuse labels to the engine starter harness fuse case, and the 40A fuse labels to the fuse block.

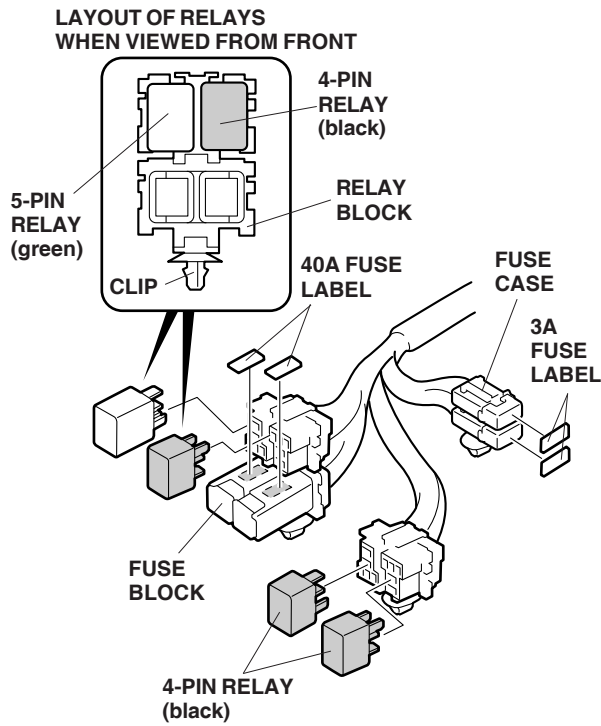

35. Install the four relays to the engine starter harness relay blocks. Be careful to install the relays properly, or a malfunction will result.

36. Route the engine starter harness 7-pin connectors up the steering column and to the ignition switch. Unplug the white vehicle 7-pin connector. Plug the white engine starter harness 7-pin connectors into the white vehicle 7-pin connectors.

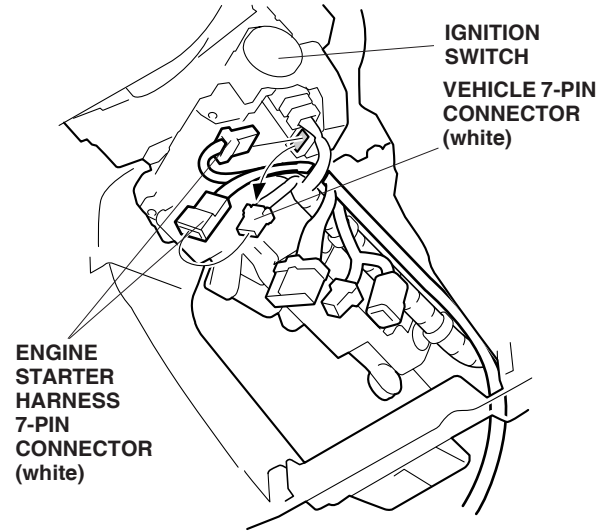

37. Unplug the brown vehicle 7-pin connector, and plug the brown engine starter harness 7-pin connector into the brown vehicle 7-pin connector.

**NOTICE** Make sure that the engine starter harness 7-pin connector (brown) is connected to the vehicle connector and it is locked securely. A loosely connected connector can cause engine stall during driving.

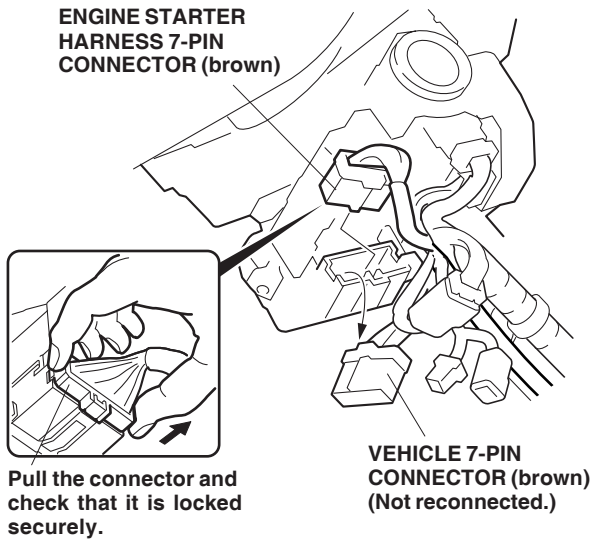

38. Disconnect the vehicle 8-pin connector on the rear of the wiper switch and plug the engine starter harness 8-pin connectors into the vehicle 8-pin connector.

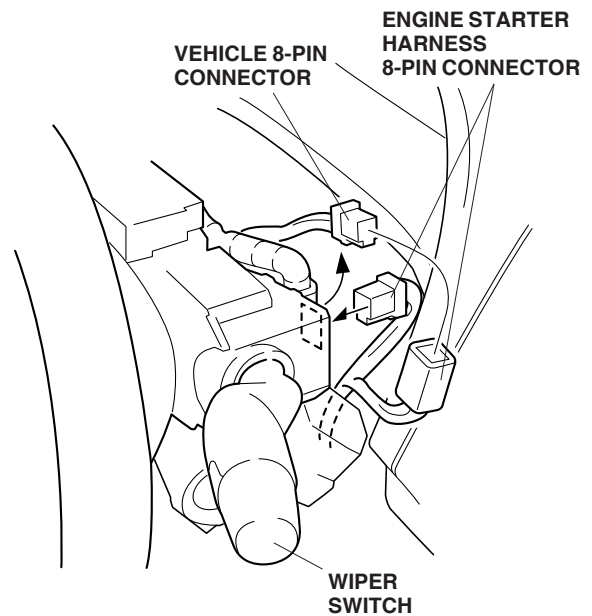

39. Secure the connected 8-pin connector with a wire tie to the engine starter harness.

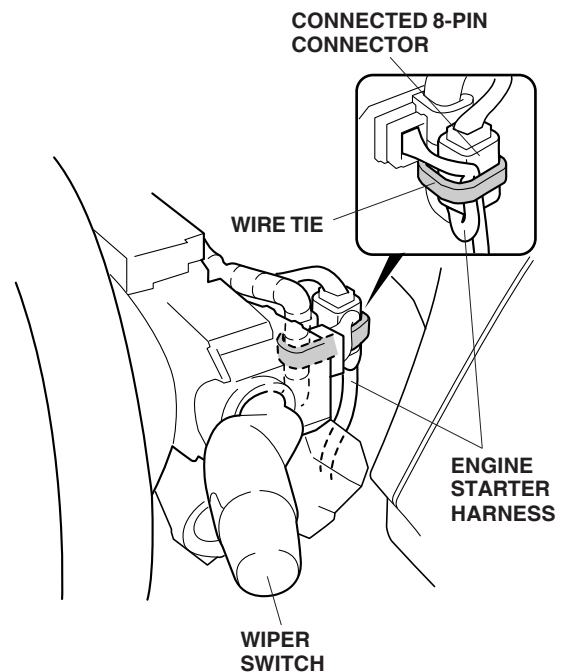

40. Wrap the vehicle 7-pin connector with one foam cushion tape, then place the vehicle 7-pin connector into the gap of the column.

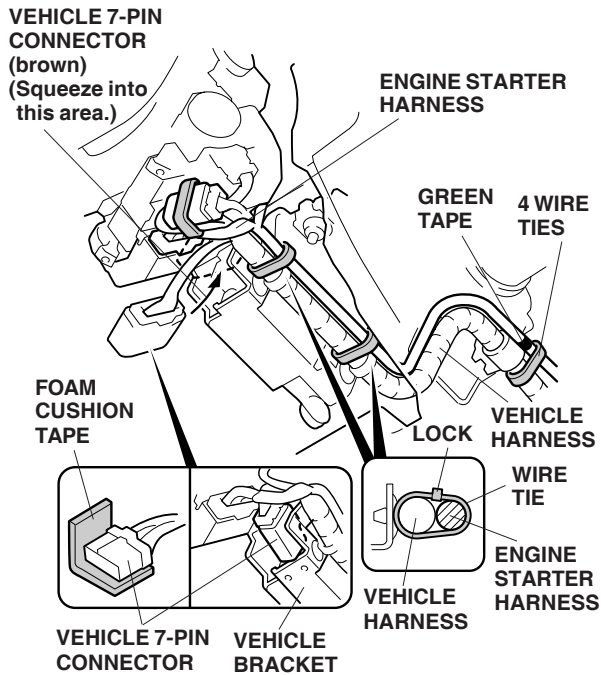

41. Secure the engine starter harness to the vehicle harness with four wire ties in the areas shown. The lock of the wire ties should face up.
42. Remove the lower steering column support bracket bolt. Attach the relay bracket to the steering column support bracket and reinstall the steering column support bracket bolt.

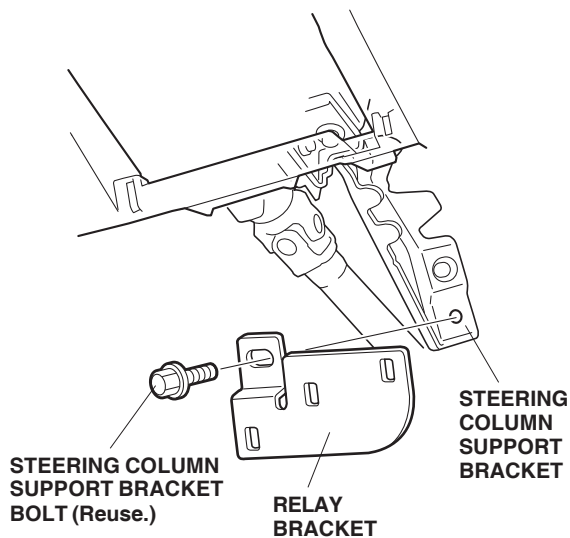

43. At the right of the steering shaft, locate the sub joint box. Using a small flat-tip screwdriver, unplug the vehicle 6-pin connector from the sub joint box. Plug the engine starter harness 6-pin connectors into the vehicle 6-pin connector and the subjoint box.

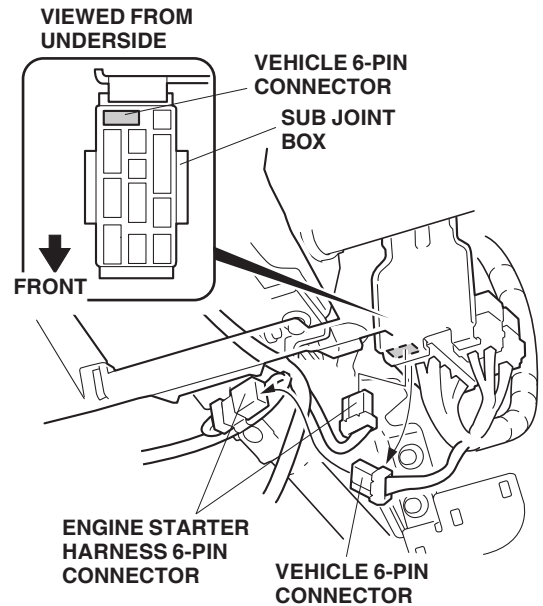

44. Attach the relay blocks and fuse case on the relay bracket.

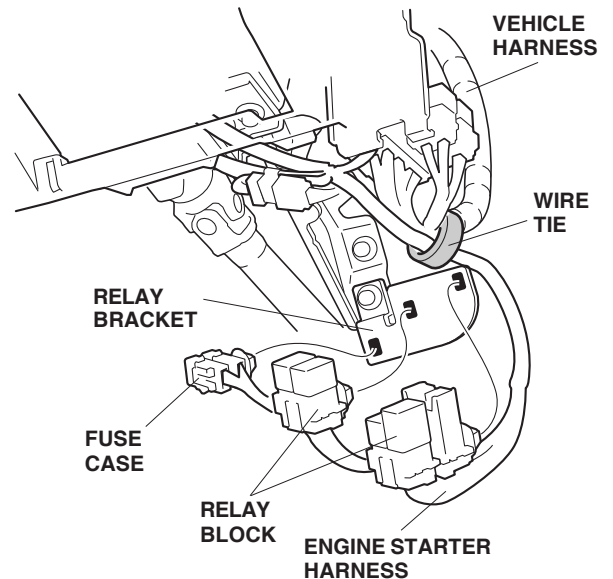

45. Secure the engine starter harness to the vehicle harness using a wire tie.

46. **With driver's dashboard under cover:** Measure the indicated dimension on the instrument panel and mark with a felt-tip pen and a center punch.

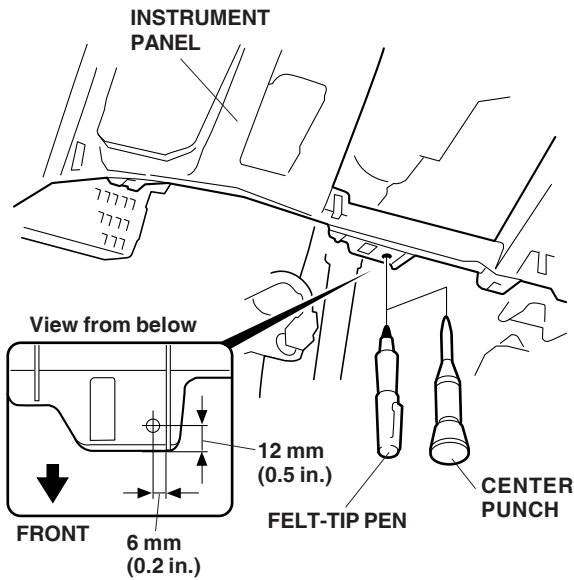

- Drill a 3 mm hole and then a 7 mm hole at the marked position of the instrument panel.
  - Wear safety goggles during drilling.
  - Using a file, remove the burrs at the edges of the holes you made.

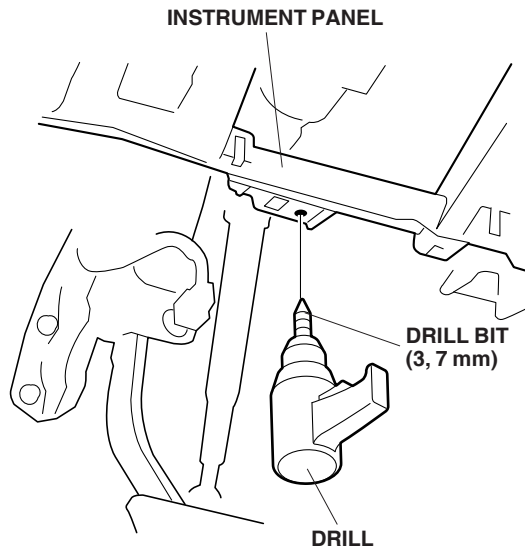

47. Secure the engine starter harness to the vehicle harness using a wire tie:

- **With driver's dashboard under cover:** Secure in the hole opened in the instrument panel.
- **Without driver's dashboard under cover:** Secure through the existing hole for under cover securing.

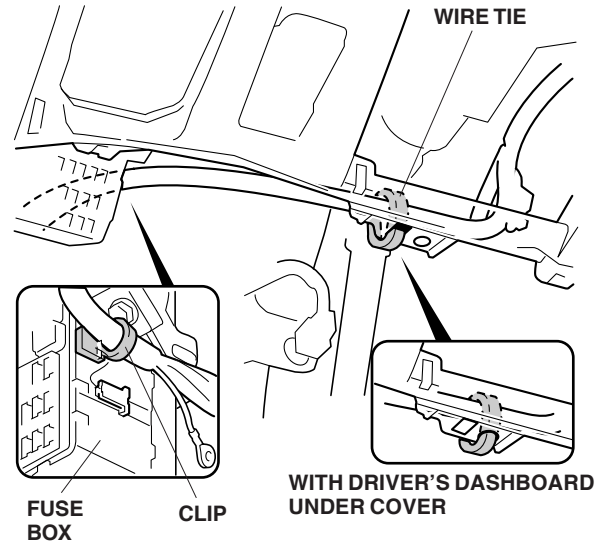

48. Use the clip on the engine starter harness to secure the engine starter harness to the fuse box.

49. Disconnect the vehicle 42-pin, 4-pin, and 2-pin connectors.

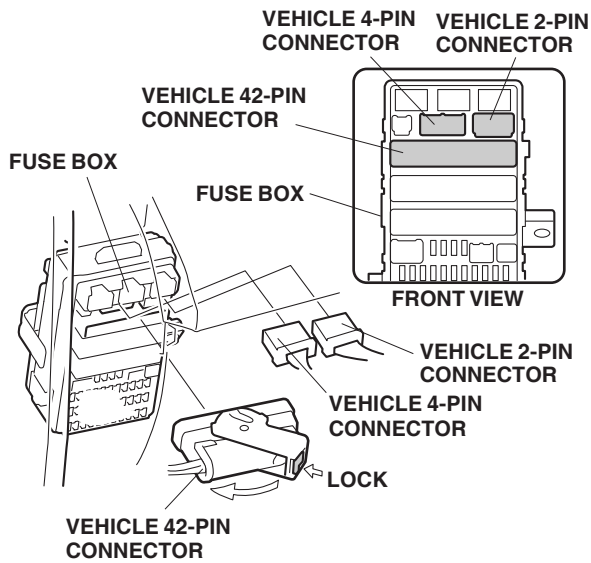

50. Plug the engine starter harness 4-pin and 2-pin connectors into the fuse box.

**NOTICE** Check that the engine starter harness 4-pin and 2-pin connectors are connected to the fuse box and they are locked securely. Loosely connected connectors can cause engine stall during driving.

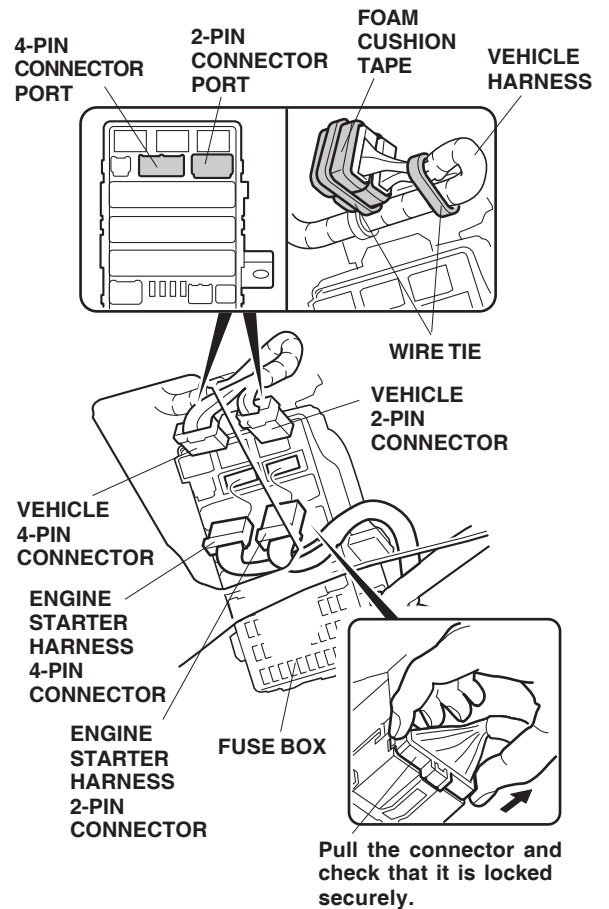

51. Wrap foam cushion tape to the vehicle 2-pin and 4-pin connectors and secure them with a wire tie. Then, secure the vehicle harness with a wire tie. Reconnect the vehicle 42-pin connector.

52. Behind the fuse box, unplug the blue vehicle 23-pin connector from the inside of the front lower pillar, and plug the blue engine starter harness 23-pin connectors into the blue vehicle 23-pin connector. If the vehicle 23-pin connector is difficult to disconnect, perform the work after first disconnecting the connector on the upper side.

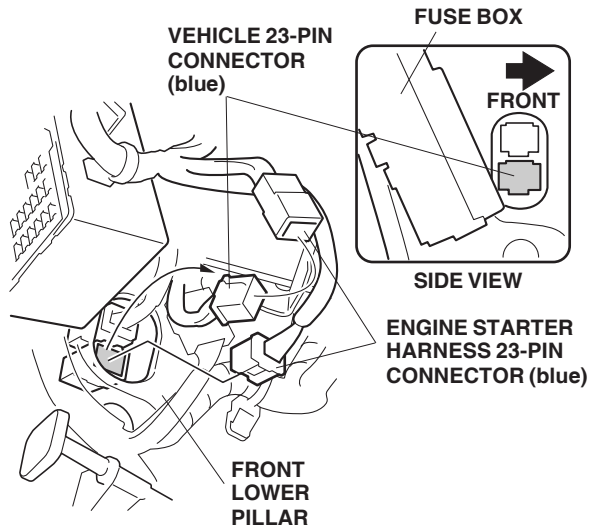

53. Unplug the white vehicle 14-pin connector at the front lower pillar behind the fuse box, and plug the engine starter harness 14-pin connectors into the white 14-pin connector. Attach the engine starter harness 14-pin connector to the vehicle 14-pin connector.

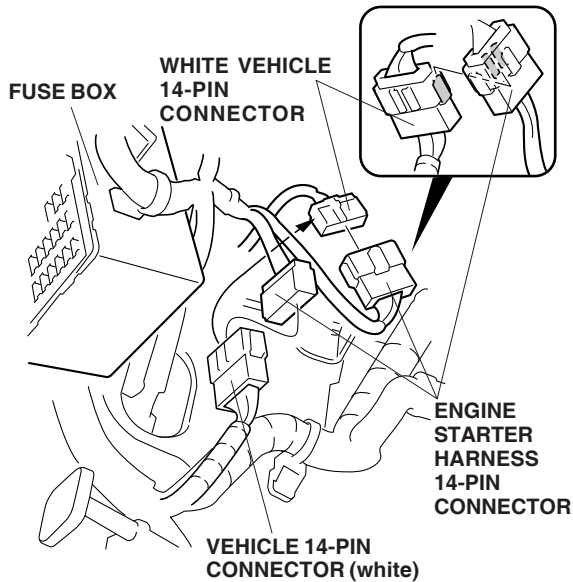

54. Install the clip from the engine starter harness to the fuse box bracket behind the fuse box.

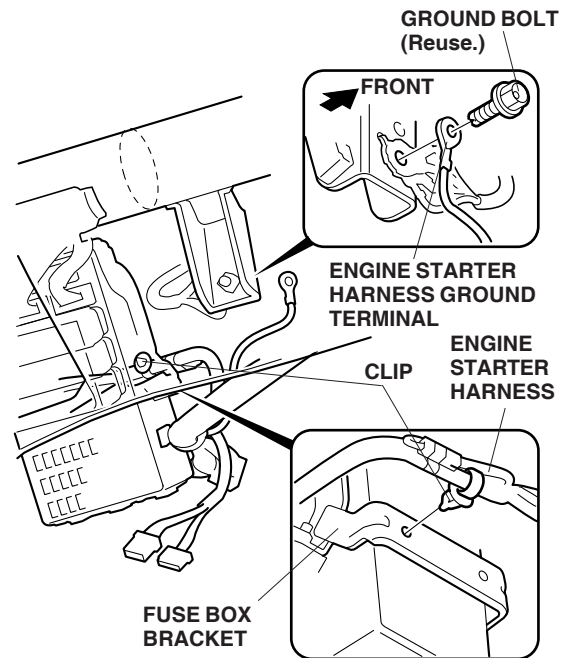

55. Remove the ground bolt from the vehicle. Secure the engine starter harness ground terminal with the ground bolt you just removed.

## Installing the Control Unit

56. Connect the antenna cable terminal and the engine starter harness 18-pin connector to the control unit.

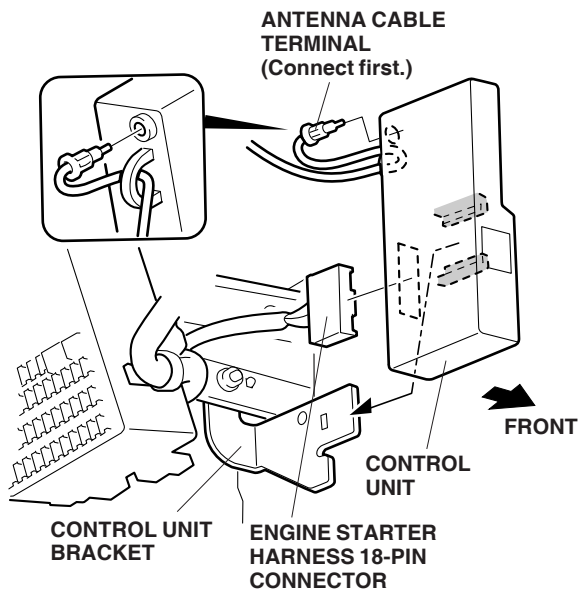

57. Install the control unit on the control unit bracket.
58. Bundle the excess antenna cable with two wire ties and secure it with one wire tie to the vehicle harness.

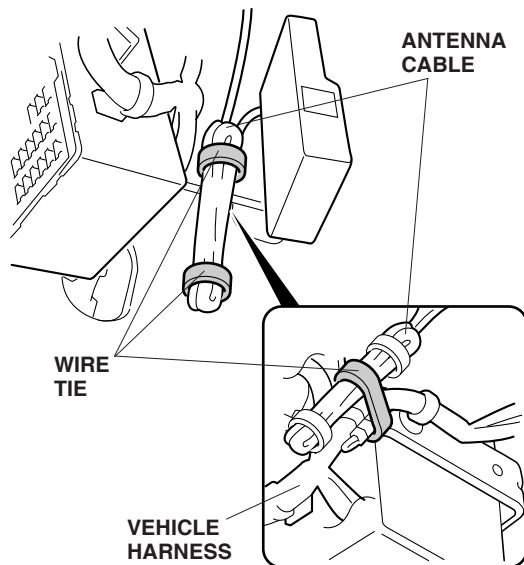

59. Using isopropyl alcohol on a shop towel, clean the area where the engine starter label will attach.

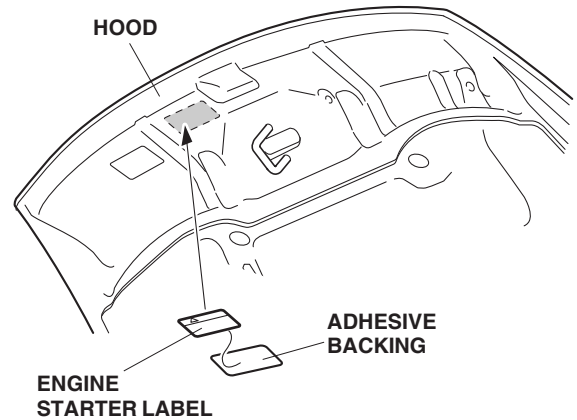

60. Attach the engine starter label to the back of the hood.
61. Check that all wire harnesses are routed properly and all connectors are plugged in.
62. Reinstall all removed parts. Check that all clips and other fasteners are installed securely. Take care not to pinch the airbag with a clip during reinstallation of the front pillar trim. Do not push the front pillar trim excessively.
63. Reconnect the negative cable to the battery. Check that the electrical accessory and other electrical systems function properly.
64. Perform **REMOTE ENGINE STARTER REGISTRATION**, on pages 18-20, and **FUNCTION CHECK**, on page 21.
65. Enter the customer's radio anti-theft code, and reset the radio station presets.
66. Reset the clock.

## REMOTE ENGINE STARTER REGISTRATION

1. Acquire the PCM code from ISIS.
2. Connect the HDS tester to the OBD II data link connector, then turn the ignition switch to the ON (II) position.
3. Start the HDS, and click the car icon.

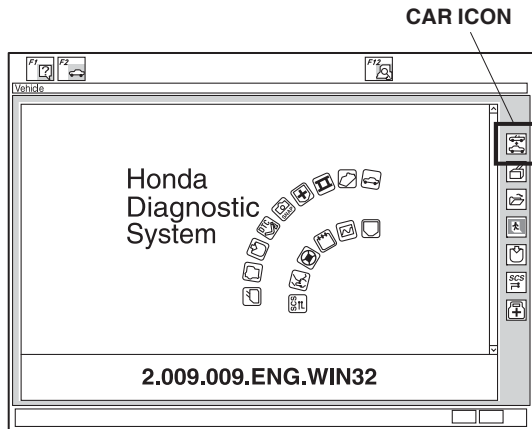

4. Input the VIN and other required information into the HDS, then click the check button.

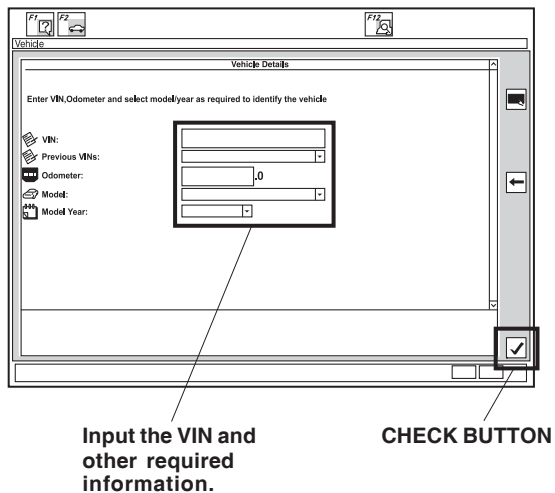

5. Select **Honda Systems**, then click the check button.

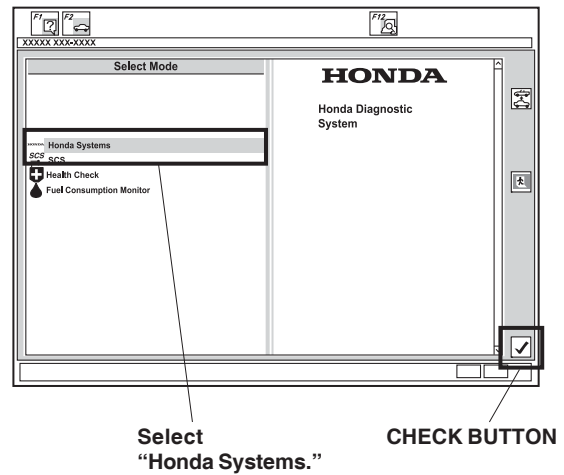

6. Select **R/C ENG STARTER** and click the check button.

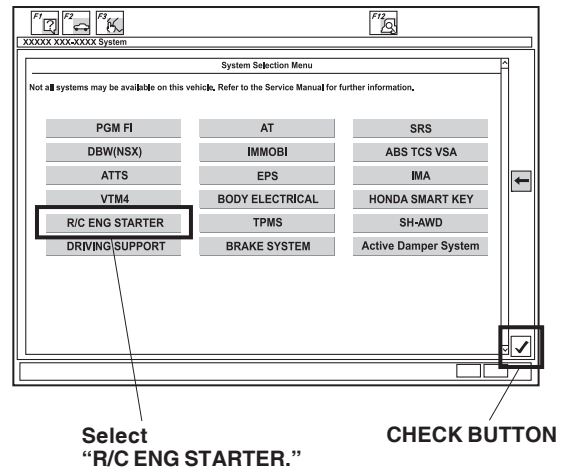

7. A **REMARKS** message will display. Click the check button.

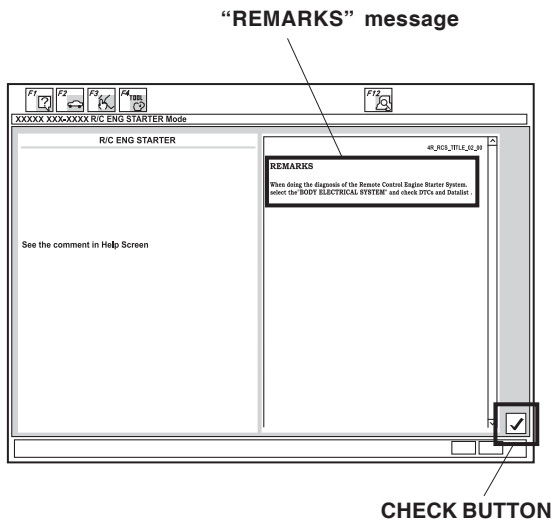

8. Select **REGISTER REMOTE CONTROL ENGINE STARTER UNIT**, then click the check button.

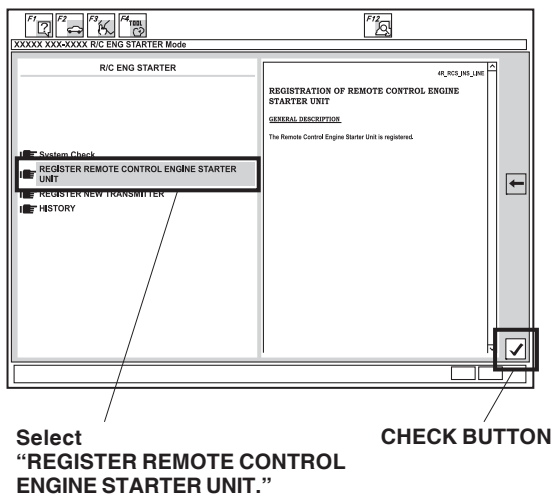

Select  
"REGISTER REMOTE CONTROL  
ENGINE STARTER UNIT."

9. The following message will display: **Obtain PCM-code (IMMOBILIZER PCM CODE) from iN.** This vehicle's VIN will be required to obtain the password. (USA). Click the check button.

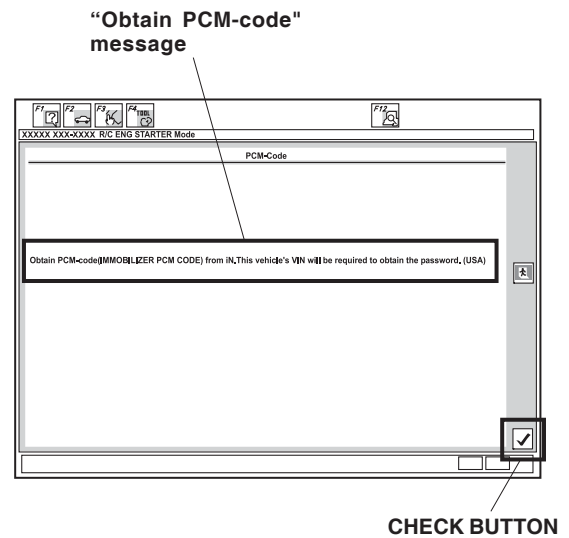

10. Input the PCM code, then click the check button.

NOTE: To ensure security, the PCM code (password) is changed every day, so it is impossible to register the remote control engine starter if the dates of the PCM code acquisition and registration are different. The date of the HDS tester should also be the same.

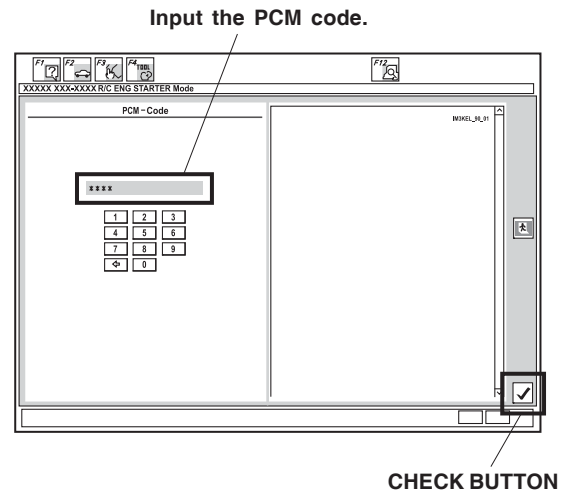

11. The following message will display: **The registration of the Remote Control Engine Starter Unit has been completed.** Click the check button.

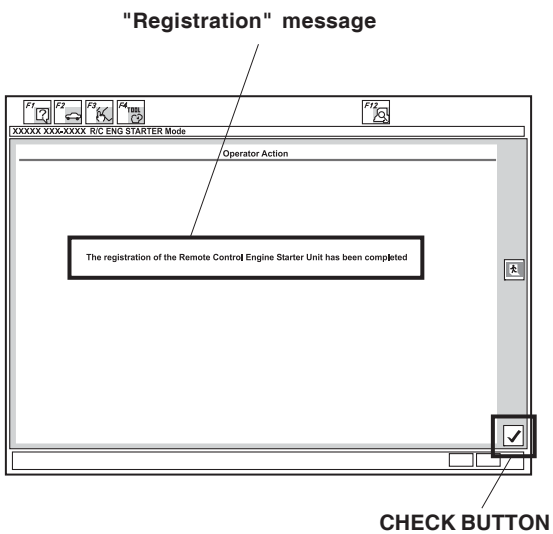

12. The following message will display: **Check that the engine can be started by the Transmitter.** Click the check button.

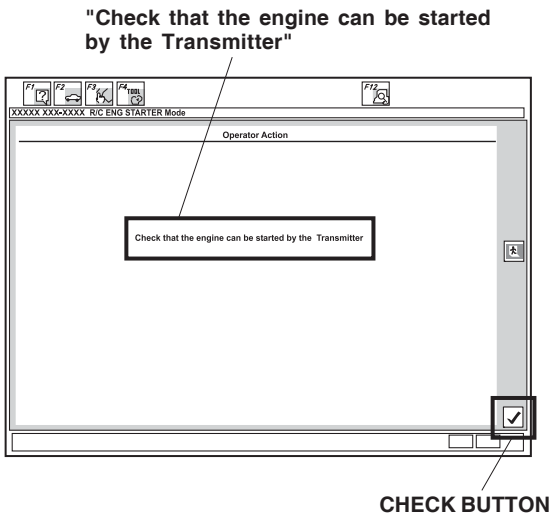

13. Perform the function check on page 21, then disconnect the HDS.

## FUNCTION CHECK

### Operating Conditions

- The hood is closed.
- The shift lever is in Park.
- The key is not in the ignition switch.
- All doors and trunk are closed and locked.

### Inspection

1. Within 1 second, press the command button and then the start button on the transmitter. The engine should start if all operating conditions are met.

Does the engine start?

Yes - Operation is normal.

No:

- Make sure all operating conditions are met.
- Check the engine starter harness connections.
- Connect the HDS and check for an indicated failure.  
(Refer to the appropriate service manual for details.)

2. Press the command button on the transmitter, and within 1 second, press the stop button. The engine should stop.

Does the engine stop?

Yes - Operation is normal.

No - Check the engine starter harness connections.

3. After the engine has stopped, start the engine again, and check that the engine stops after each of the following conditions:

NOTE: After each test the ignition key must be cycled, or the driver's door must be opened and closed.

- Move the shift lever out of the P position.
- Unlock or open the doors or the trunk lid.
- Open the hood.
- Insert the key in the ignition switch.
- Press on the brake pedal.

Does the engine stop after each of these tests?

Yes - Operation is normal.

No - Check the engine starter harness connections.

4. Check that the power windows or the moonroof does not function when the engine is started with the transmitter.
5. Press the command button on the transmitter twice and check the vehicle condition on the display.
6. Check the operation of the transmitter when the vehicle is 100 m to 150 m (325 to 490 ft.) away and when the vehicle is in direct sight.

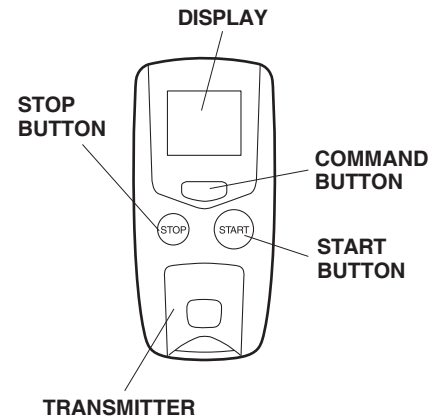

## How to Program an Additional Transmitter

1. Connect the HDS to the data link connector.
2. Start the HDS and click on the car icon.
3. Input the vehicle's VIN and other required information.
4. Select **Honda Systems**.
5. Select **R/C Engine Starter**.
6. Select **REGISTER NEW TRANSMITTER**.
7. When "Ready to program the new transmitter" shows, select **ENTER**.
8. Press and release the Command button.
9. Press and release the Stop button.
10. Perform the function check on both transmitters.

NOTE: Only 2 remotes can be stored in the system's memory.