



INSTALLATION INSTRUCTIONS

Accessory	Application	Publications No.
RUNNING BOARDS P/N 08L33-S9A-100	CR-V	All 23085
		Issue Date
		NOV 2001

PARTS LIST

2 Running boards

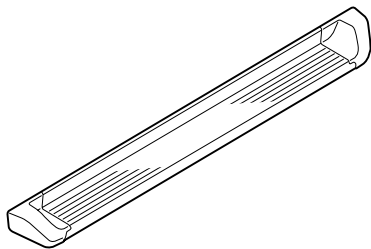

6 Brackets A

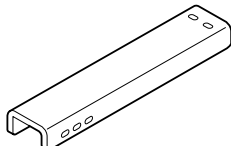

6 Brackets B

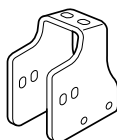

6 Brackets C

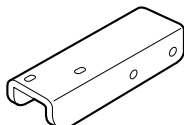

72 Flange bolts



60 Flange nuts



TOOLS REQUIRED

Ratchet

13 mm Combination wrench

13 mm Socket

Torque wrench

INSTALLATION

Customer Information: The information in this Installation Instruction is intended for use only by skilled technicians who have the proper tools, equipment, and training to correctly and safely add equipment to your vehicle. These procedures should not be attempted by "do-it-yourselfers."

1. Position the three brackets B on the underside of the body, and install the two flange bolts for each bracket B. Torque all the flange bolts to 27 N·m (20 lb-ft).

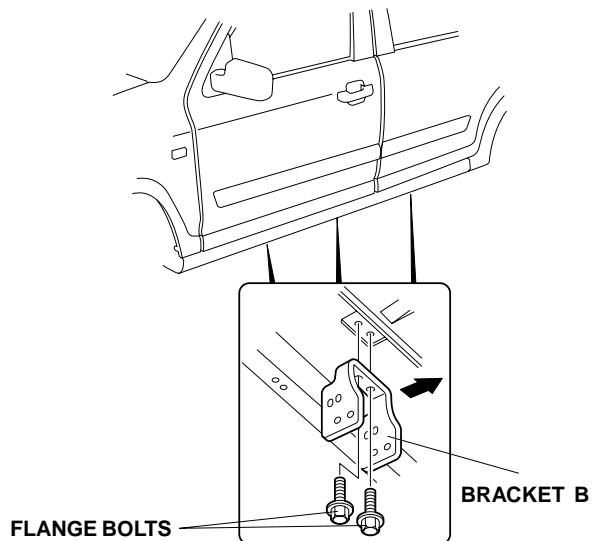

2. Position the three brackets A in the brackets B you just installed, and install the six flange bolts and four flange nuts for each bracket A. Torque all the flange bolts to 27 N·m (20 lb-ft).

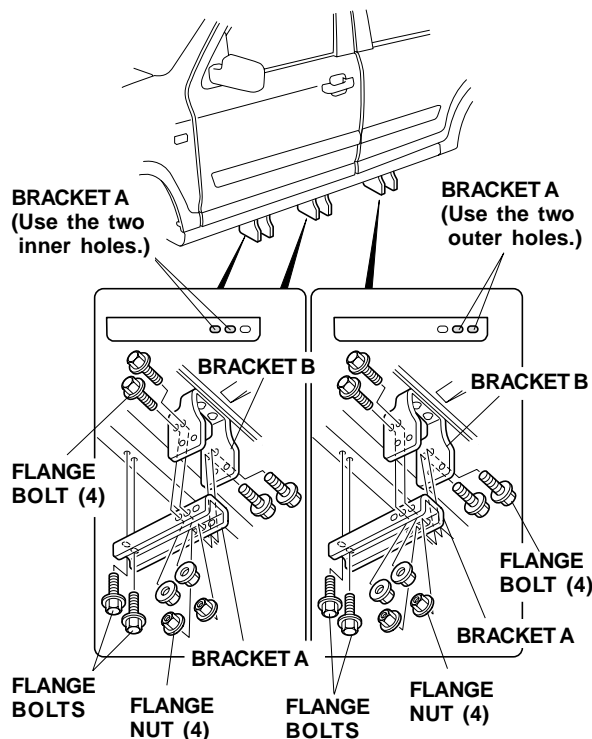

- Position the three brackets C in the brackets B, and install the two flange bolts and two flange nuts. Do not tighten them yet.

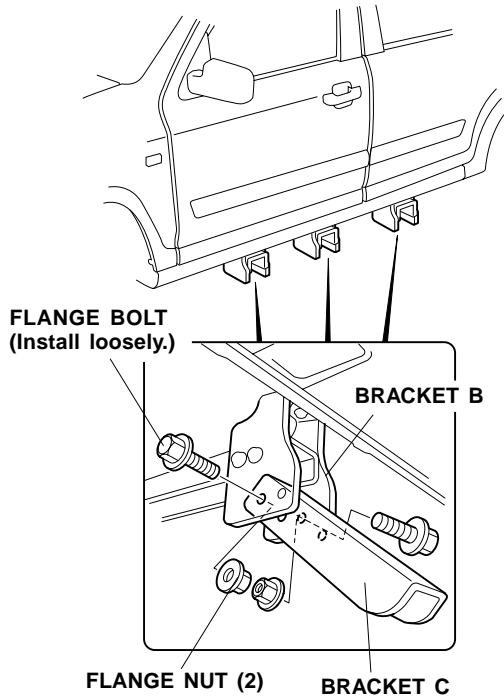

- Insert the six studs of the running board into the holes in the three brackets C, then install a flange nut on the end of each stud, but do not tighten the flange nuts yet.

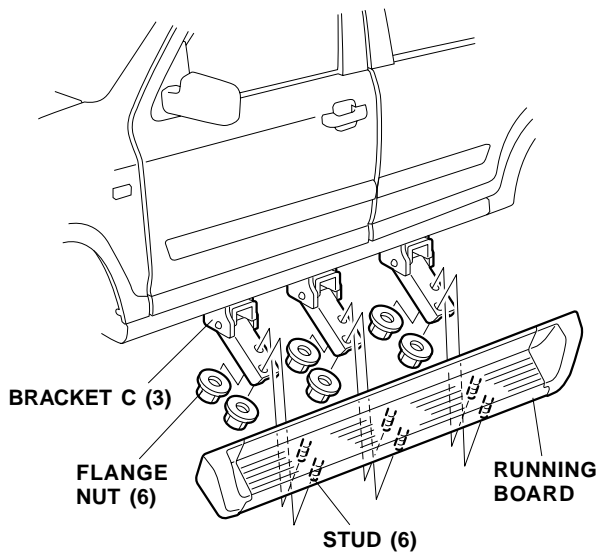

- Raise the running board to align the holes in the brackets B with the holes in the brackets C. Install and tighten the two flange bolts and two flange nuts.

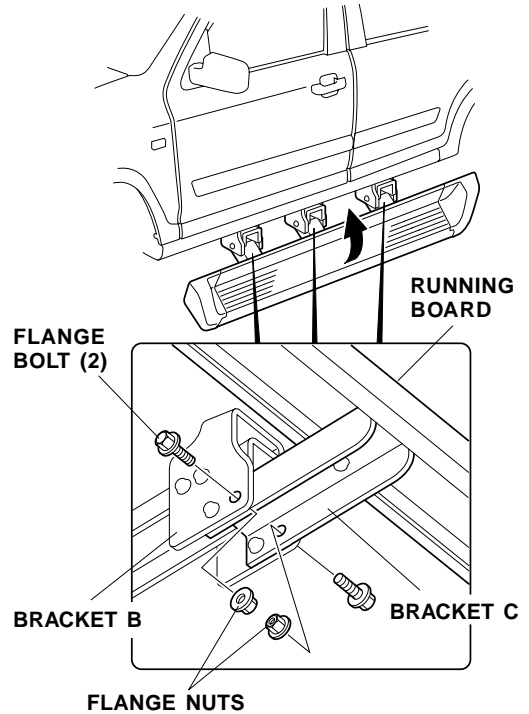

- Adjust the front of the running board, so it's equal with the body line, then tighten the six flange nuts installed in step 4.

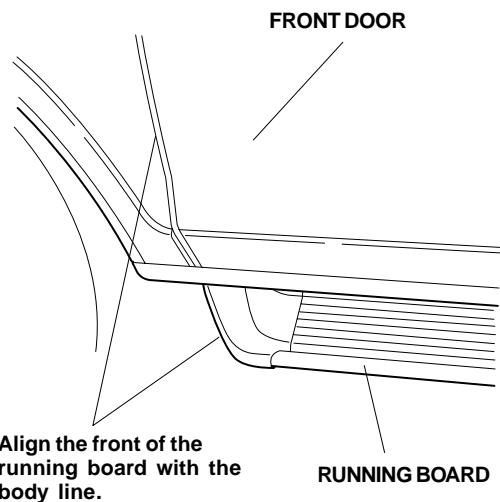

- Tighten all flange bolts installed in step 3.
- Torque all the flange nuts and bolts to 27 N·m (20 lb-ft).
- Repeat steps 1 through 8 to install the running board on the right side.

Make a copy of this page, and give it to your customer.

Important Jacking Information: The rear jacking point *cannot* be used when the vehicle is equipped with Honda accessory running boards, jack up the rear of the vehicle using the center running board bracket in the area shown. For information on changing a flat tire, refer to the vehicle Owner's Manual.

