



# INSTALLATION INSTRUCTIONS

Accessory	Application	Publications No.
<b>BODY SIDE CLADDING P/N 08P21-S9A-100</b>	<b>CR-V</b>	<b>All 23062</b>
		Issue Date <b>NOV 2001</b>

## PARTS LIST

Right front fender piece

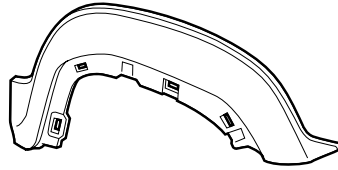

Left front fender piece

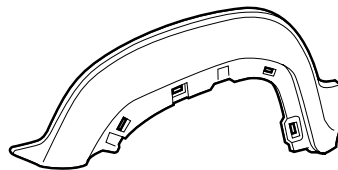

Right front door piece

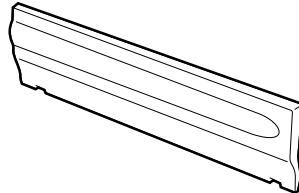

Left front door piece

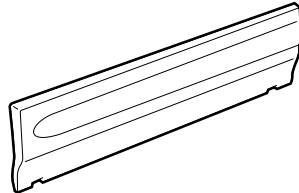

Right rear fender piece

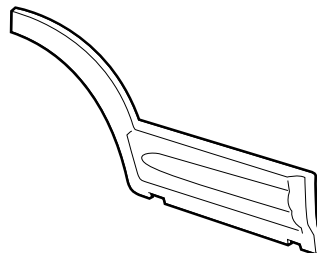

Left rear fender piece

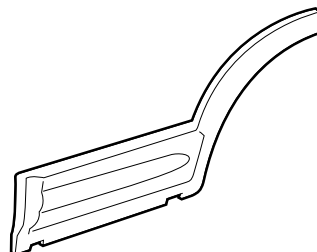

Right rear bumper piece

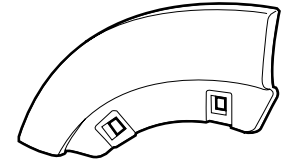

Left rear bumper piece

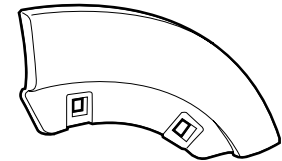

22 Clips



## TOOLS AND SUPPLIES REQUIRED

- Phillips screwdriver
- Flat-tip screwdriver
- Torx bit (T30)
- Tape measure
- Isopropyl alcohol
- Shop towel
- Masking tape
- Long nose pliers
- Adhesive tape
- Small flat-tip screwdriver
- String

## INSTALLATION

**Customer Information:** The information in this installation instruction is intended for use only by skilled technicians who have the proper tools, equipment, and training to correctly and safely add equipment to your vehicle. These procedures should not be attempted by "do-it-yourselfers."

### Installing the Front Fender Piece

1. Make sure you have the anti-theft code for the radio, then write down the frequencies for the preset buttons.
2. Disconnect the negative cable from the battery.
3. Remove the one bolt and three clips that fasten the left front inner fender, and pull the inner fender out in the direction shown. Take care not to damage the clips.

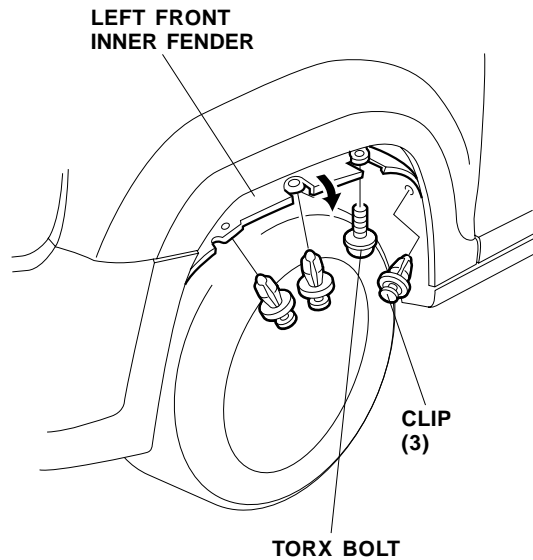

4. Remove the two self-tapping screws that fasten the left front wheelwell protector. Remove the front clip by squeezing the clip, and pulling the protector out toward you. Pull out on the wheelwell protector to release the remaining four clips, and remove the wheelwell protector. Take care not to damage the clips.

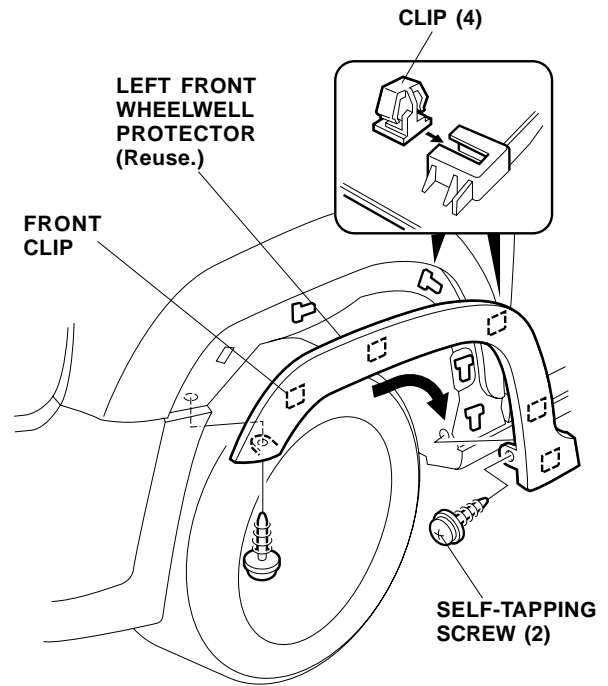

5. If any of the clips remained on the body, remove the clips from the body, and reinstall them on the left front wheelwell protector.

- Position the left front fender piece on the left front fender, and adjust it so that there is about 2 mm clearance between the front fender and fender piece at the rear end. Bring the step in the left front fender piece into contact with the step in the front fender.

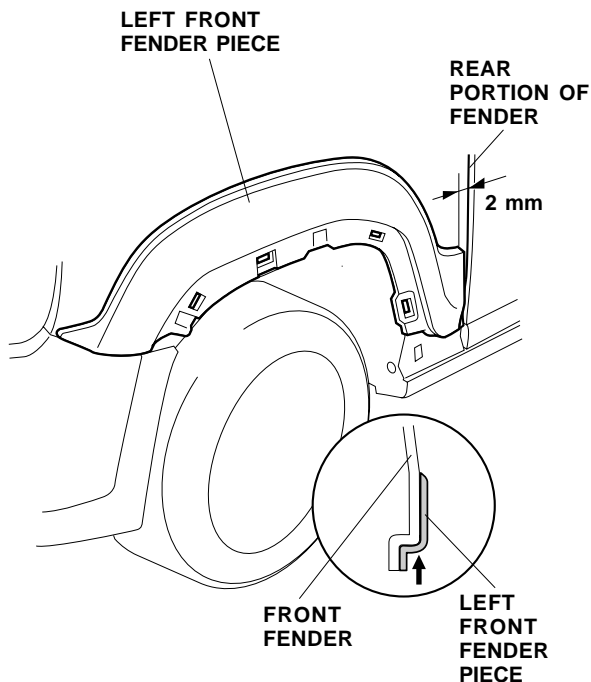

- Remove the left front fender piece, and peel off all lower adhesive backings as shown. Attach a strip of masking tape to both ends of the upper adhesive backing, and remove 5 to 6 inches from the ends. Fold the ends up and back, and tape them to the front of the fender piece.

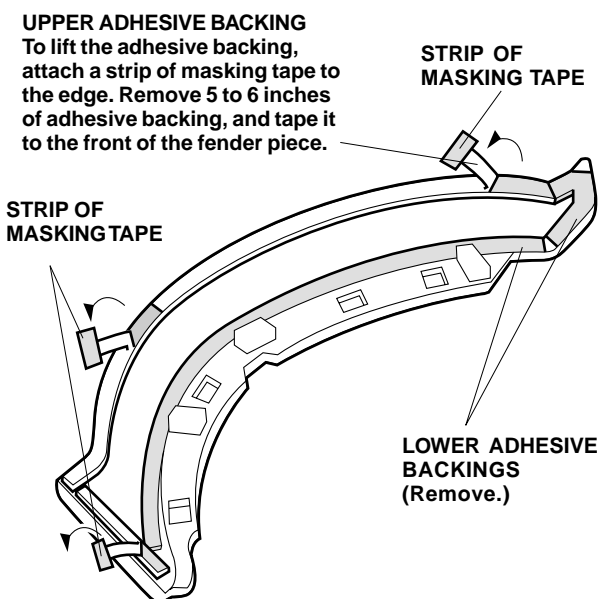

- Using isopropyl alcohol on a shop towel, clean the areas where the left front fender piece will attach.

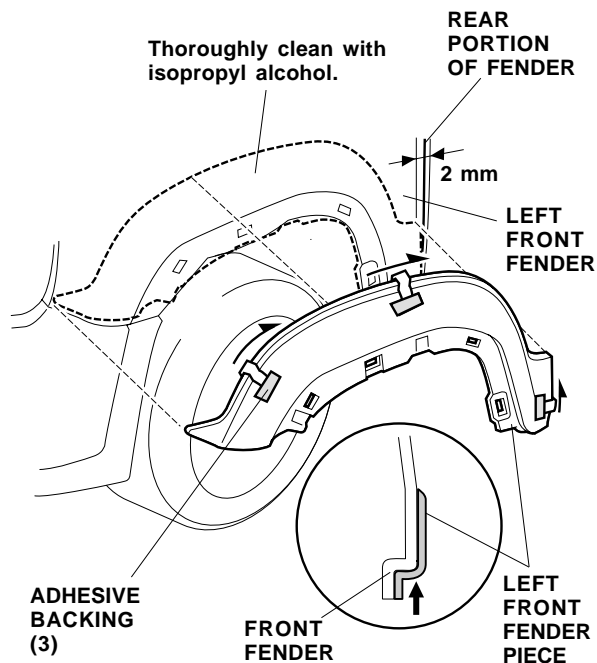

- Position the left front fender piece on the front fender. While holding pressure on the fender piece, carefully remove the adhesive backings from the fender piece. Take care not to tear the adhesive backings.
- Hold the fender piece firmly against the fender with the palm of your hand for 30 seconds.
- Reinstall the left front wheelwell protector. Be sure all retaining clips and tabs are securely fastened.

## Installing the Front Door Piece

- Remove the left front door mirror trim. Pull the top of the door mirror trim toward you to release the two clips. Take care not to damage the clips.

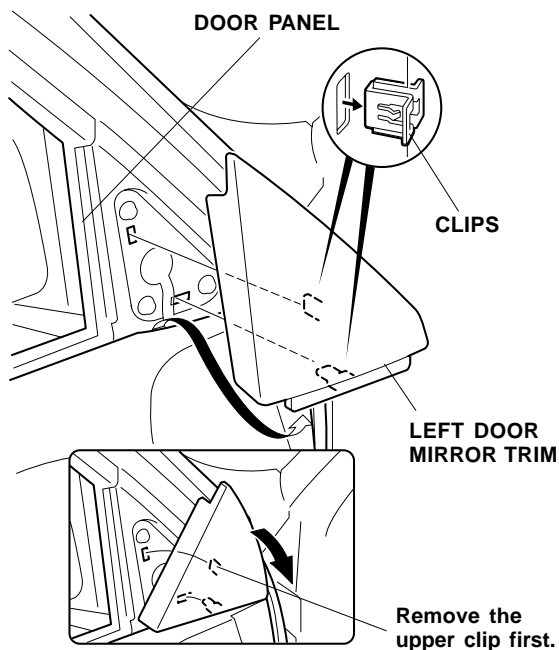

- Insert the end of a small flat-tip screwdriver into the groove of the inside handle case cover, and pry the cover up to release the three retaining tabs. Remove the cover.

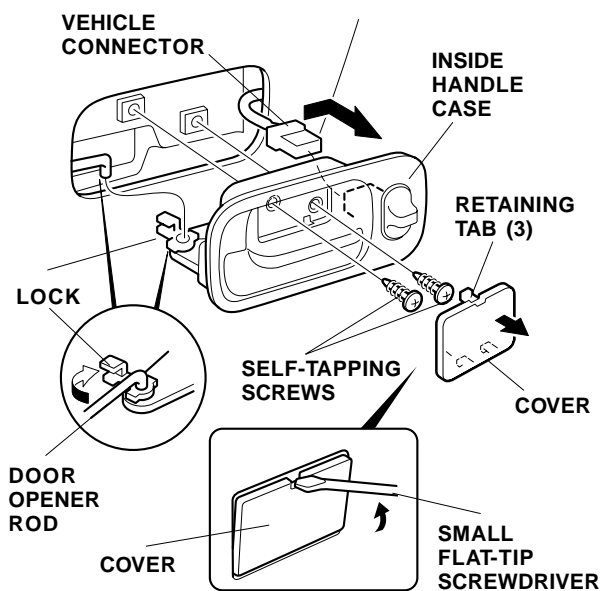

- Remove the two self-tapping screws that fasten the inside handle case. Disconnect the door opener rod, and unplug the vehicle connector. Remove the inside handle case from the door.

- Remove the one clip and two self-tapping screws that fasten the left front door panel, and pull the panel toward you to release the seven clips. Take care not to damage the clips.

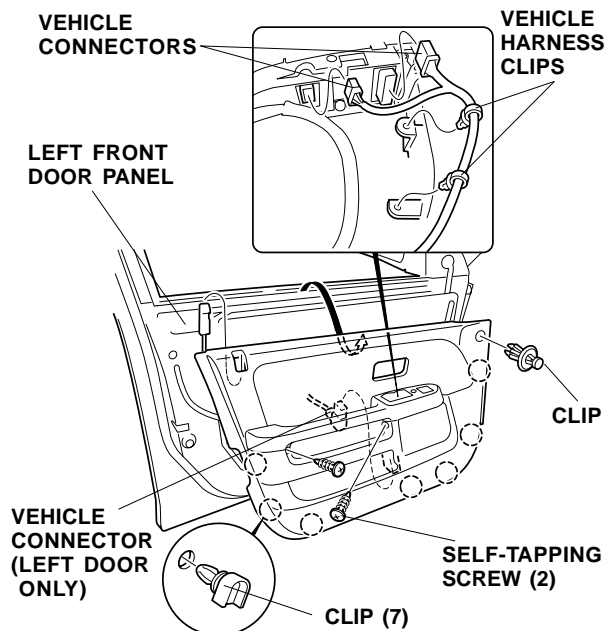

- Remove the vehicle harness from the left front door panel by releasing the two clips on the harness, unplug the connectors, and remove the door panel.
- Using a flat-tip screwdriver, press down on the upper clip on the speaker, and pull the top of the speaker out toward you. Unplug the vehicle connector, and remove the speaker.

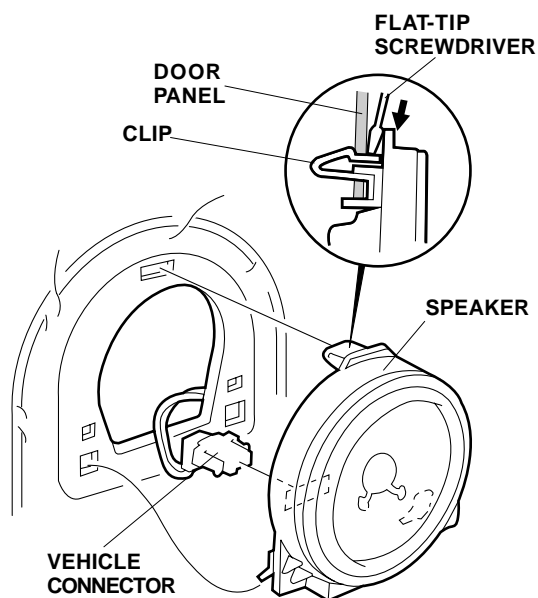

- Remove the bottom of the left front door plastic cover, and tape it up using masking tape. Take care not to allow the sealant to get on your skin or your clothes.

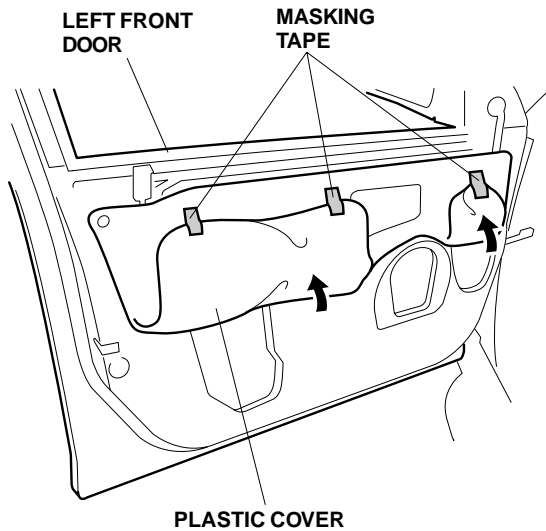

- On the inside of the left front door, squeeze the clips to remove the door molding. Start at one end, and push the clip while you pull on the molding to release the clip and the double-sided tape.

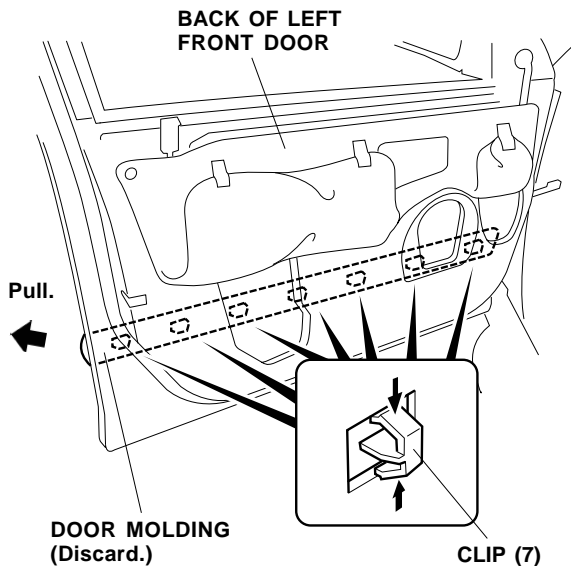

- Install seven clips on the left front door piece.

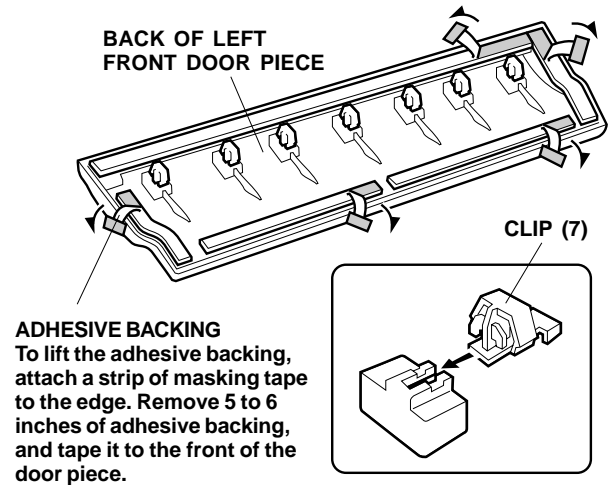

- Attach a strip of masking tape to the ends of the five adhesive backings on the left front door piece, and remove 5 to 6 inches of adhesive backing. Fold back the adhesive backing, and tape the ends to the front of the door piece.
- Using isopropyl alcohol on a shop towel, clean the area where the left front door piece will attach.

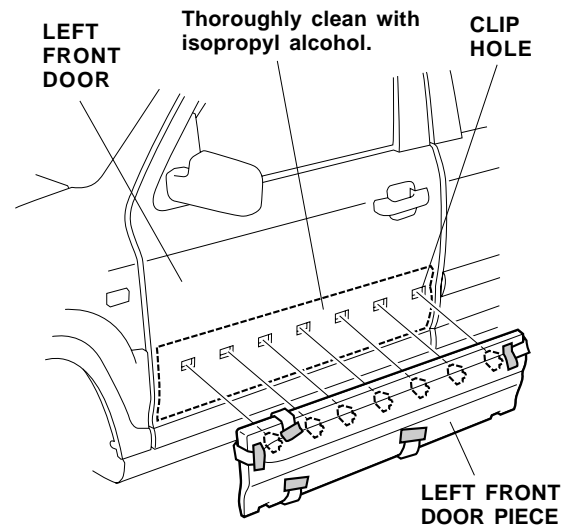

- Position the left front door piece on the left front door, and align the clips with the holes in the door panel.

24. Adjust the location of the door piece so that there is about 2 mm clearance between the ends of the door piece and the edges of the door. While holding pressure on the door piece, carefully remove the adhesive backings from the door piece. Take care not to tear the adhesive backings.

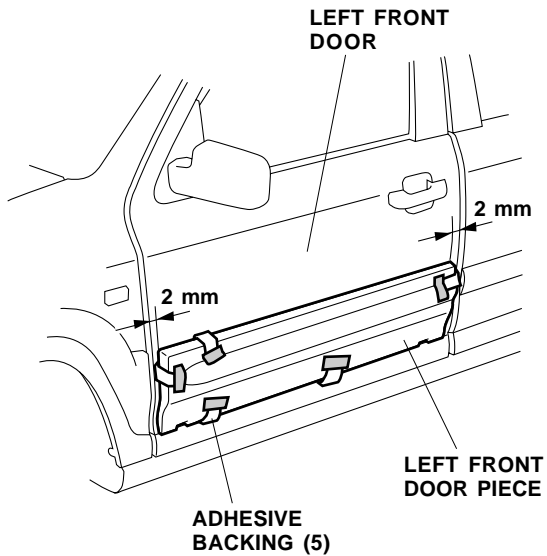

25. Using the palm of your hand, firmly push the door piece against the door in several places. Be sure all retaining clips and tabs are securely fastened.
26. Reinstall all removed parts. Check that all wire harnesses are routed properly and all connectors are plugged in.

### Installing the Rear Door Fender Piece

27. Gently pull the left rear door trim out toward you to release the one clip and remove the trim. Take care not to damage the clip.

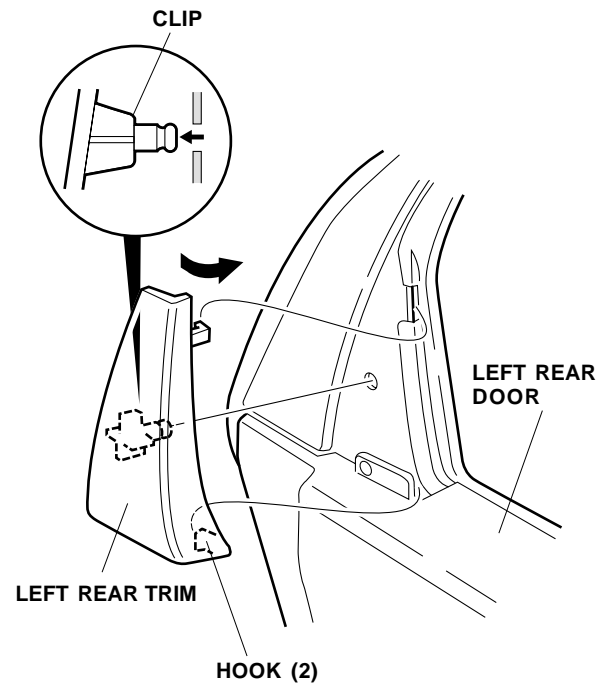

28. Insert the end of a small flat-tip screwdriver into the groove of the inside handle case cover, and pry the cover up to release the three retaining tabs. Remove the cover.

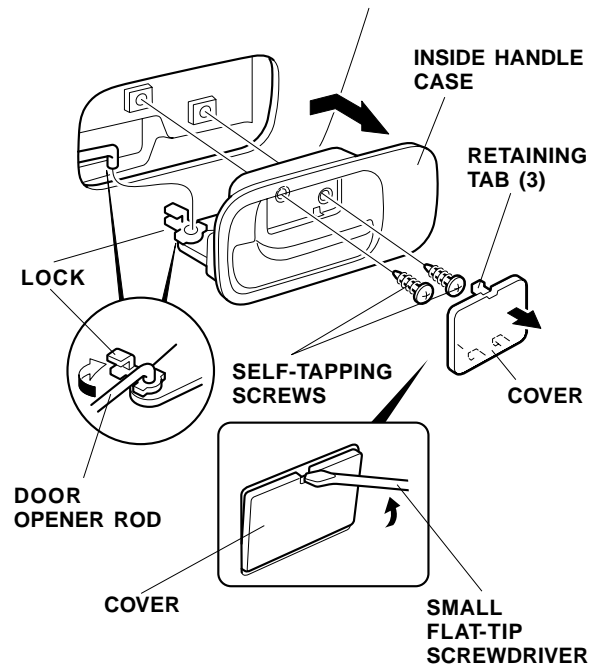

29. Remove the two self-tapping screws that secure the inside handle case, disconnect the door opener rod, and remove the handle case.

30. Remove the one clip and two self-tapping screws that fasten the left rear door panel, and pull the panel toward you to release the eight clips. Unplug the vehicle connector, and remove the panel.

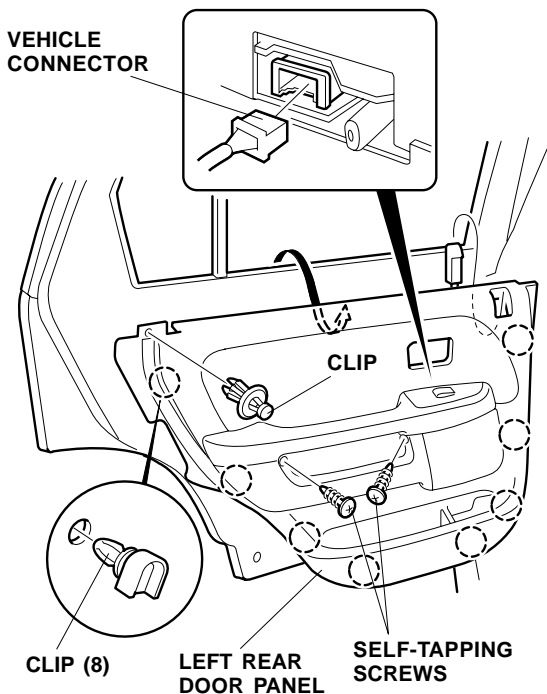

31. Remove the bottom of the left rear door plastic cover, and tape it up. Take care not to allow the sealant to get on your skin or your clothes.

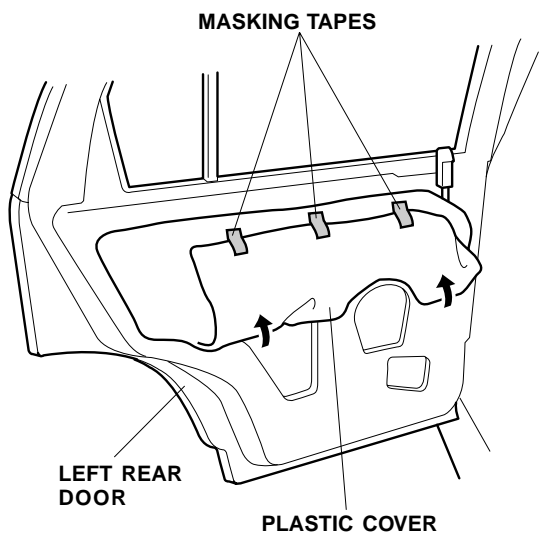

32. On the inside of the left rear door, squeeze the clips to remove the door molding. Start at one end, and push the clip while you pull on the molding to release the clip and the double-sided tape.

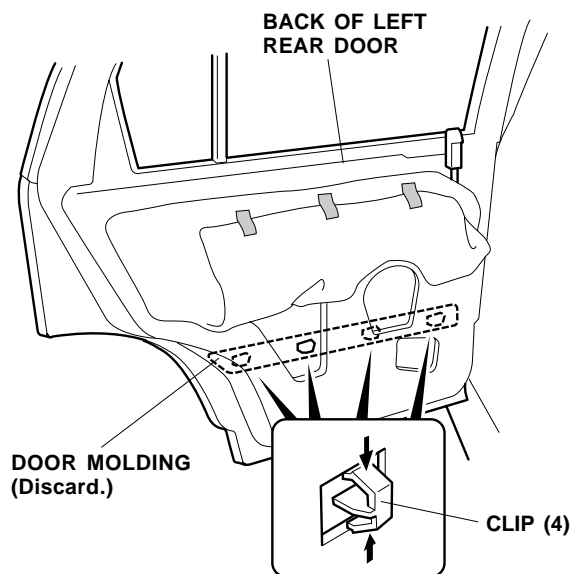

33. Install four clips on the left rear fender piece.

**ADHESIVE BACKING**

To lift the adhesive backing, attach a strip of masking tape to the edge. Remove 5 to 6 inches of adhesive backing, and tape it to the front of the fender piece.

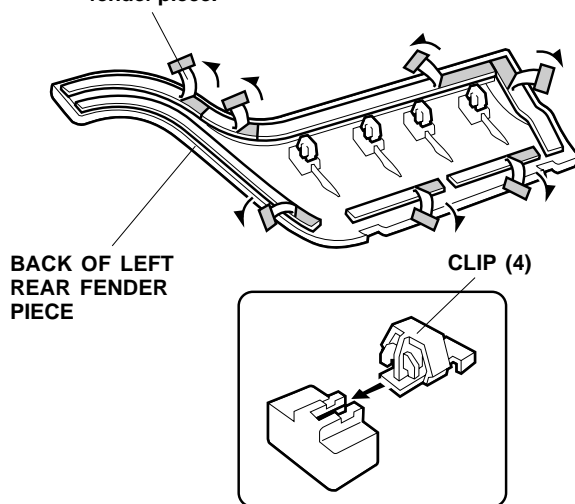

34. Attach a strip of masking tape to the ends of the seven adhesive backings on the left rear fender piece, and remove 5 to 6 inches of adhesive backing. Fold back the adhesive backing, and tape the ends to the front of the left rear fender piece.

35. Using isopropyl alcohol on a shop towel, clean the area where the left rear fender piece will attach.

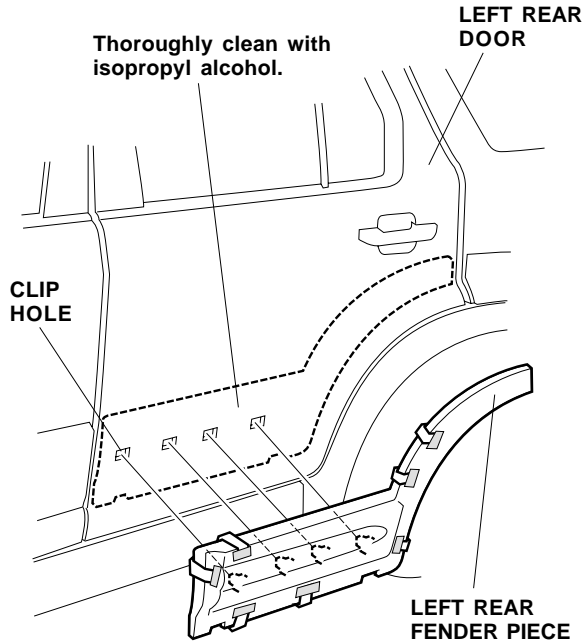

36. Position the left rear fender piece on the left rear door, and align the clips with the holes in the door panel.

37. Adjust the location of the left rear fender piece so that there is about 2 mm clearance between the ends of fender piece and the edges of the door. While holding pressure on the fender piece, carefully remove the adhesive backings. Take care not to tear the adhesive backings.

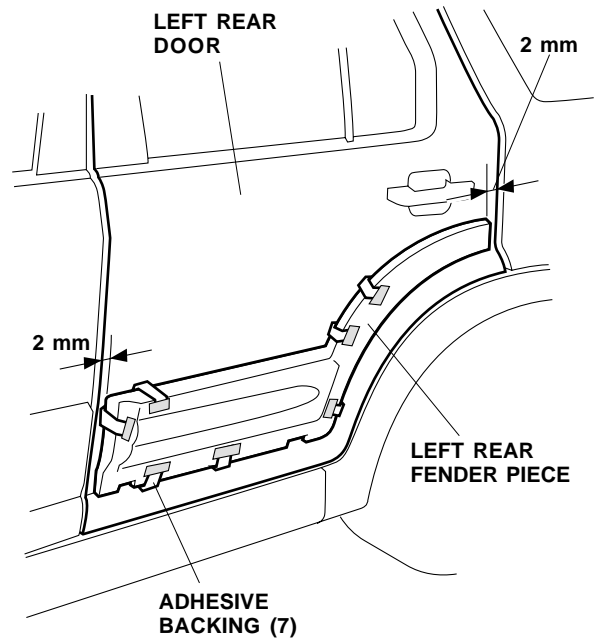

38. Using the palm of your hand, firmly push the door piece against the door in several places. Be sure all retaining clips and tabs are securely fastened.
39. Reinstall all removed parts. Check that all wire harnesses are routed properly and all connectors are plugged in.

## Installing the Rear Bumper Piece

40. Open the left rear door. Remove the one Torx bolt and three self-tapping screws that fasten the left rear wheelwell protector. Pull the left wheelwell protector toward you to release the six clips, and remove the wheelwell protector. Take care not to damage the clips.

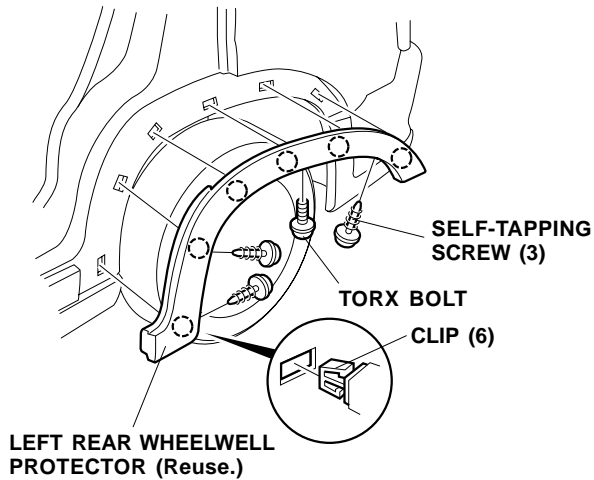

41. Temporarily position the left rear bumper piece on the left rear fender, and adjust it so that there is about 2 mm clearance at each end of the fender piece. Bring the step in left rear bumper piece into contact with the step in the rear fender. Remove the left rear bumper piece.

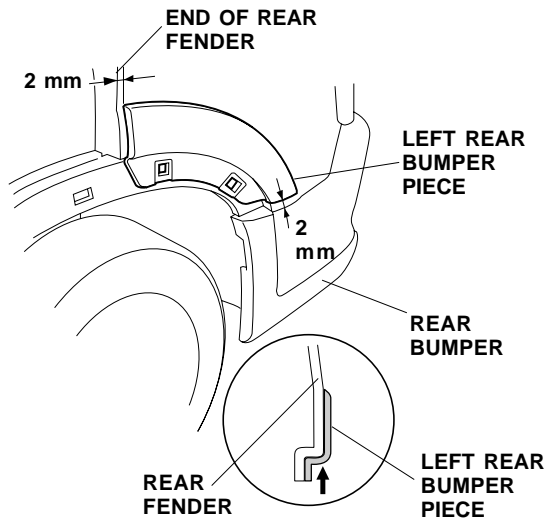

42. Remove the lower adhesive backing from the left rear bumper piece. Attach a strip of masking tape to the ends of the two remaining adhesive backings on the bumper piece, and remove 5 to 6 inches of adhesive backing. Fold back the adhesive backing, and tape the ends to the front of the left rear bumper piece.

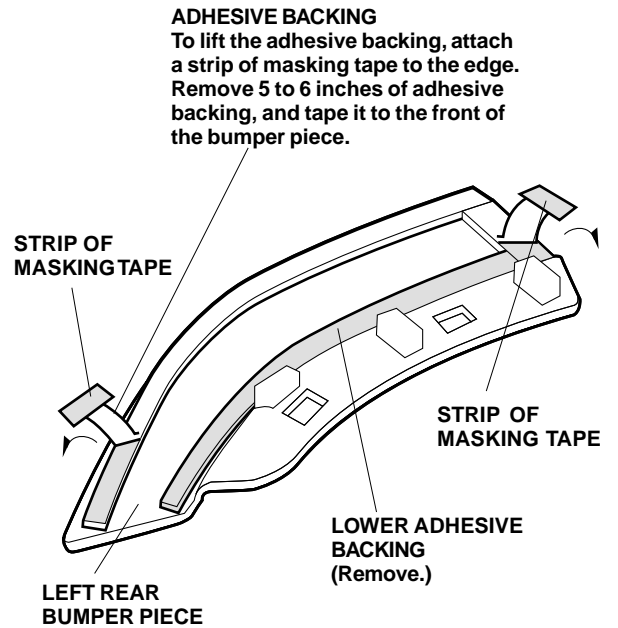

43. Using isopropyl alcohol on a shop towel, clean the area where the left rear bumper piece will attach.
44. Position the left rear bumper piece on the rear fender. While holding pressure on the bumper piece, carefully remove the adhesive backings. Take care not to tear the adhesive backings.

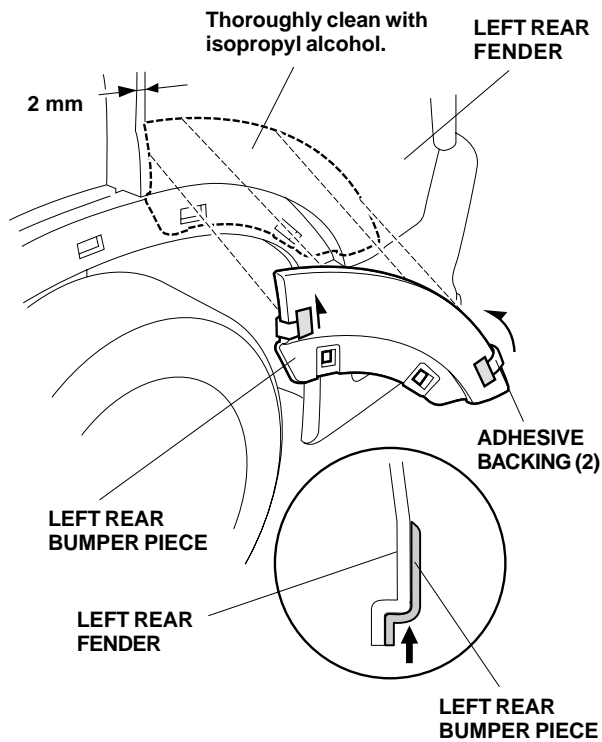

45. Using the palm of your hand, hold the bumper piece firmly against the rear fender for 30 seconds.
46. Reinstall the left rear wheelwell protector. Be sure all retaining clips and tabs are securely fastened.

47. Repeat steps 3 through 46 to install the pieces on the right side of the vehicle.
48. Reconnect the negative cable to the battery.
49. Reset the clock and the radio station presets.

NOTE: Whenever the battery is disconnected, the driver's window AUTO function is disabled.

50. Start the engine. Push down on the driver's window switch until the window is fully open.
51. Pull up on the driver's window switch to close the window completely, then hold the switch for a second or two more.
52. Test the AUTO window function.