

<http://www.HandA-Accessories.com>

203

HONDA INSTALLATION INSTRUCTIONS	Accessory OPTIONAL TRAILER HITCH WIRING KIT P/N 08L92-S0X-100R1	Application CR-V	Publications No. All 23136
			Issue Date JAN 2002

PARTS LIST

Optional harness

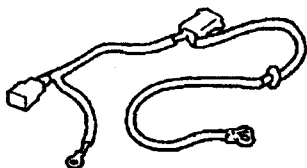

3 Wire ties



3 Cushion tapes (2 not used)



6 Bolts, 12 mm (not used)



6 Flat washers, 12 mm (not used)



6 Lock washers, 12 mm (not used)



Bolt, 6 mm (not used)



Nut, 6 mm (not used)



TOOLS AND SUPPLIES REQUIRED

- Phillips screwdriver
- Flat-tip screwdriver
- 10 mm Socket
- Shop towel
- Diagonal cutters
- Isopropyl alcohol

INSTALLATION

Customer Information: The information in this installation instruction is intended for use only by skilled technicians who have the proper tools, equipment, and training to correctly and safely add equipment to your vehicle. These procedures should not be attempted by "do-it-yourselfers."

1. Write down the customer's radio station presets; the radio memory will be erased when you disconnect the battery.
2. Disconnect the negative cable from the battery.
3. Open the tailgate.

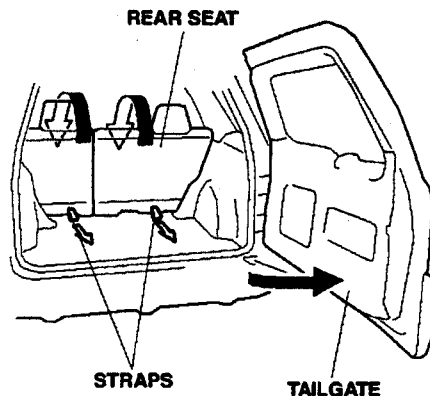

4. Fold down the rear seat.
5. Turn over the cargo area mat, and remove the cargo area floor. Remove the cargo storage bin.

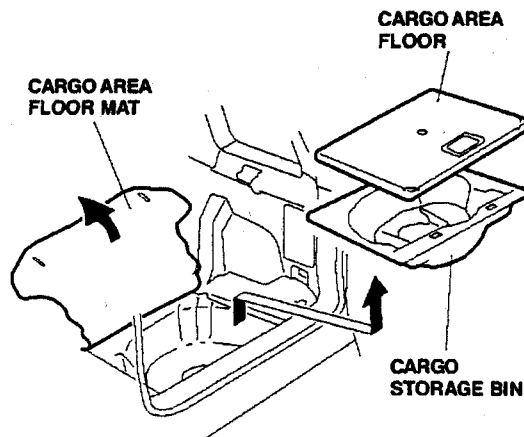

6. Remove the tailgate weatherstrip, and remove the two clips from the rear trim panel. Pry up on the five clips and remove the rear trim panel.

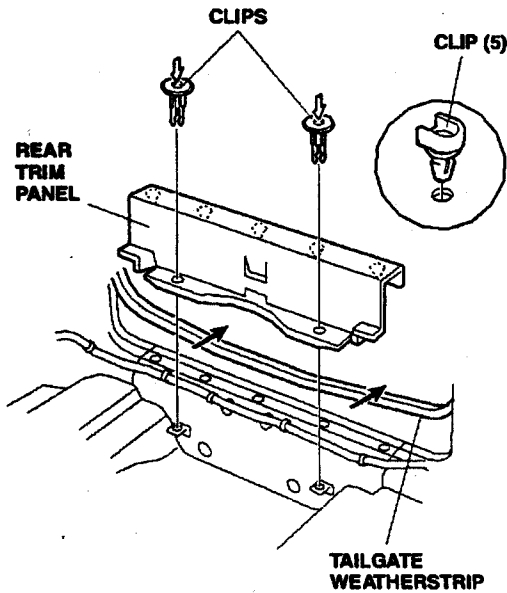

7. Remove the left rear door sill trim (three clips).

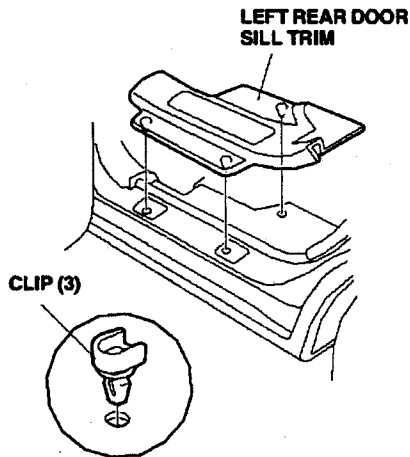

8. Remove left rear side trim panel:

- Remove the bolt that secures the tie-down hook to the left rear side trim panel, and remove the tie-down hook.

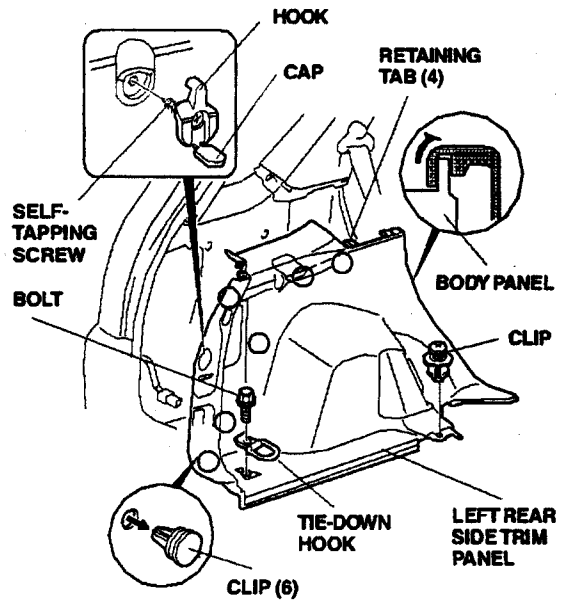

- Open the cap, and remove the self-tapping screw securing the hook. Remove the hook.
- Remove the clip, and remove the trim panel from the body panel starting at the front. Pull the trim panel out toward you to release the six clips and four retaining tabs, unplug the accessory socket and remove the trim panel.

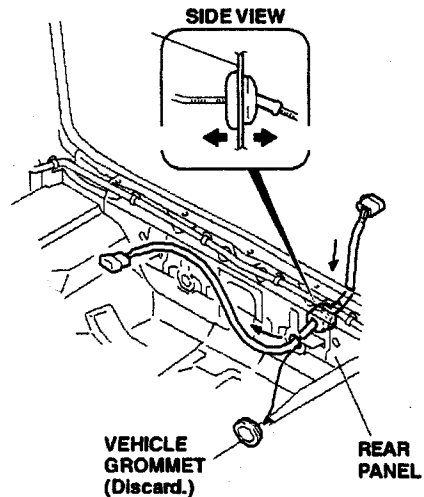

- Remove and discard the rubber grommet located on the left side of the rear panel.

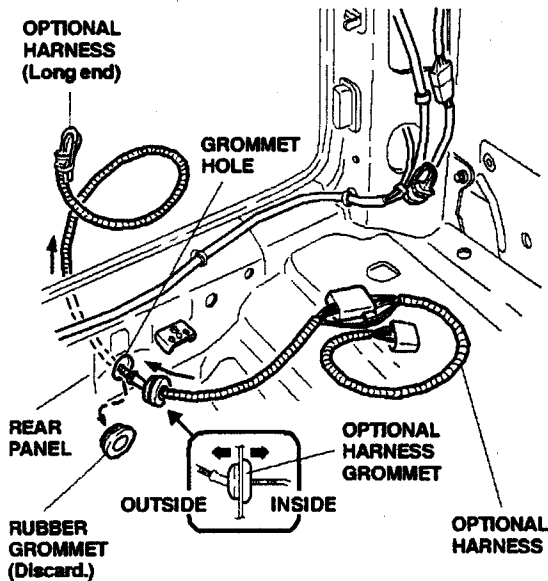

- Get the optional harness. Route the long end of the optional harness through the grommet hole in the rear panel. Seat the optional harness grommet securely in the grommet hole.
- At the left rear corner of the cargo area, locate the 6-pin connector blue-taped to the vehicle harness. Remove the blue tape to free the harness.

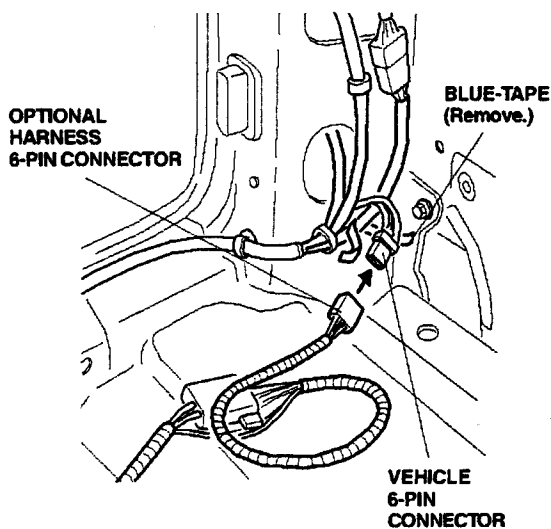

- Plug the 6-pin connector of the optional harness into the vehicle 6-pin connector.

- Near the connector, locate and remove the body panel bolt from the lower rear corner.

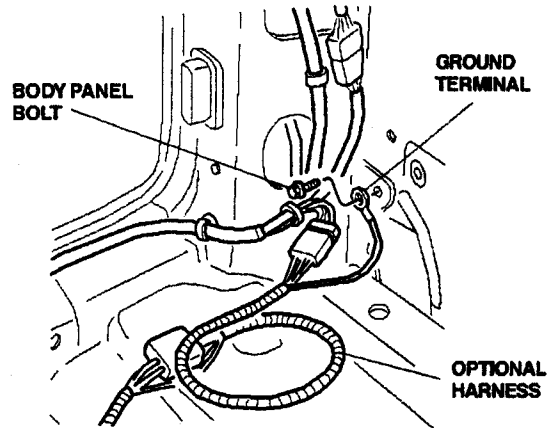

- Using the body panel bolt, attach the ground terminal from the optional harness to the body. Tighten the bolt securely.
- Route the optional harness along the vehicle harness and toward the grommet hole.

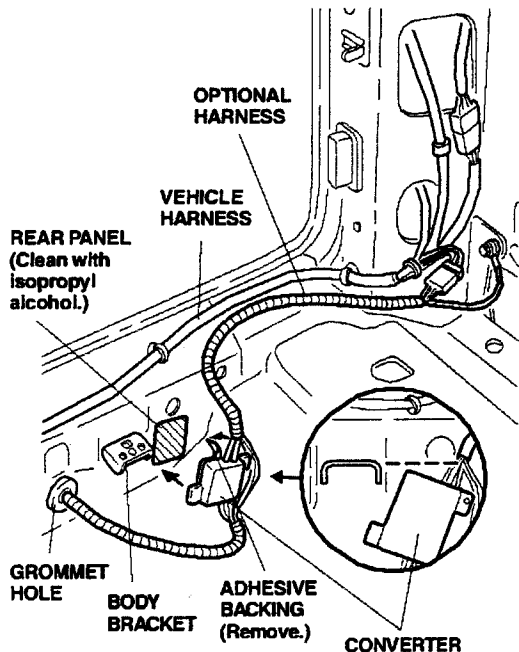

- Near the body bracket, use isopropyl alcohol to clean the area where the converter will attach.
- Remove the adhesive backing and attach the converter to the body next to the body bracket. Make sure the top of the converter is below the bracket.

18. Secure the optional harness to the vehicle harness with two wire ties in the area shown. Wrap one cushion tape around the 6-pin connector.

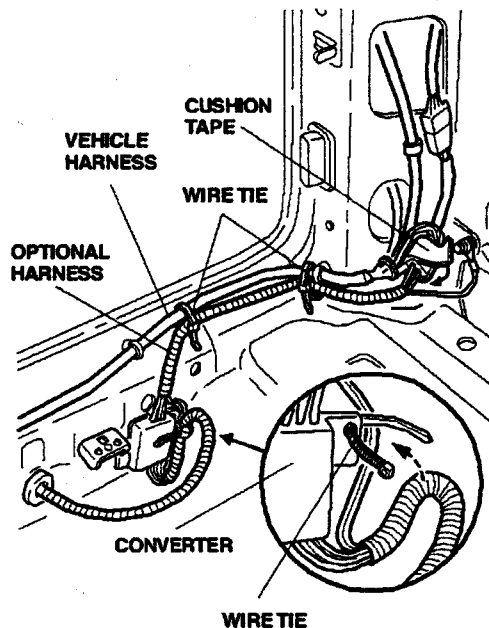

19. At the converter, secure the excess harness to the converter with one wire tie. Cut the excess off of the wire ties.

20. Reinstall all of the interior trim pieces.

21. On the outside of the vehicle, pull the excess harness from under the bumper area. Bundle up the excess harness, and wire tie the excess harness under the vehicle. You can also cut the harness to the proper length, and then wire tie the excess harness under the vehicle.

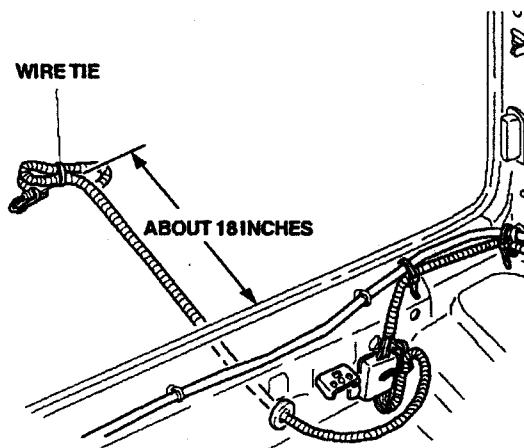

22. Reconnect the negative battery cable.
 23. Reset the clock and the radio station presets.
 24. Reinstall all removed parts.

NOTE: Whenever the battery is disconnected, the driver's AUTO function is disabled.

25. Start the engine. Push down on the driver's window switch until the window is fully open.
 26. Pull up on the driver's window switch to close the window completely, then hold the switch for a second or two more.
 27. Test the AUTO window function.