



# INSTALLATION INSTRUCTIONS

Accessory  
**ARMREST CONSOLE**

Application  
**CR-Z**

Publications No.  
**All 43552**  
Issue Date  
**AUG 2010**

## PARTS LIST

Armrest console

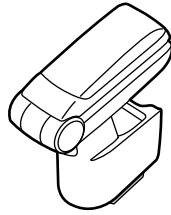

Armrest bracket

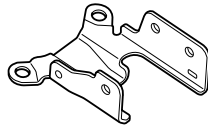

2 Collars



4 Washer-bolts



2 Caps



Urethane tape



Wire tie

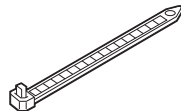

Accessory User's Information Manual

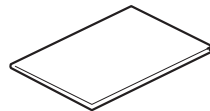

## TOOLS AND SUPPLIES REQUIRED

Phillips screwdriver

Flat-tip screwdriver

10 mm and 17 mm Open end wrenches

10 mm and 12 mm Sockets

Ratchet

Torque wrench

Pushpin

Drill

3 mm, 10 mm, and 13 mm Drill bits

20 mm Hole saw

File

Isopropyl alcohol

Shop towel

Tape Measure

Scissors

Masking tape

Diagonal cutters

Trim Tool Set (SOJATP2014)

(Available through the Honda Tool and Equipment program. On the iN, click on: Service/Service Bay/Tool and Equipment Program, then enter the number under "Search." Or call 888-424-6857.)

Eye protection (face shield, safety goggles, etc.)

### ***Illustration of the Armrest Console Installed on the Vehicle***

**ARMREST CONSOLE**

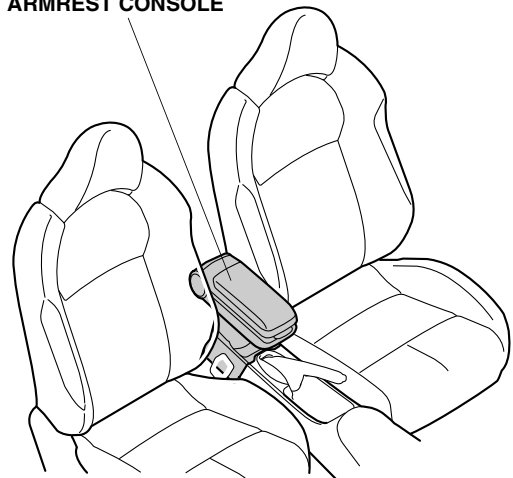

## INSTALLATION

**Customer Information:** The information in this installation instruction is intended for use only by skilled technicians who have the proper tools, equipment, and training to correctly and safely add equipment to your vehicle. These procedures should not be attempted by “do-it-yourselfers.”

1. Make sure you have the anti-theft code for the audio unit and navigation system (if equipped), then write down the radio station presets.
2. Disconnect the negative cable from the battery.
3. Remove the center lower lid (five retaining tabs, three hooks, and unplug the vehicle connector).

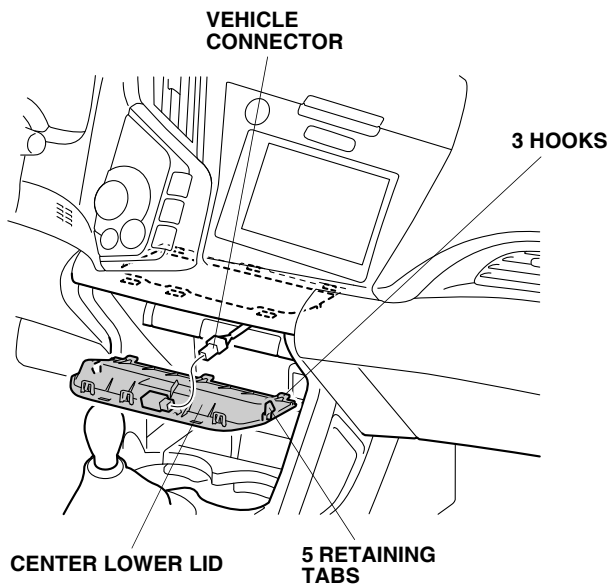

4. Insert your hand into the center lower lid opening, and push on the center trim to release the three clips.

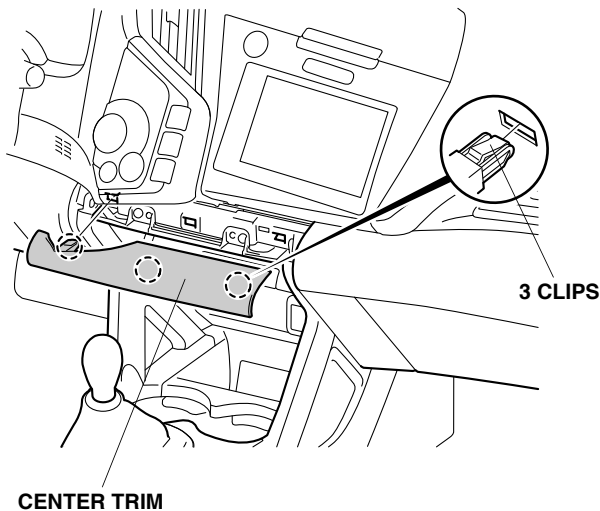

If the vehicle is equipped with a M/T, continue with step 5; if the vehicle is equipped with a CVT, go to step 10.

### Base Model

5. Push down on the ring to release the two retaining tabs.

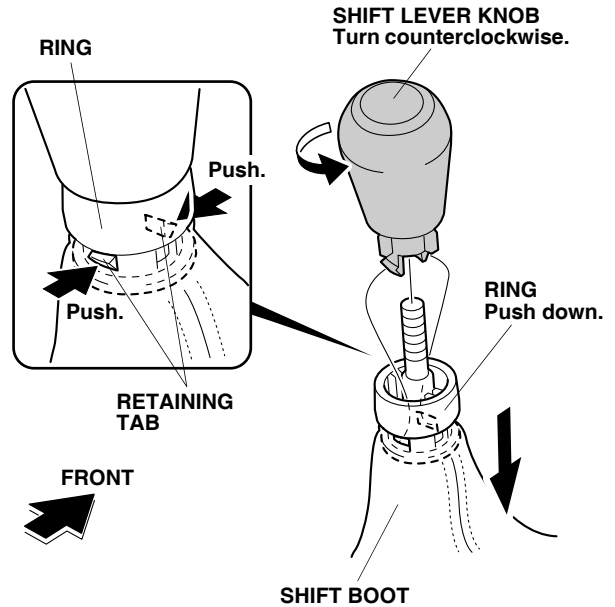

6. Turn the shift lever knob counterclockwise and remove it from the shift lever. Go to step 9.

**EX Model**

- Turn the shift lever knob counterclockwise, and remove it from the shift lever.

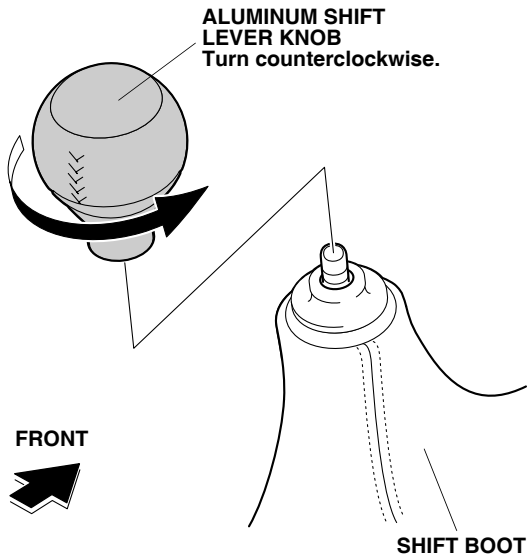

- Push down the ring. Using a 17 mm wrench, remove the lock nut.

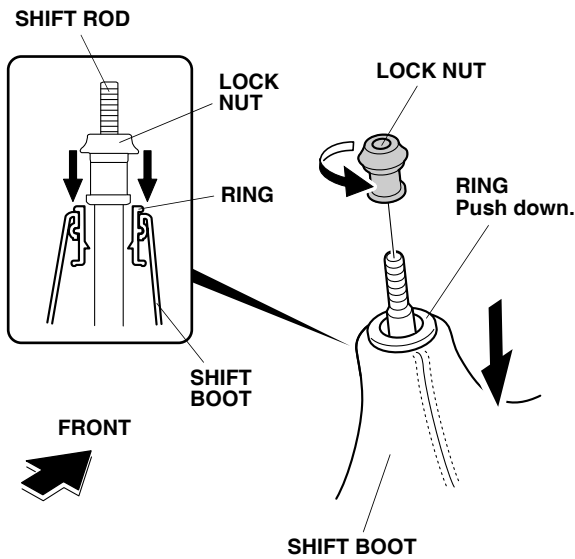

- Using a trim tool, remove the shift trim (six clips and two retaining tabs). Go to step 12.

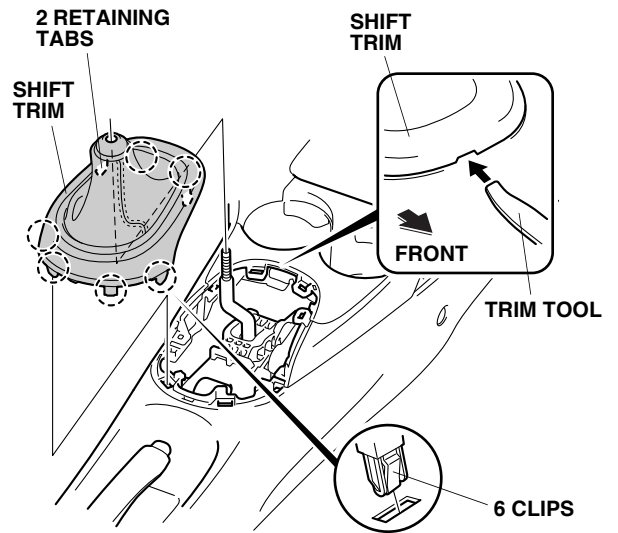

- With the parking brake fully applied, move the select lever to the "D" position.

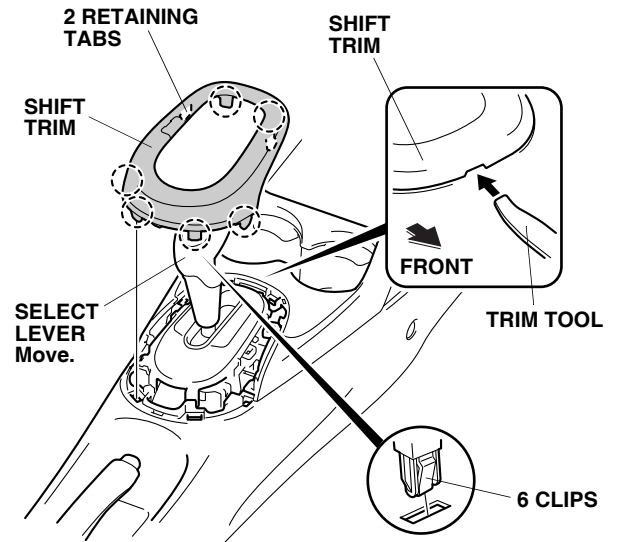

- Using a trim tool, remove the shift trim (six clips and two retaining tabs).

12. Remove the cup holder trim (five clips).

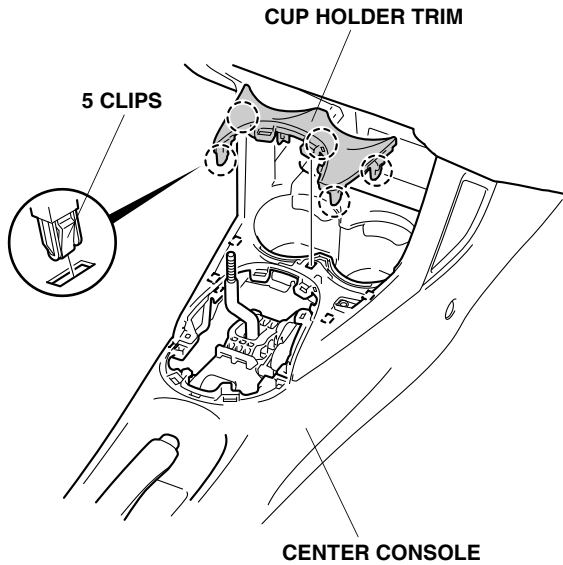

13. Attach the masking tape to the right console side trim and the left console side trim as shown.

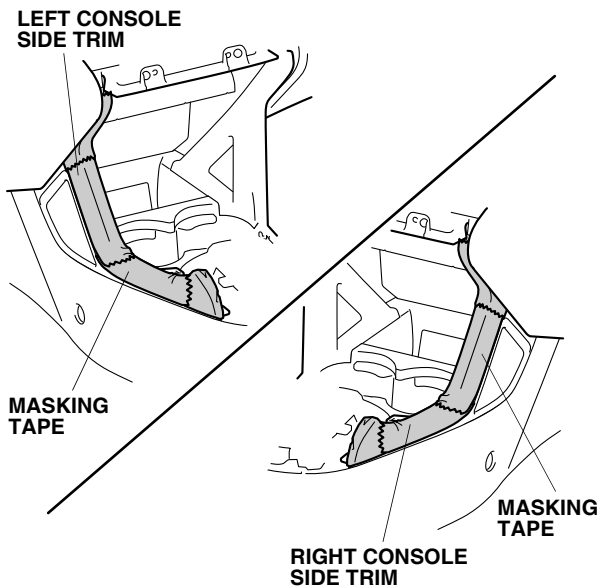

14. Remove the three self-tapping screws that secure the right console side trim. Pull the console trim straight out to release the four clips and four hooks.

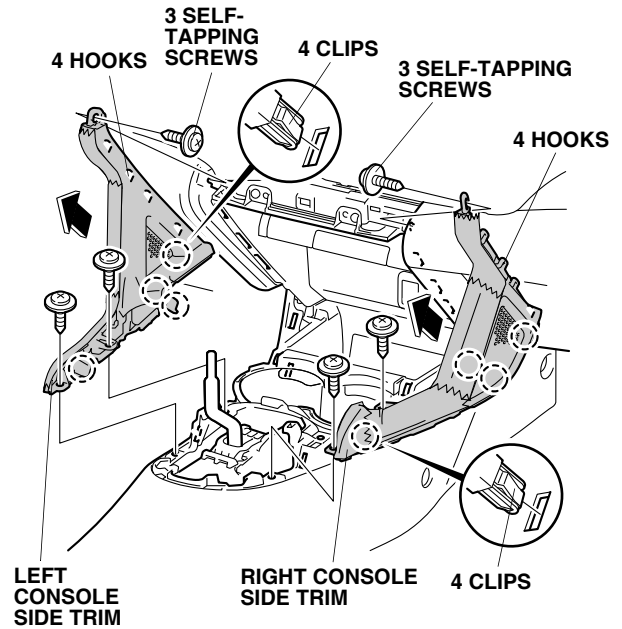

15. Remove the left console side trim the same way.  
 16. Pull the parking brake lever fully. Remove the parking brake lever trim (four retaining tabs).

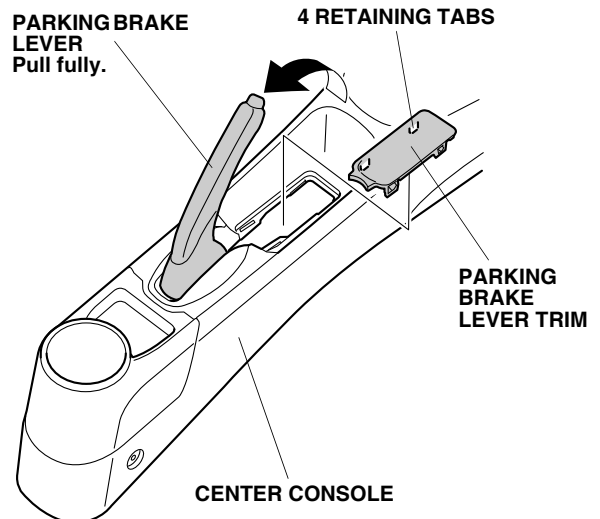

17. Locate the slot on the right side of the rear console. Using a flat-tip screwdriver wrapped with masking tape, pry up to remove the rear console (seven clips). Be careful not to damage the center console.

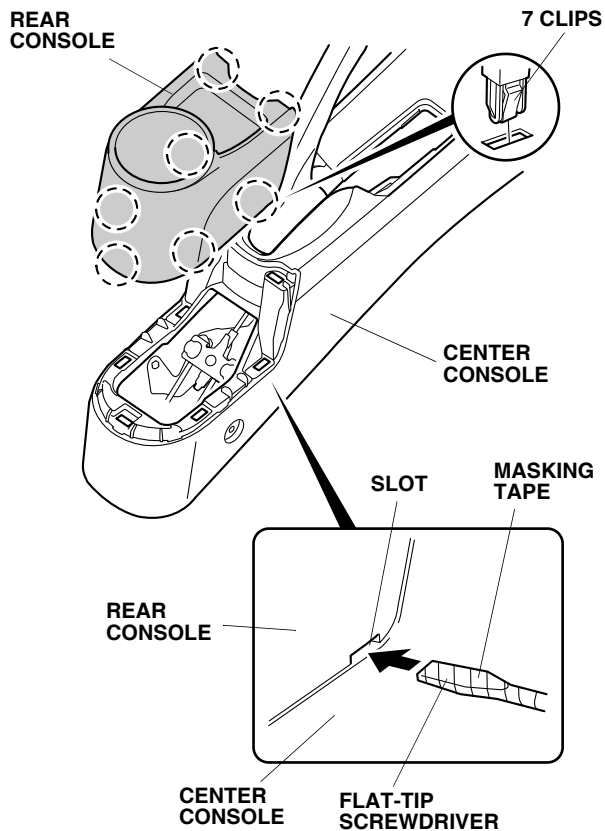

18. Remove the center console (four self-tapping screws, four clips, and one clip).

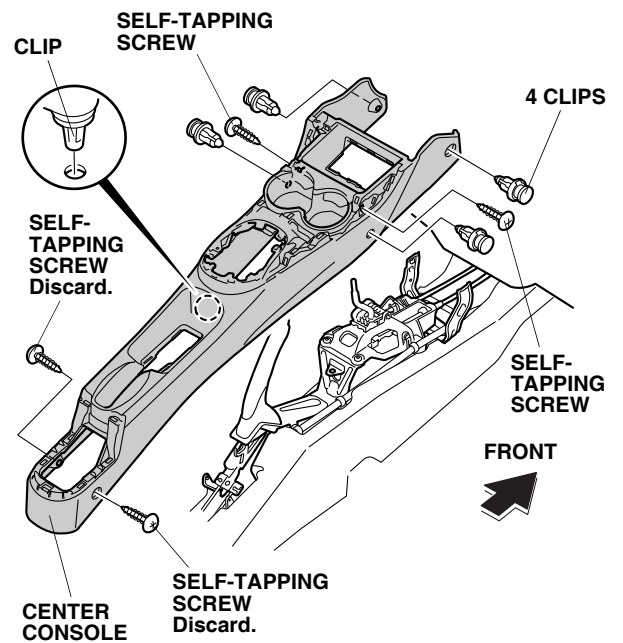

19. Unplug the vehicle connector from the parking brake lever.

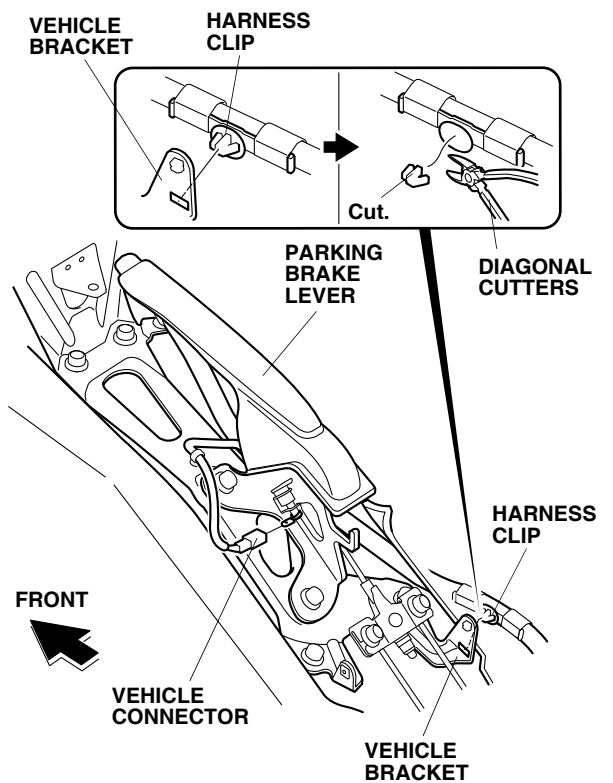

20. Remove the harness clip from the vehicle bracket, and cut the harness clip as shown.

21. Remove and discard the two screw grommets from the vehicle bracket.

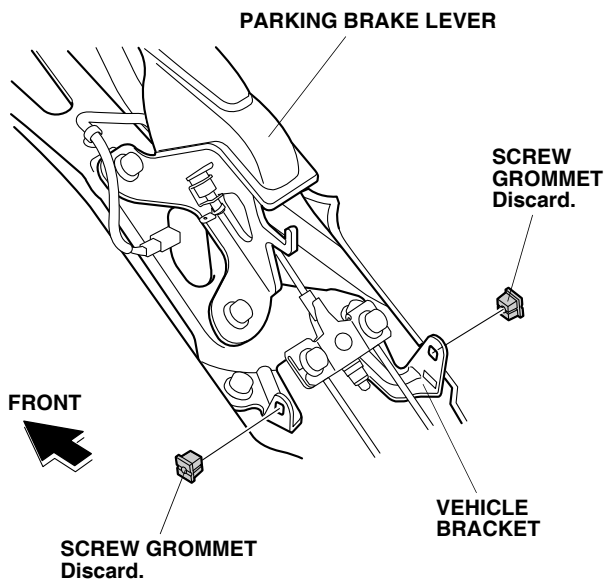

22. Move the shift lever to the "P" position (CVT model) or to the 1st gear position (M/T model) and block the wheels, then release the parking brake. Remove the two bolts from the parking brake lever.

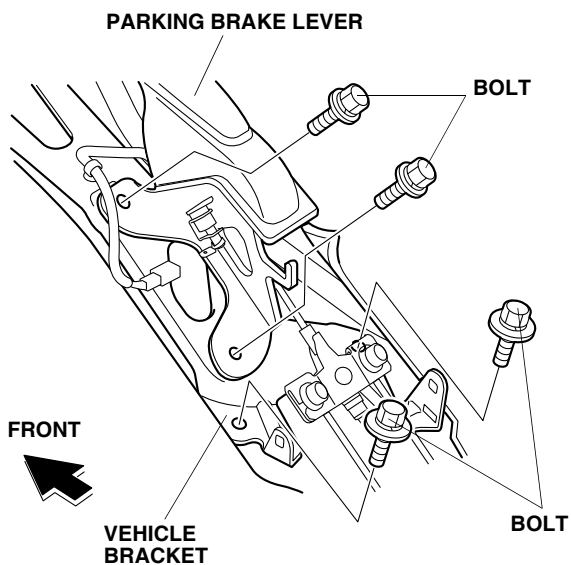

23. Remove the two bolts from the vehicle bracket.

## Installing the Armrest Console

24. Using isopropyl alcohol on a shop towel, thoroughly clean the armrest bracket where the urethane tape will attach.

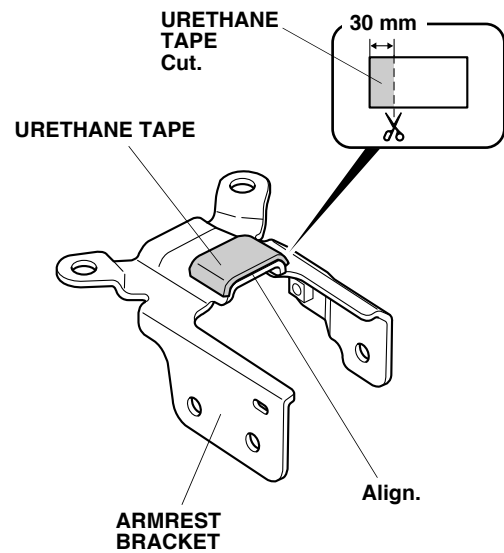

25. Using scissors, measure and cut 30 mm off the end of one urethane tape as shown. Attach the 30 mm piece of urethane tape to the armrest bracket as shown.
26. Position the armrest bracket under the parking brake cables.

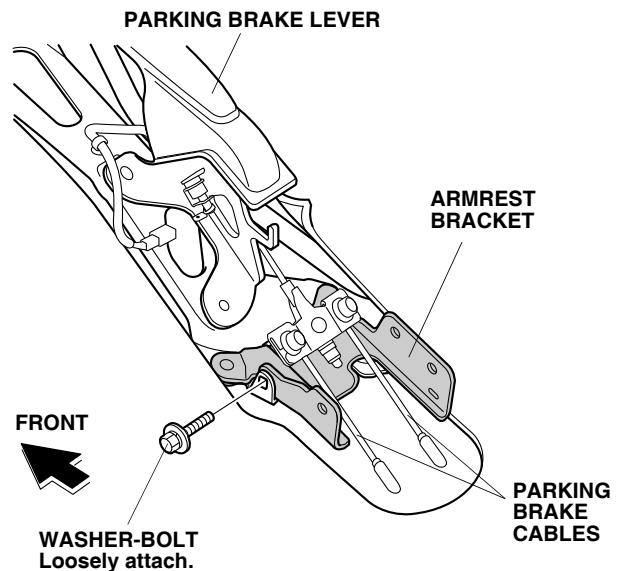

27. Loosely attach the bracket to the vehicle bracket with one washer-bolt supplied.

28. Secure the armrest bracket to the vehicle bracket with the two bolts removed in step 23. Make sure the holes in the armrest bracket align with the vehicle bracket. Torque the vehicle bracket bolts to 22 N·m (16 lbf·ft).

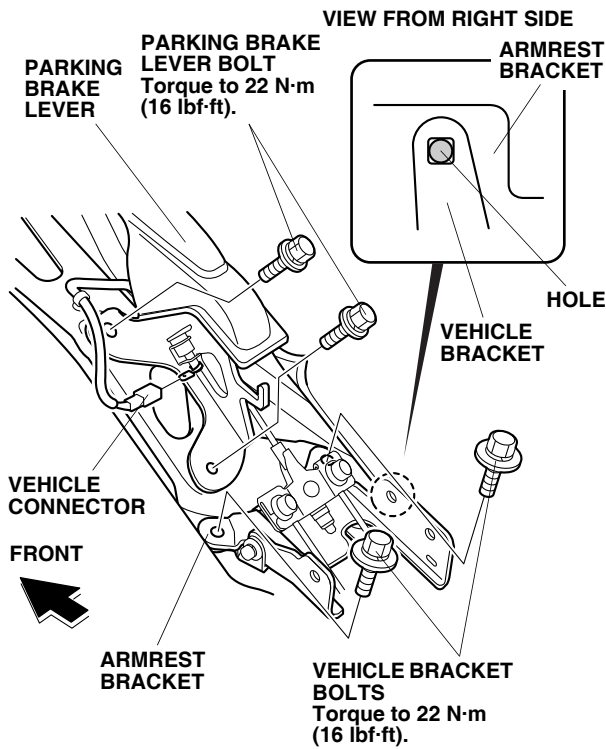

29. Reinstall the parking brake lever with the two bolts removed in step 22. Torque the parking brake lever bolts to 22 N·m (16 lbf·ft).
30. Plug the vehicle connector into the parking brake lever.

31. Measure and cut a 10 mm slit in the floor carpet as shown. Be careful not to damage the vehicle harness under the floor carpet.

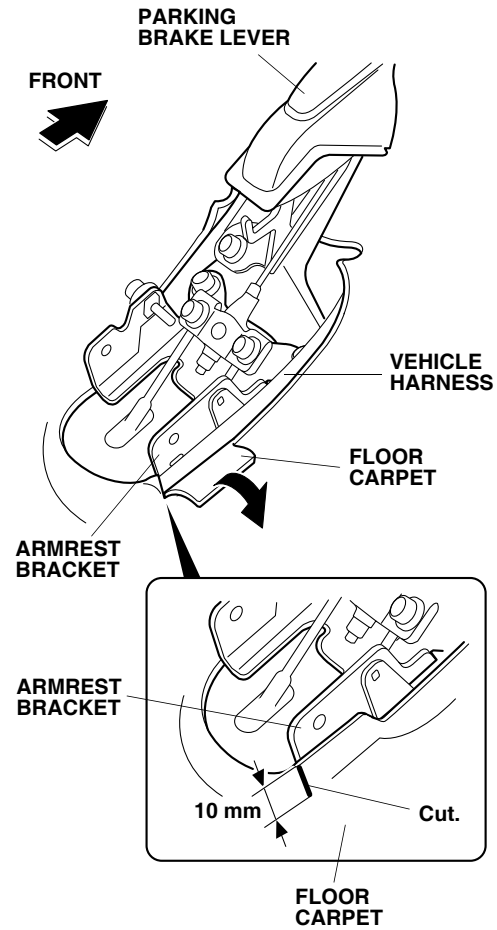

32. Secure the vehicle harness to the armrest bracket with one wire tie as shown.

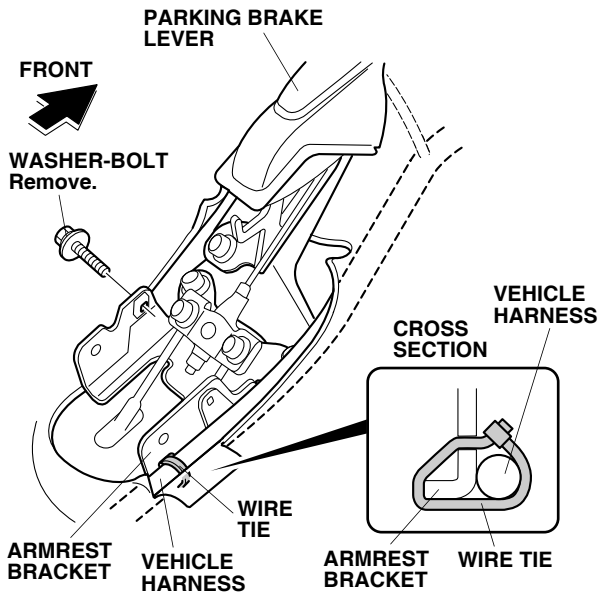

33. Remove the washer-bolt that was loosely installed in step 27.

34. Using a pushpin, pierce the two scribe marks on the inside of the center console.

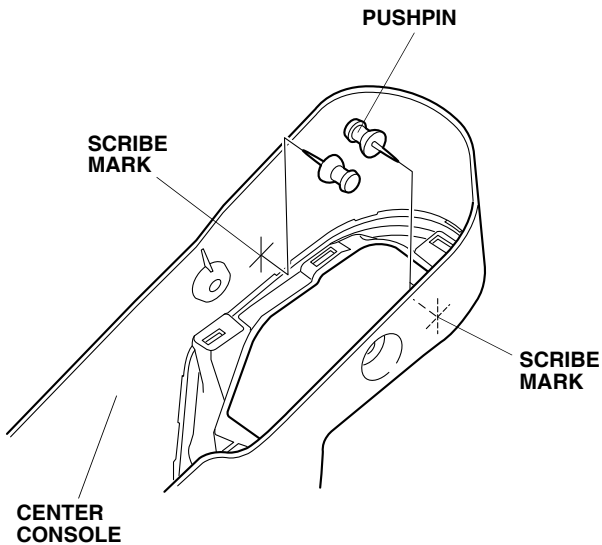

35. While wearing eye protection, drill each pierced mark on the center console to 20 mm. First drill with a 3 mm drill bit, and finish with a 20 mm hole saw. Remove any burrs.

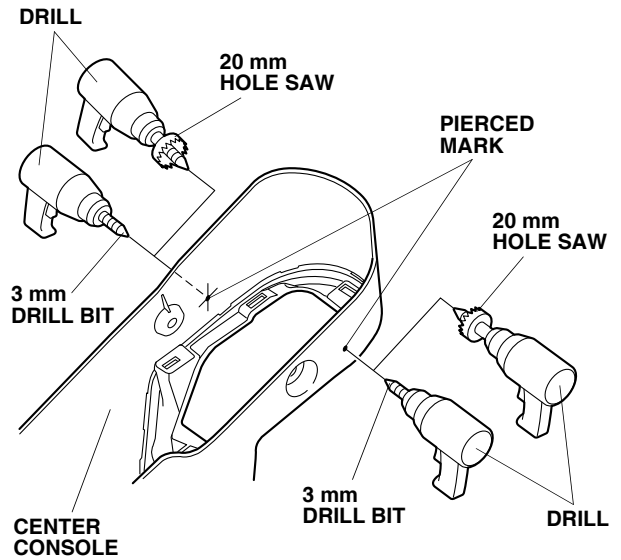

36. While wearing eye protection, enlarge the two holes on the center console to 13 mm. First drill with a 10 mm drill bit, and finish with a 13 mm drill bit. Remove any burrs.

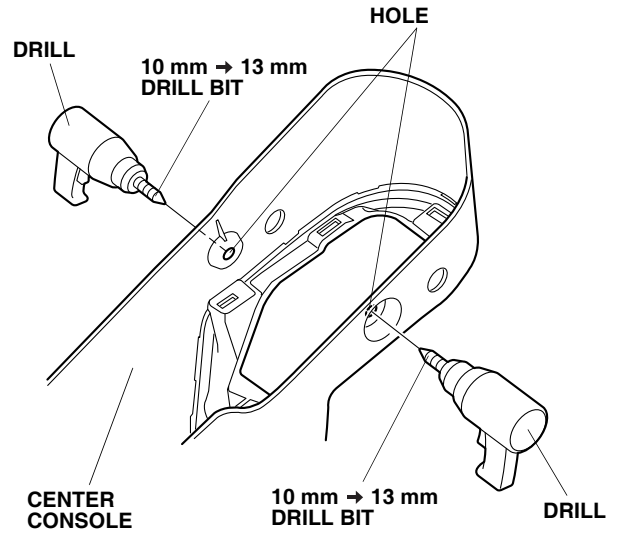

37. With the parking brake fully applied, reinstall the center console. If the vehicle is a CVT model, move the shift lever to the "D" position.

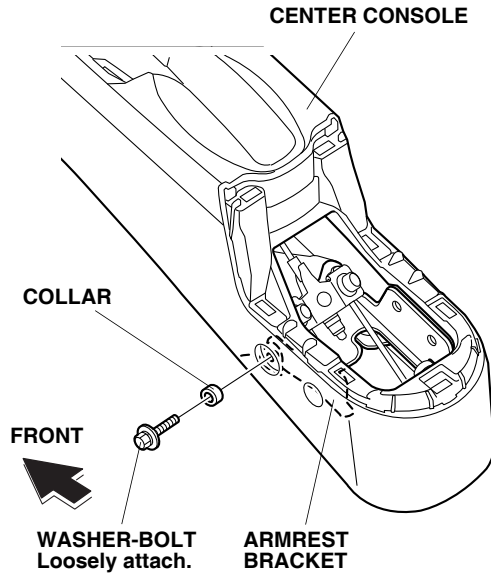

38. Loosely attach the center console to the armrest bracket with one washer-bolt and one collar.
39. Install the armrest console to the center console with the seven clips.

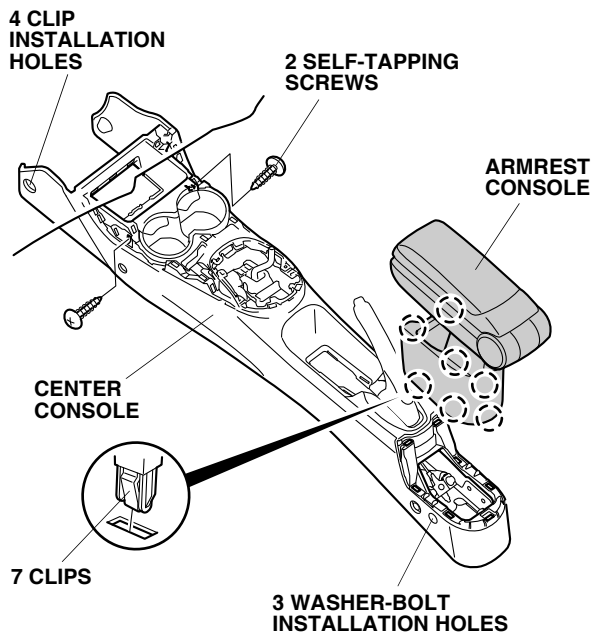

40. Secure the center console with the two self-tapping screws. Make sure that installation holes for the clips and the washer-bolts are aligned.

41. Loosely attach the armrest console to the armrest bracket with an additional washer-bolt and a collar.

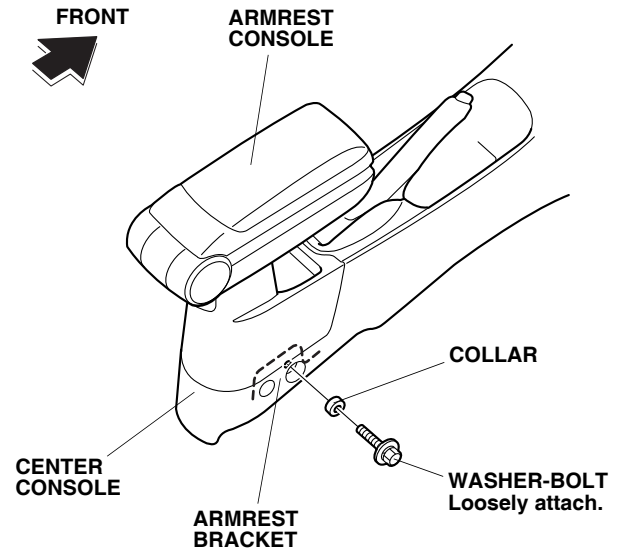

42. Loosely attach the armrest console to the armrest bracket with the two additional washer-bolts.

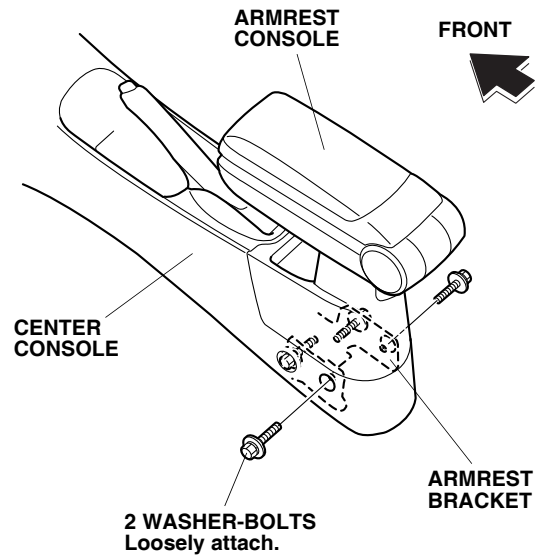

43. While pressing the armrest console down against the center console, tighten the four washer-bolts. Make sure that there is no clearance between the armrest console and center console. Torque all four washer-bolts to 12 N·m (9 lbf·ft).

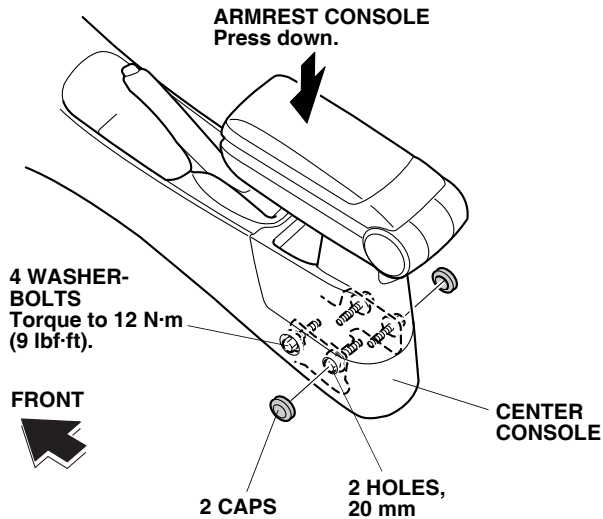

44. Install the two caps over the two 20 mm holes on the center console.
45. Check that all wire harness are routed properly and all connectors are plugged in.
46. Reconnect the negative cable to the battery.
47. Enter the customer's anti-theft code for the audio unit and navigation system (if equipped), and reset the radio station presets.
48. Reset the clock.
49. Reinstall all removed parts.
50. If the IMA battery level gauge display is at zero, start the engine, and hold it between 3,500 rpm and 4,000 rpm (without load) in P or N position until the IMA battery level gauge display shows at least half-charged.