



INSTALLATION INSTRUCTIONS

Accessory TAILGATE CABANA P/N 08Z04-SCV-100	Application ELEMENT	Publications No. All 24317
		Issue Date DEC 2002

Keep this information in the glove box for future reference.

PARTS LIST

Tailgate Cabana
(with storage bag)

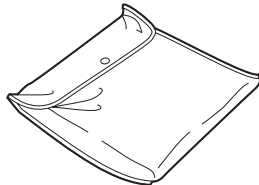

2 Shock cord poles

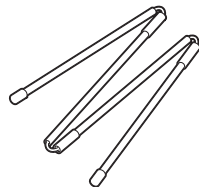

INSTALLATION

NOTE:

- Never start or run the vehicle's engine when the tailgate cabana is installed.
- To avoid running the battery down, turn the interior lights off when the tailgate is open.
- The tailgate cabana is designed to provide shade and privacy while the vehicle is parked. It is not intended to be used in the rain or during high winds or when the vehicle is moving.

1. Remove the tailgate cabana from the storage bag and drape it over the top of the upper tailgate.

NOTE: If an upper tailgate deflector is installed, position the pockets to the rear of the deflector.

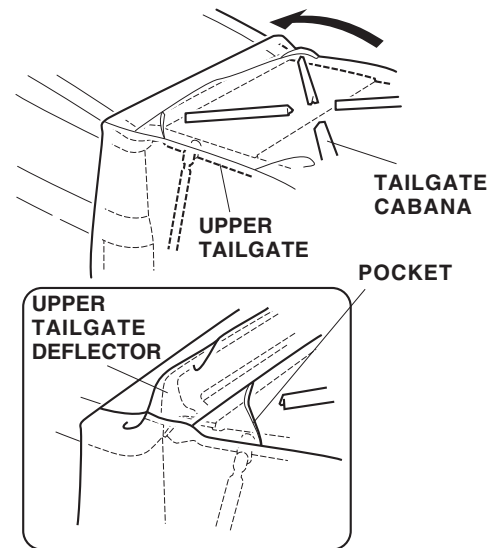

With upper tailgate deflector.

2. Open the tailgate, wrap the cabana straps inside and engage the buckle. Tighten the strap.

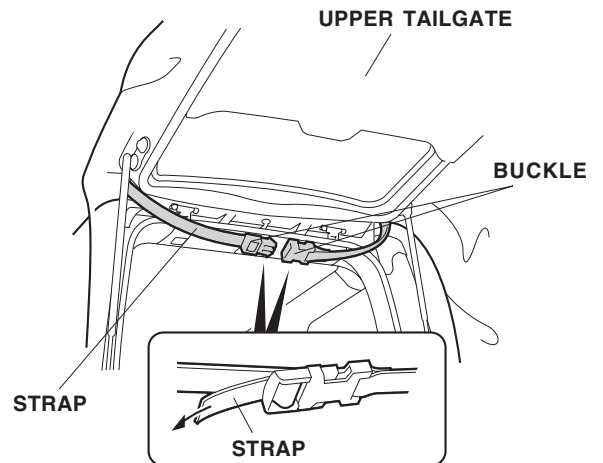

3. Assemble the two shock cord poles to make two long poles.

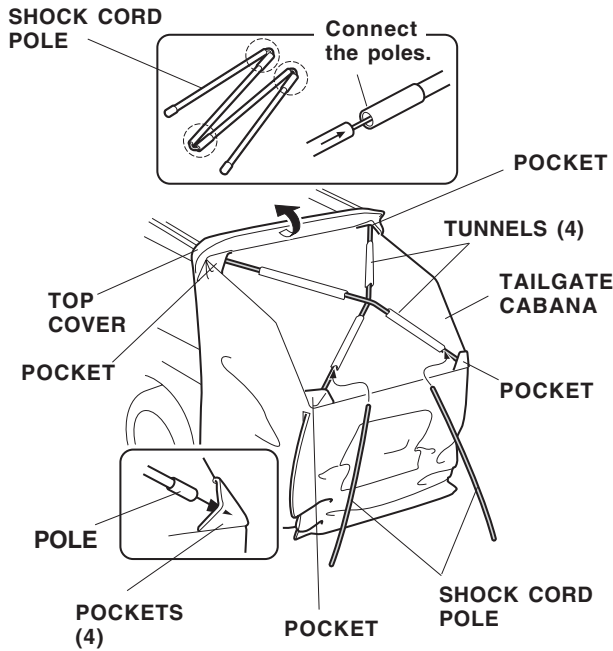

4. Lower the tailgate and insert the shock cord poles through the tunnels of the cabana. Place the end of each shock cord pole into the pockets of the cabana.
5. Place the top cover of the tailgate cabana forward over the roof.
6. Open the tailgate. Attach the corner hooks of the cabana to the rear fender flange.

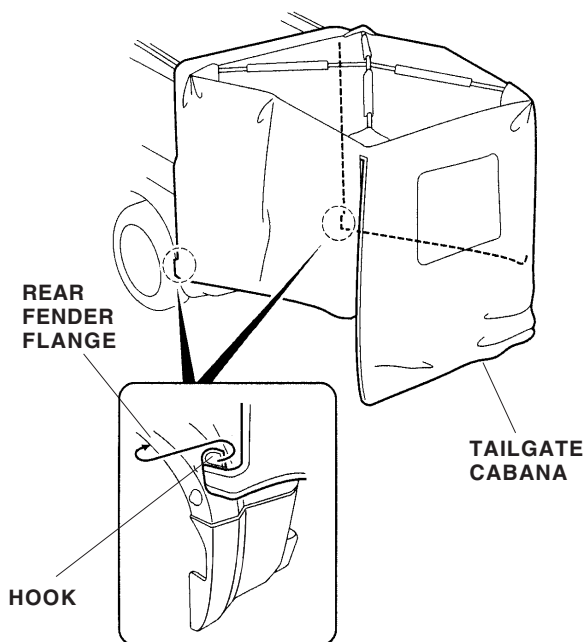

7. Lower the zippers to close the cabana.

NOTE: With an upper tailgate deflector installed, the zippers may not close the last 1 to 3 inches.

