



INSTALLATION INSTRUCTIONS

Accessory
**BICYCLE RACK
(INTERIOR)**
P/N 08L07-S9V-101A

Application
ELEMENT

Publications No.
All 24277
Issue Date
DEC 2002

Keep this information in the glove box for future reference.

PARTS LIST

Holder

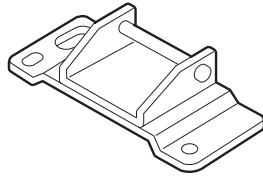

Bracket

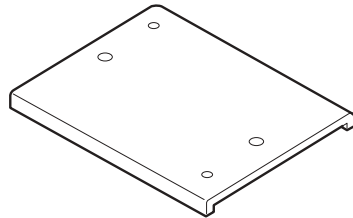

Quick shaft

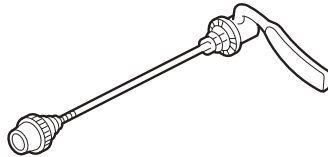

Belt

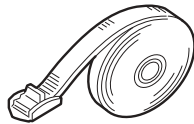

2 Velcro fasteners

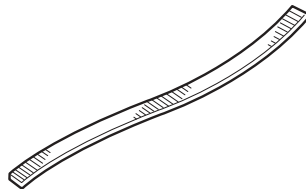

2 Long washer-bolts



2 Short washer-bolts



Owner's Manual

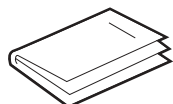

TOOLS AND SUPPLIES REQUIRED

12 mm Combination wrench

Drill

3 mm and 10 mm Drill bits

Eye protection (face shield, safety goggles, etc.)

INSTALLATION

Customer Information: The information in this installation instruction is intended for use only by skilled technicians who have the proper tools, equipment, and training to correctly and safely add equipment to your vehicle. These procedures should not be attempted by "do-it-yourselfers."

1. Open the hatch and the tailgate, and take out the cargo area floor (two hooks).

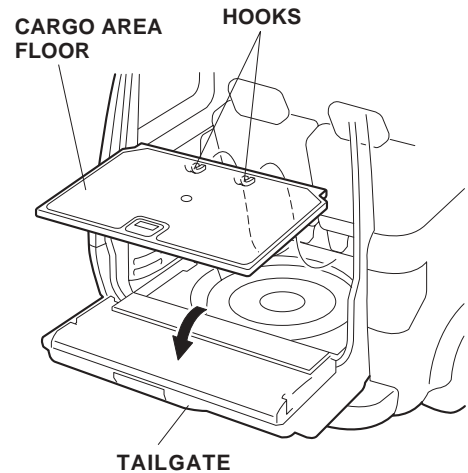

- Turn the cargo area floor over, and locate the four marks on the underside of the cargo area floor. When positioning one bicycle, mount the single bike to the rear position marks.

NOTE: If the vehicle is equipped with an armrest that contains a storage compartment, only one bike will fit. Position the holder to the rear set of marks.

- While wearing eye protection, drill a 3 mm hole and then finish with a 10 mm drill through the rear set of the marks.
- If installing a second bicycle attachment, drill a 3 mm hole and then finish with a 10 mm drill through other set of the marks.

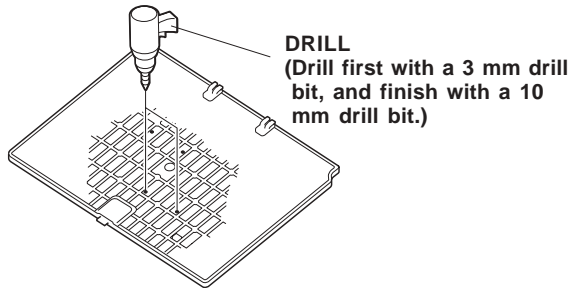
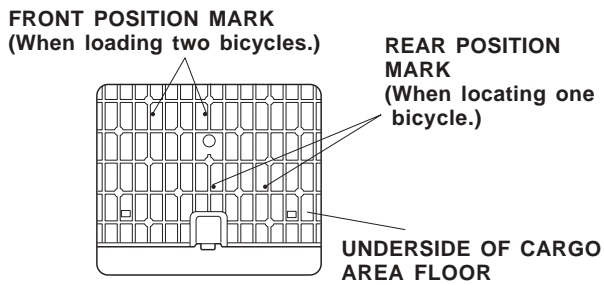

- Position the holder and bracket on the cargo lid, and install the two washers-bolts. Torque the bolts to 2 N·m (1.4 lbf-ft).

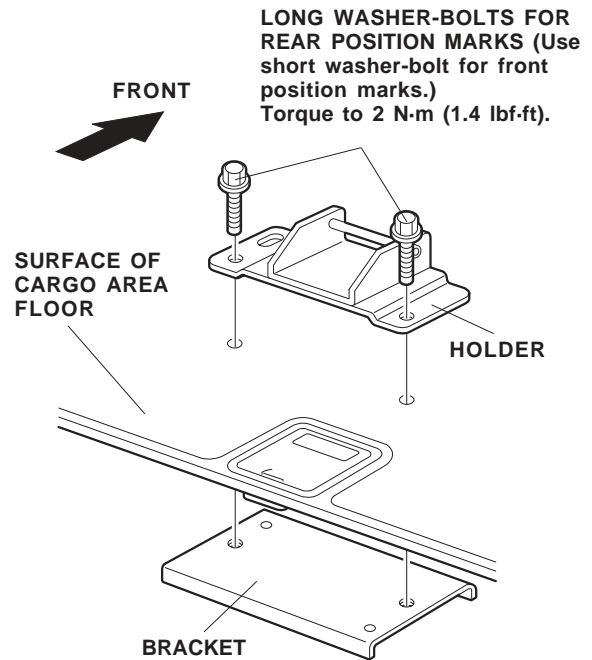

- To install the bicycle to the attachment, refer to the owner's manual supplied.