



INSTALLATION INSTRUCTIONS

Accessory

EXHAUST PIPE FINISHER
P/N 08F53-SLN-100

Application

FIT

Publications No.

All 31596

Issue Date

MAR 2006

PARTS LIST

Exhaust finisher

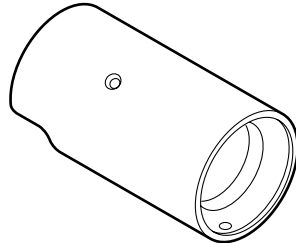

2 Flange bolts



TOOLS REQUIRED

10 mm Socket

Torque wrench

INSTALLATION

NOTE:

- Allow the exhaust pipe to cool down before you install the exhaust finisher kit.
- Never use abrasive-type cleaners to clean the exhaust finisher kit, as they may damage the finisher kit.

1. Partially thread the two flange bolts into the exhaust finisher.

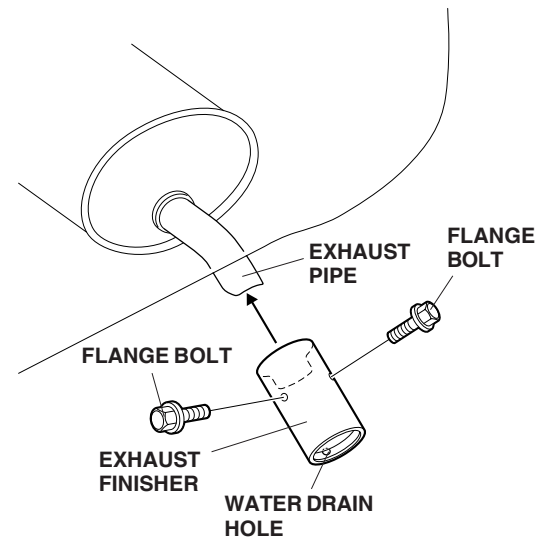

2. With the water drain hole facing down slide the exhaust finisher all the way onto the exhaust pipe.
3. Push the exhaust finisher firmly until it bottoms against the exhaust pipe, then torque the two flange bolts to 10 N·m (7 lb-ft.).

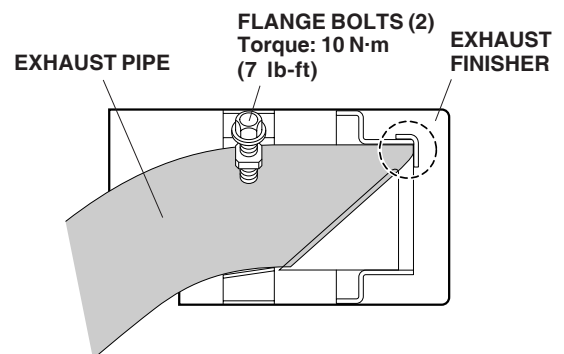

4. Start the engine, and rev it up a few times. Listen for vibration from the exhaust finisher, and adjust if necessary.