



INSTALLATION INSTRUCTIONS

Accessory	Application	Publications No.
SUBWOOFER	ODYSSEY	All 24141
		Issue Date JAN 2003

NOTE: You cannot install the subwoofer in a vehicle equipped with an under seat Navigation Unit and an under seat CD Changer.

PARTS LIST

Subwoofer Kit:
P/N 08A39-5E1-010

Subwoofer

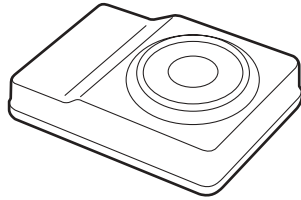

Owner's Manual

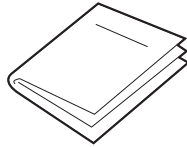

Subwoofer Attachment Kit:
P/N 08B39-S0X-100A

Subwoofer bracket

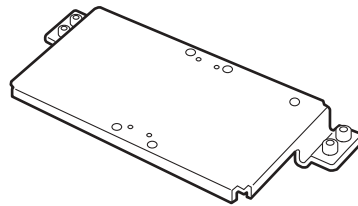

Subwoofer harness

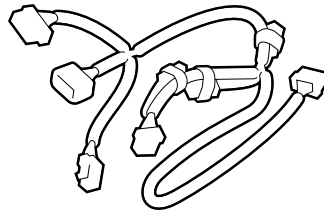

3 Cushions

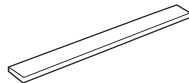

Subwoofer switch

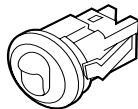

4 flange bolts, 6 x 12 mm



2 Cushion tapes

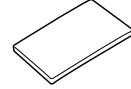

EPT sealer

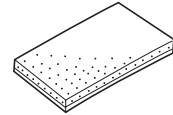

8 Wire ties

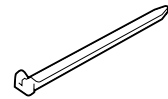

Fuse seal

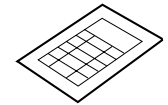

TOOLS AND SUPPLIES REQUIRED

#2 Phillips screwdriver

Flat-tip screwdriver

Stubby Phillips screwdriver

8 mm, 10 mm, and 14 mm Combination wrenches

8 mm, 10 mm, and 14 mm Sockets

Awl

Drill

3 mm drill bit

20 mm Hole saw

Isopropyl alcohol

Tape measure

Center punch

Ratchet

Torque wrench

Shop towel

Diagonal cutters

Utility knife

Wire ties

Illustration of the Subwoofer Installed on the Vehicle

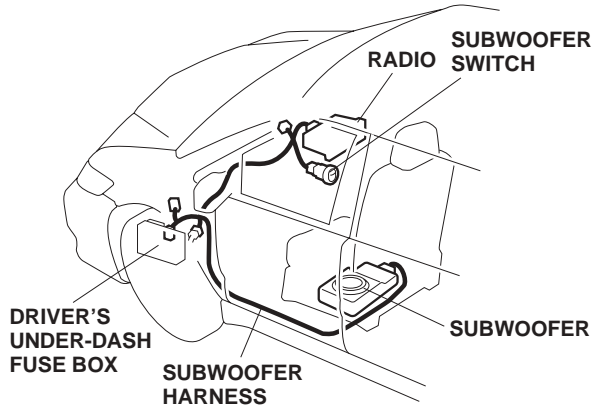

INSTALLATION

Customer Information: The information in this accessory installation instruction is intended for use only by skilled technicians who have the proper tools, equipment, and training to correctly and safely add equipment to your vehicle. These procedures should not be attempted by "do-it-yourselfers."

NOTE: LX and EX models without navigation: If equipped with the optional CD changer under the driver's seat, the CD changer must be relocated under the passenger's seat, in place of the front passenger's under seat storage tray.

1. Make sure you have the anti-theft code for the radio, then write down the frequencies for the preset buttons.
2. Turn the ignition key to the on position, press the brake pedal, and move the gear selector to the "1" position.
3. Disconnect the negative cable from the battery.

4. Remove the console panel:
 - Starting from the left side, gently pull along the bottom to release the lower clips, and work toward the top to release all ten clips.
 - Pull out the console panel, unplug the vehicle connectors, and remove the panel.

Without Navigation System:

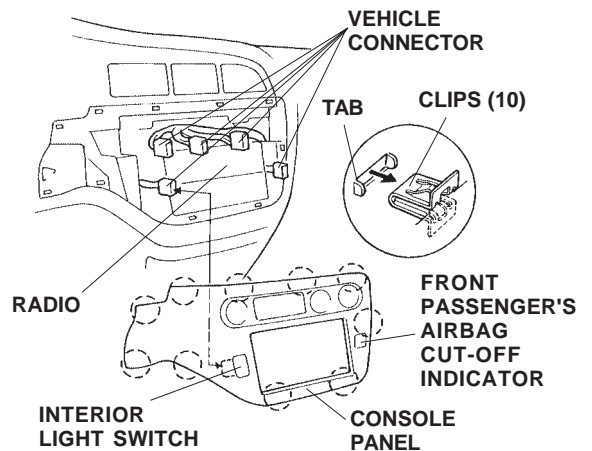

With Navigation System:

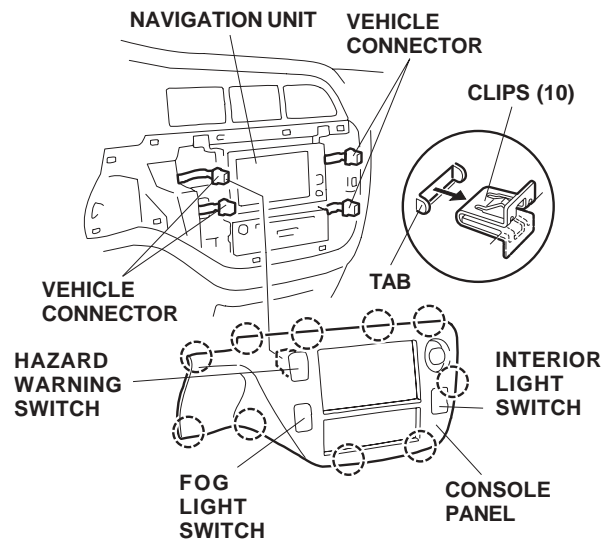

- Remove the radio or navigation unit. (Remove the bolts and screws. Unplug the connectors and the antenna lead.)

Without Navigation System:

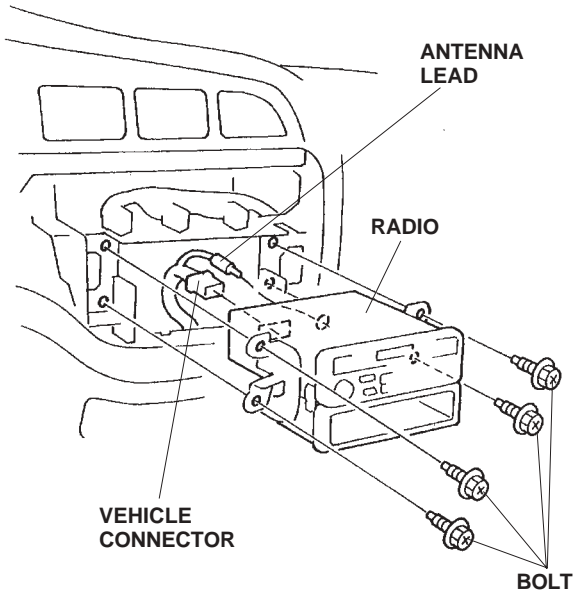

With Navigation System:

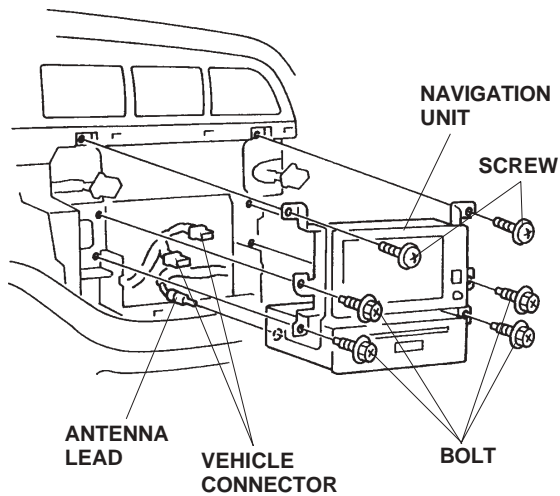

- Remove the fuel lid opener knob.
- Pry up on the clips, and remove the driver's door sill trim. Be careful not to damage the clips.

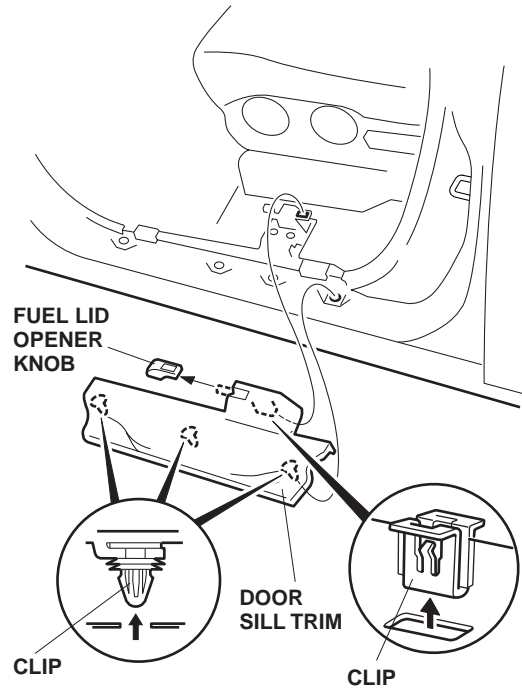

- Pull up the door weatherstrip, and unscrew the plastic screw securing the kick panel. Remove the kick panel by pulling it out toward you.

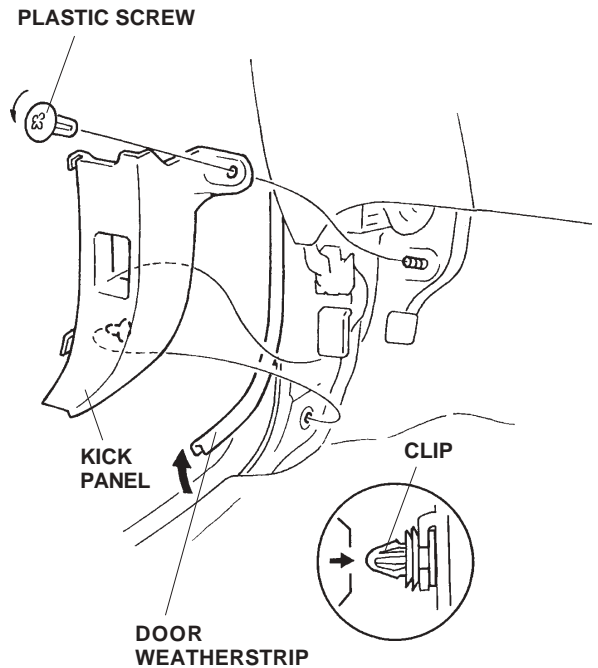

- Remove the driver's dashboard lower cover (one self-tapping screw and three clips). On EX model, unplug the in-car temperature sensor, and disconnect the air hose.

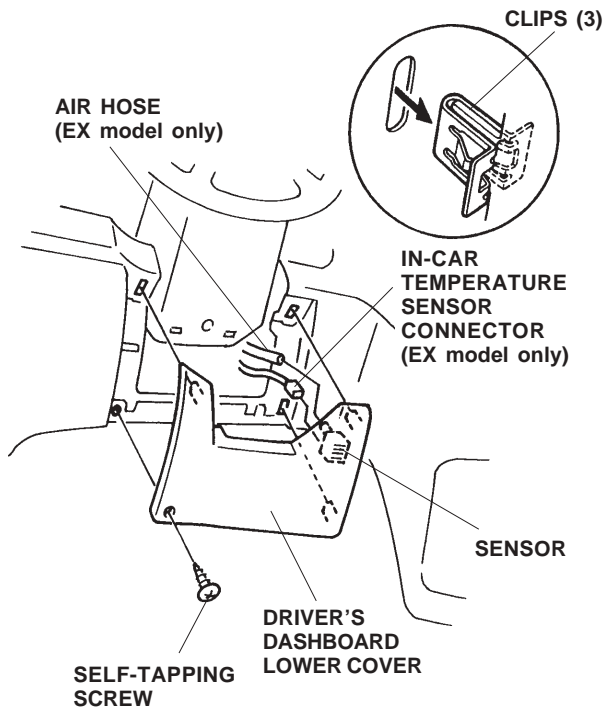

- Remove the driver's seat inside seat rail covers.

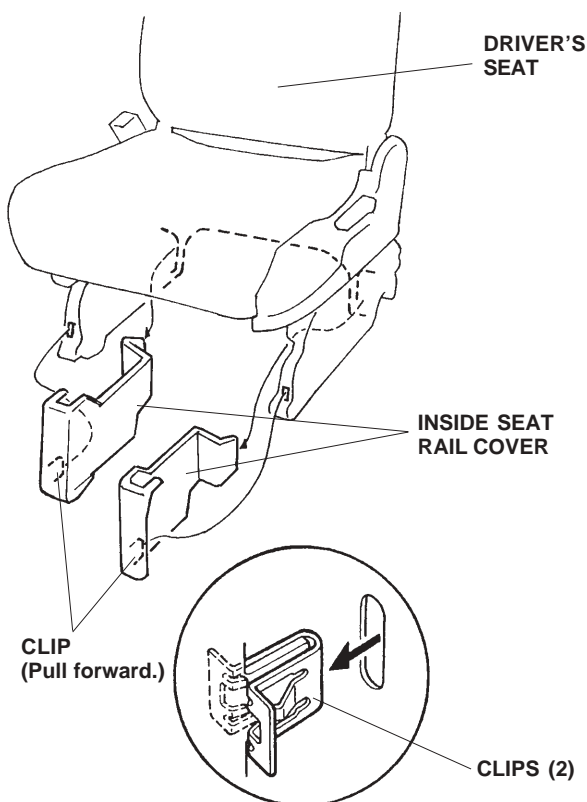

- Slide the driver's seat fully forward, and remove the rear seat rail cover from the driver's seat by pulling to release the three clips. Connect the battery if necessary to do this step, then disconnect the battery.

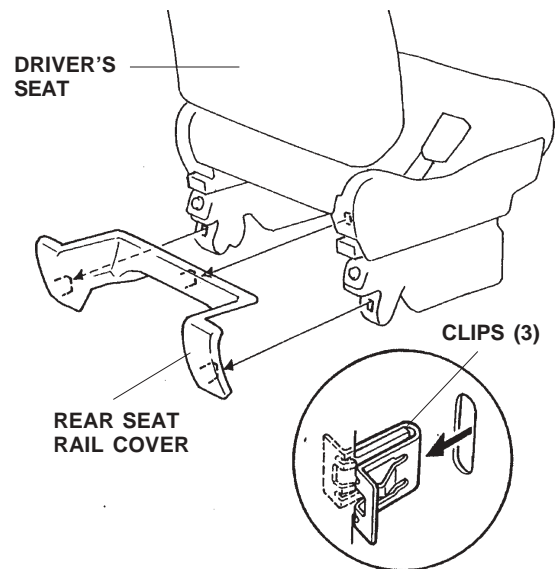

NOTE: If the vehicle is equipped with the optional CD Changer under the driver's seat, continue with Step 12. It will be necessary to move the CD Changer under the passenger's seat.

If the vehicle is not equipped with the optional CD Changer, go to Step 34.

Removal of the CD Changer Attachment - Driver's Seat

- Remove the four bolts that secure the driver's seat so that the seat can be tilted back. Take care not to damage the vehicle harness when lifting the driver's seat up. Disconnect the harness connectors.

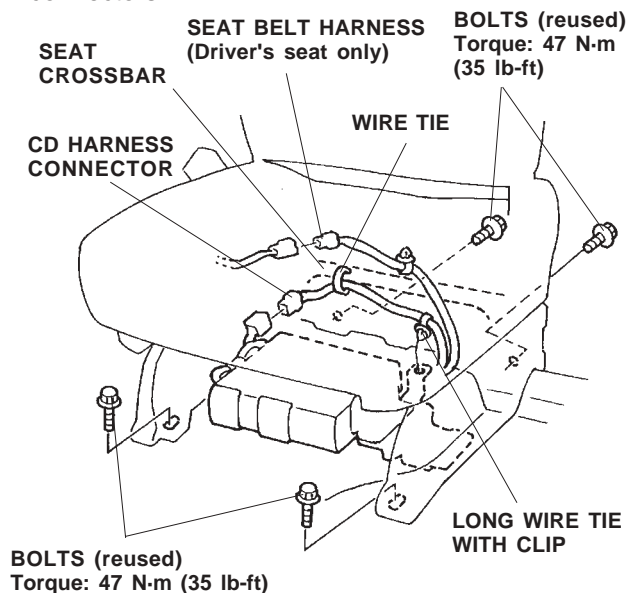

13. Remove the four 6 mm flange nuts, and remove the CD Changer.

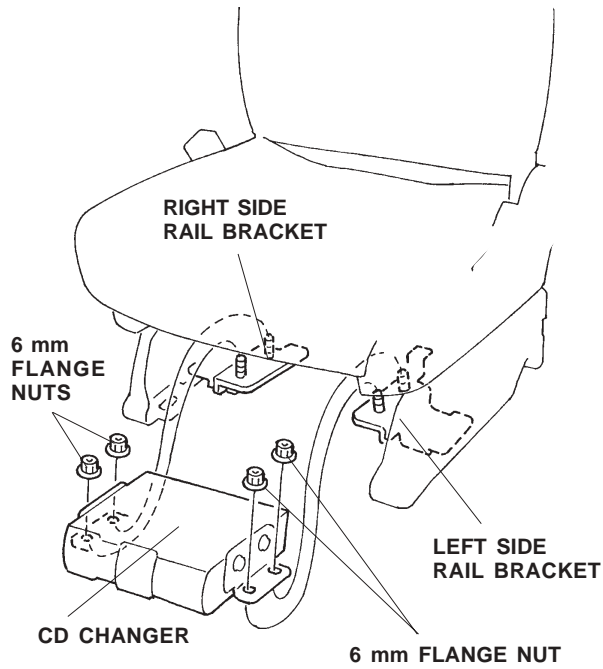

14. Remove the four 6 mm flange bolts, and remove the side rail brackets.

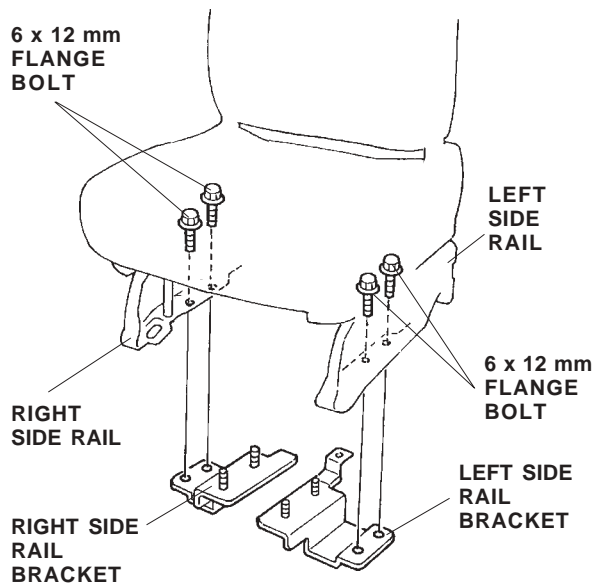

15. Remove the necessary wire ties and cushion tape, and remove the CD Changer wire harness from under the driver's seat.

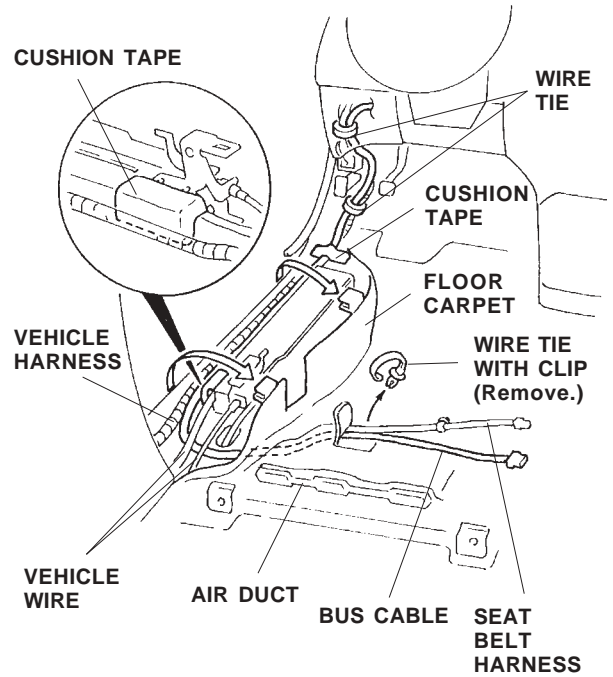

16. Remove the necessary wire ties and clip, and remove the CD Changer wire harness from the dash.

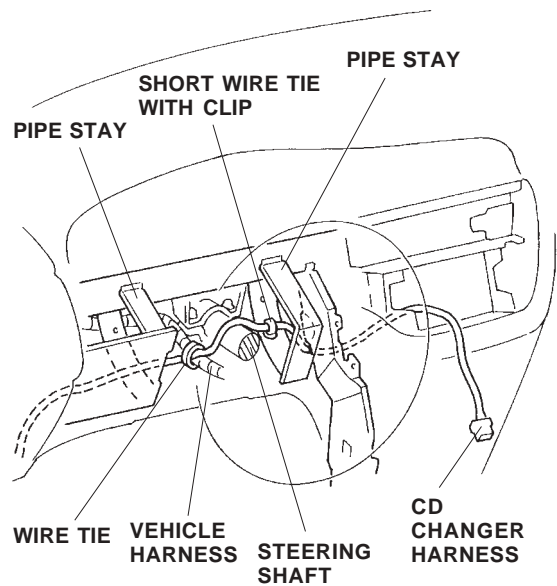

Installing the CD Changer Attachment - Passenger's Seat

17. Pry up on the clips, and remove the passenger's front door sill trim. Be careful not to damage the clips.

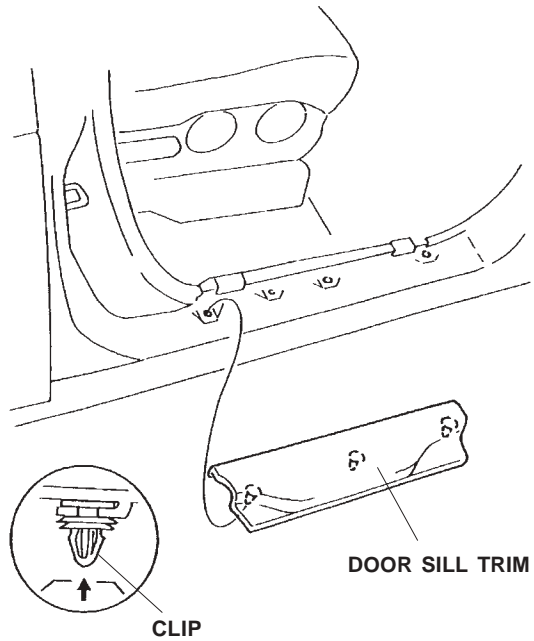

18. Pull up the door opening trim, and remove the plastic screw securing the front passenger's kick panel. Remove the kick panel by pulling it out toward you.

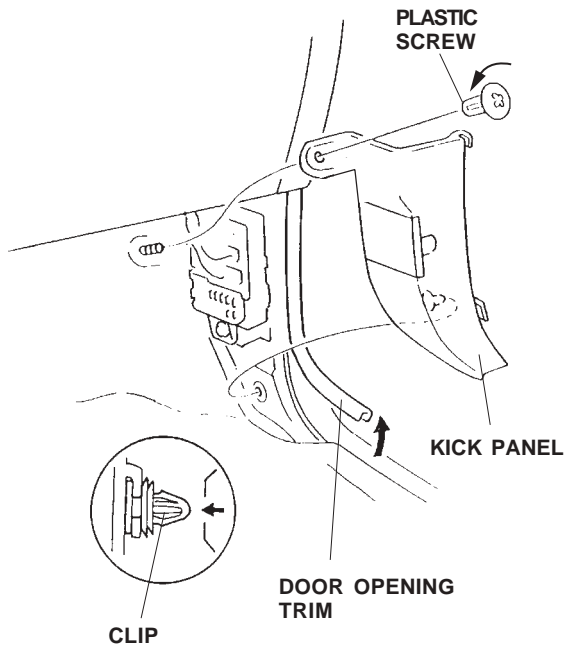

19. Remove the right and left glove box stops, then lower the glove box all the way down, and let it hang by the hinges.

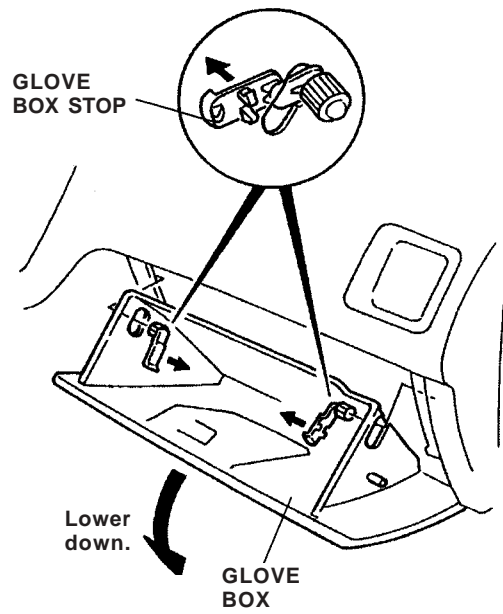

20. Remove the passenger's seat inside rail covers.

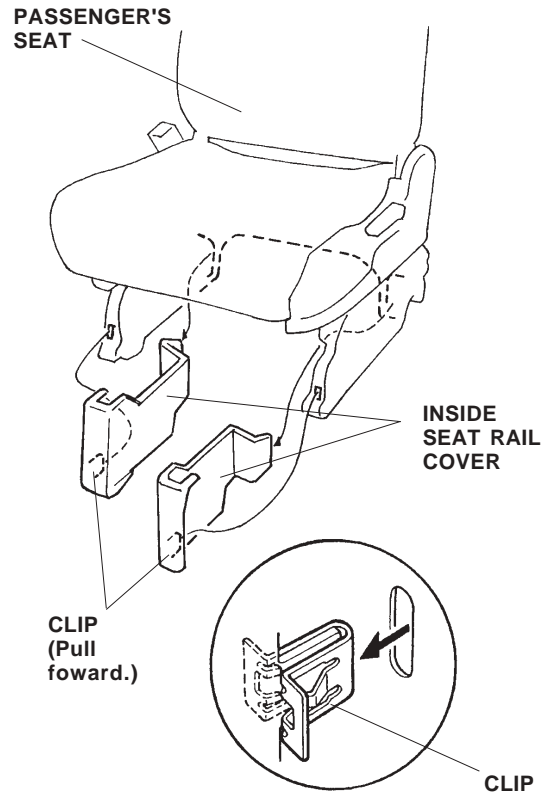

- Remove the rear seat rail cover from the passenger's seat by pulling to release the three clips.

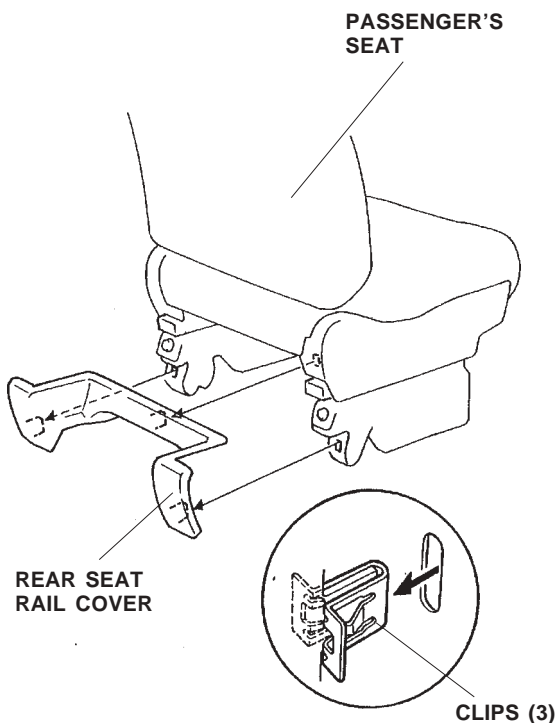

- Remove the four bolts that secure the passenger's seat side rails to the floor.

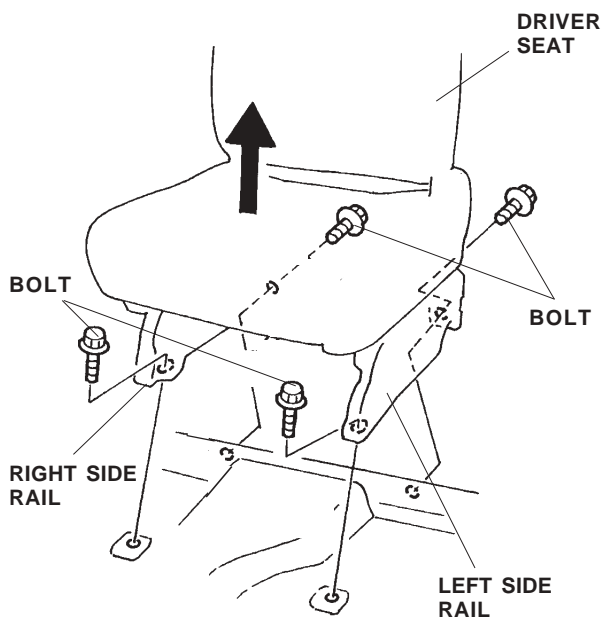

- If equipped, remove the under seat storage tray and the under seat storage tray bracket from the passenger's seat (two self-tapping screws). Set the storage tray aside; it will not be reused.

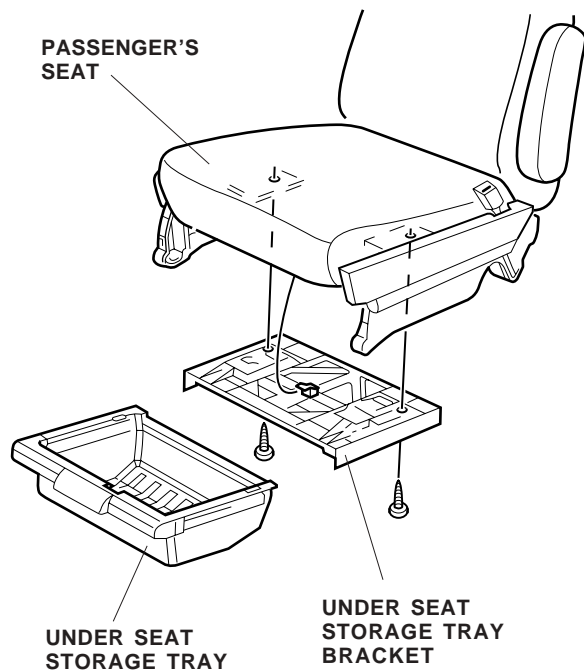

Installing the Seat Rail Brackets - Passenger's Seat

- Position the left seat rail bracket on the passenger's seat left side rail, and align the two holes in the bracket with the two holes in the side rail. Attach the bracket with two 6 x 12 mm flange bolts. Repeat to install the right side rail bracket.

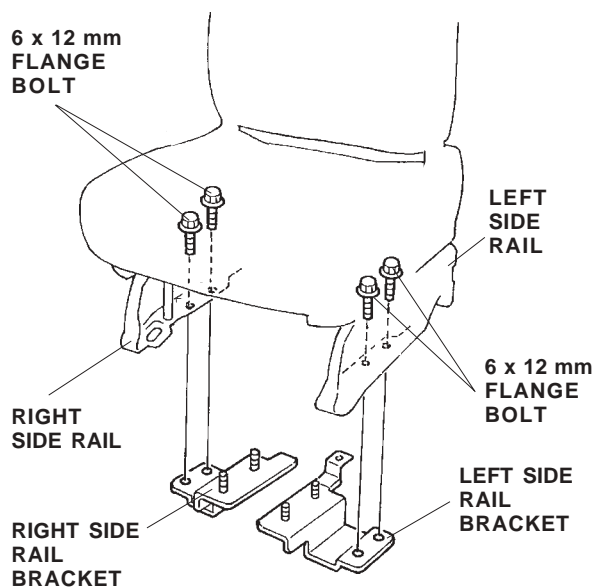

Routing the CD Changer Harness - Passenger's Seat

25. Turn over the floor carpet. Route one end of the CD Changer harness under the carpet and floor heater duct toward the cutout opening in the carpet.

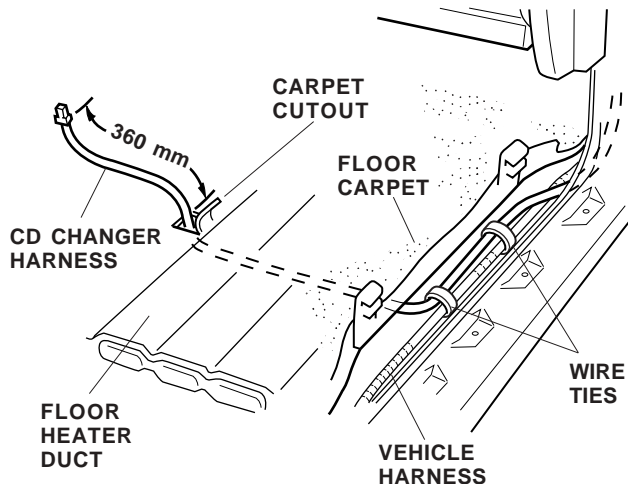

26. Pull the harness out through the carpet opening about 360 mm from the cutout.
27. Route the other end of the harness along the passenger's door sill area. Secure the CD harness to the vehicle harness with two wire ties in the areas shown.

28. Route the CD Changer harness up the kick panel area, along the glove box frame and over to the audio unit opening.

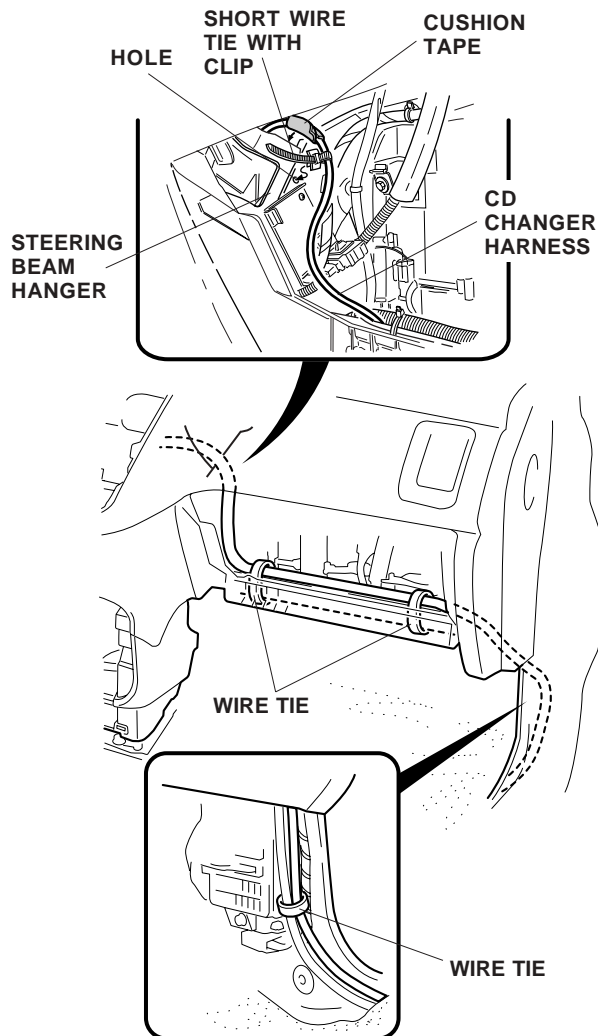

29. Attach the short wire tie with clip to the hole in the steering beam hanger, and secure the CD Changer harness with this wire tie. Wrap one cushion tape around the harness above the wire tie to protect it from the edge of the steering beam hanger.
30. Secure the harness to the glove box frame with three wire ties in the areas shown.

- Route the CD Changer harness over the center dashboard stay and out through the audio opening. The cable should be the same length as the audio unit connector.

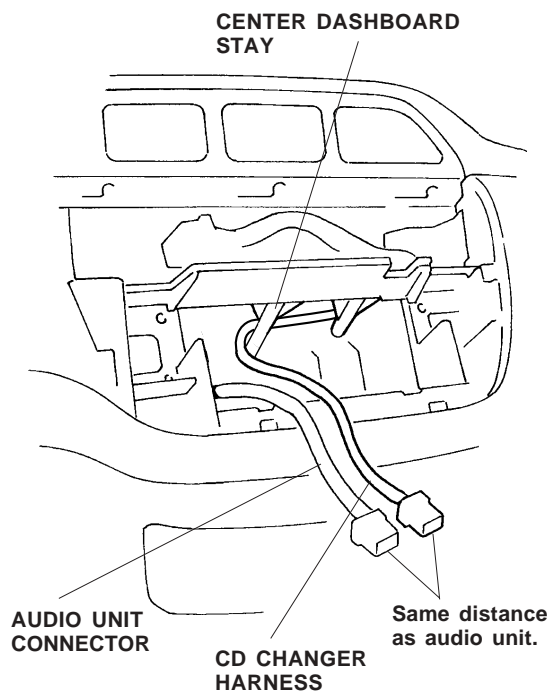

- Place the CD changer on the side rail brackets, and install the four 6 mm flange nuts. Tighten the nuts securely.

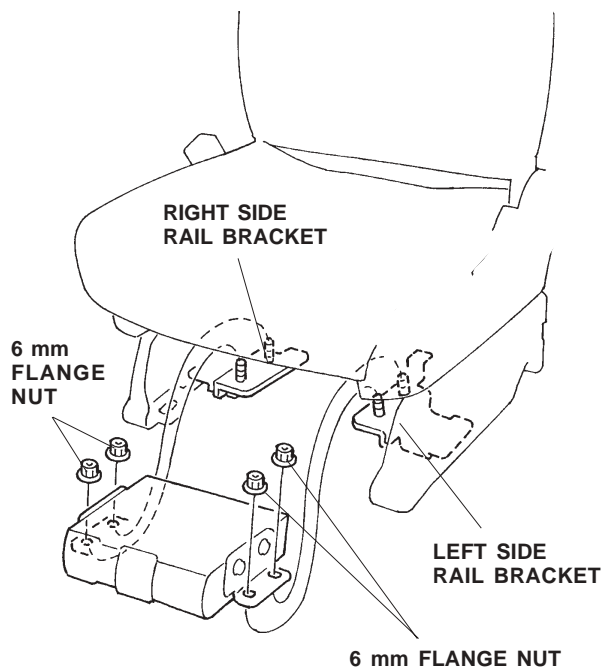

- Reinstall the passenger's seat and torque the four seat mounting bolts to 47 N-m (35 lb-ft).

Installing the Subwoofer - Driver's Seat

- Remove the four bolts that secure the driver's seat so that the seat can be tilted back. Take care not to damage the vehicle harness when tilting the driver's seat back.

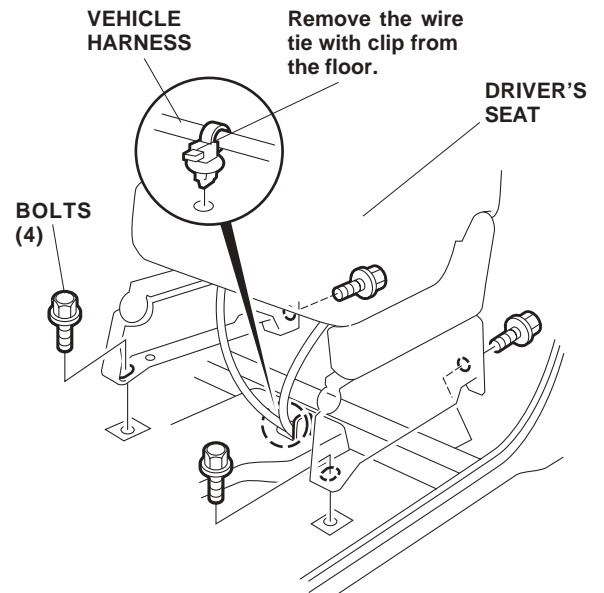

- Remove the wire tie with clip from the floor as shown. Do not remove the wire tie from the harness at this time.
- Using a utility knife, make three 40 mm slits in the floor carpet as shown. Use care not to damage the wire harnesses concealed under the floor carpet. The existing flap and the new cutout become one large opening.

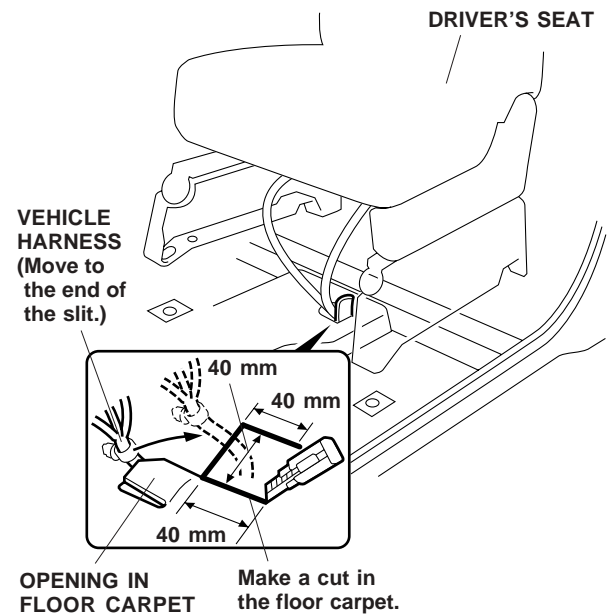

- Reposition the two vehicle harnesses rearward through to the end of the new slit you made.

Routing the Subwoofer Harness

38. Turn over the floor carpet. Route the subwoofer harness under the floor carpet and pull the subwoofer harness 8-pin connector out through the slit in the floor carpet you made in step 35.
39. Adjust the length of the subwoofer harness so that the distance from the slit in the floor carpet to the tip of the subwoofer harness 8-pin connector is 650 mm.

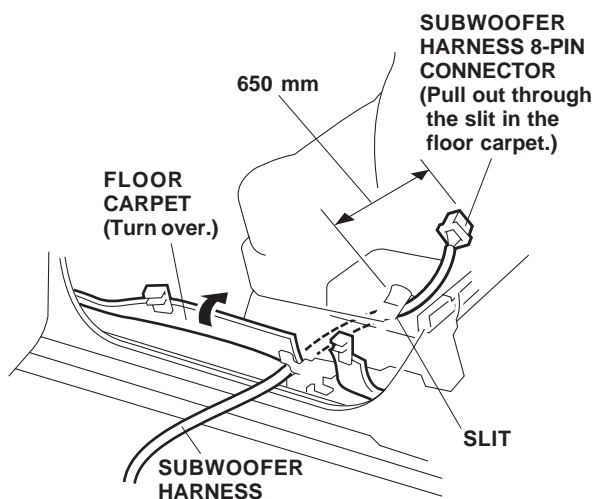

40. Route the other end of the subwoofer harness forward toward the dashboard along the vehicle harness.
41. Using isopropyl alcohol on a shop towel, thoroughly clean the areas where the cushion tapes will attach. Secure the subwoofer harness to the floor panel with two cushion tapes in the areas shown.

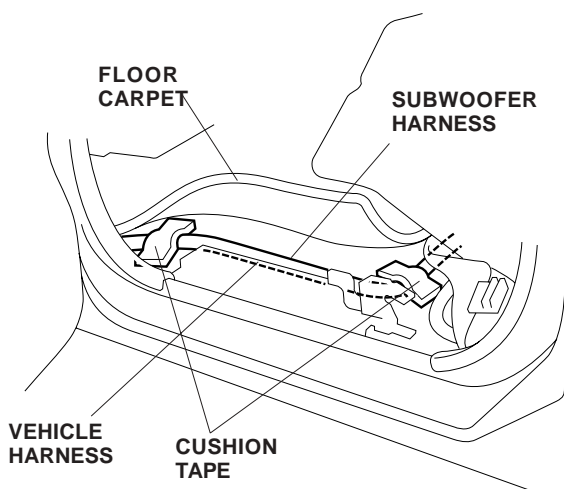

42. Route the subwoofer harness up to the driver's under-dash fuse/relay box.
43. Secure the subwoofer harness to the vehicle harness with three wire ties in the areas shown.

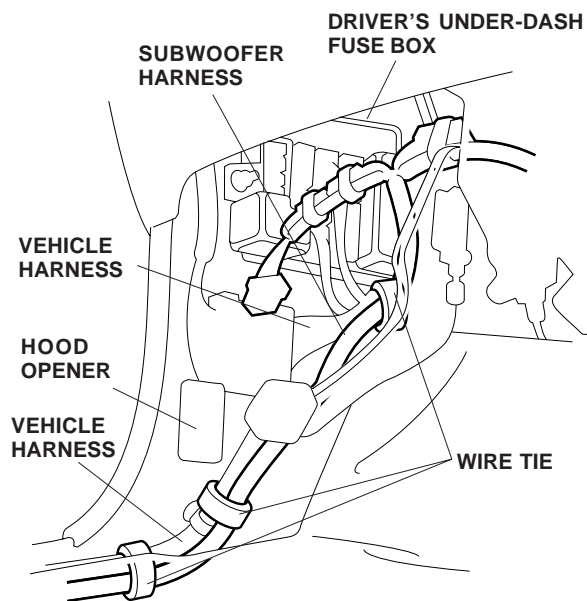

44. Attach the fuse seal ("OPTION 7.5A") to the fuse holder on the subwoofer harness, and plug the subwoofer harness 6-pin connector into the appropriate socket of the driver's under-dash fuse box as shown.

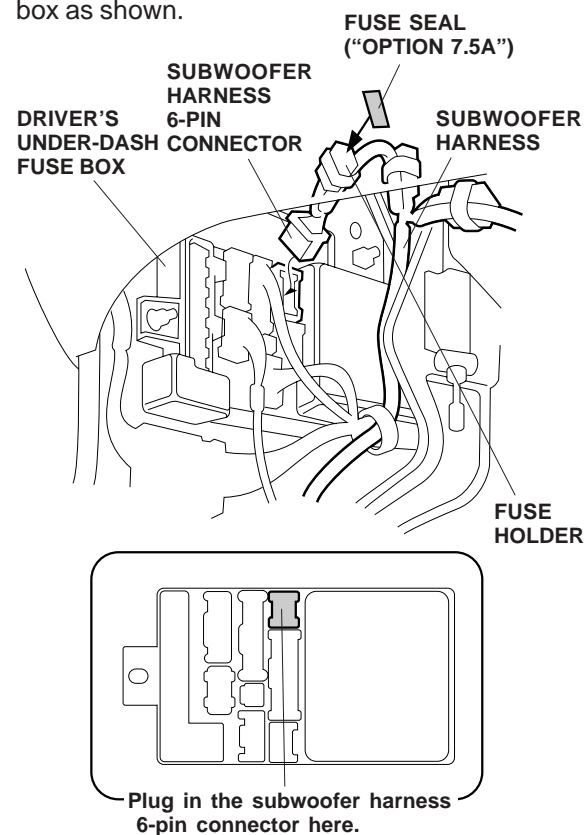

- If another harness 6-pin connector is already plugged into the driver's under-dash fuse box socket, unplug that connector and plug it into the optional 6-pin connector taped to the harness.

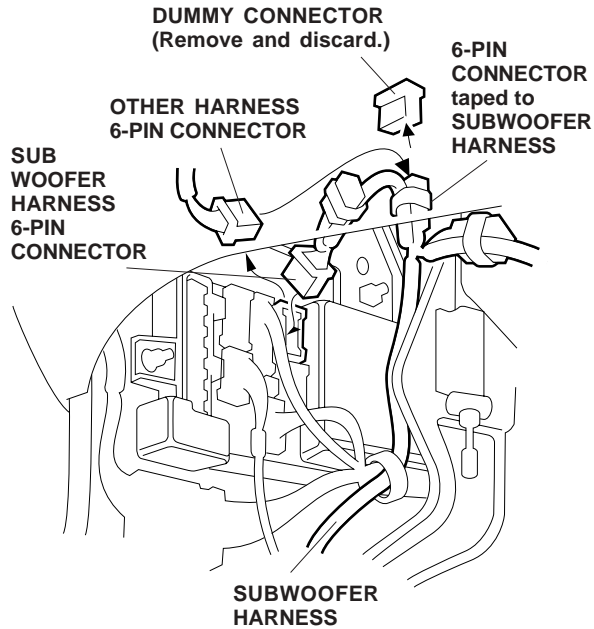

- Secure the subwoofer harness to the vehicle harness with a wire tie.

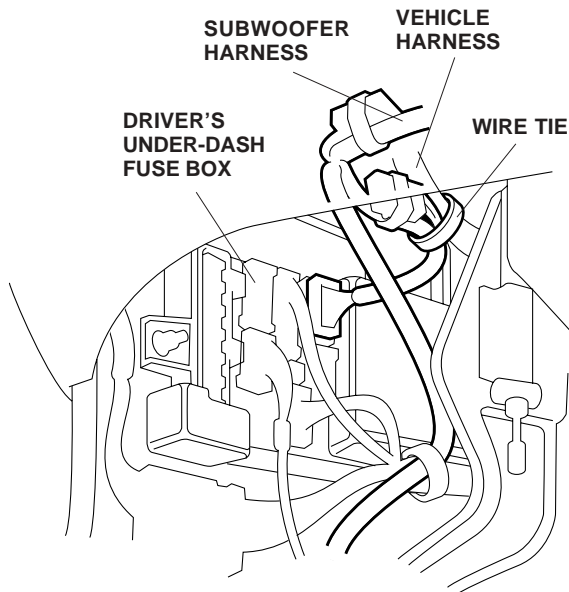

- Route the subwoofer harness above the steering column and toward the center console panel opening. Secure the harness to the vehicle harness with two wire ties. Do not attach the subwoofer harness to the SRS harness.

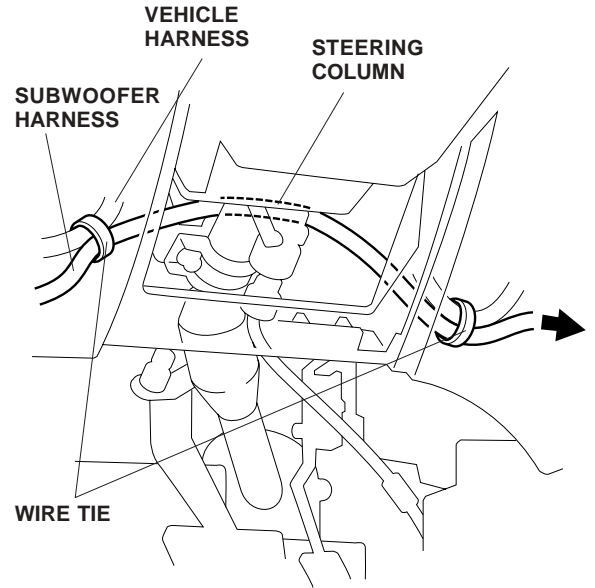

48. Route the subwoofer harness and connectors over the in-car temperature sensor air hose (transparent corrugated tube) and out through the center console panel opening .

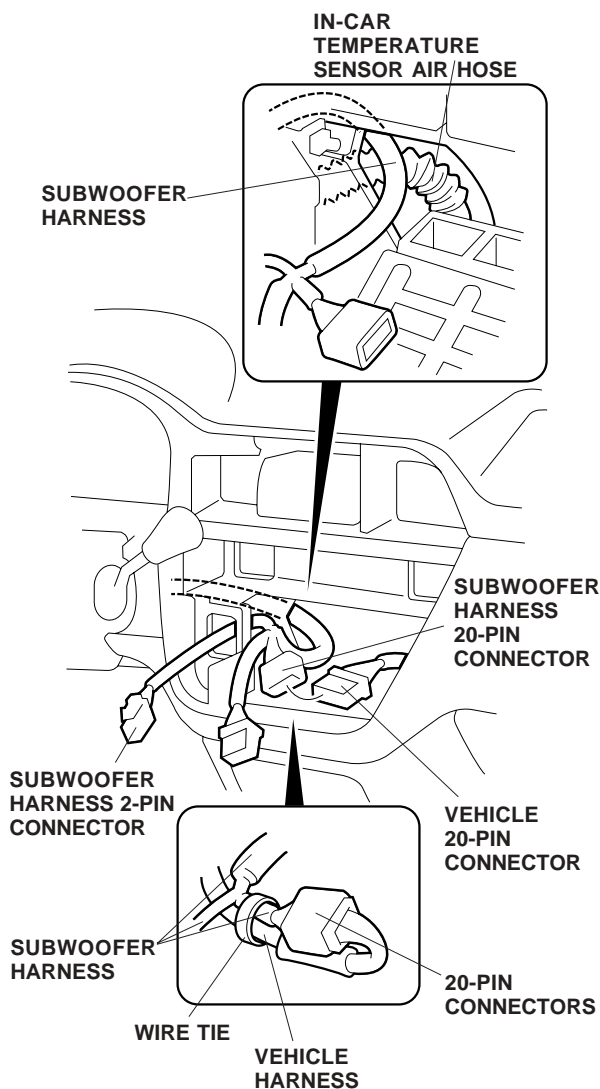

49. Route the subwoofer harness 2-pin connector out through the small switch opening as shown:
- Connect the subwoofer harness 20-pin connector to the vehicle 20-pin connector.
 - Secure the subwoofer harness to the vehicle harness with the wire tie.
 - Bundle the excess harness under the dash and secure it using one wire tie.

Installing the Subwoofer Bracket

50. Get the subwoofer and bracket. Remove and save the four screws from the bottom of the subwoofer.

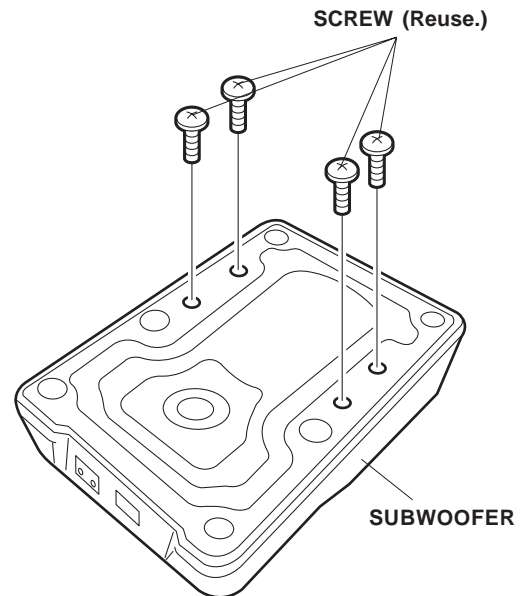

51. Using isopropyl alcohol, thoroughly clean the areas where the cushions will attach. Attach the three cushions to the subwoofer in the areas shown.

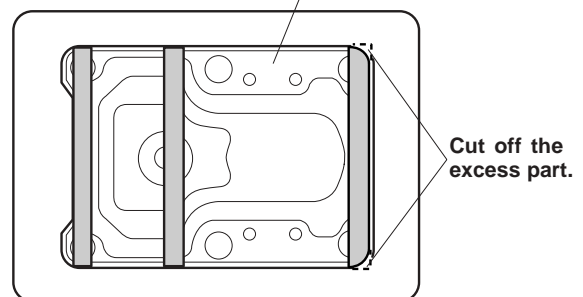
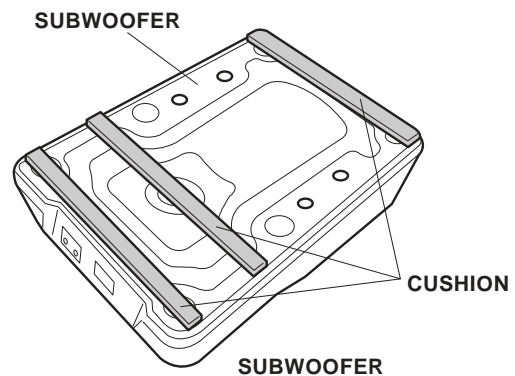

52. Position the subwoofer on the subwoofer bracket, and reinstall the four screws you removed.

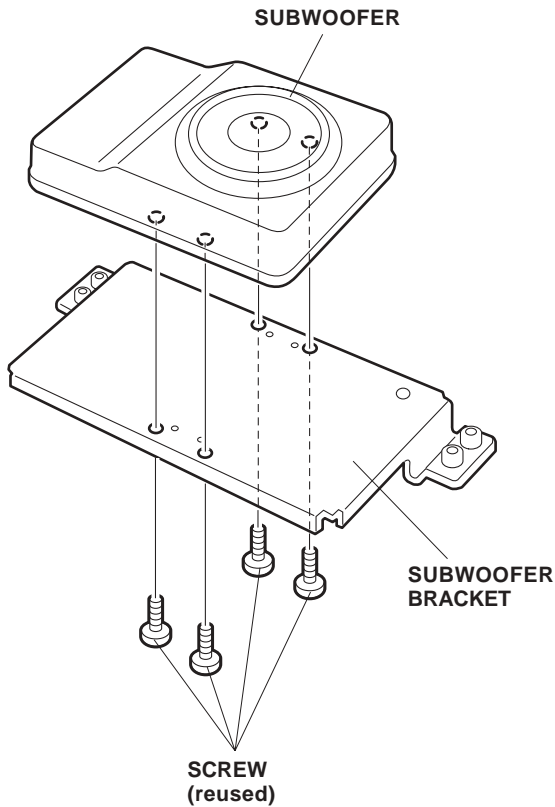

53. Attach the subwoofer assembly on top of the seat bracket with the four 6 x 12 mm flange bolts from the attachment kit.

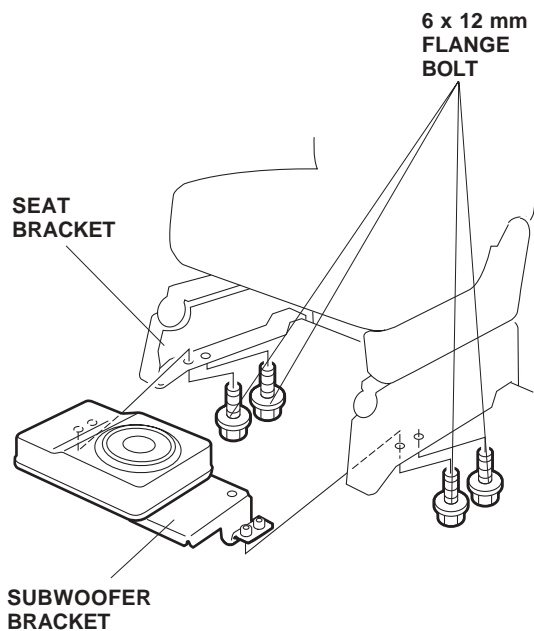

54. Connect the subwoofer harness:

Power Seat Equipped Model:

- Wrap the EPT sealer around the subwoofer harness.
- Connect the 8-pin connector of the subwoofer harness to the subwoofer.
- Locate the wire tie with clip removed in step 12, and attach the new wire tie with clip about 10 mm in front of the existing clip. Push the new clip into the hole in the subwoofer bracket to secure the vehicle harness.
- Cut the wire tie with clip removed in step 12 being careful not to damage the vehicle harness.
- Reinstall the seat with the four seat bolts, and torque the bolts to 47 N·m (35 lb-ft).
- Slide the seat back and forth to verify that the wire harnesses are not pinched or stretched.

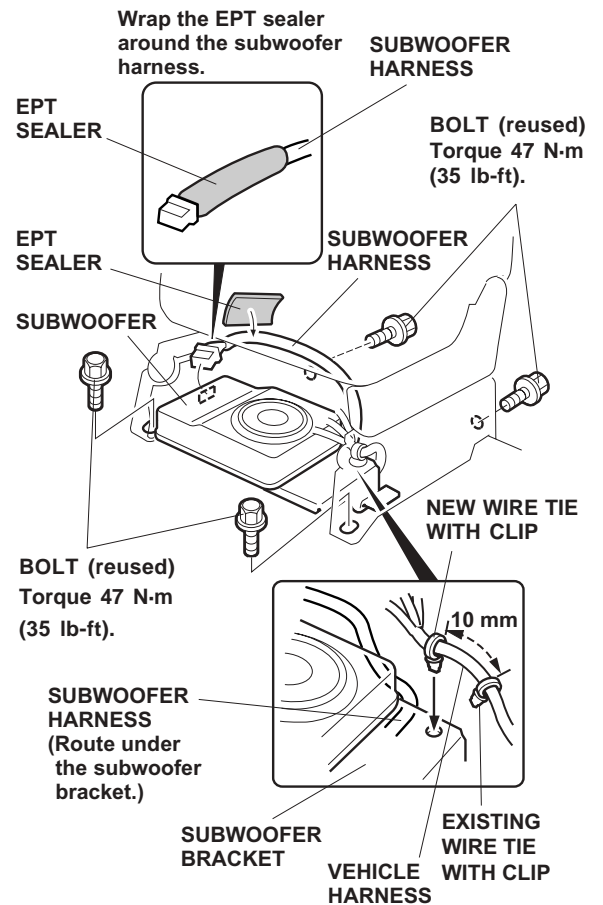

NonPower Seat Equipped Model:

- Wrap the EPT sealer around the subwoofer harness.
- Connect the 8-pin connector of the subwoofer harness to the subwoofer.
- Cut the wire tie with clip removed in step 12 being careful not to damage the vehicle harness.
- Secure the vehicle harness to the vehicle pipe with one wire tie.
- Reinstall the seat with the four seat bolts, and torque the bolts to 47 N·m (35 lb-ft).
- Slide the seat back and forth to verify that the wire harnesses are not pinched or stretched.

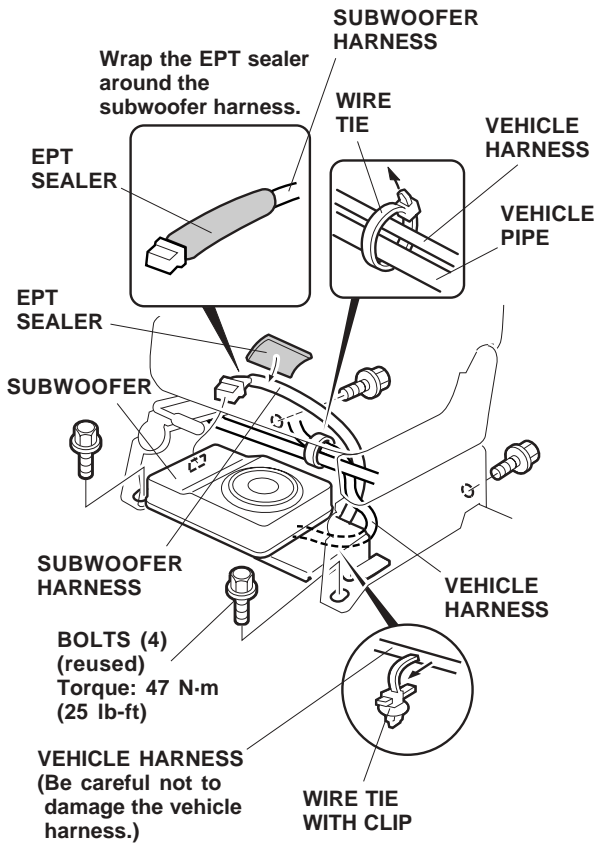

Installing the Subwoofer Switch

55. Using a measuring tape and an awl, mark the console panel as shown. Lightly punch the mark with a center punch.

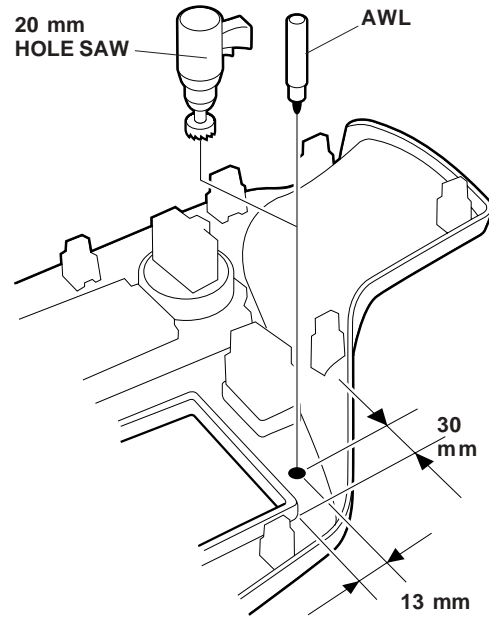

56. While wearing eye protection, drill a 20 mm hole through the center-punched mark:
 - First drill a pilot hole with a 3 mm drill bit, then finish with a 20 mm hole saw.
 - Remove all burrs.
57. Install the subwoofer switch in the hole you just drilled in the console panel.

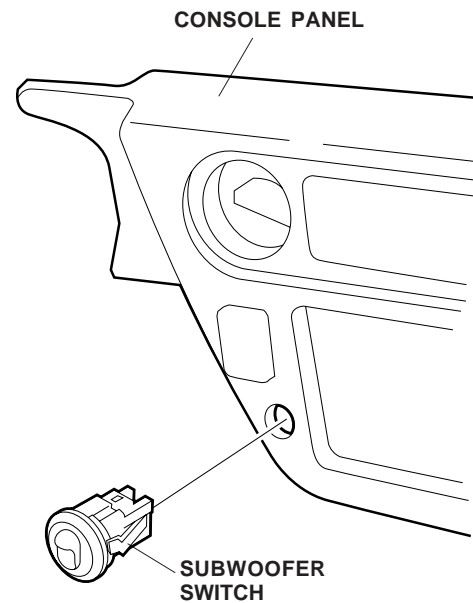

58. Connect the subwoofer harness connector and the antenna lead into the rear of the radio or navigation unit, then slide it into the console panel opening. Tighten the bolts or screws securely.

Without Navigation System:

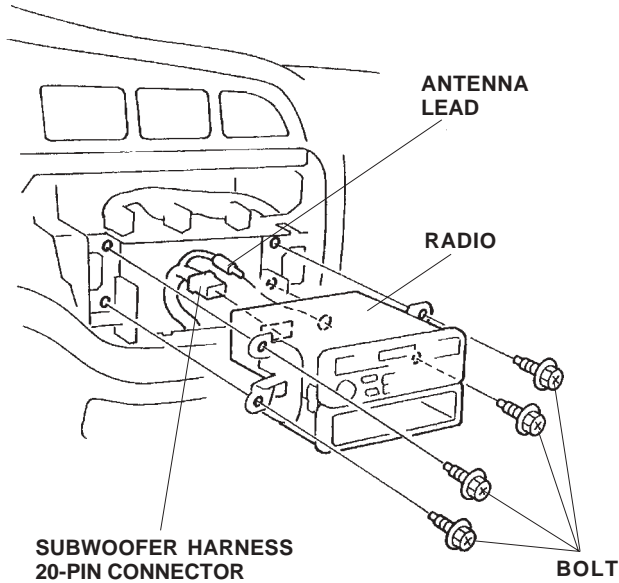

With Navigation System:

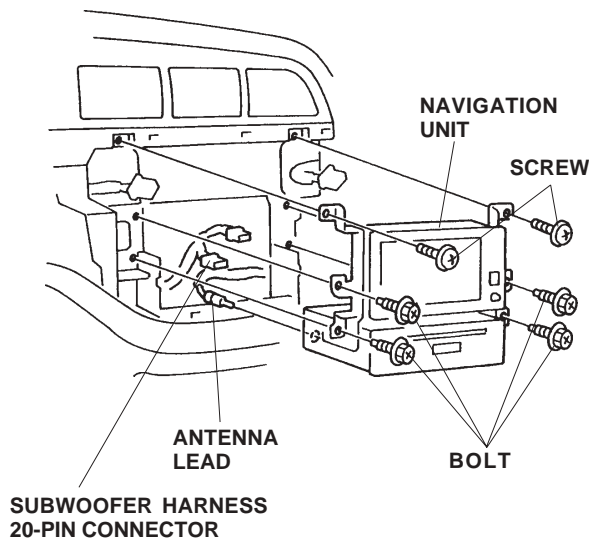

59. Hold the console panel near the console opening, and connect the subwoofer harness 2-pin connector to the subwoofer switch.
60. Connect the vehicle connectors to the console panel, and reinstall the console panel.

Without Navigation System:

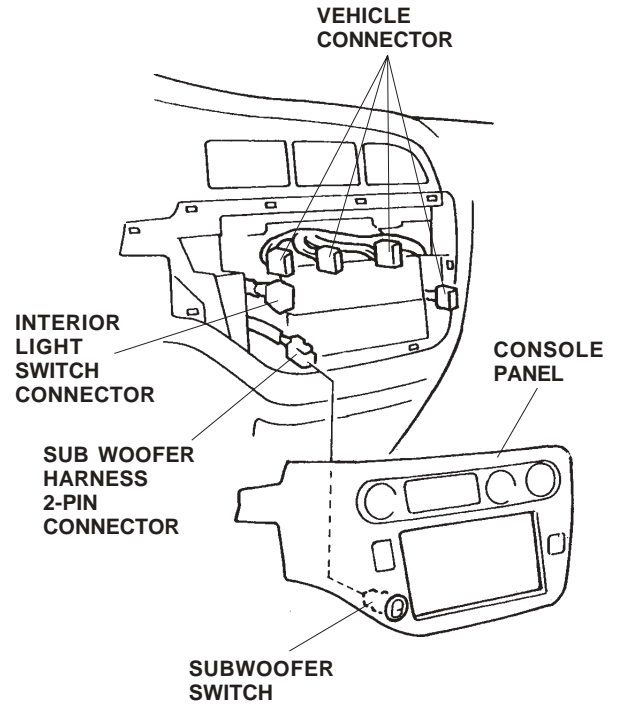

With Navigation System:

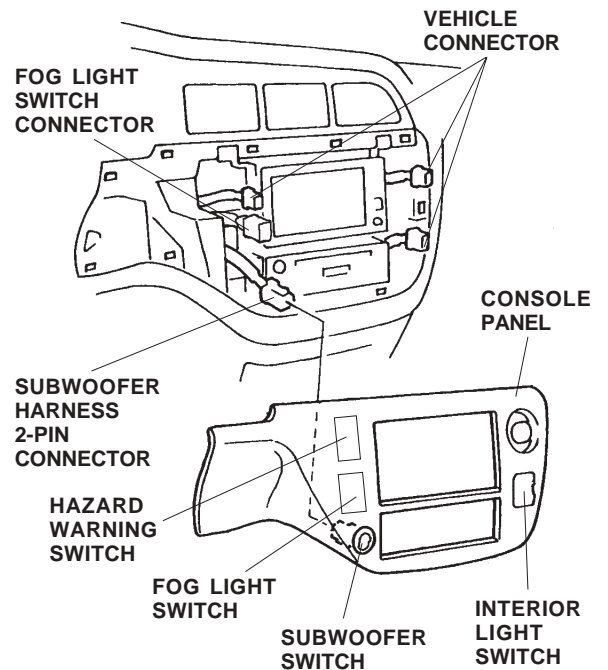

61. Check that all wire harnesses and cables are routed properly and all connectors are plugged in.
62. Reconnect the negative cable to the battery.
63. Enter the customer's radio anti-theft code and reset the radio station presets.
64. Reset the clock.
65. Check the operation of the Subwoofer according to the Owner's Manual supplied with the unit.
66. Reinstall all removed parts.

NOTE: Whenever the battery is disconnected, the driver's window AUTO function is disabled.

67. Start the engine. Push down on the driver's window switch until the window is fully open.
68. Pull up on the driver's window switch to close the window completely, then hold the switch for 2 seconds.
69. Test the AUTO window function.
70. Do the PCM idle learn procedure.
 - Make sure all electrical items are turned off.
 - Start the engine . Hold the engine speed at 3,000 rpm with no load (in Park or Neutral) until the radiator fan comes on.
 - Let the engine idle for about 5 minutes with the throttle fully closed and with all electrical items off.

NOTE: If the radiator fan comes on during this step, the time it is operating must not be included in the 5 minutes.

To replace the fuse: Open the lid of the fuse holder taped to the subwoofer harness, remove the old fuse, and install a new 7.5A fuse.

