

2003 ODYSSEY - Dust and Pollen Filter Replacement

The dust and pollen filter should be replaced every 30,000 miles (48,000 km) or 24 months whichever comes first. Replace the filter more often if the airflow is less than usual.

1. Remove the glove box.
2. Cut the plastic cross brace in the glove box opening with diagonal cutters in the area shown, and discard it.

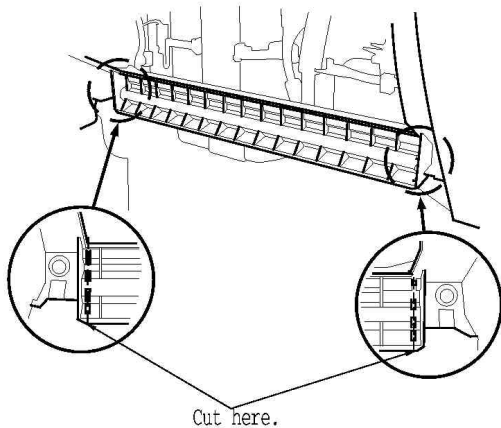

3. Remove the bolts, the screws and the glove box frame.

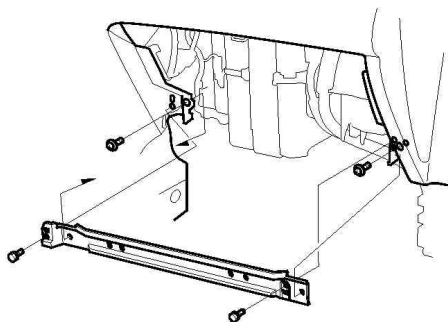

4. Remove the filter lid (A) from the evaporator, then pull out the dust and pollen filter (B).
5. Install the filter in the reverse order of removal. Make sure that there is no air leaking out of the evaporator.
6. Install the glove box frame and glove box in the reverse order of removal.

INTERACTIVE NETWORK

