



INSTALLATION INSTRUCTIONS

Accessory

ATF COOLER KIT
P/N 06255-P7T-305

Application

ODYSSEY

Publications No.

All 22024

Issue Date

AUG 2000

PARTS LIST

ATF Cooler

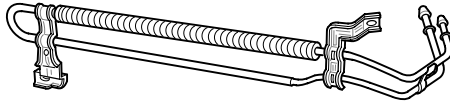

Rubber hose

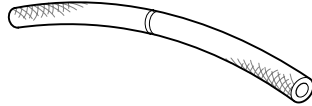

Washer-bolt, 6 x 15 mm



2 Bolts, 6 x 10 mm (not used)



Bracket (not used)

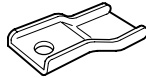

3 Hose clamps



Hose spacer



Mirror "hang tag"



TOOLS AND SUPPLIES REQUIRED

Phillips screwdriver

Flat-tip screwdriver

Ratchet

10 mm and 12 mm Sockets

Pliers

Piece of cardboard

INSTALLATION

Customer Information: The information in this installation instruction is intended for use only by skilled technicians who have the proper tools, equipment, and training to correctly and safely add equipment to your car. These procedures should not be attempted by "do-it-yourselfers."

NOTE: Let the ATF oil and the surrounding parts cool down before you install the ATF cooler.

1. Remove the front bulkhead cover (11 clips).

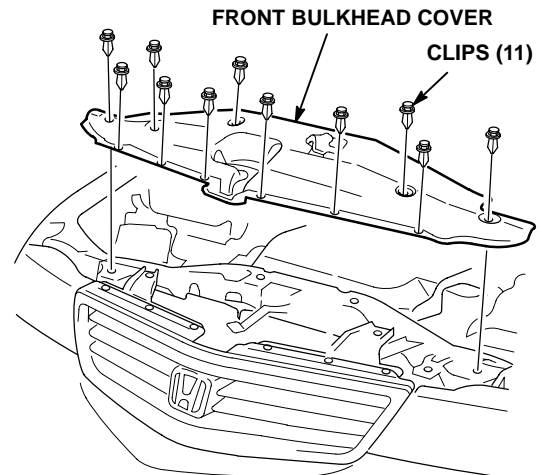

2. Remove the front bumper:

- Remove the four clips and two bolts along the bottom of the bumper.
- Remove one screw from the inside of each fenderwell.
- Lift the bumper off of the hooks, and set the bumper on a piece of cardboard while you install the ATF cooler.

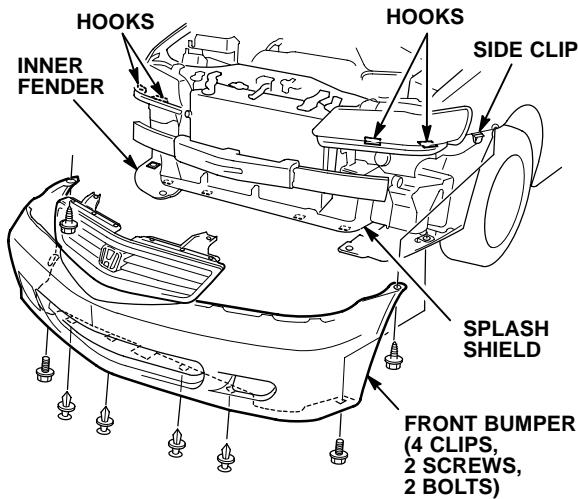

3. Remove the bolt securing the right (passenger's) side power steering cooler bracket.

4. Place the ATF cooler lower bracket over the power steering cooler bracket, and reinstall the bolt through the ATF cooler bracket and the power steering cooler bracket. Install the 6 x 15 mm washer-bolt (supplied) through the upper bracket of the ATF cooler bracket and into the threaded hole in the radiator bulkhead. Tighten both bolts securely.

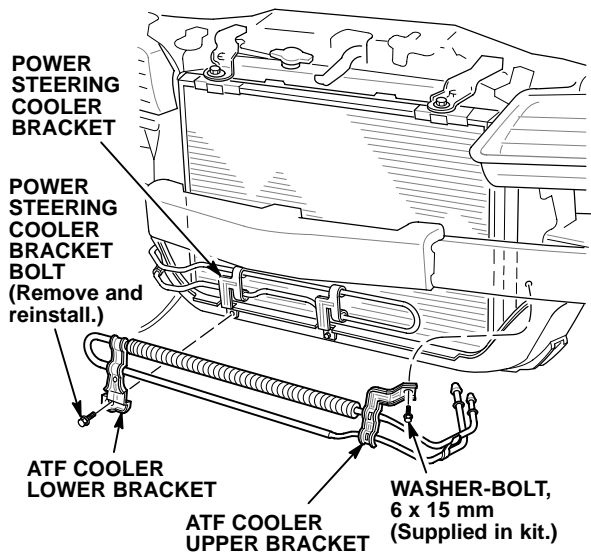

5. Remove the ATF return line from the radiator return pipe, and attach it to the lower ATF cooler pipe using one new hose clamp from the kit.

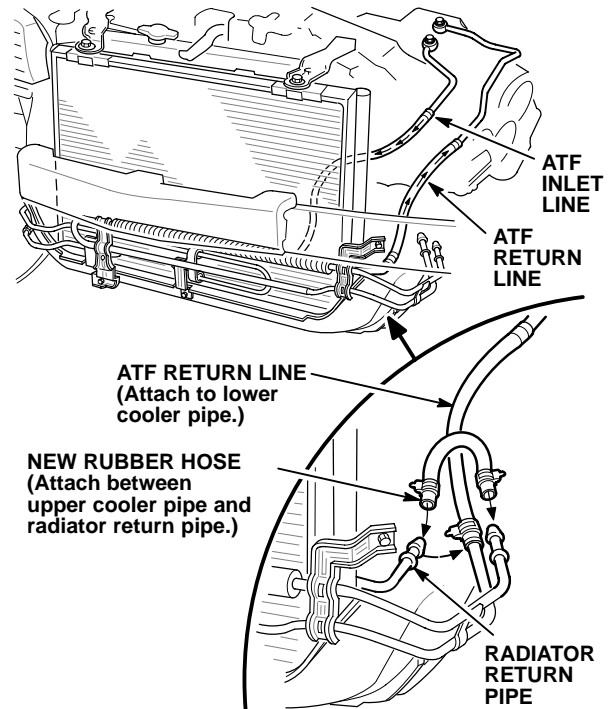

6. Attach one end of the new rubber hose (supplied) to the upper pipe on the ATF cooler, and attach the other end to the radiator return pipe using the remaining two new hose clamps.

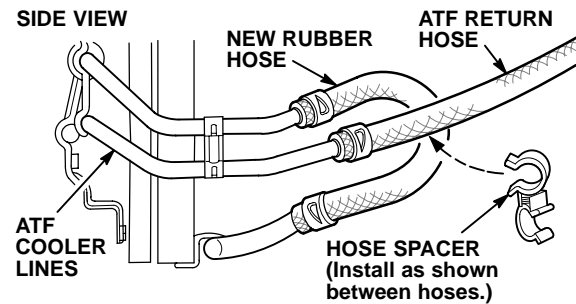

7. Separate the new hose and the ATF return line by installing the hose spacer (supplied) between the two hoses on the area shown.
8. Reinstall the front bumper and the front bulkhead cover.
9. Start the vehicle and check for leaks; repair as necessary.
10. Check the ATF fluid level and adjust as necessary.
11. Attach the hang tag around the rear view mirror.