

**PARTS LIST**

Cassette player

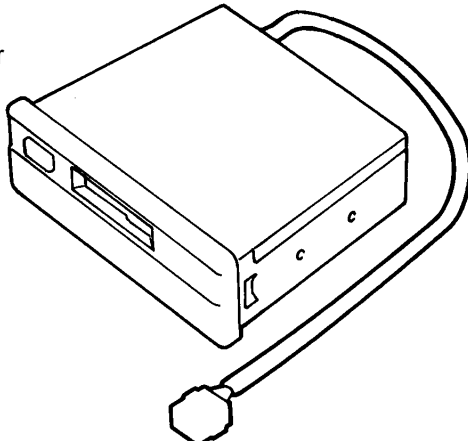

Owner's manual

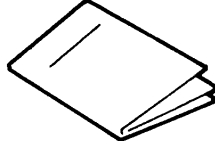

5 Washer-screws



Wire tie (not used)

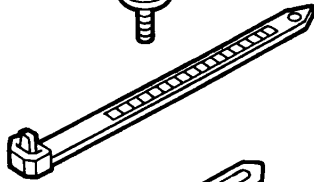

Harness clip

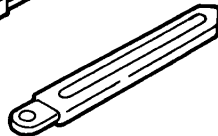
**TOOLS REQUIRED**

Phillips screwdriver

Small flat-tip screwdriver

**INSTALLATION**

1. Make sure you have the anti-theft code for the radio, then write down the frequencies for the preset buttons.
2. Disconnect the negative cable from the battery.

**3. Remove the console cover:**

- Move the gear selector lever to the 1 position.
- Using a small flat-tip screwdriver around a shop towel, gently pry out and remove the cover.
- Reach inside the cover hole, gently pull along the bottom to release the lower clips, and work toward the top to release all 10 clips.
- Pull out on the console panel, unplug the connectors, and remove the panel.

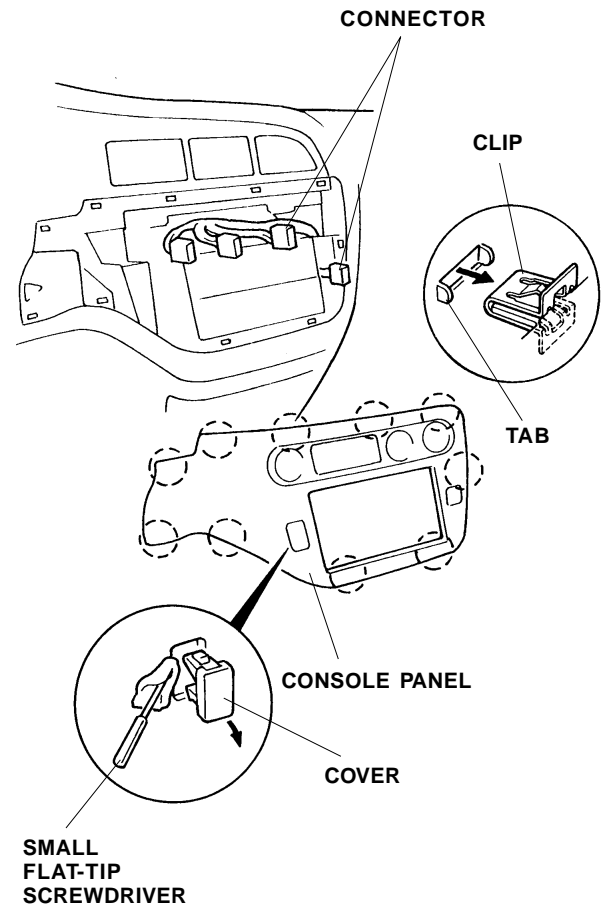

- Remove the radio (four bolts, and unplug the connector and antenna lead).

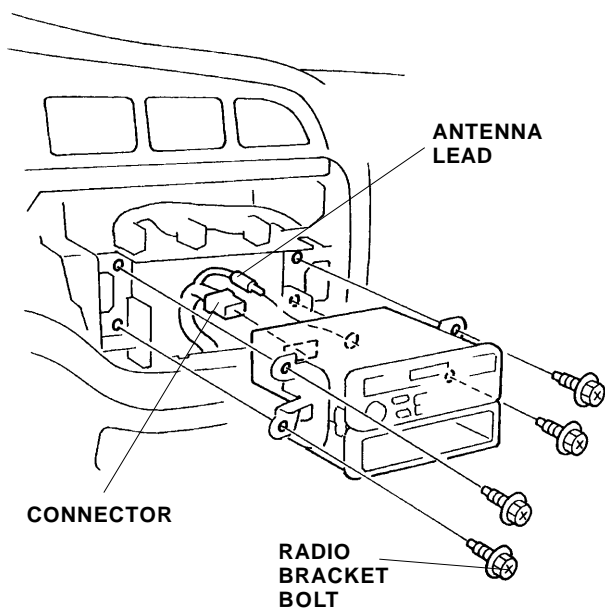

- Remove the left and right radio brackets (two washer-screws for each bracket).

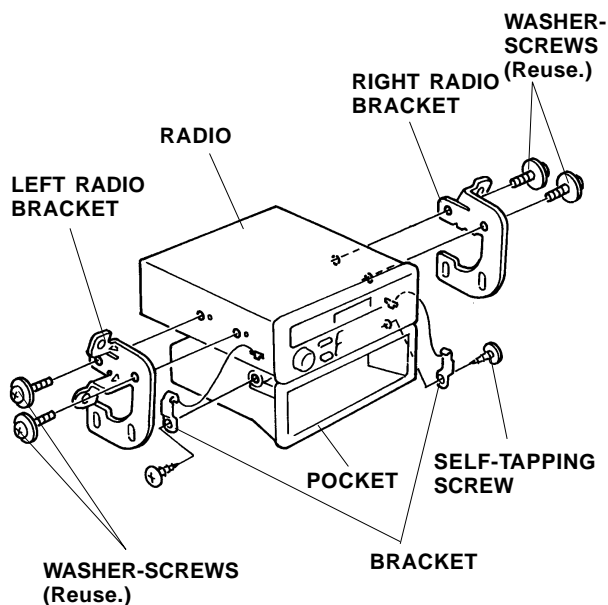

- Remove the pocket (two self-tapping screws), then separate the radio and pocket. Set the pocket aside, it will not be reused.

- Position the cassette player on the radio, and reinstall the left and right radio brackets and four washer-screws removed in step 5. Use four 5 x 8 mm washer-screws (supplied) to secure the cassette player to the radio brackets.

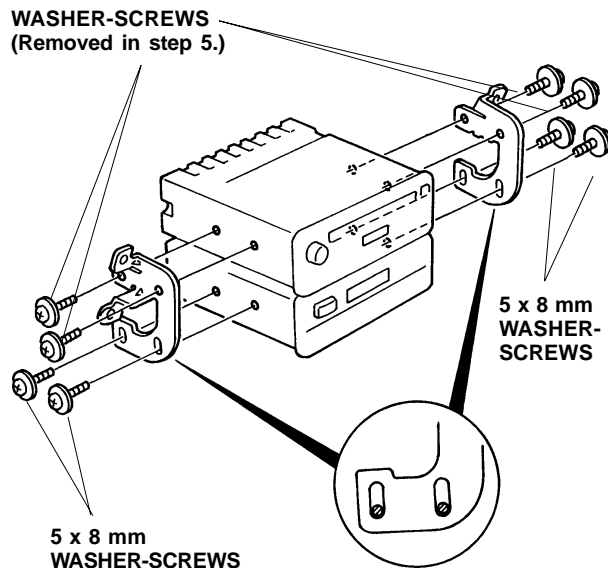

- Attach the harness clip to the back of the cassette player with the remaining 5 x 8 mm washer-screw. Plug the BUS cable into the rear of the radio/cassette player; then fold the excess BUS cable several times, and secure it to the back of the cassette player with the harness clip.

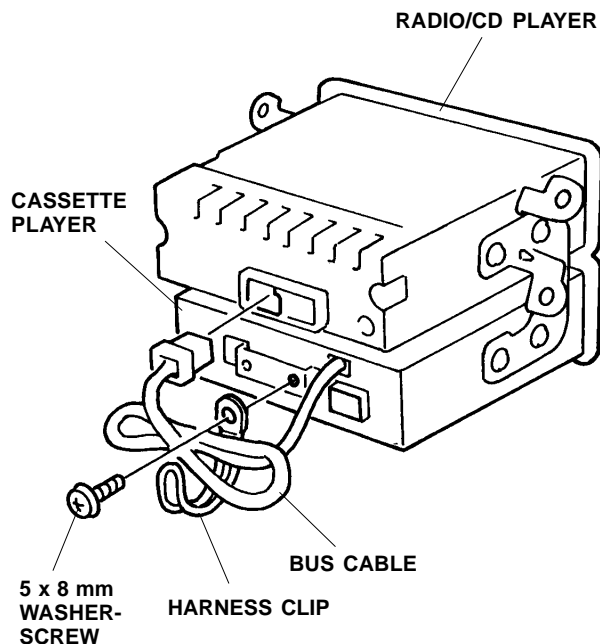

9. Plug the radio connector, and the antenna lead into the back of the radio/cassette player; then reinstall the radio in the dash. If the vehicle is equipped with an optional CD changer, plug the CD changer BUS cable into the cassette player.

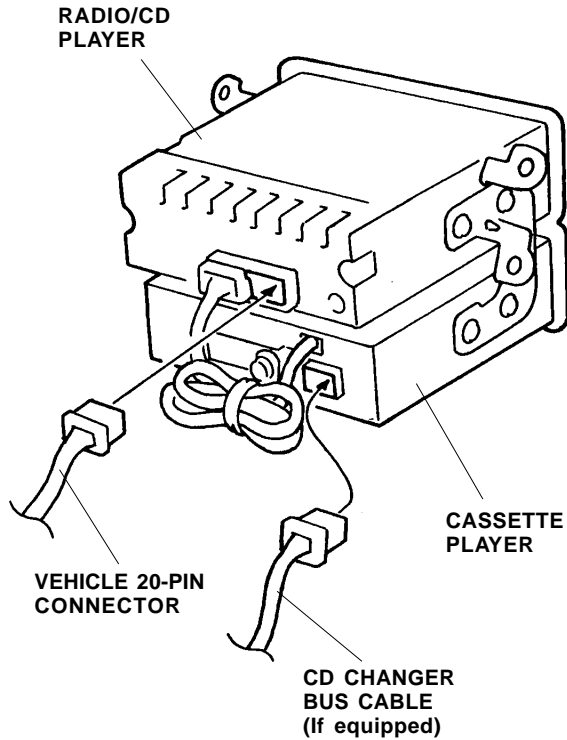

10. Reinstall the console panel; be careful not to damage the tabs.

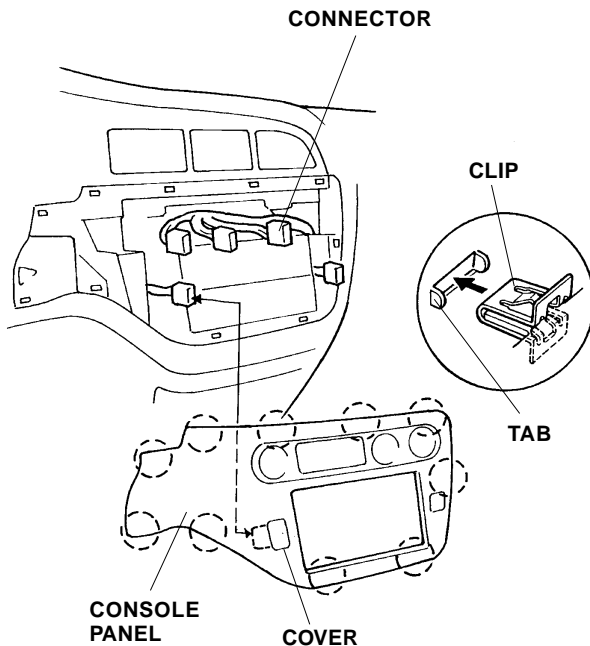

11. Reconnect the negative cable to the battery.
12. Check the operation of the cassette player according to its Owners Manual.
13. Enter the radio anti-theft code, and reset the customer's radio station presets.
14. Reset the clock.
15. Put the cassette player Owner's Manual in the glove box.