



# INSTALLATION INSTRUCTIONS

Accessory

SEPARATION NET  
P/N 08U36-S9V-101

Application

2006 PILOT

Publications No.

All 30511

Issue Date

SEP 2005

Put this information in the glove box with the vehicle owner's manual.

## PARTS LIST

Separation net

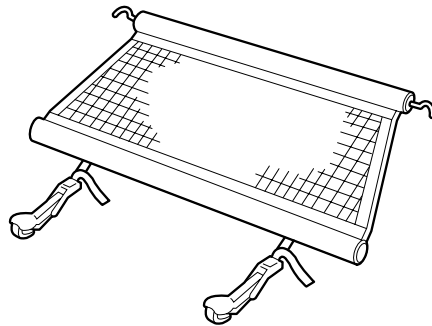

## TOOL REQUIRED

Small flat-tip screwdriver

## INSTALLATION

1. Using a small flat-tip screwdriver or the ignition key, release the seat belt lower hook from each third row seat. Attach the seat belt clips to the seat belts.

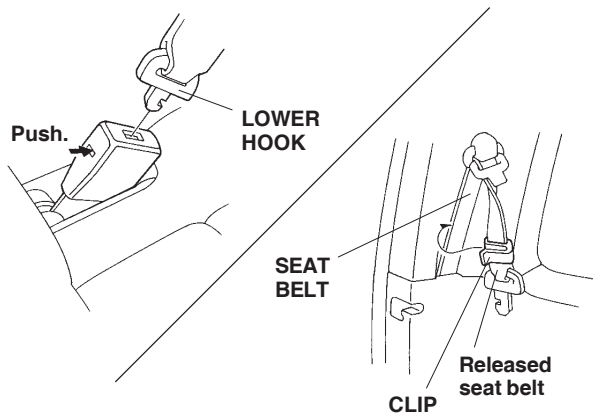

2. Remove the headrests from the third row seats by pushing the release buttons and pulling the headrests out.

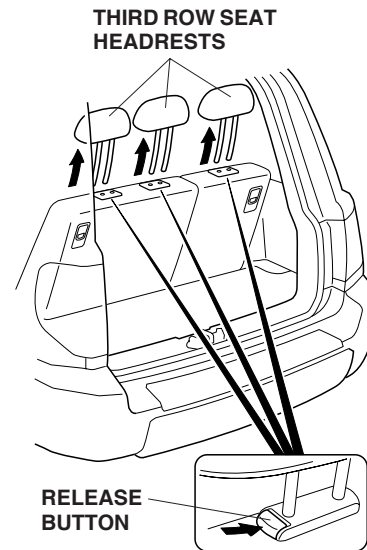

3. Store the headrests in the storage compartment under the cargo floor. Insert the posts of the headrests into the holes in the front of the storage compartment.

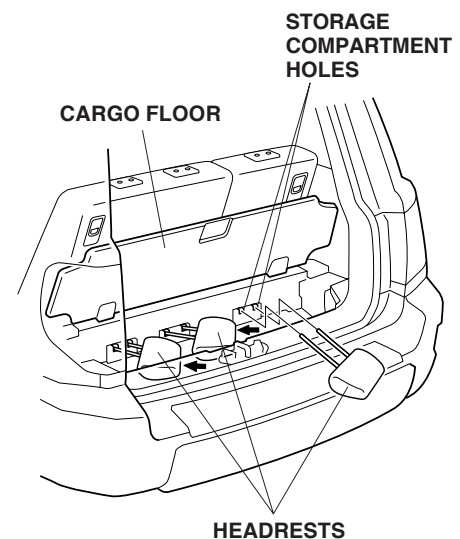

4. Fold down both third row seats.

- Set the separation net into position in the cargo area with the information label facing the rear of the vehicle. Insert the steel rods into the grab rails, and turn the net holder 90° to lock it into position.

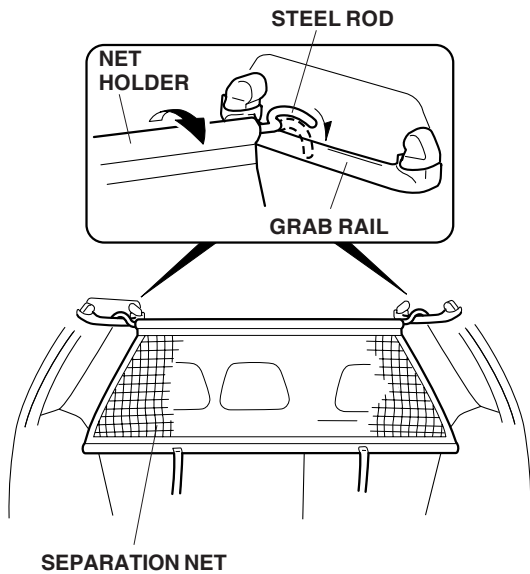

- Extend the hooks of the separation net, and attach the hooks to the “D” rings on the rear side panels.

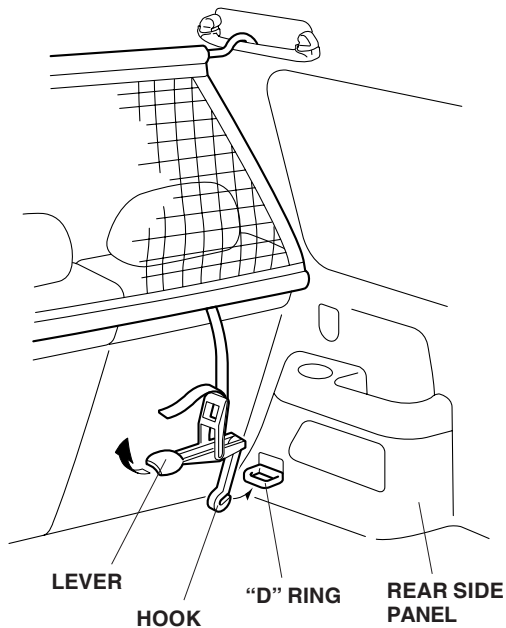

- Adjust the length of the straps as needed. Lower the handle and snap the lever closed against the hook.

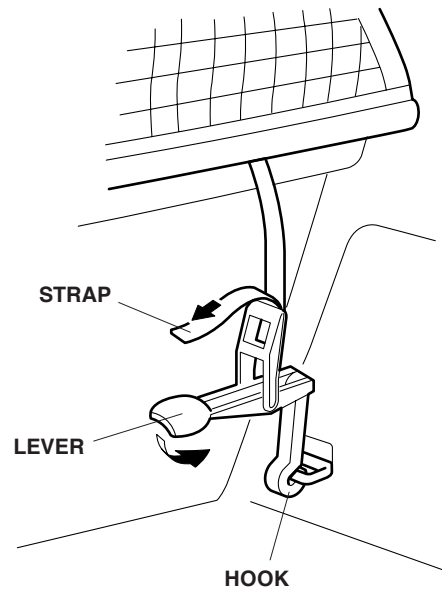

#### USE OF THE SEPARATION NET

Follow these guidelines:

- Do not allow the height of the cargo area to exceed the height of the seat-back.
- Make sure you place the heaviest cargo directly on the floor.
- Do not hang articles on the net or the frame.
- Before driving with cargo stowed, check that the steel rods are attached properly and the lower straps are pulled taut. If the separation net is not properly attached, cargo may fall into the passenger area when the vehicle is moving.