



# INSTALLATION INSTRUCTIONS

Accessory  
**18" ALUMINUM WHEEL**  
P/N 08W18-SZA-100

Application  
**2009 PILOT**

Publications No.  
**All 39416**  
Issue Date  
**MAY 2008**

## PARTS LIST

Aluminum wheel  
(The illustration may differ from the actual wheel.)



Wheel center cap  
(The illustration may differ from the actual center cap.)

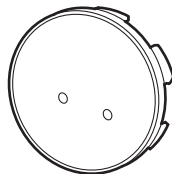

Center cap emblem



2 Push nuts



Tire pressure information label



TPMS Information  
(Give this information to your customer.)

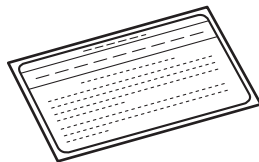

Wheel cleaning information  
(Give this information to your customer.)

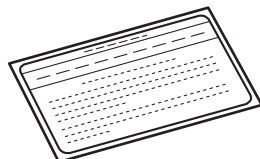

## Parts for TPMS sensor assembly

Tire pressure sensor assembly

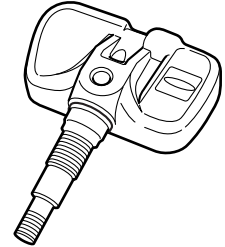

Washer



Valve nut



## TOOLS AND SUPPLIES REQUIRED

- Ratchet wrench
- 11 mm Socket
- Torque wrench
- Isopropyl alcohol
- Shop towel
- HDS
- Snap-on TPMS sensor initialize tool

## SPECIFICATIONS

### Models not equipped with standard 18" wheels:

Rim size	18 x 7 1/2 J (offset 45)	
Tire size	245/60R18 104T	
Bolt hole PCD	120 (5 holes)	
Tire pressure	Front	220 kpa (2.3 kgf/cm <sup>2</sup> , 32 psi)
	Rear	220 kpa (2.3 kgf/cm <sup>2</sup> , 32 psi)

### Models equipped with standard 18" wheels:

Refer to the Owner's Manual.

## INSTALLATION

**Customer Information:** The information in this installation instruction is intended for use only by skilled technicians who have the proper tools, equipment, and training to correctly and safely add equipment to your vehicle. These procedures should not be attempted by “do-it-yourselfers.”

### NOTE:

- This aluminum wheel is designed for use on TPMS (Tire Pressure Monitoring System) equipped vehicles.
- This aluminum wheel is equipped with the TPMS sensor. See the Service Manual for tire replacement procedure and TPMS sensor installation procedure.
- The illustrations of the aluminum wheels are shown for reference purposes only.
- Install the correct size tire.
- Follow the instructions described in the Owner's Manual when jacking up the vehicle and removing and installing the wheels. Do not overtighten the wheel nuts by placing your weight on the wrench or by using a pipe for added leverage.  
Wheel nut torque: 108 N·m (11 kgf·m, 80 lbf·ft).
- Use a tire changer to install and remove the tires as described in the Operation Manual furnished with the tire changer. Do not use a tire lever to install and remove the tires as it may cause damage to the tire and aluminum wheel.
- Be careful not to damage the wheel center cap when installing the emblems.
- This center cap emblem should be installed only if the ambient air temperature is 15°C (60°F) or above.
- To allow the adhesive to cure, do not wash the vehicle for 24 hours.

1. Using isopropyl alcohol on a shop towel, clean the area where the center cap emblem will attach.

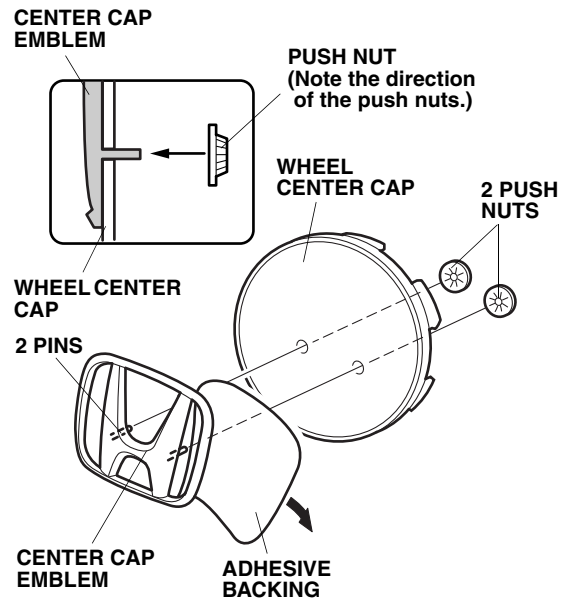

2. Remove the adhesive backing from the center cap emblem.
3. Attach the center cap emblem to the wheel center cap by aligning its pins with the holes in the wheel center cap. After attaching, hold the emblem firmly against the wheel center cap with the palm of your hand for 30 seconds.
4. Slide the two push nuts onto the two pins. Note the direction of the push nuts.

- Before installing the tire pressure sensor, clean the mating surface on the sensor and the aluminum wheel.

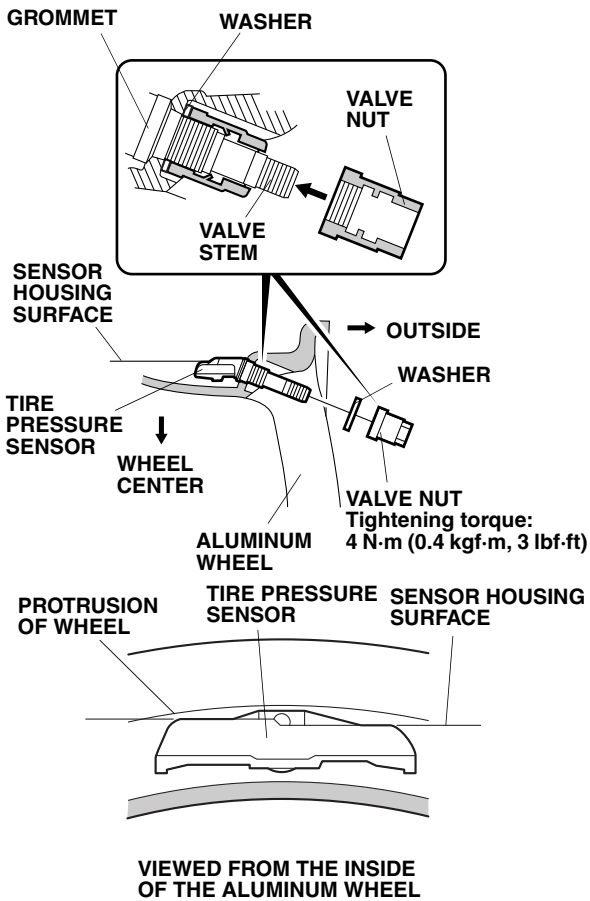

- Install the tire pressure sensor and the washer on the aluminum wheel, and tighten the valve nut finger tight. Make sure the pressure sensor is resting on the wheel.
- Tighten the valve nut to the specified torque while holding the tire pressure sensor toward the wheel. Tightening torque: 4 N·m (0.4 kgf·m, 3 lbf·ft)

**NOTE:**

- Install the tire pressure sensor so that the sensor housing surface does not protrude into the bead area of the wheel to prevent the sensor housing from being caught on the bead of the tire when installing the tire.

**NOTE:**

- Do not reuse grommets that had been tightened, even one time, to the specified torque, as they are deformed inside.
  - Do not use pneumatic or electric tools on the valve nut.
  - Tightening the nut to the specified torque or above can damage the grommet.
- Install the tires according to the instructions in the Service Manual.
  - Install wheels on the vehicle and torque to 108 N·m (11 kgf·m, 80 lbf·ft).

## MEMORIZING THE TIRE PRESSURE SENSOR ID

- Using the HDS and Snap-on TPMS sensor initializer tool, memorize the tire pressure sensor ID according to the instructions in the Service Manual (Memorizing the Tire Pressure Sensor ID).

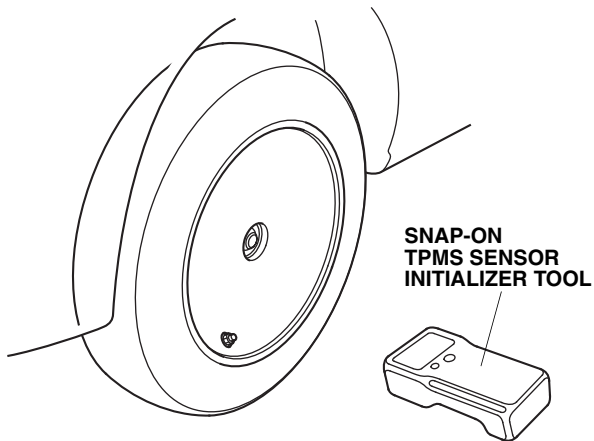
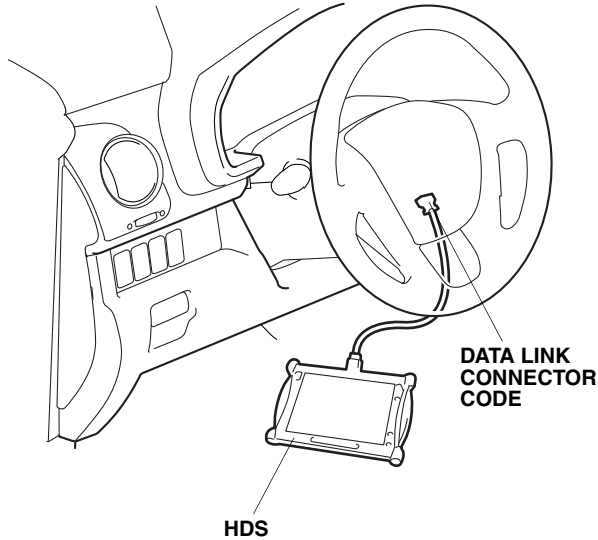

## Do steps 11 and 14 for models not equipped with standard 18" wheels.

- Open the driver's door. Using isopropyl alcohol, thoroughly clean the area where the Tire Pressure Information Label will attach. Remove the adhesive backing from the label, and attach it on the standard tire information label as shown.

Attach the accessory tire pressure information label to prevent mistake.

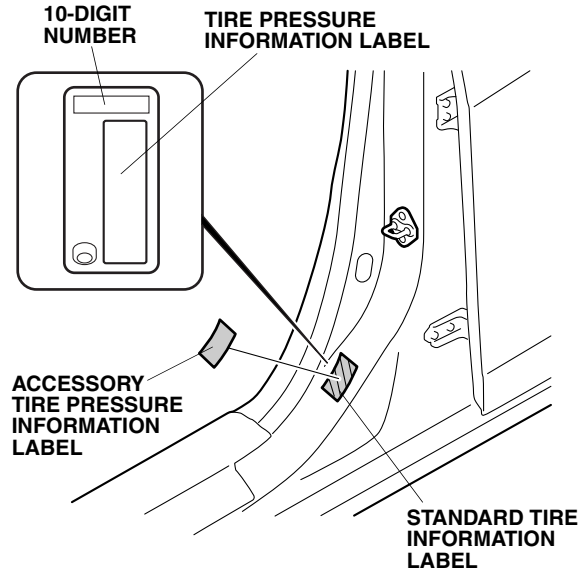

- Insert the "Supplemental Information" page included in this kit into the Owner's Manual. For the method of attaching the page, refer to "To the dealer" attached to the "Supplemental Information" page.

13. Do the Inch-up Tire Pressure programming procedure as follows.

### **INCH-UP TIRE PRESSURE PROGRAMMING (LOW AIR PRESSURE WARNING THRESHOLD REPROGRAMMING)**

1. After doing the sensor ID learning using the HDS, back up to the TPMS Mode Menu, and click on Threshold Rewriting.
2. Select "Reprogramming for accessory tires".
3. When the HDS says, "Do you want to rewrite the threshold data?" click "YES".
4. Check that "Please enter the tire information code of new tires" is shown, and click the "Keyboard" icon.
5. Enter the 10-digit tire information code printed on the new tire pressure information label, then click the check icon.
6. Check that the tire pressure shown on HDS, and the new tire pressure on the tire information label are the same, click the "YES" button for programming.
7. Check that the current air pressure setting shown on HDS is correct and "Reprogramming the threshold data for non-standard tires has completed successfully" is shown.
8. After programming, write the tire pressure indicated on the HDS in the service history page for Honda Accessory Wheels, then click the check icon.
9. After programming, sign on the service history page for the Honda Accessory wheels, according to the procedure on page 7.

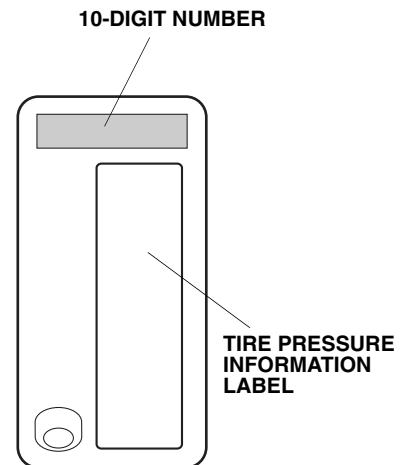
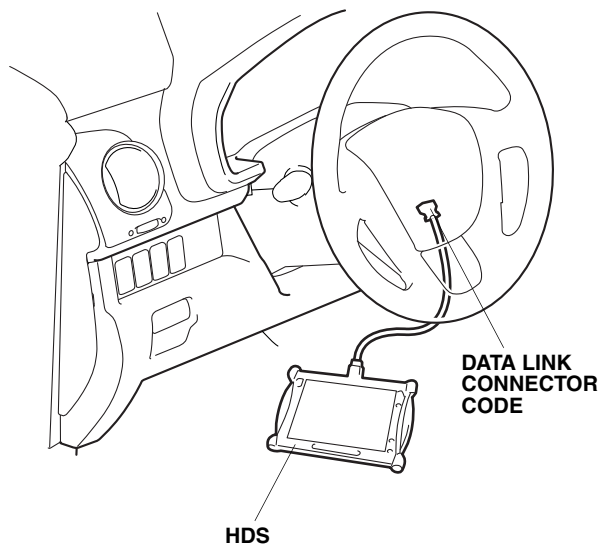

14. After finishing the work, write tire size, tire pressure, HDS version, dealer name, technician's signature and date in "Service History Page for Honda Accessory Alloy wheels" page included in this kit and attach to the vehicle's service history booklet.

- Be sure explain the contents of the "Supplemental Information" to your customer before delivering the vehicle.
- Be sure to give the wheel cleaning information and TPMS information to your customer.

## **STANDARD TIRE PRESSURE PROGRAMMING**

If the original equipment (standard) tires are to be installed back on the vehicle, memorize the tire pressure sensor ID and change the low pressure warning threshold back; follow the procedure on page 9.

NOTE: Have the standard tire pressure label on hand.

## **THRESHOLD DATA CHECK**

If for some reason you are unsure of where the low pressure warning threshold is set, it can be checked by using the Threshold Data Check; follow the procedure on page 10.

## **TPMS Control Unit Replacement**

If the TPMS control unit is ever replaced and the vehicle has inch-up wheels, the low pressure sensor threshold must be changed. Once the TPMS control unit is installed, follow steps 10 to 14 (which includes memorizing ID and programming for accessory tires).

## STANDARD TIRE PRESSURE PROGRAMMING

To return the TPMS programming from the inch-up tire to the standard tire, memorize the tire pressure sensor ID and change the tire pressure programming.

1. Install the standard tires, and memorize the tire pressure sensor ID according to the instructions in Service Manual.
2. Change the tire pressure programming (the low air pressure warning threshold):
  1. Connect the HDS to the vehicle, make sure the correct VIN is populated, and enter the mileage.
  2. At the System Selection Menu, click TPMS.
  3. At the Mode Menu, click on DTCs and clear any stored codes.
  4. Go back to the Mode Menu, and click on Threshold Rewriting.
  5. Click on Reprogramming for standard tires, and follow the screen prompts.
  6. After programming, write the standard tire pressure in the supplemental information, then click the check button.
  7. Attach the tire pressure information label for standard tires at the prescribed location.
  8. After programming, write the following information on the service history page for Honda Accessory wheels.

Write tire size, tire pressure, HDS version, dealer name, technician's signature and date in service history page for Honda Accessory Alloy wheels page attached on the vehicle's Service history booklet.

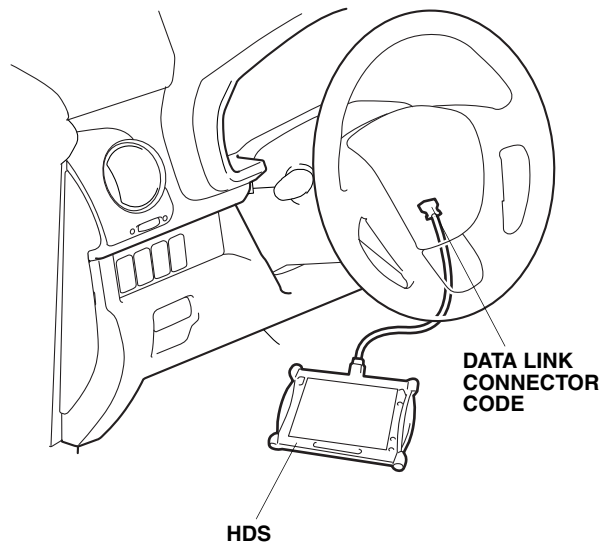

## THRESHOLD DATA CHECK

Check the TPMS programming of the pressure on the vehicle:

1. Connect the HDS to the vehicle and make sure the correct VIN is populated and enter the mileage.
2. At the System Selection Menu, click TPMS.
3. Click on Threshold Rewriting.
4. Click on Threshold Data Check.

