



INSTALLATION INSTRUCTIONS

Accessory

FRONT LOWER TRIM
P/N 08P46-SZA-100

Application

2009 PILOT

Publications No.

All 39411

Issue Date

MAY 2008

NOTE: The front lower garnish can not be installed on vehicle equipped with full nose mask or front trim.

PARTS LIST

Front lower trim

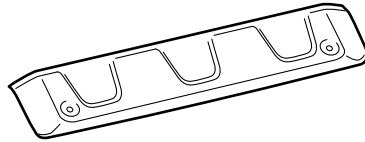

2 Rivet nuts



2 Special bolts



2 Washers



2 Spacers



TOOLS AND SUPPLIES REQUIRED

#2 Phillips screwdriver

Ratchet

10 mm Socket

Hex wrench

Pushpin

Drill

3 mm and 10 mm Drill bits

Eye protection (safety goggles, face shield, etc.)

Rivet nut tool

Hex wrench

19 mm wrench

Blanket

Illustration of the Front Lower Trim kit Installed on the Vehicle

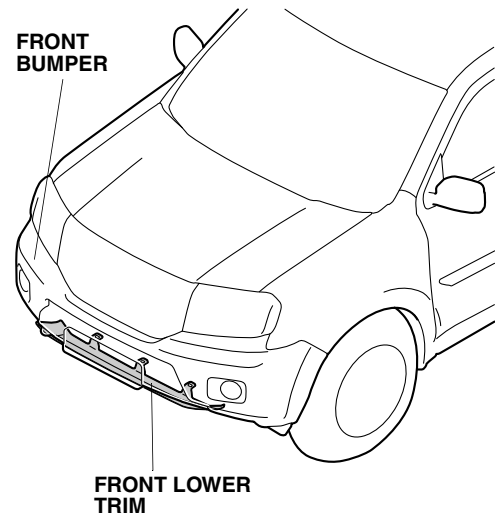

INSTALLATION

Customer Information: The information in this installation instruction is intended for use only by skilled technicians who have the proper tools, equipment, and training to correctly and safely add equipment to your vehicle. These procedures should not be attempted by “do-it-yourselfers.”

NOTE:

Be careful not to damage the body paint finish. To prevent damage, place a blanket under the front bumper during the installation.

1. Remove the front bulkhead cover (nine clips).

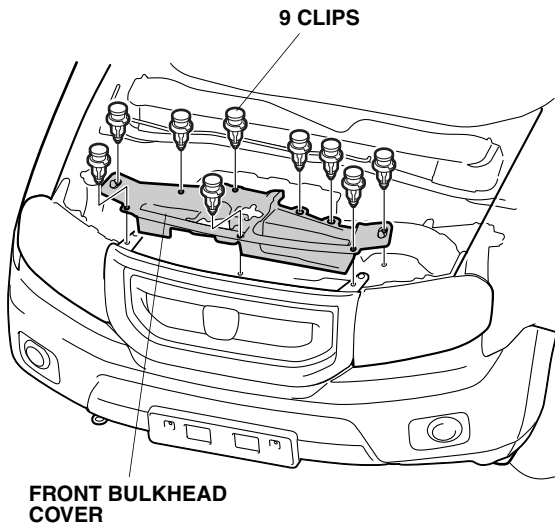

2. Remove the front bumper (nine clips, four bolts, and four self-tapping screws). Have an assistant help you when removing and installing the front bumper. If the vehicle is equipped with the foglight or the front corner sensors, unplug the connectors.

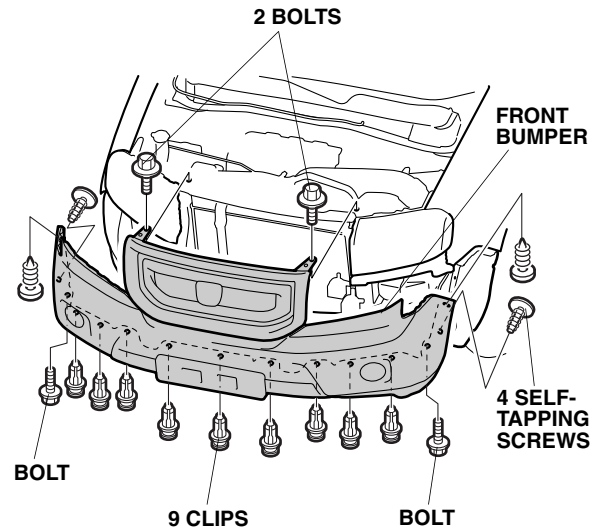

3. Inside the front bumper, mark the center of the two scribe marks with a pushpin as shown.

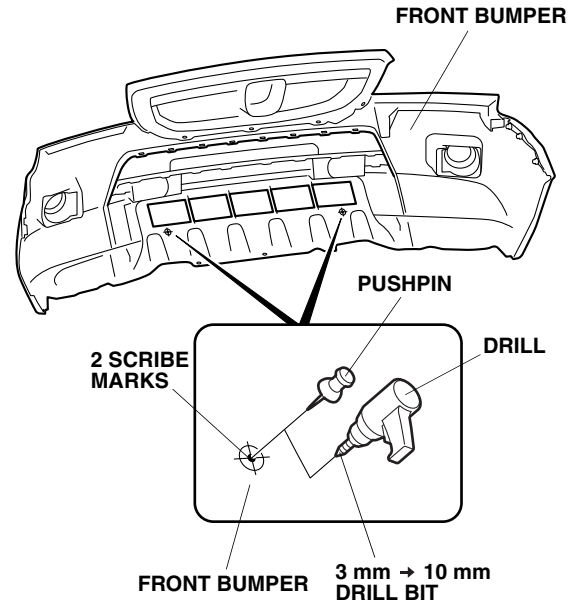

4. While wearing eye protection, first drill with a 3 mm drill bit and finish with a 10 mm drill bit, and remove all burrs.

- 5. Install the two rivet nuts to the front bumper as shown.

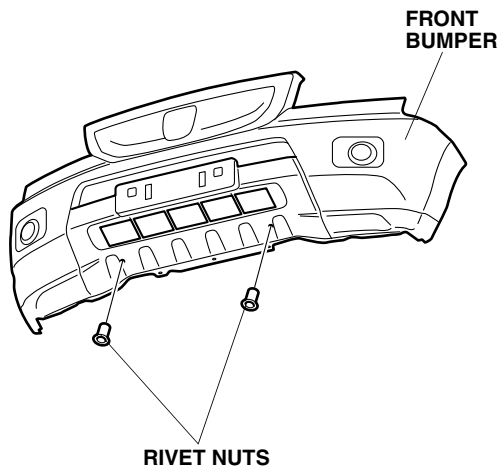

- Screw the rivet nut onto the mandrel of the rivet nut tool as shown.

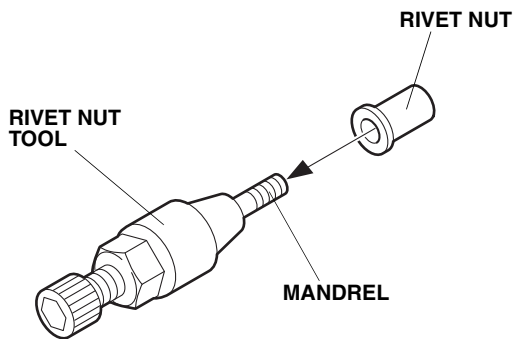

- Insert the rivet nut into the hole in the front bumper and install the hex wrench on the rivet nut tool.

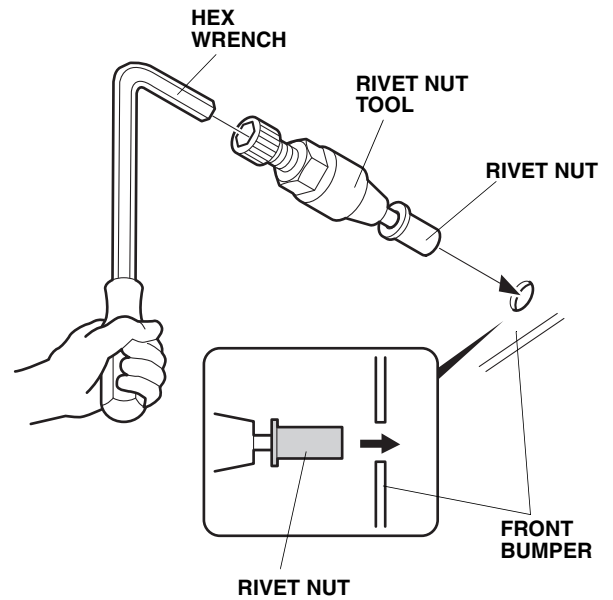

- Holding the rivet nut tool with the hex wrench, turn the 19 mm wrench clockwise and install the rivet nut on the front bumper.
- Remove the rivet nut tool from the rivet nut by turning the hex wrench counterclockwise.

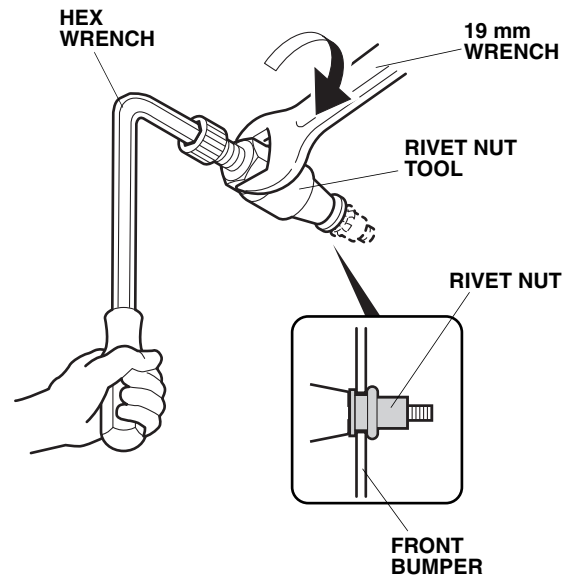

- Position the front lower trim to the front bumper, and install the two washers, two spacers, and two special bolts as shown. Torque the special bolts to 4 N·m (0.4 kgf·m, 3 lbf·ft).

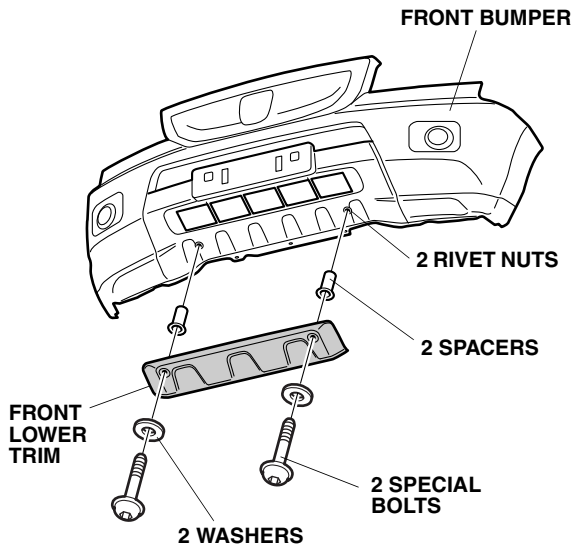

- Reinstall the front bumper.

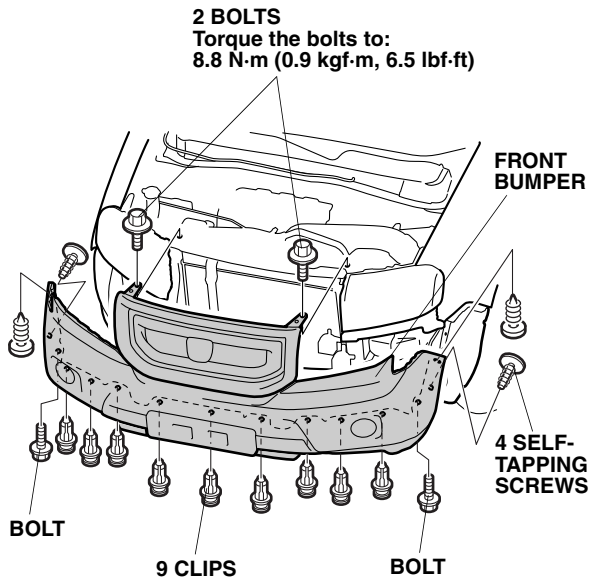

- Reinstall all removed parts.