



INSTALLATION INSTRUCTIONS

Accessory

CASSETTE PLAYER/
In-DASH CD CHANGER

Application

PILOT (LX)

Publications No.
All 23606

Issue Date
MAY 2002

PARTS LIST

Cassette Player :
P/N 08A03-5B1-050

Cassette player

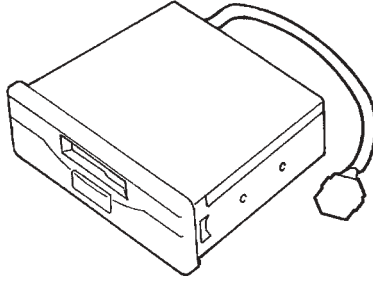

Owner's Manual

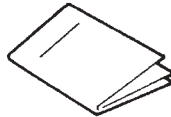

7 Washer-screws
(2 not used)



Wire tie (not used)

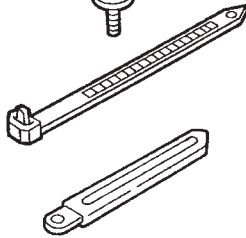

Harness clip

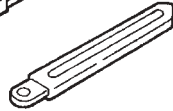

In-Dash CD Changer :
P/N 08A06-3B1-300

In-Dash CD changer

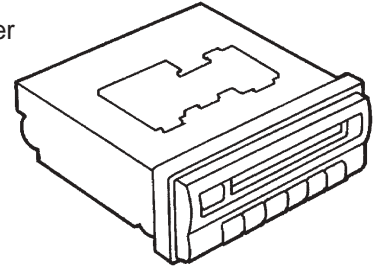

Owner's Manual

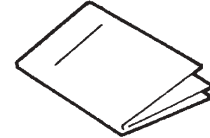

6 Washer-screws, 5 x 8 mm
(2 not used)



Washer-screw, 4 x 6 mm



Wire tie (not used)

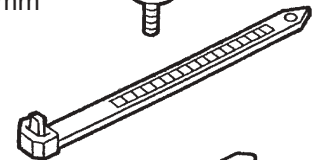

Harness clip

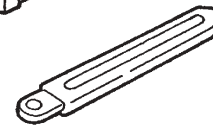

Adhesive strips
(1 not used)

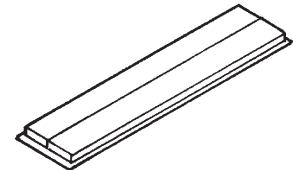

TOOLS AND SUPPLIES REQUIRED

- Phillips screwdriver
- Small flat-tip screwdriver
- Isopropyl alcohol
- Shop towel

INSTALLATION

Customer Information: The information in this installation instruction is intended for use only by skilled technicians who have the proper tools, equipment, and training to correctly and safely add equipment to your vehicle. These procedures should not be attempted by “do-it-yourselfers.”

1. Make sure you have the anti-theft code for the radio, then write down the frequencies for the preset buttons.
2. Disconnect the negative cable from the battery.
3. Using a flat-tip screwdriver wrapped with a shop towel, gently pry out the upper right hand cover of the audio panel. Insert fingers into the opening to release the four clips. Unplug the vehicle connectors and remove the audio panel.

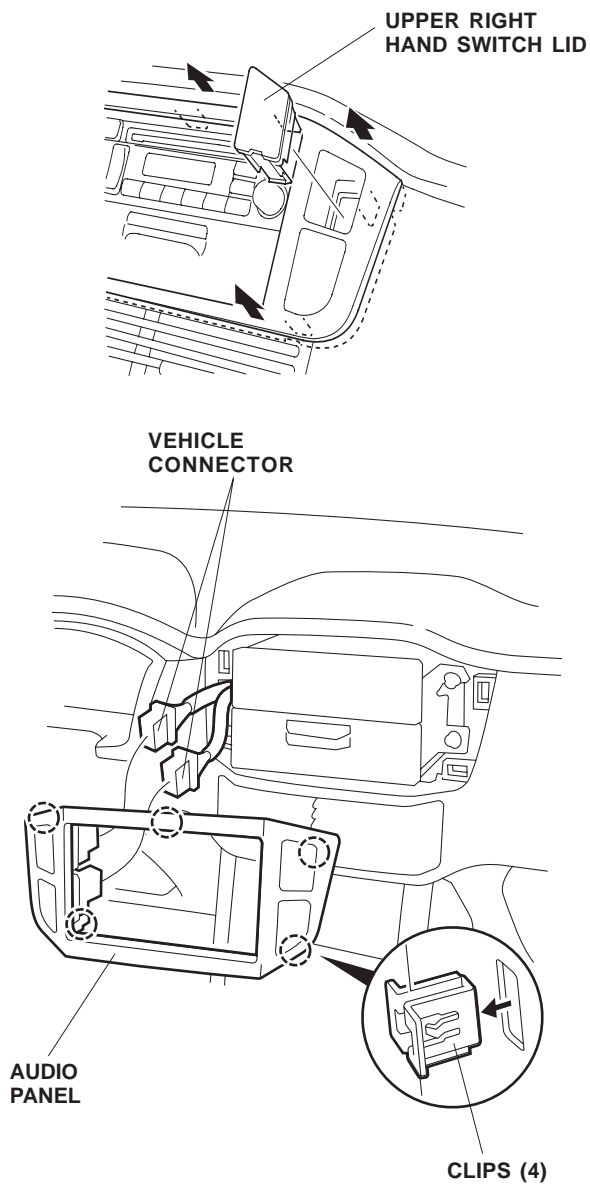

4. Remove the audio unit (four screws, pull the audio unit out toward you, unplug the vehicle connector and antenna lead).

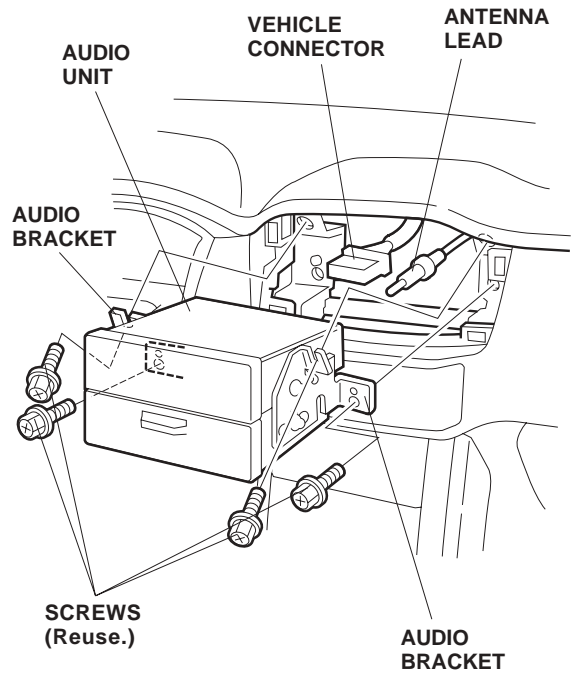

5. Remove the left and right audio brackets (two washer-screws and self-tapping screw for each bracket). Separate the audio unit and pocket. Set the pocket aside, it will not be reused.

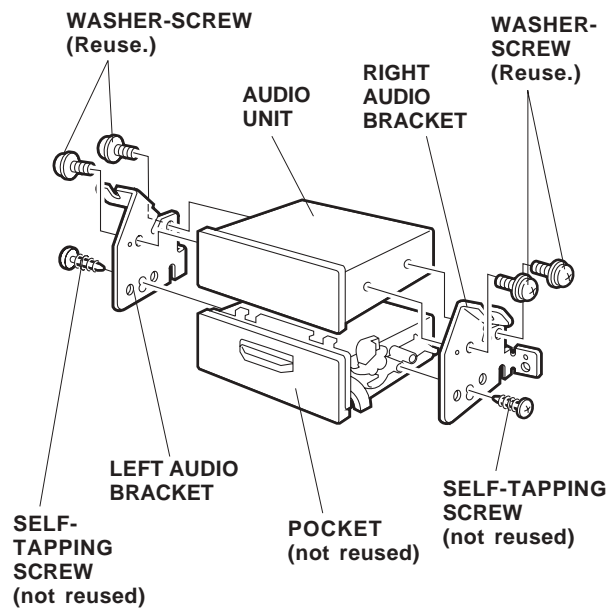

With Cassette Player:

- Set the audio unit on the cassette player and attach the left and right audio brackets using the four washer-screws removed in step 5 to the audio unit.
- Attach the left and right audio brackets using the four 5 x 8 mm washer-screws included in the cassette player to the cassette player (attach in order of ① and ②).

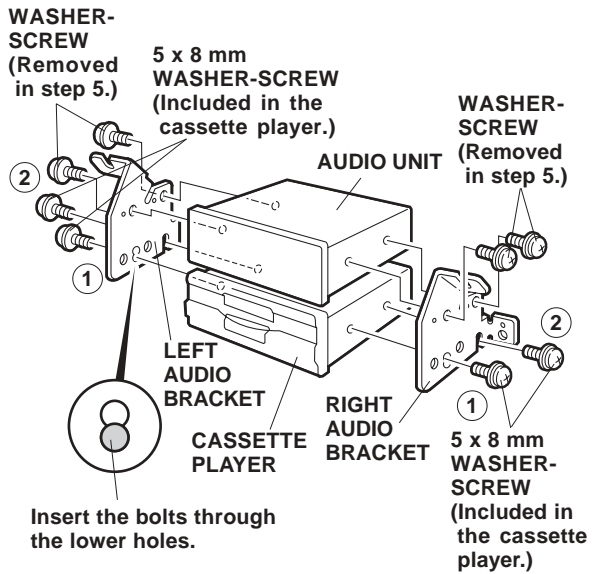

With In-Dash CD Changer:

- Attach one adhesive strip to the bottom of the CD changer.

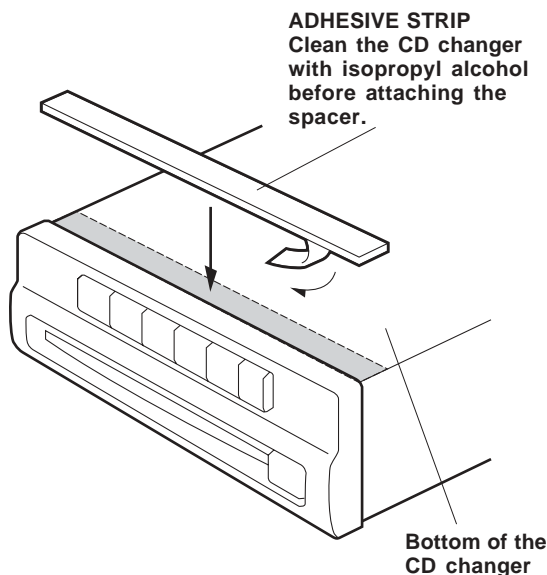

- Set the audio unit on the CD changer and attach the left and right audio brackets using the four washer-screws removed in step 5 to the audio unit.
- Attach the left and right audio brackets using the four 5 x 8 mm washer-screws included in the CD player to the CD changer (attach in order of ① and ②).

WASHER-SCREW (Removed in step 5.)

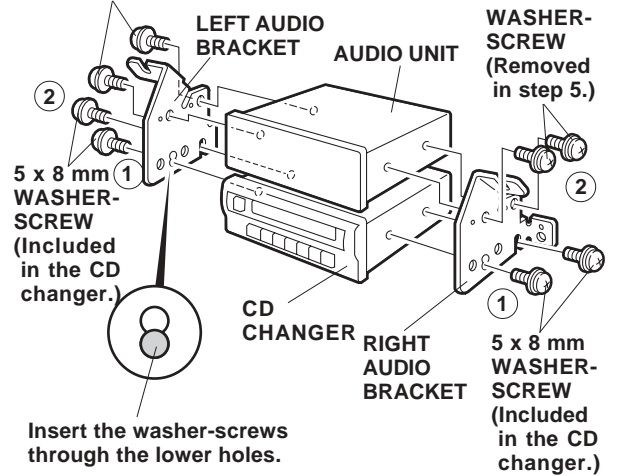

- Attach the harness clip to the back of the changer or player using the 5 x 8 mm washer-screw. Plug the BUS cable connector into the audio unit.

With Cassette Player:

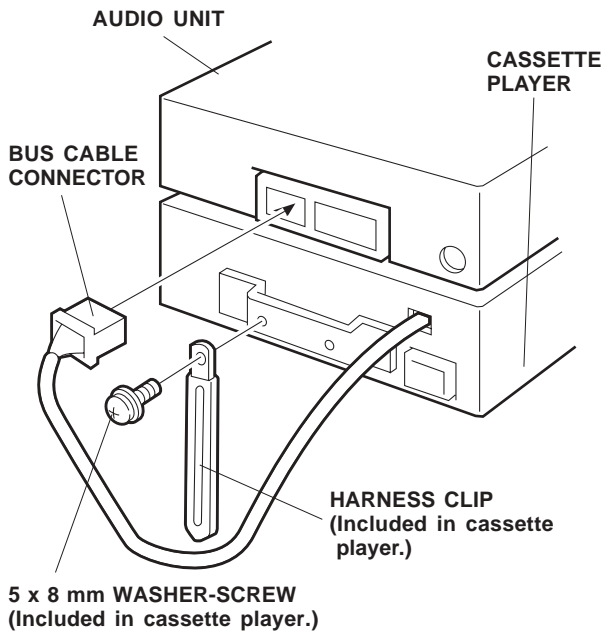

With In-Dash CD Changer:

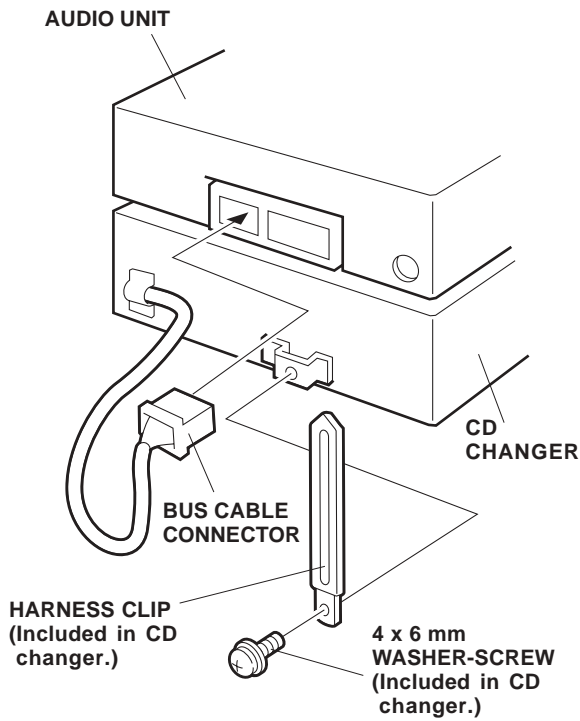

- Bundle up the excess BUS cable and secure it to the changer or player with the harness clip.

With Cassette Player:

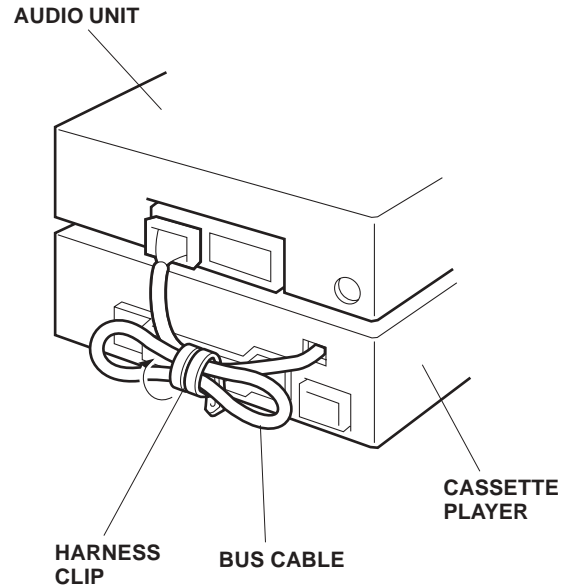

With In-Dash CD Changer:

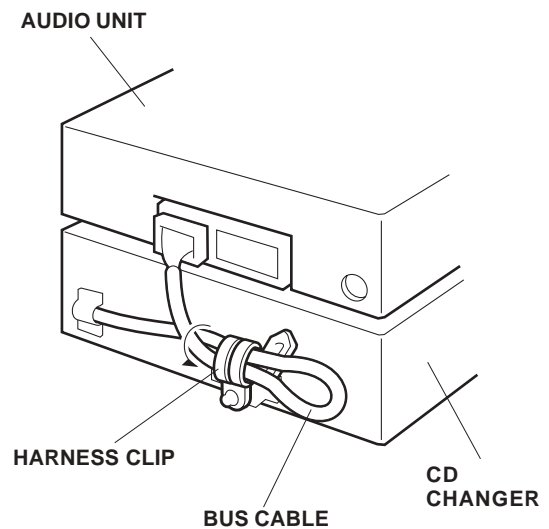

8. Plug in the vehicle connector and the antenna lead into back of the audio unit, then reinstall the audio unit using the four screws removed in the step 4.

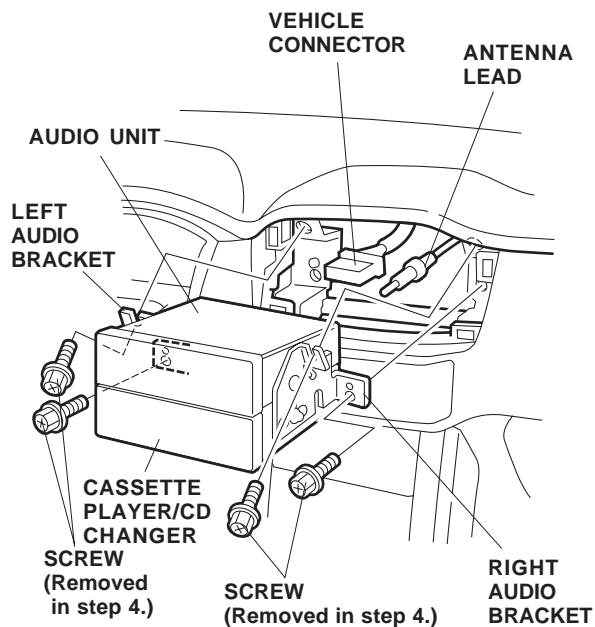

9. Plug in the vehicle connectors, and reinstall the audio panel.

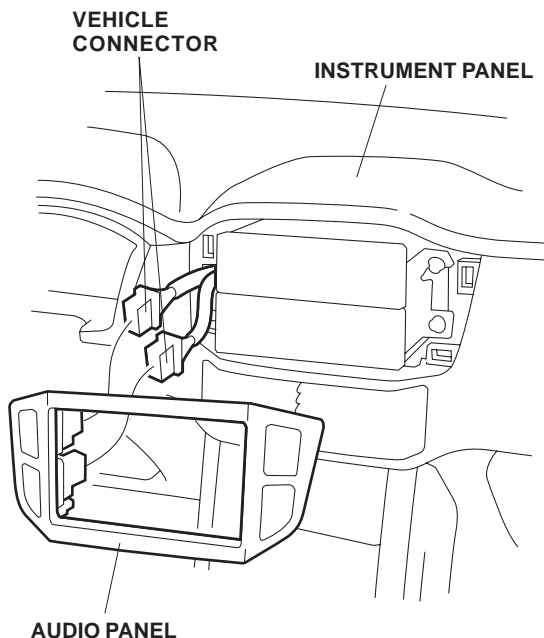

10. Reconnect the negative cable to the battery.
11. Check the operation of the cassette player/CD changer according to the Owner's Manual provided.
12. Put the cassette player/CD changer Owner's Manual in the glove box.
13. Reset the clock and customer's radio station presets.

NOTE: Whenever the battery is disconnected, the driver's window AUTO function is disabled.

14. Start the engine. Push down on the driver's window switch until the window is fully open.
15. Pull up on the driver's window switch to close the window completely, then hold the switch for two seconds.
16. Test the driver's window AUTO function.
17. Do the PCM idle learn procedure.
 - Make sure all electrical items are turned off.
 - Start the engine. Hold the engine speed at 3,000 rpm with no load (in Park or Neutral) until the radiator fan comes on.
 - Let the engine idle for about 5 minutes with the throttle fully closed and with all electrical items off.

NOTE: If the radiator fan comes on during this step, the time when it is operating must not be included in the 5 minutes.