



INSTALLATION INSTRUCTIONS

Accessory	Application	Publications No.
SECURITY SYSTEM	PILOT	All23628
		Issue Date MAY 2002

PARTS LIST

**Security System Kit:
P/N 08E51-S84-100**

2 Remote controls

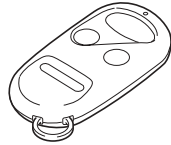

Control unit

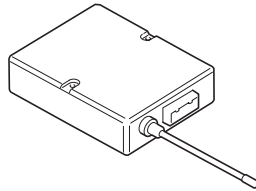

LED



Push nut



2-Pin connector (for LED)



Disarm switch



Window decal



3-Pin connector
(for disarm switch)

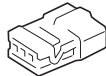

Nut, 12 mm



Washer



Owner's Manual



2 Washer-screws, 4 x 30 mm



**Attachment Kit :
P/N 08E55-S9V-100**

Security system harness

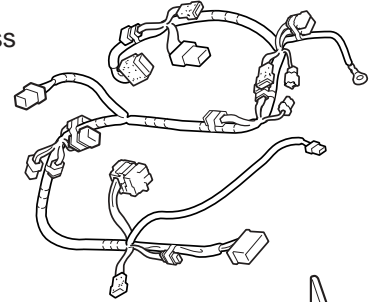

Unit bracket

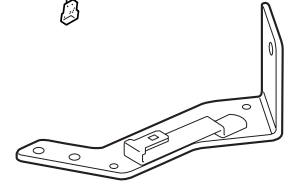

2 Flange nuts



11 Wire ties

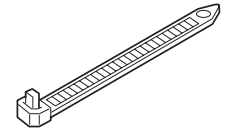

Relay

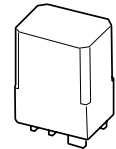

Fuse label

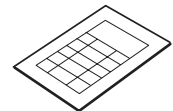

2 Wire ties with clip

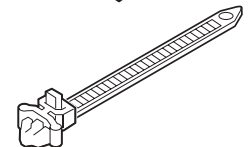

3 Cushion tapes

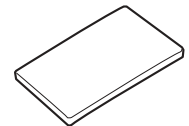

Ground bolt



TOOLS AND SUPPLIES REQUIRED

Phillips screwdriver
Flat-tip screwdriver
8 mm and 10 mm Combination wrenches
Ratchet
10 mm and 12 mm Sockets
Torque wrench
Diagonal cutters
Felt-tip pen
Isopropyl alcohol
Shop towel
Scissors
Drill
5.5 mm Drill bit
12 mm Hole saw
Tape measure
Eye protection (face shield, safety goggles, etc.)

Illustration of Security System Installed on the Vehicle

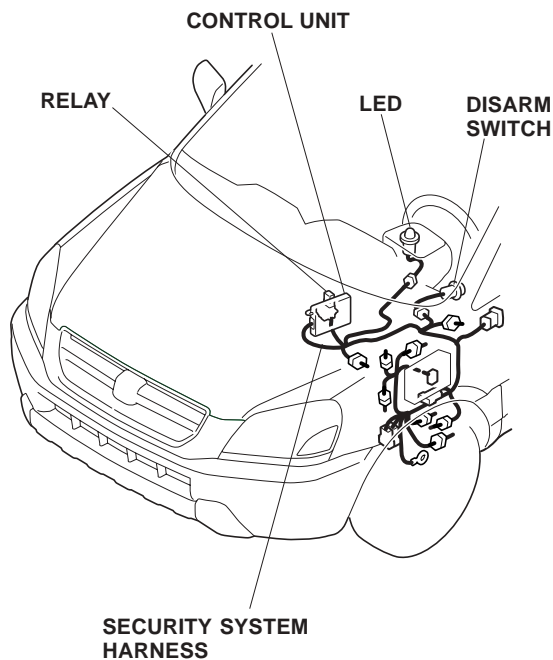

ADJUSTING THE CONTROL UNIT

- Use a small flat-tip screwdriver to change the mode switch and the horn/siren switch and to adjust sensitivity.

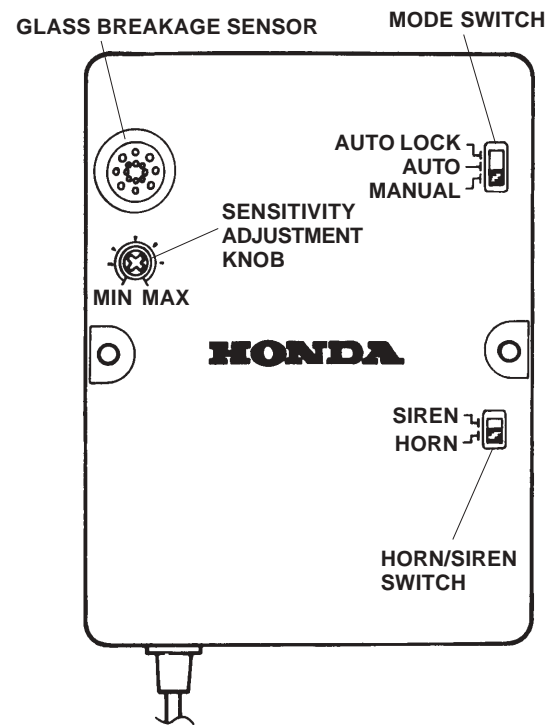

MODE SWITCH:

- Set the mode switch according to the customer's choice.
- Refer to the Owner's Manual for the explanation of each mode.

HORN/SIREN SWITCH:

- Set the switch to "HORN" in normal use. If an optional siren is installed, set the switch to "SIREN."

GLASS BREAKAGE SENSOR:

- Do not attach anything like Scotch tape over the holes; this is the microphone pick-up.

SENSITIVITY ADJUSTMENT KNOB:

- Adjust the sensitivity only if the customer requests it; the sensitivity adjustment of the glass breakage sensor is factory set.
- Be careful when you adjust the sensitivity; if you raise the sensitivity too much, the security system can give a false alarm, and if the sensitivity is too low, the security system may not work even if glass is broken.

INSTALLATION

Customer Information: The information in this installation instruction is intended for use only by skilled technicians who have the proper tools, equipment, and training to correctly and safely add equipment to your vehicle. These procedures should not be attempted by “do-it-yourselfers.”

1. Make sure you have the anti-theft code for the radio, then write down the frequencies for the preset buttons and the navigation code if the vehicle is equipped with a navigation system.
2. Disconnect the negative cable from the battery.
3. Remove the driver's dashboard lower cover (one self-tapping screw, three clips, and two hooks).

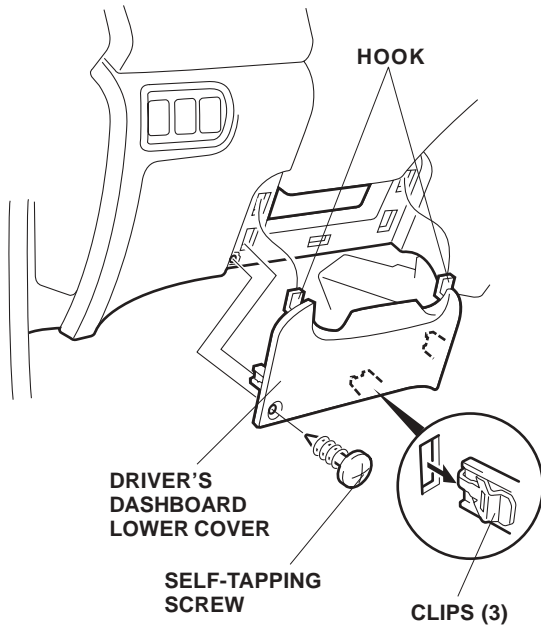

4. Lower the steering wheel using the tilt lever, then remove the upper and lower steering column covers (three self-tapping screws).
 - Carefully pry up on the seven retaining tabs to remove the lower steering column cover.
 - Insert the ignition key in the shift lock release hole, and move the shift lever to the “N” position while pressing down on the key.
 - Remove the key, then lift the upper steering column cover. Pull the cover out toward you, and remove it by lowering the shift lever to the “1” position.

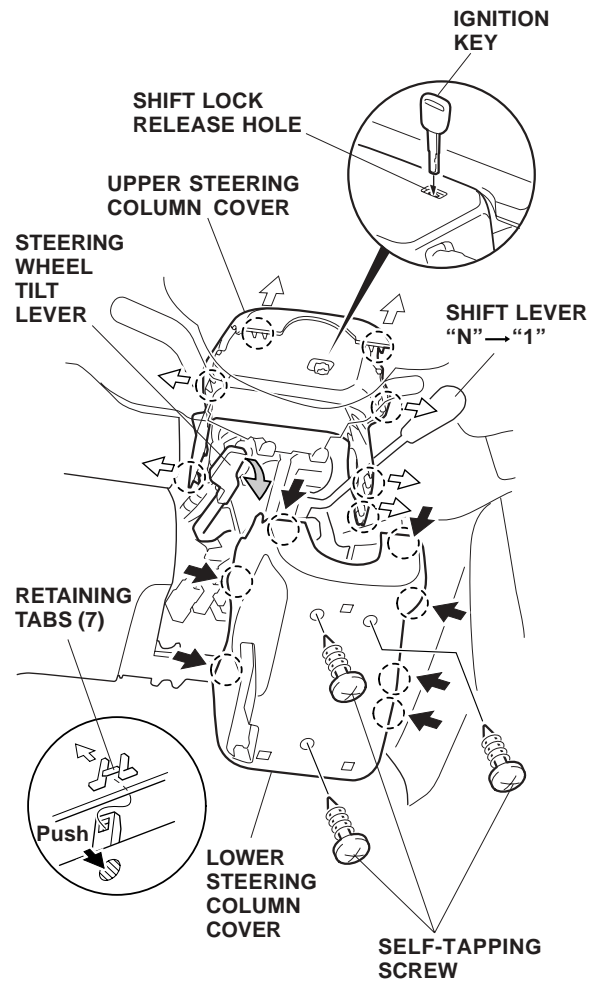

- Remove the switch trim (two clips and two retaining tabs), then unplug the interior light harness connector from the switch.

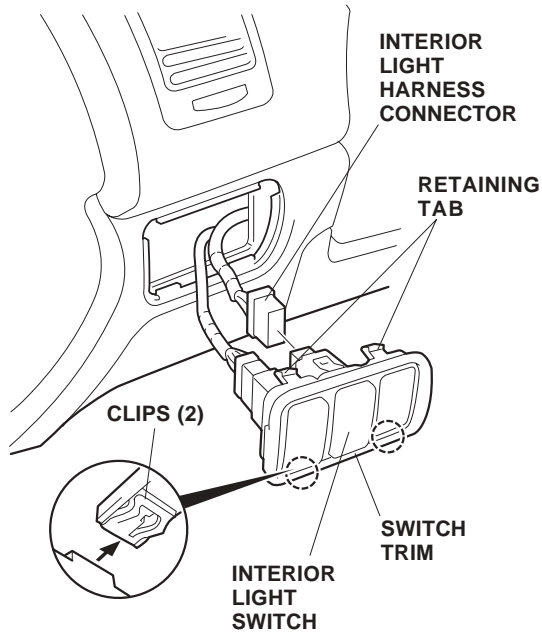

- Remove the fuel lid opener knob, then remove the left front trim (three clips and two retaining tabs).

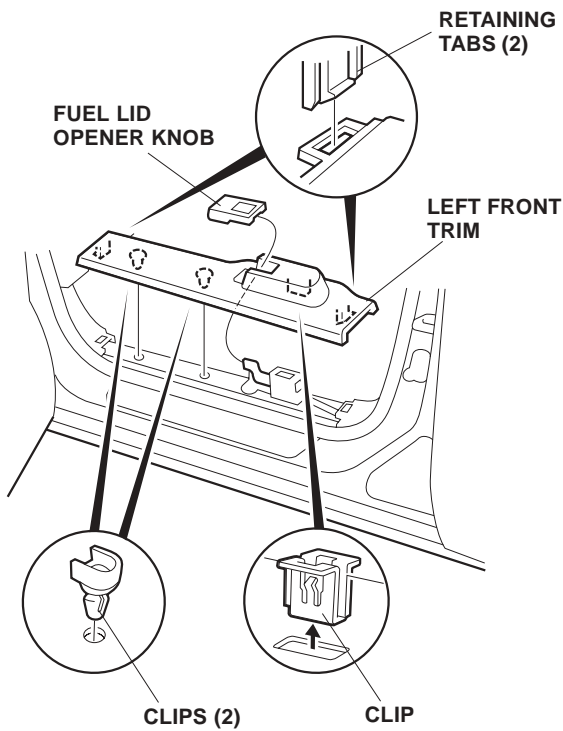

- Remove the weatherstrip from the left kick panel.

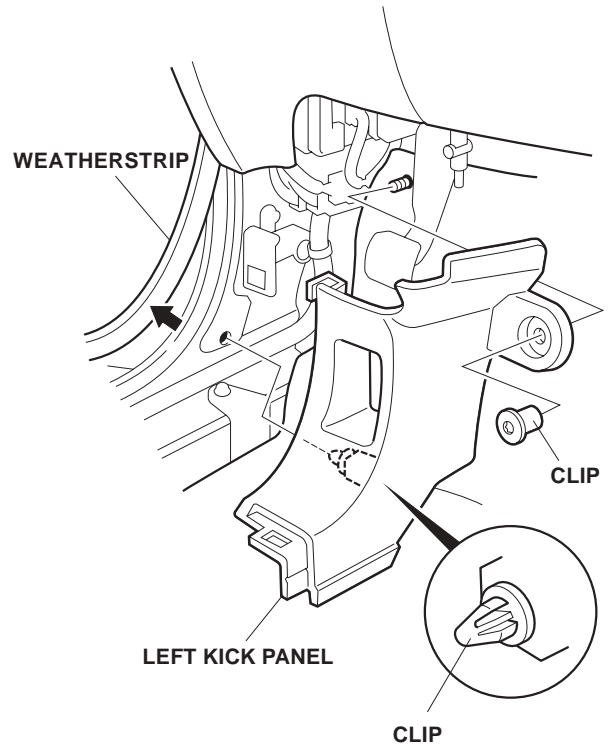

- Remove the upper clip from the left kick panel, then pull the left kick panel out toward you to release the remaining clip.

- Position the unit bracket on the control unit, and install the two 4 x 30 mm washer-screws and two flange nuts.

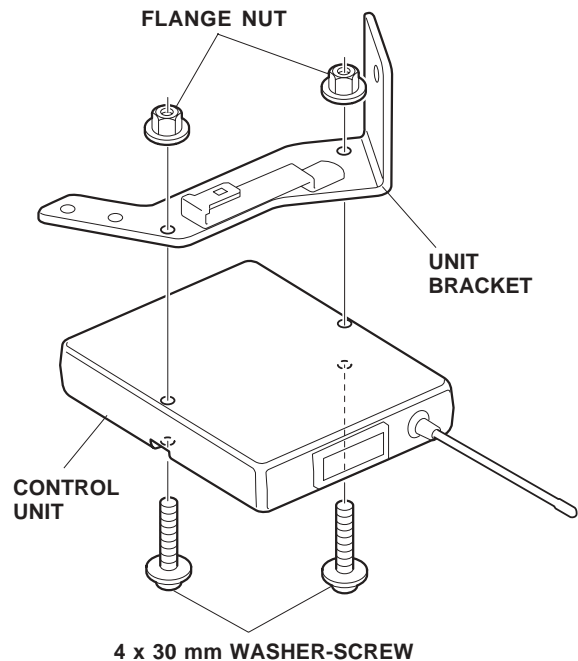

- Wrap one cushion tape around the antenna of the control unit, then pull the antenna out through the clearance between the unit bracket and the stay on the unit bracket as shown.

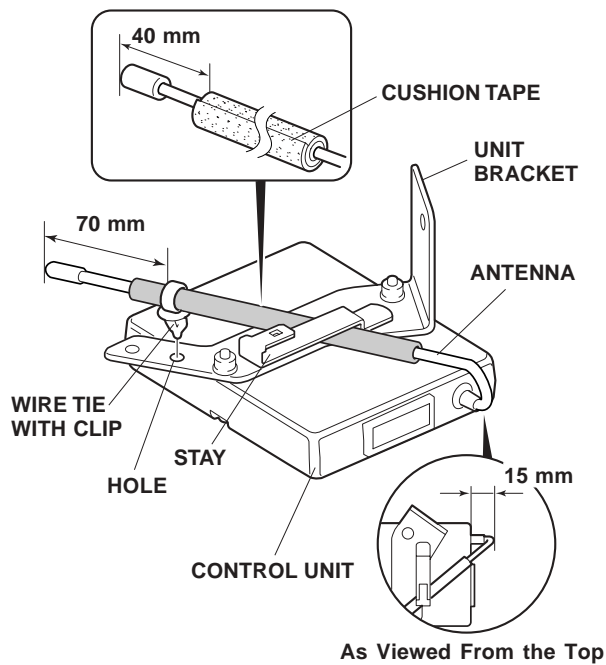

- Attach one wire tie with clip to the antenna, then push the clip of the wire tie into the hole in the unit bracket.
- Plug the relay into the relay block of the security system harness, then slide the relay block onto the stay on the unit bracket.

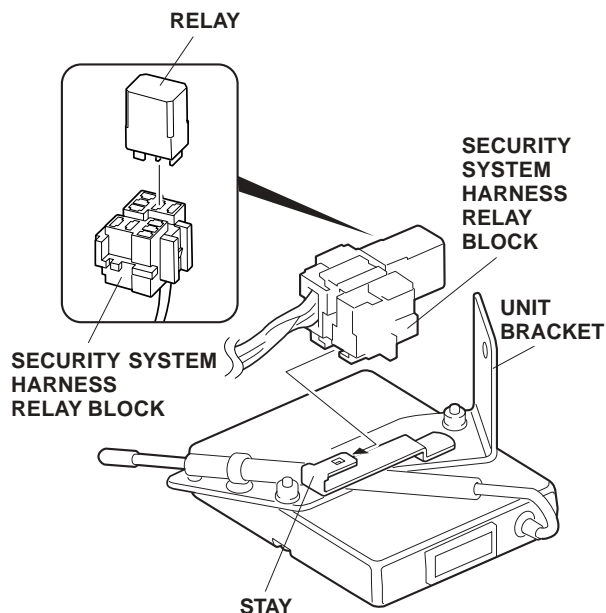

- Plug the 22-pin connector of the security system harness into the control unit.

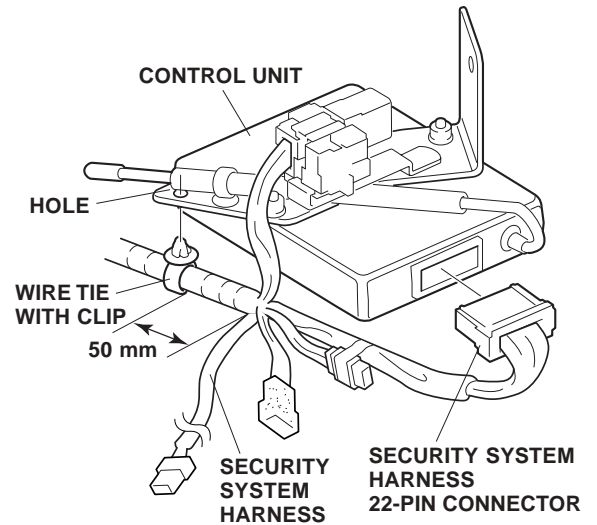

- Attach the other wire tie with clip to the security system harness, then push the clip of the wire tie into the hole in the unit bracket.
- Remove the bolt that secures the front of the steering hanger beam bracket, then attach the unit bracket with this bolt. Torque the bolt to 19 to 24 N·m (14 to 18 lb·ft).

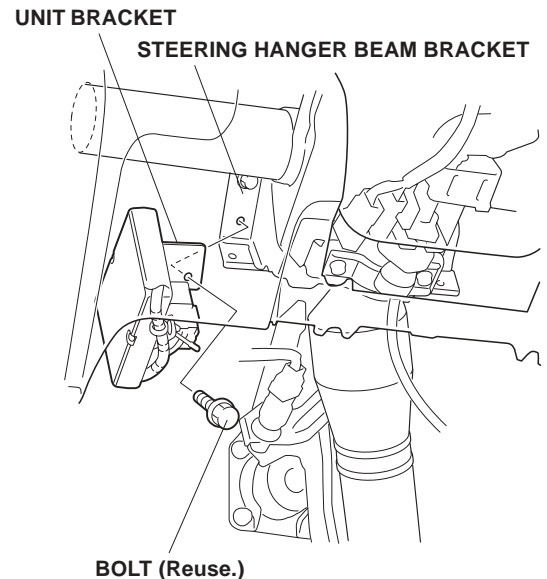

16. Above the parking brake pedal bracket, locate the 3-pin connector blue-taped to the vehicle harness, and remove the blue tape to free the connector. Plug the 3-pin connector of the security system harness into the 3-pin connector you just freed.

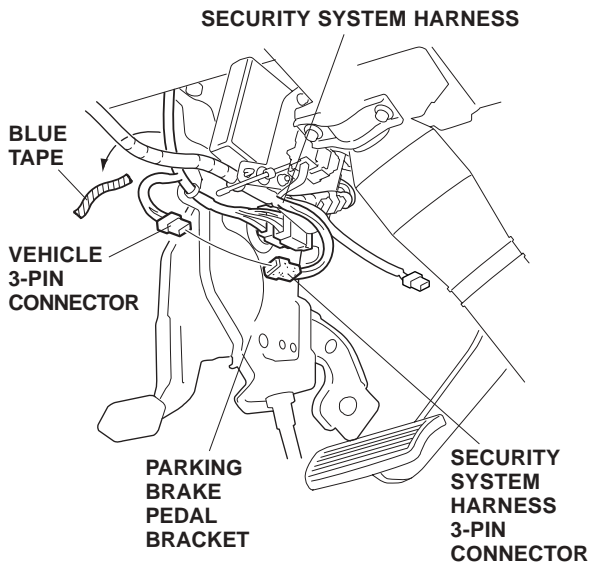

17. Route the 6-pin connectors of the security system harness to the switch trim opening. Plug the 6-pin connectors between the interior light switch and the interior light switch harness connector. Reinstall the switch trim.

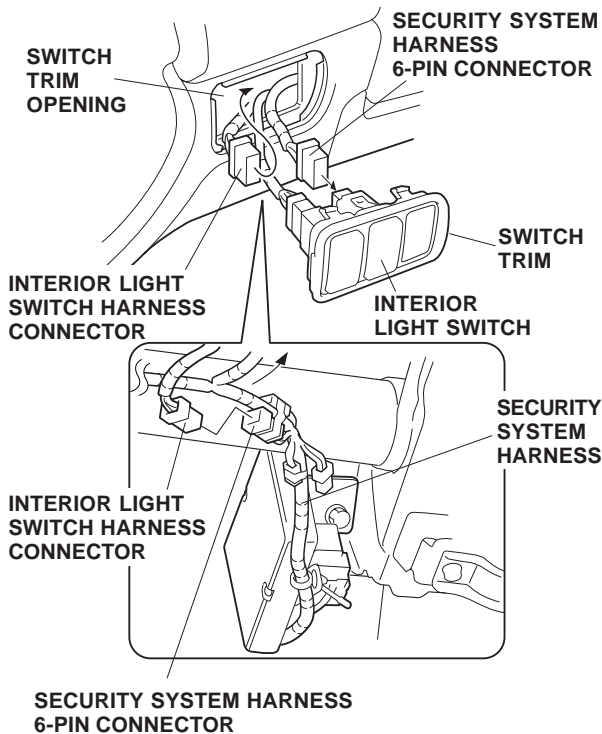

18. Unplug the vehicle 10-pin connector from the fuse box, and plug the two 10-pin connectors of the security system harness in between.

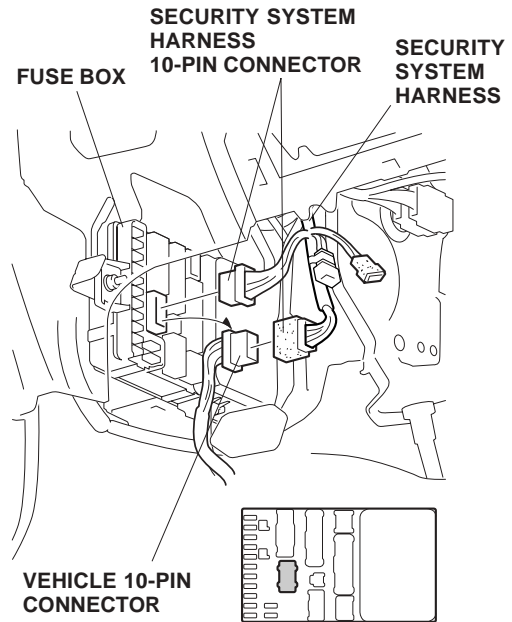

19. Above the fuse box, locate the gray 2-pin connector blue-taped to the vehicle harness. This connector is difficult to see, it is behind a gray 4-pin connector. Pull the gray 4-pin connector down and out of the clip on the instrument panel bracket. Remove the blue tape securing the gray 2-pin connector and pull it out.

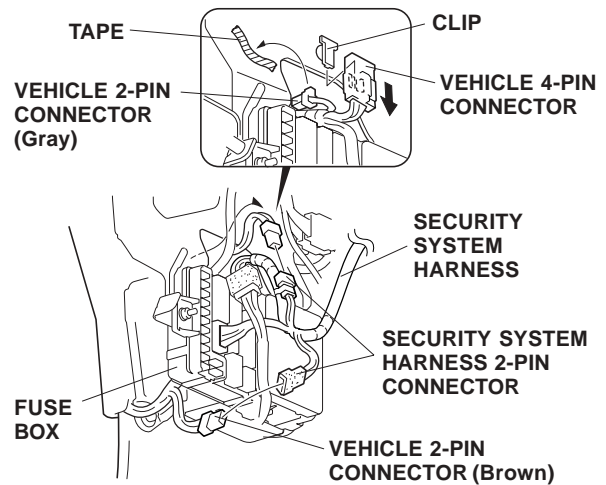

20. Below the fuse box, locate the brown 2-pin connector. Plug the security system harness 2-pin connectors into the brown connector and into the gray 2-pin connector from step 19. Reinstall the gray 4-pin connector.

- Open the fuse case covers, and check the rating of each fuse. Attach the fuse labels (OPTION 5 A/2 A) to the fuse cases on the security system harness.

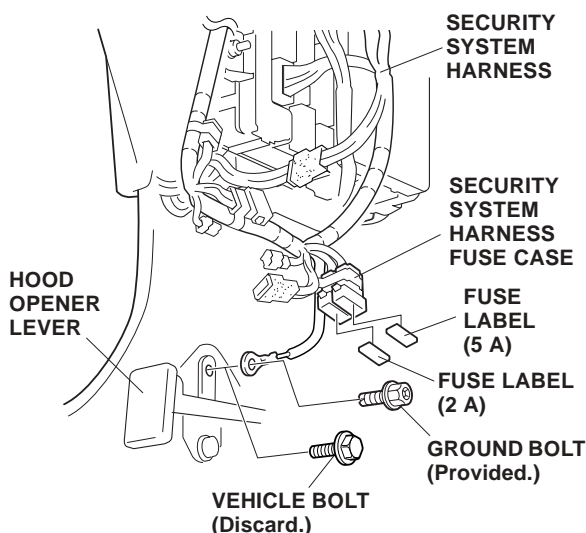

- Remove the bolt that secures the top of the hood opener lever, then attach the ground terminal of the security system harness with the ground bolt from the kit.
- Attach the fuse label (OPTION 2 A) to the fuse case on the security system harness.

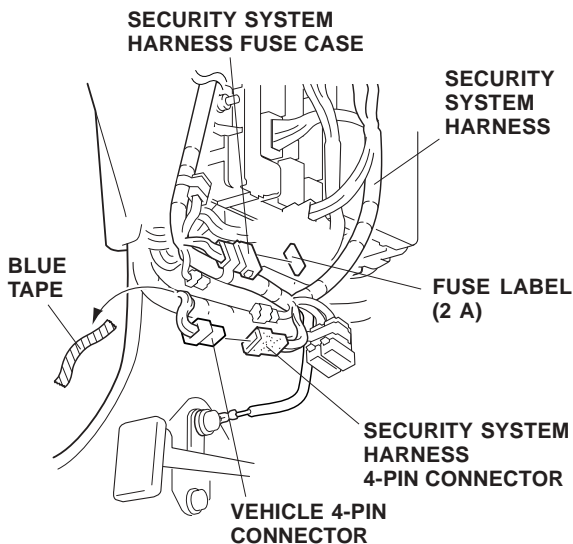

- Under the fuse box, locate the 4-pin connector blue-taped to the vehicle harness, and remove the blue tape to free the connector. Plug the 4-pin connector of the security system harness into the 4-pin connector you just freed.

- Under the fuse box, push in the vehicle 1-pin connector to remove it from the vehicle connector, then remove the tape securing the vehicle 1-pin connector. Unplug the vehicle 1-pin connectors, and plug the 1-pin connectors of the security system harness between the vehicle 1-pin connectors you just unplugged. Reinstall the vehicle 1-pin connector.

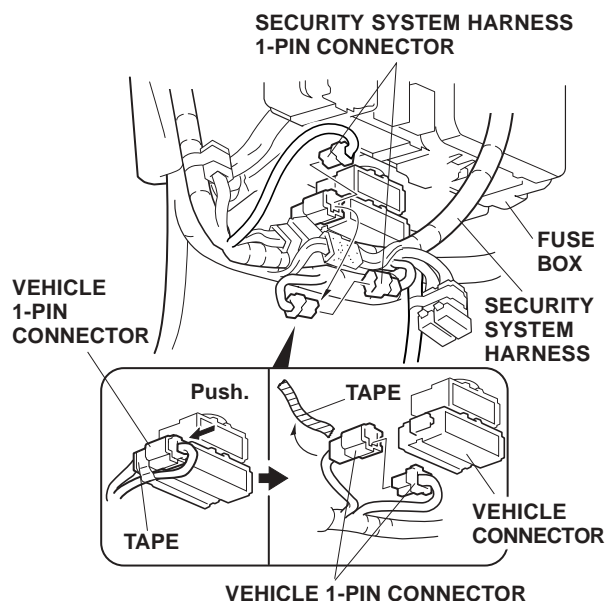

- Using isopropyl alcohol on a shop towel, thoroughly clean the instrument panel side frame bracket in the area shown. Cut one cushion tape into halves, and attach the two pieces to the side frame bracket as described.

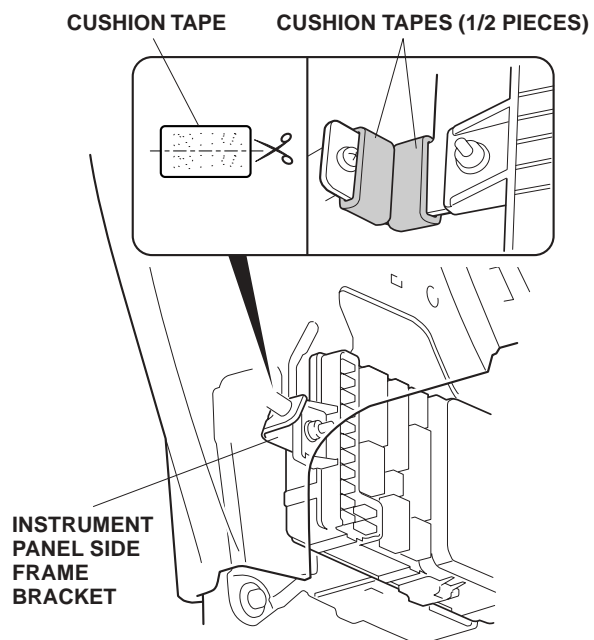

27. Secure the security system harness to the vehicle harness with three wire ties in the areas shown.

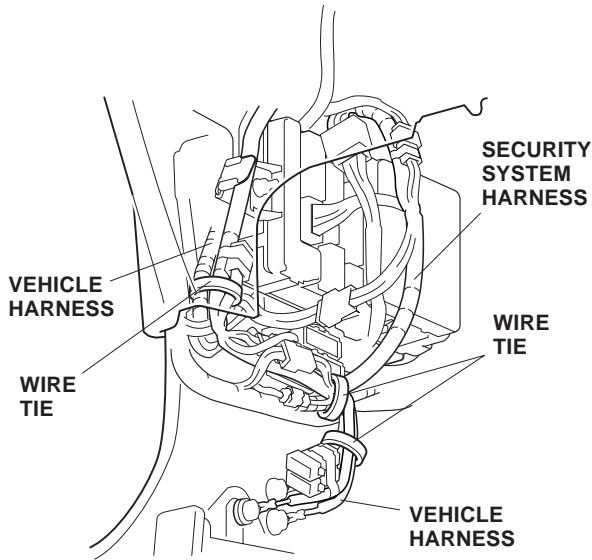

28. Further secure the security system harness to the instrument panel side frame bracket and the vehicle harness with four wire ties in the areas shown.

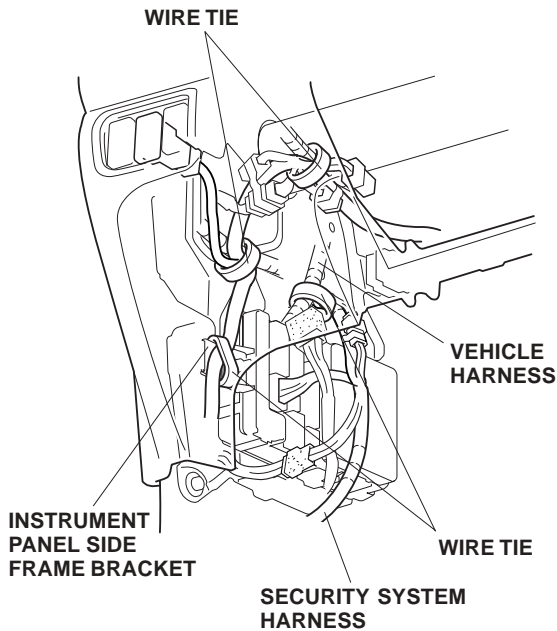

Installing the LED

29. Measure and mark the upper steering column cover.

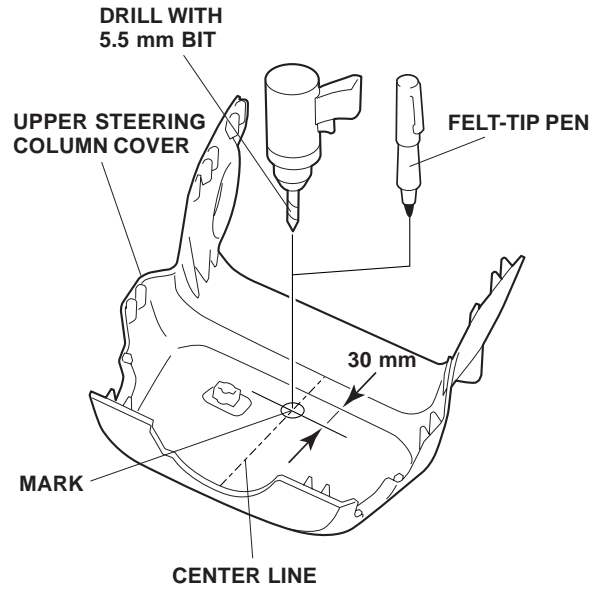

30. While wearing eye protection, lightly center-punch the mark; then drill a 5.5 mm hole through the upper steering column cover. Remove all burrs.
31. Route the terminal ends of the LED through the hole you just drilled, and secure the LED with the push nut. Install the push nut securely.

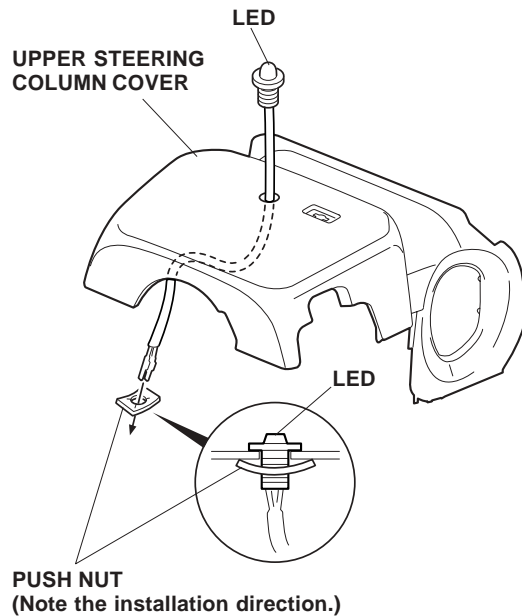

32. Using isopropyl alcohol, thoroughly clean the back of the upper steering column cover in the area shown. Secure the LED harness to the upper steering column cover with 1/2 of a cushion tape.

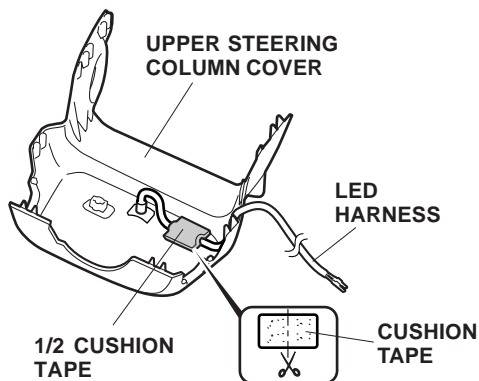

33. Get the 2-pin connector included in the kit. Firmly push the LED terminals into the 2-pin connector until they click into position, then lower the lock.

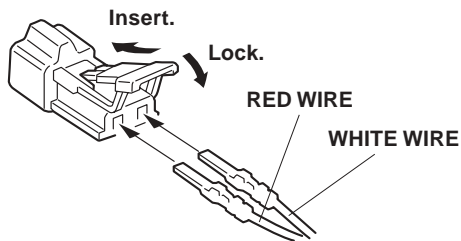

Installing the Disarm Switch

34. Measure and mark the driver's dashboard lower cover.

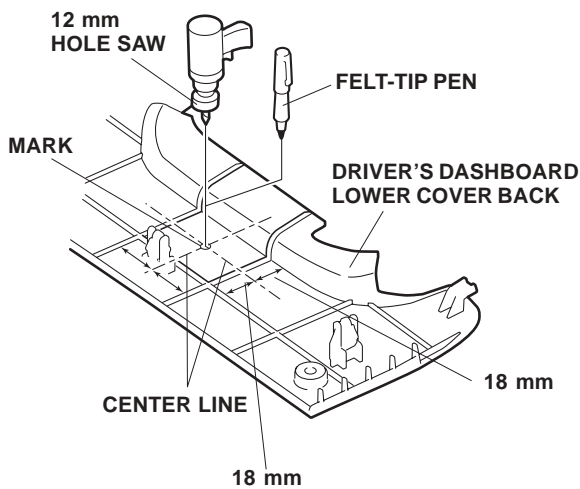

35. While wearing eye protection, lightly center-punch the mark; then drill a 12 mm hole through the center-punched mark. Remove all burrs.

36. Route the terminal ends of the disarm switch through the hole you just drilled, and secure it with the washer and 12 mm nut from the kit.

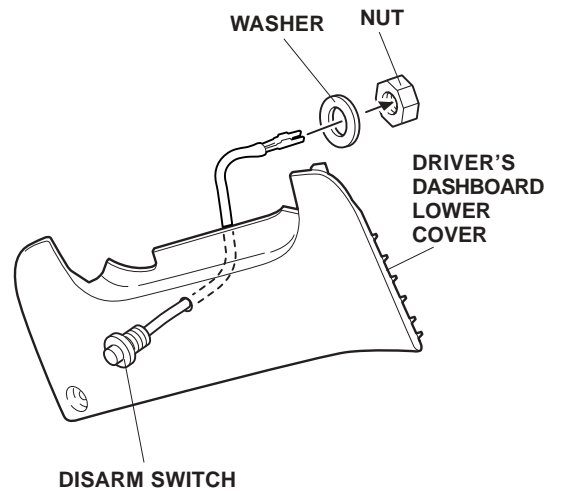

37. Get the 3-pin connector included in the kit. Firmly push the disarm switch's terminals into the 3-pin connector until they click into position, then lower the lock.

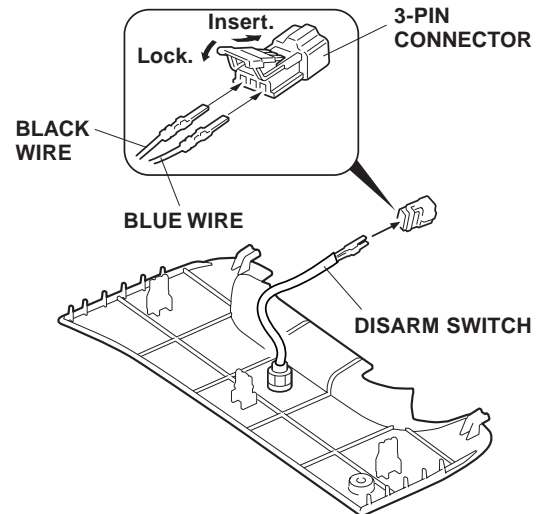

- Position the upper steering column cover on the steering column, then plug the 2-pin connector connected to the LED harness to the 2-pin connector of the security system harness.

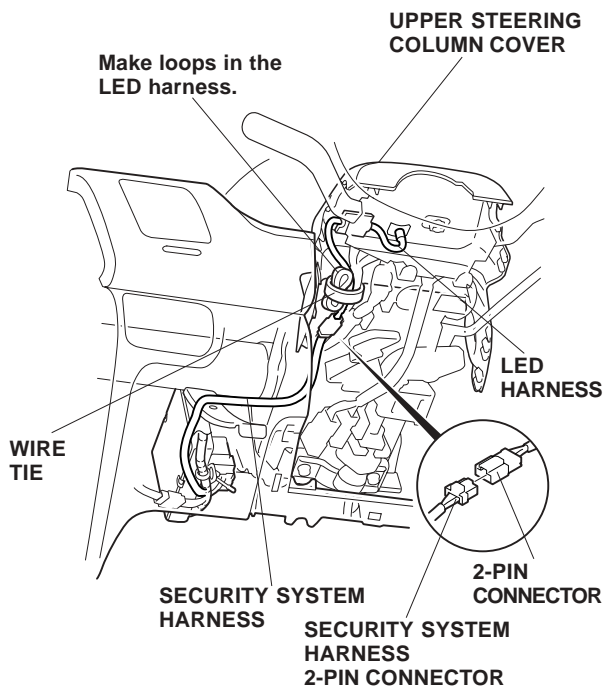

- Make loops in the LED harness, and secure them to the vehicle harness with one wire tie as shown.
- Plug the 3-pin connector connected to the disarm switch into the 3-pin connector of the security system harness, then reinstall the driver's dashboard lower cover.

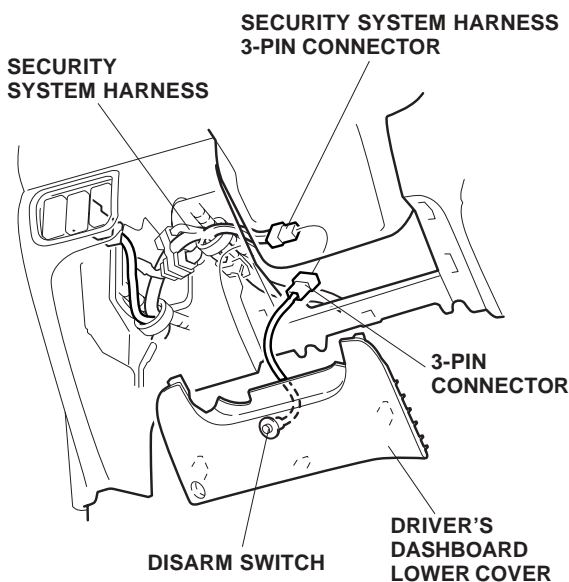

- Secure the security system harness and the disarm switch harness to the vehicle harness with three wire ties in the areas shown.

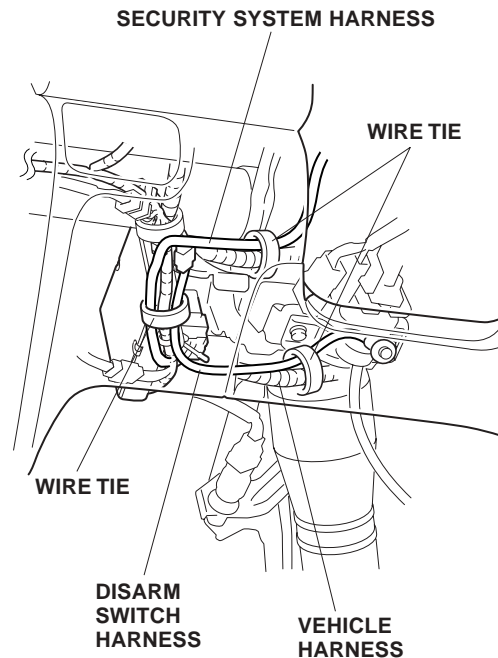

- Check that all wire harnesses and cables are routed properly and all connectors are plugged in.
 - Reinstall all removed parts.
 - Reconnect the negative cable to the battery.
 - Enter the customer's radio anti-theft code, navigation code if applicable, and reset the radio station presets.
 - Set the clock.
 - Check operation of the security system according to the Owner's Manual supplied.
- NOTE:** Whenever the battery is disconnected, the driver's window AUTO function is disabled.
- Start the engine. Push down on the driver's window switch until the window is fully open.
 - Pull up on the driver's window switch to close the window completely, then hold the switch for two seconds.
 - Lower and raise the driver's window to check operation of the driver's window AUTO function.

51. Do the PCM idle learn procedure.

- Make sure all electrical items are turned off.
- Start the engine. Hold the engine speed at 3,000 rpm with no load (in Park or Neutral) until the radiator fan comes on.
- Let the engine idle for about 5 minutes with the throttle fully closed and with all electrical items off.

NOTE: If the radiator fan comes on during this step, the time when it is operating must not be included in the 5 minutes.