



# INSTALLATION INSTRUCTIONS

Accessory	Application	Publications No.
FOG LIGHT KIT (WITH LOWER TRIM)	PILOT	All 23612
		Issue Date MAY 2002

## Fog Light Kit P/N 08V31-S9V-110A

Right fog light

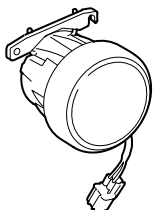

Left fog light

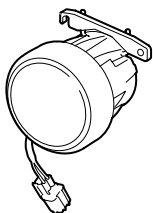

Right fog light bracket

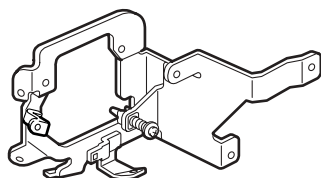

Left fog light bracket

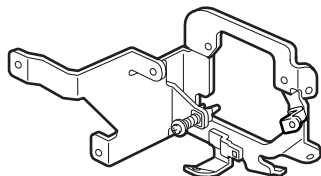

Switch harness

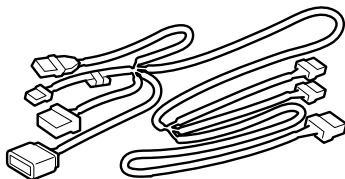

Fog light harness

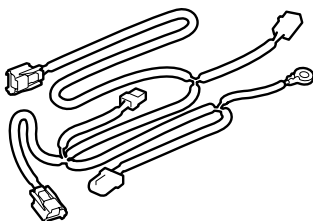

Switch

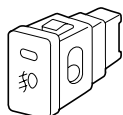

4 Collars



Relay with rubber

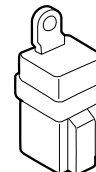

Relay

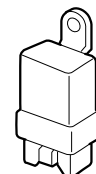

27 Wire ties

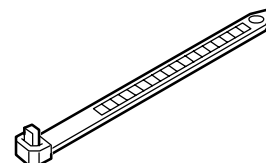

8 Washer-screws, 5 x 16 mm



4 Washer-screws, 4 x 12 mm



Fuse label A

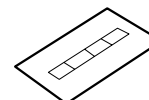

3 Washer-bolts



3 Flange nuts



Unit bracket

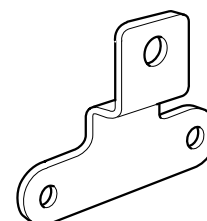

Fusible link

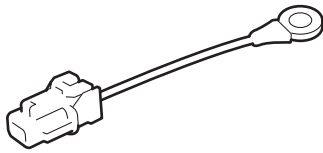

Nut



2 Wire ties with holder

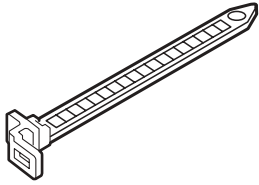

Control unit bracket



Right fog light cover

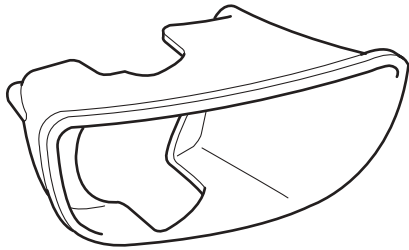

Left fog light cover

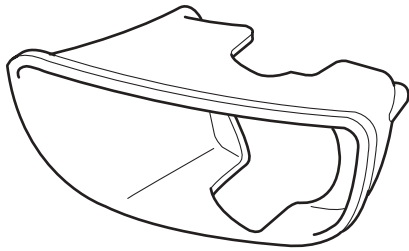

4 Self-tapping screws, 5 x 20 mm



Fuse label B

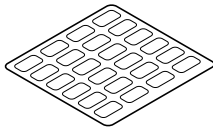

2 Washers



## TOOLS AND SUPPLIES REQUIRED

Phillips screwdriver

Flat-tip screwdriver

Ratchet

10 mm and 12 mm Sockets

Diagonal cutters

40 mm Hole saw

Utility knife

Hacksaw blade

10 mm Combination wrench

Cardboard or blanket

Drill

3 mm and 9 mm Drill bits

Torque wrench

Pushpin

File

Ruler

Felt-tip pen

Clip remover

## Illustration of Fog Lights Installed on the Vehicle

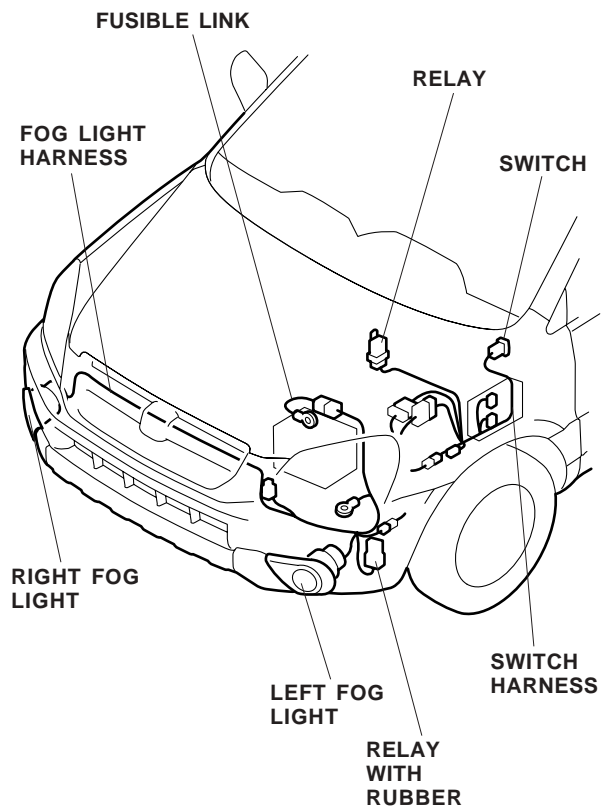

## INSTALLATION

**Customer Information:** The information in this installation instruction is intended for use only by skilled technicians who have the proper tools, equipment, and training to correctly and safely add equipment to your vehicle. These procedures should not be attempted by “do-it-yourselfers.”

1. Make sure you have the anti-theft code for the radio, then write down the frequencies for the preset buttons.
2. Disconnect the negative cable from the battery.

### Routing the Fog Light Harness

3. Open the hood. Remove the bulkhead cover (11 clips).

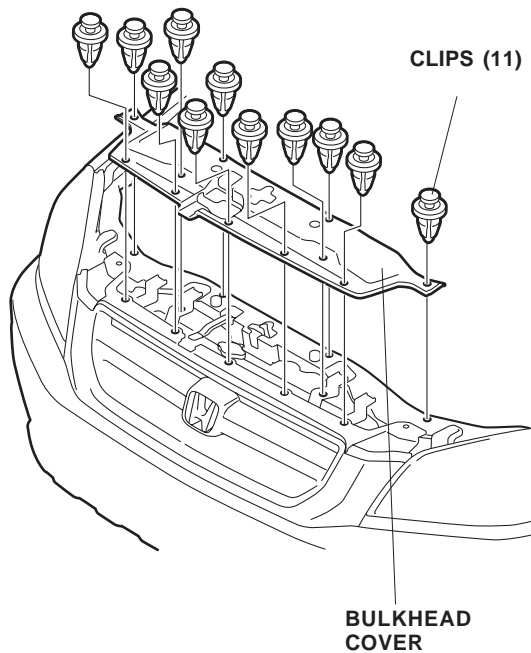

4. Remove the front bumper (two short clips, two self-tapping screws, four bolts, and two long clips).

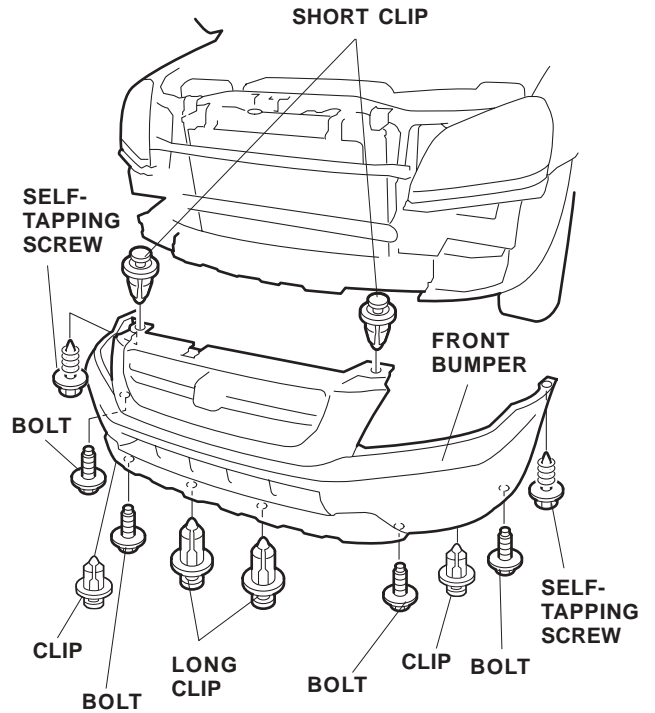

5. Remove the wire cable clip and the tube from the air cleaner case.

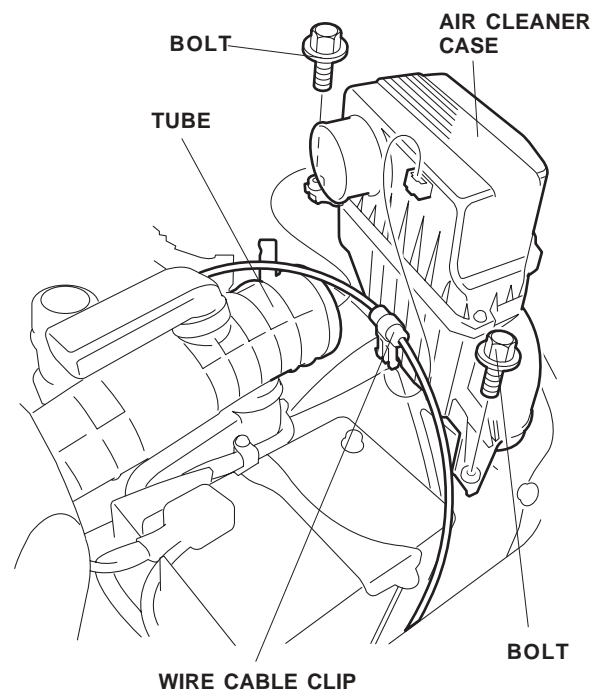

6. Remove the air cleaner case (2 bolts) and remove the air cleaner assembly. Be careful to avoid damaging the vehicle harness.

- Lift the cover on the positive battery cable, and route the terminal end of the fusible link through the cover.

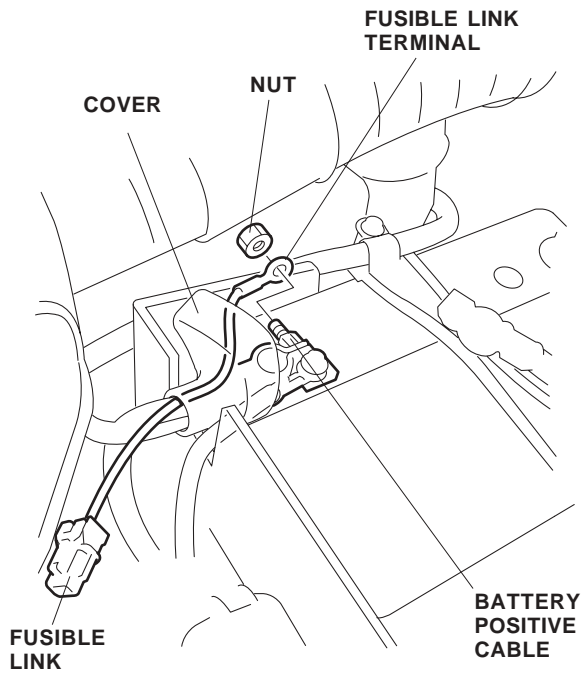

- Attach the terminal of the fusible link to the positive cable of the battery with the nut provided. Secure the positive cable.

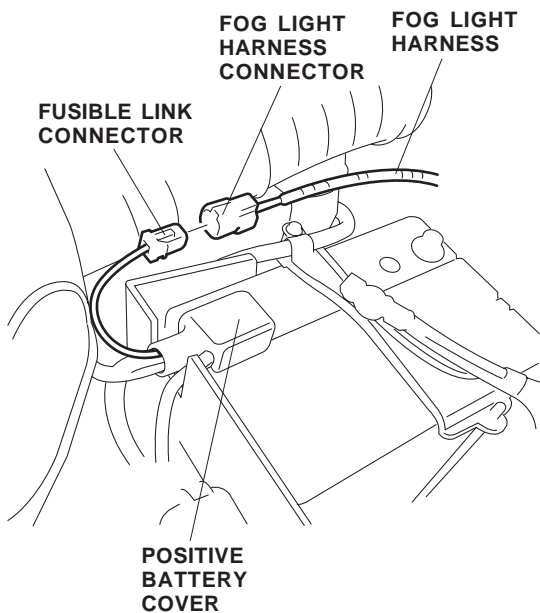

- Reinstall the cover on the positive battery cable. Get the fog light harness. Plug the fusible link connector into the fog light harness connector.

- Route the fog light harness between the vehicle harness and the body panel alongside the vehicle harness and under the left headlight.

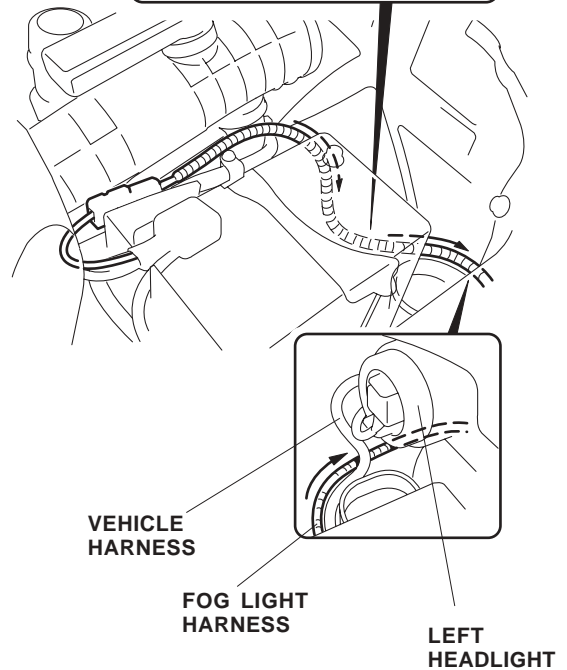
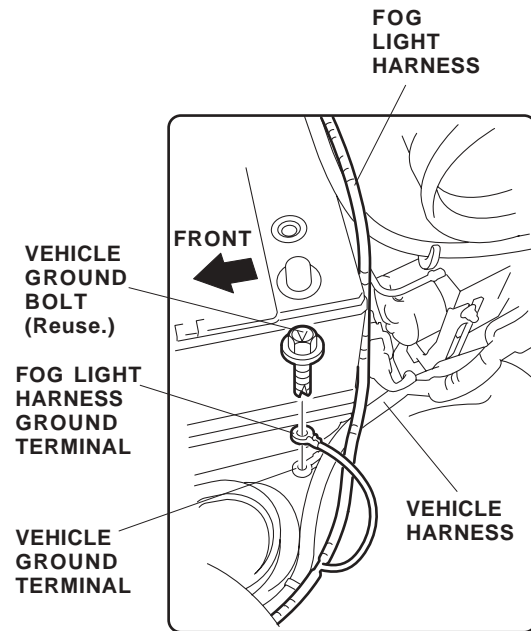

- Remove the vehicle ground bolt, and secure the fog light harness ground terminal using the ground bolt.
- Pull the fog light harness out from under the left headlight.

- On the left front bulkhead, locate the 1-pin connector blue-taped to the vehicle harness. Remove the blue tape to free the connector. Plug the 1-pin connector you just freed into the 1-pin connector of the fog light harness.

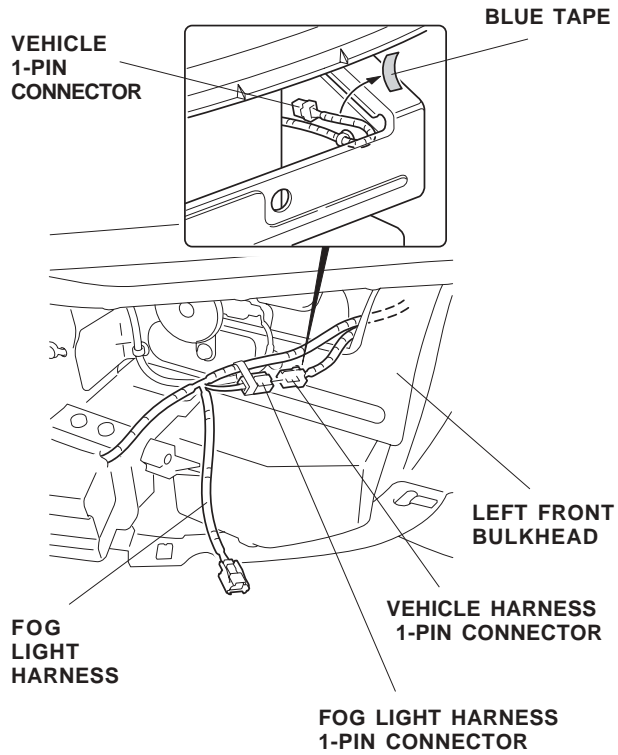

- Position the relay with rubber on the unit bracket, and install them with a flange nut and a washer-bolt.

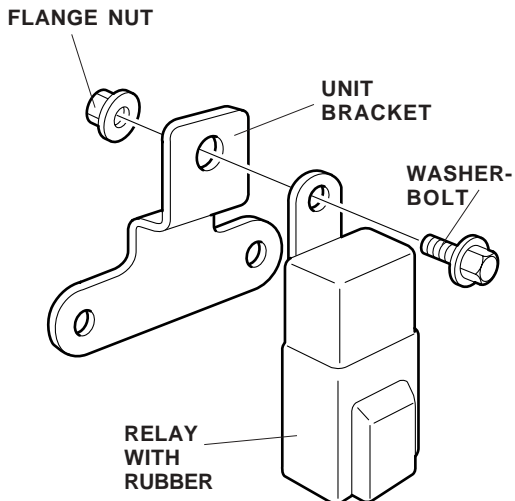

- Route the long end of the fog light harness 2-pin connector under the left horn and into the engine compartment.

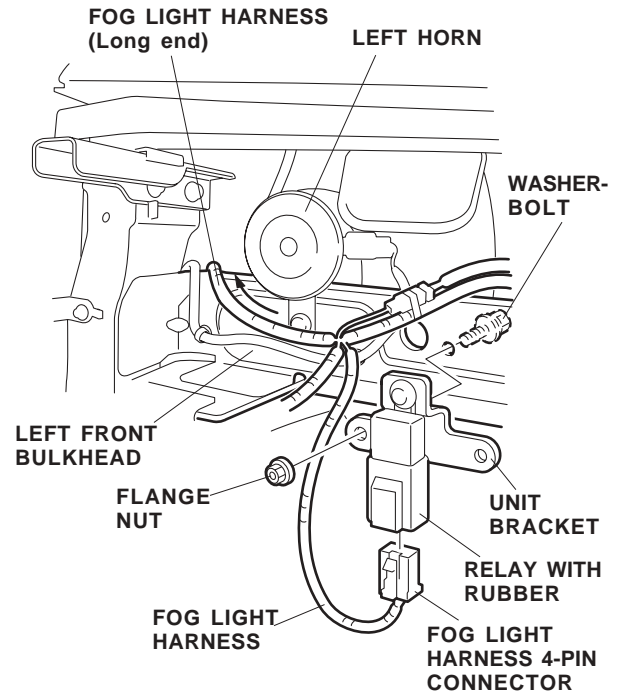

- Attach the unit bracket to the left front bulkhead with a flange nut and a washer-bolt.
- Plug the fog light harness 4-pin connector into the relay with rubber.

18. Route the fog light harness alongside the vehicle harness and above the fan shroud toward the right (passenger's) side of the vehicle.

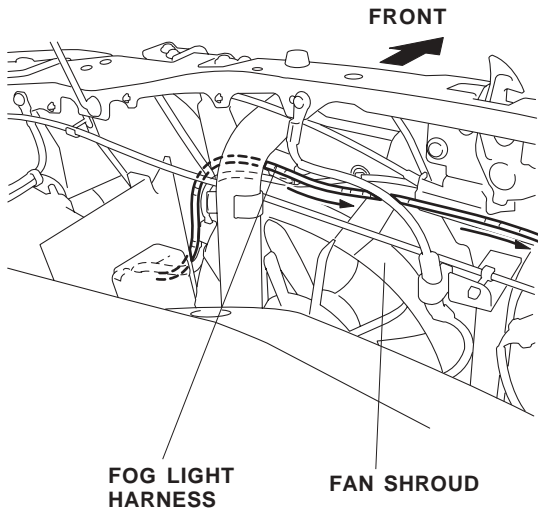

19. Continue routing the fog light harness under the vehicle harness to the right side of the vehicle, then pull the harness out from under the right headlight through the opening near the right horn.

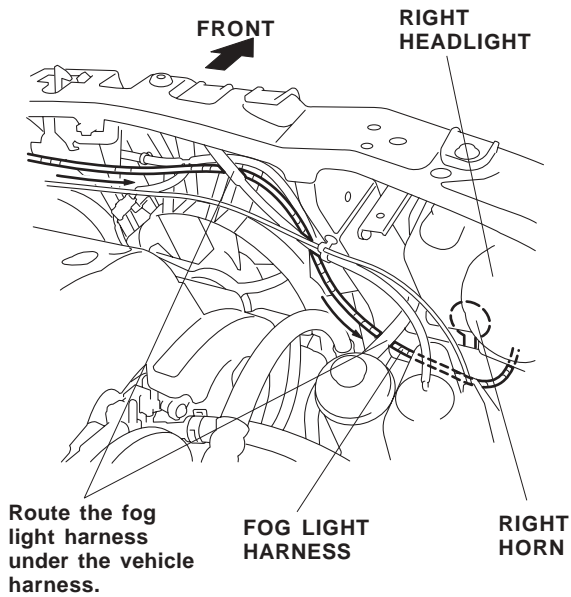

Route the fog light harness under the vehicle harness.

20. Clip the wire tie with holder onto the fog light harness connector, and attach this wire tie to the vehicle harness.

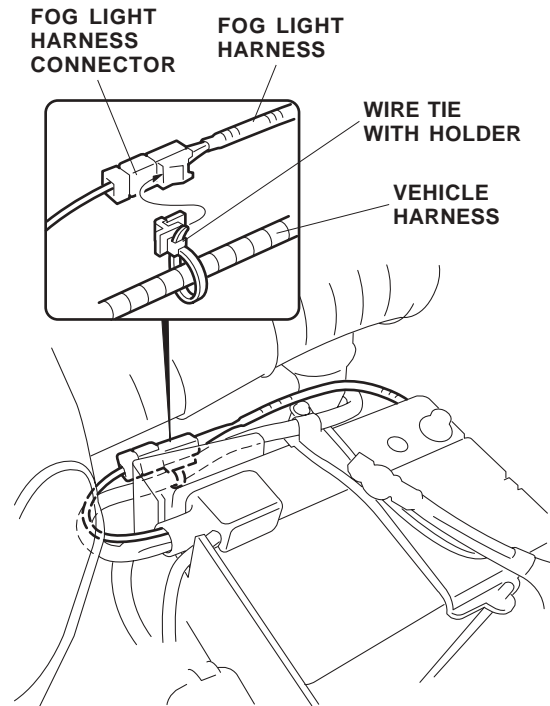

21. Near the battery, secure the fog light harness to the vehicle harness with three wire ties in the areas shown.

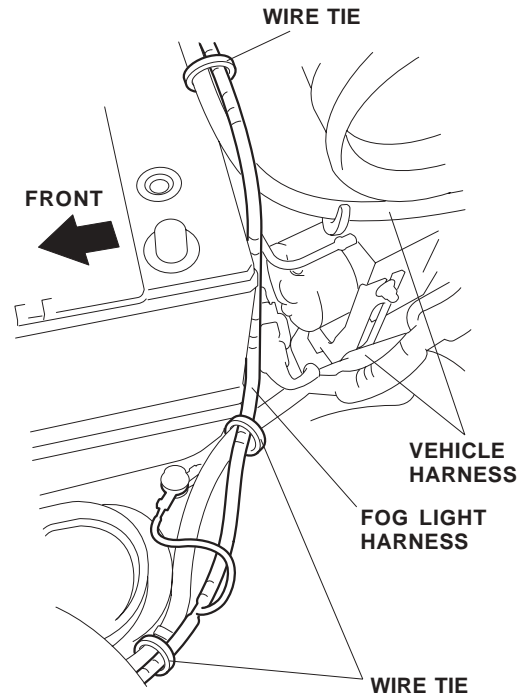

22. At the 1-pin connector, secure the fog light harness to the vehicle harness with three wire ties in the areas shown.

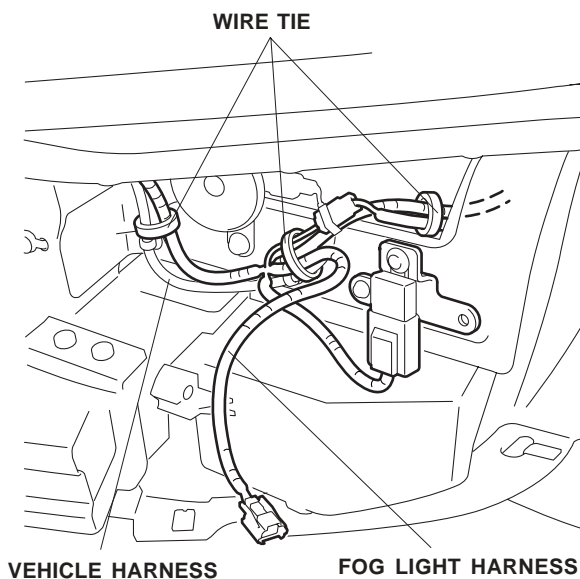

23. Secure the fog light harness to the vehicle harness with the four wire ties.

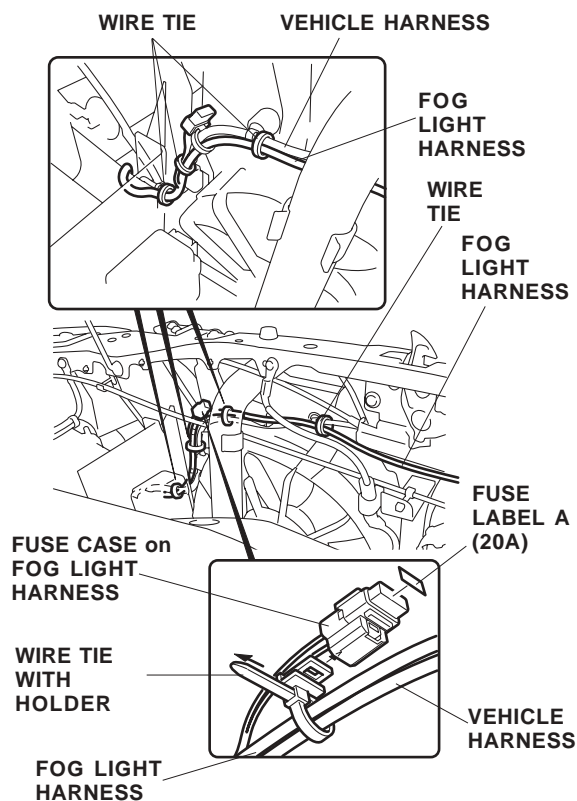

24. Attach the fuse label A (FOG LIGHT 20A) to the fuse case on the fog light harness.
25. Slide the holder of the wire tie with holder onto the fuse case of the fog light harness, then attach this wire tie with holder to the vehicle harness and the fog light harness as shown.

26. Above the fan shroud, secure the fog light harness to the vehicle harness with five wire ties.

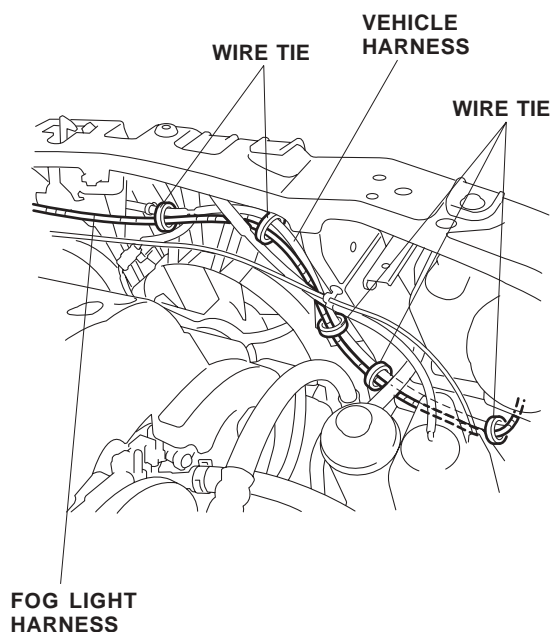

27. Below the right headlight, secure the fog light harness to the vehicle harness with two wire ties.

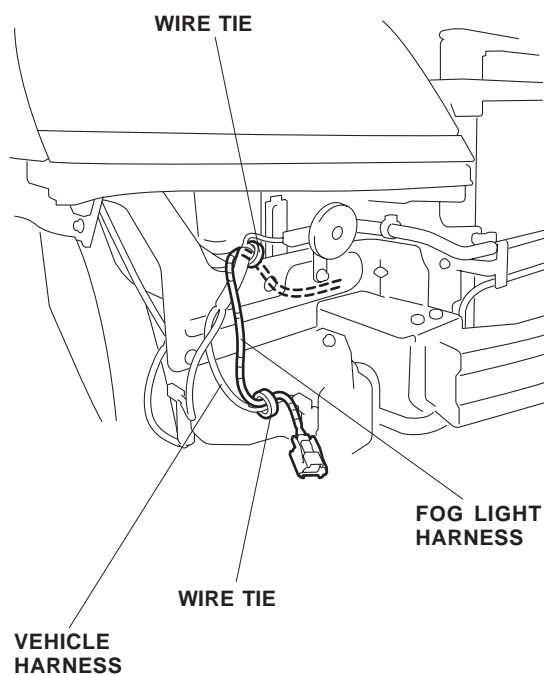

## Installing the Fog Lights

28. If equipped, remove the front bumper lower trim. If you are going to install a front bumper lower trim, refer to the front bumper lower trim installation instructions before drilling the front bumper.

Check on the inside of the front bumper for reference marks, if there are no reference marks, continue with step 29: otherwise, go to step 35.

29. Make a copy of the left and right side templates (last two pages). Using scissors, cut out the left template along the outer edge.

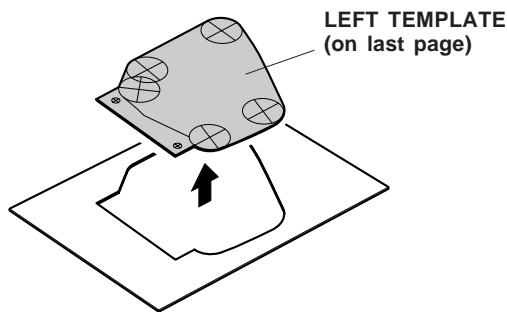

30. On the inside of the front bumper, locate the two marks scribed into the bumper. Using a pushpin, pierce through the bumper at the two marks.

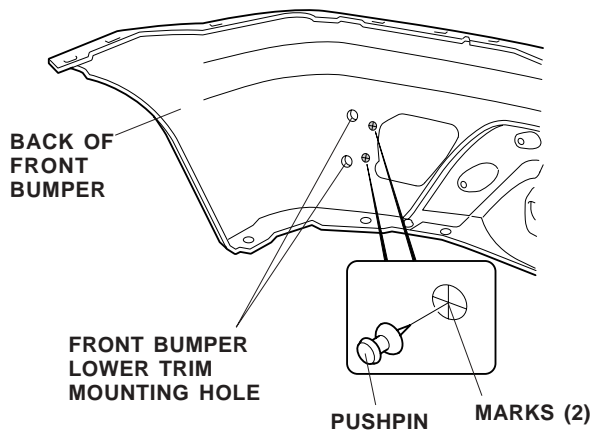

31. Position the left template on the inside of the front bumper, and align the two outer marks of the template with the two holes you made in the bumper. Align the other end of the template with the scribed line on the front bumper. Use strips of tape and two pushpins to hold the template in place.

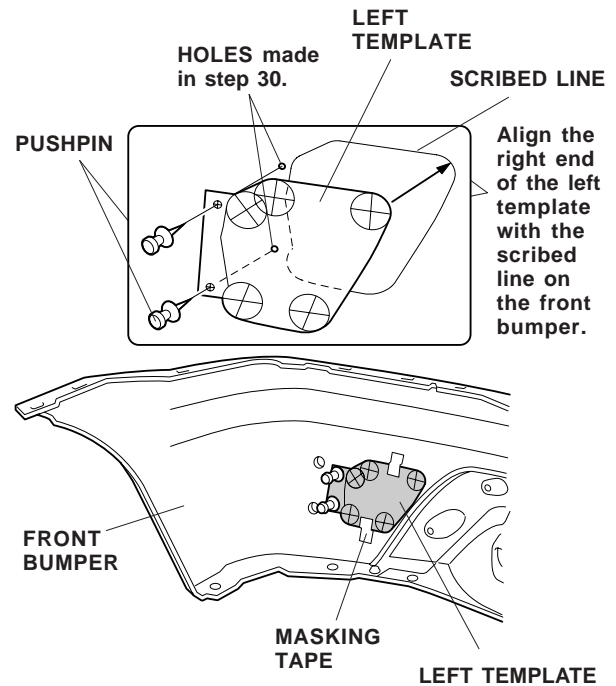

32. Using a pushpin, pierce through the bumper at the remaining 5 places on the template.

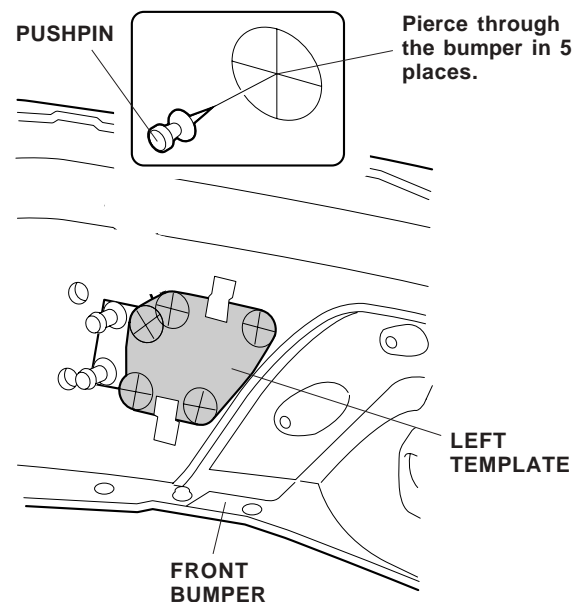

33. Get the right template and repeat steps 30 thru 32 to mark the right side side of the front bumper, then go to step 34.

34. On the inside of the front bumper, locate the seven marks scribed into the bumper. Use a pushpin to make holes through the front bumper at each of the seven marks.

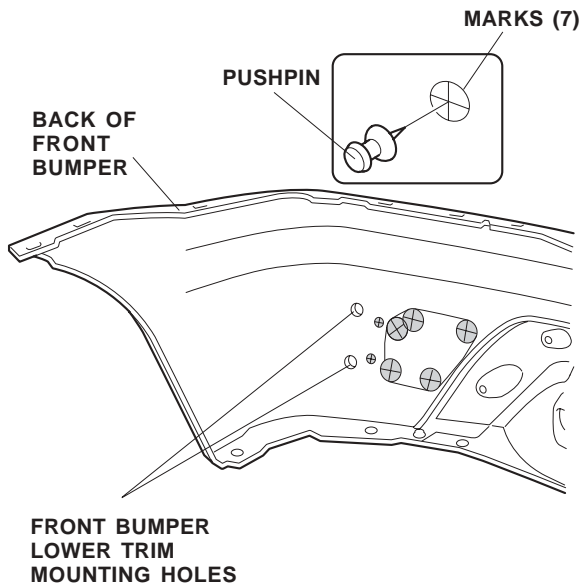

35. While wearing eye protection, drill a 9 mm through each of the two outboard marks you made. Drill from the outer surface inward, first with a 3 mm drill bit, and finish with a 9 mm drill bit. Remove any burrs from the edges of the holes with a file.

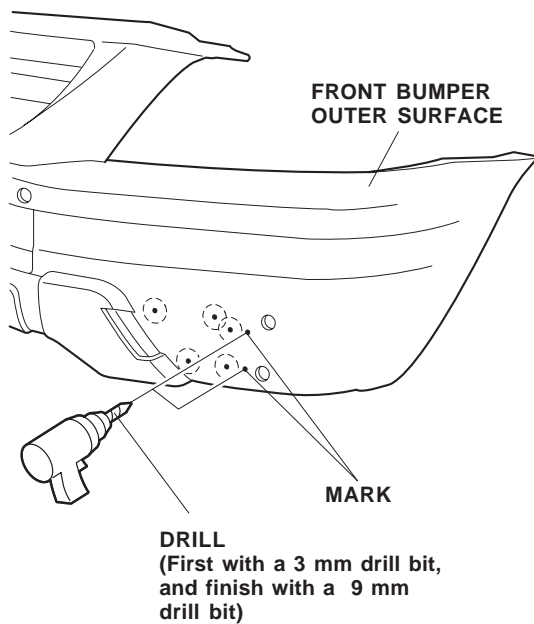

36. Using a 40 mm hole saw, drill through each of the remaining five marks of the front bumper.

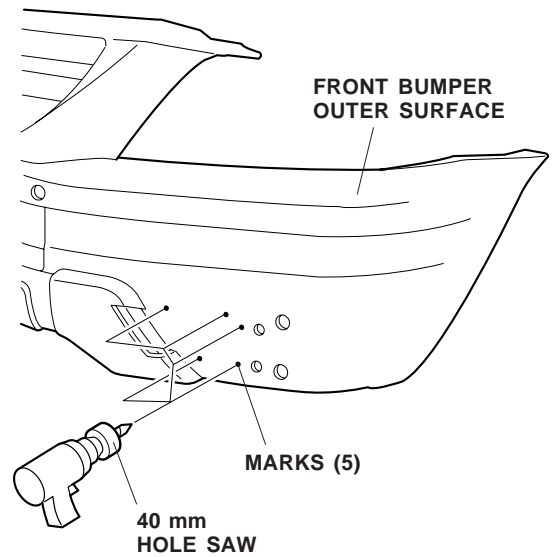

37. On the inside of the front bumper, use a ruler and felt-tip pen to make a line between the corners of the five holes. Using a hacksaw blade, cut out the marked area from the front bumper along the lines. Remove any burrs from the edge of the holes.

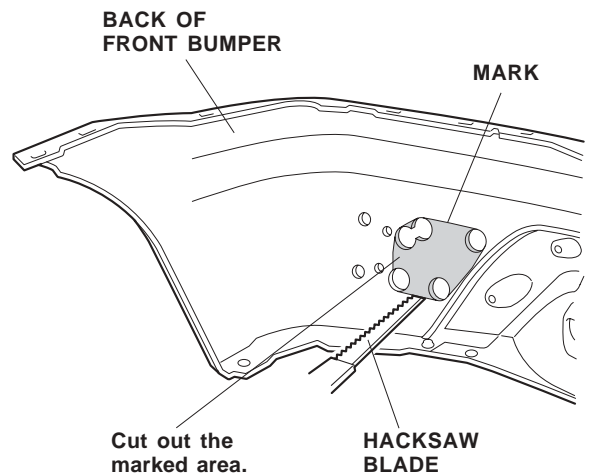

38. Get the left fog light and the left fog light bracket. Insert the slot of the left fog light into the aiming adjusting screw, then install the two 5 x 16 mm washer-screws. Position the connector near the connector stay.

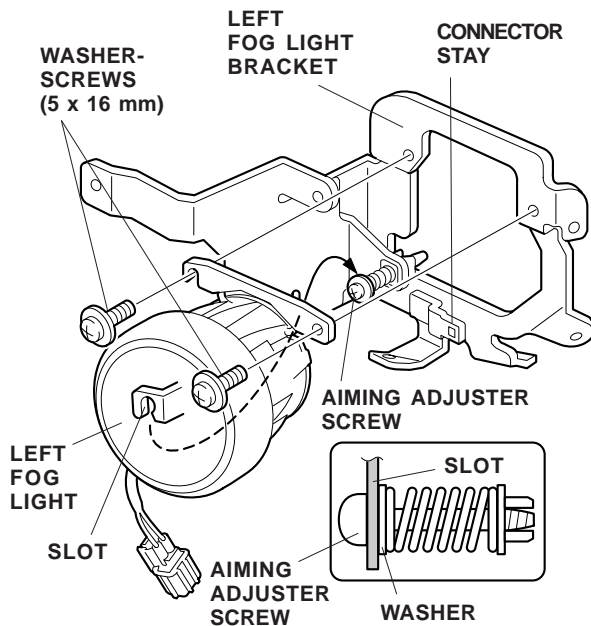

39. On the inside of the front bumper near the hole you cut, remove and discard the two self-tapping screws from the bumper. Position the left fog light bracket on the left mounting bosses, and reinstall the two 5 x 20 mm self-tapping screws and the washer.

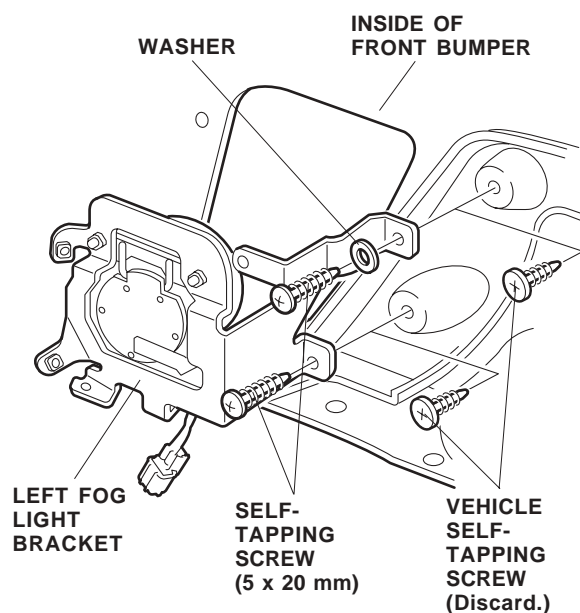

40. Install the left fog light bracket on the front bumper with the two 5 x 16 mm washer-screws and two collars from the outside.

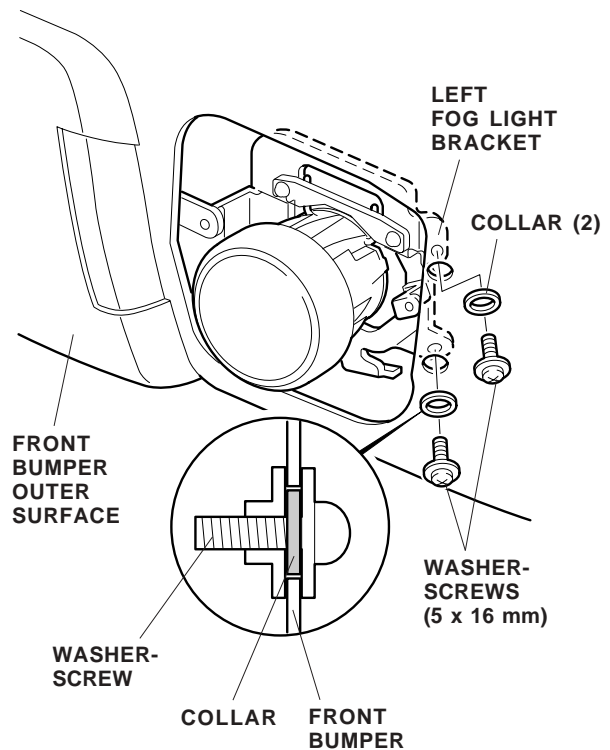

41. Repeat steps 35 thru 40 to install the right fog light onto the right fog light bracket at the right side of the front bumper.
42. Reinstall the front bumper lower trim, or refer to the front bumper lower trim installation instructions to install the front bumper lower trim.

43. While holding the front bumper close to the vehicle, connect the 2-pin connectors of the fog light harness to the right and left fog lights, then reinstall the front bumper. Make sure that all clips and retaining tabs are installed securely.

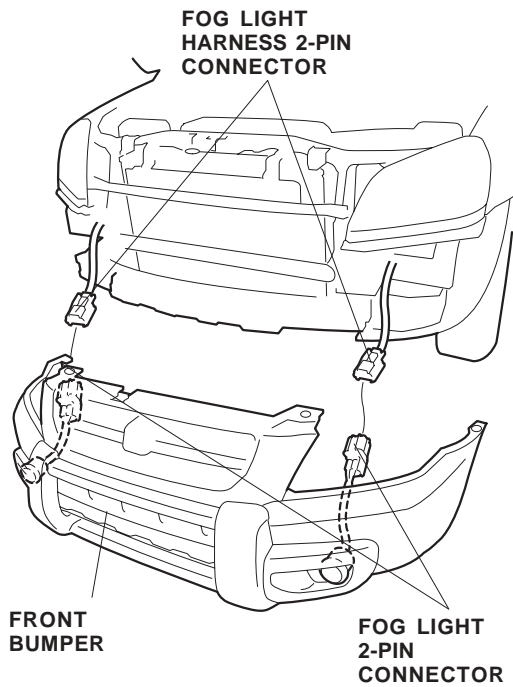

44. Pull the 2-pin connectors out from between the fog light brackets, and slide the 2-pin connectors from the fog lights onto the stays of the fog light brackets.

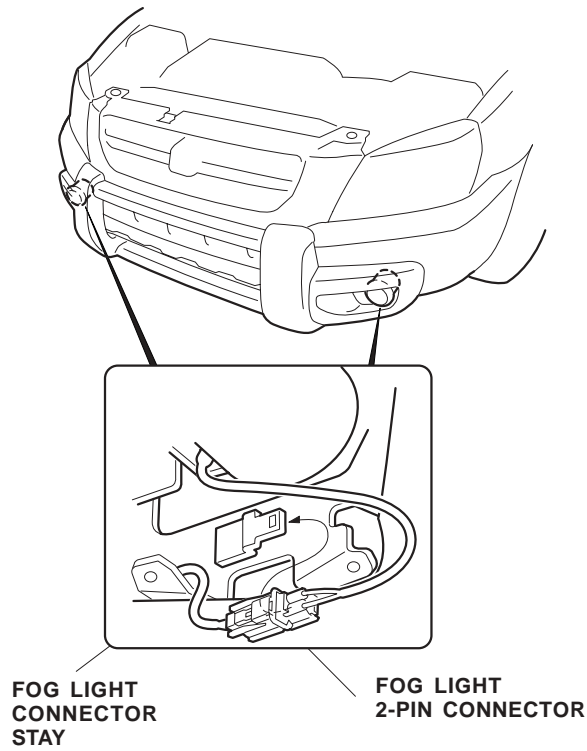

### Routing the Switch Harness

45. Remove the fuel lid door opener knob.

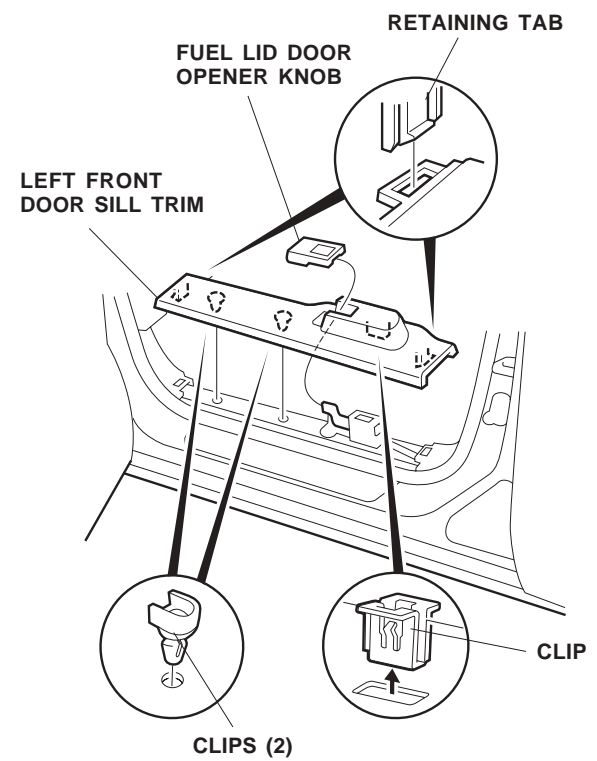

46. Remove the left front door sill trim (three clips and two retaining tabs).
47. Remove the weatherstrip from the left kick panel.

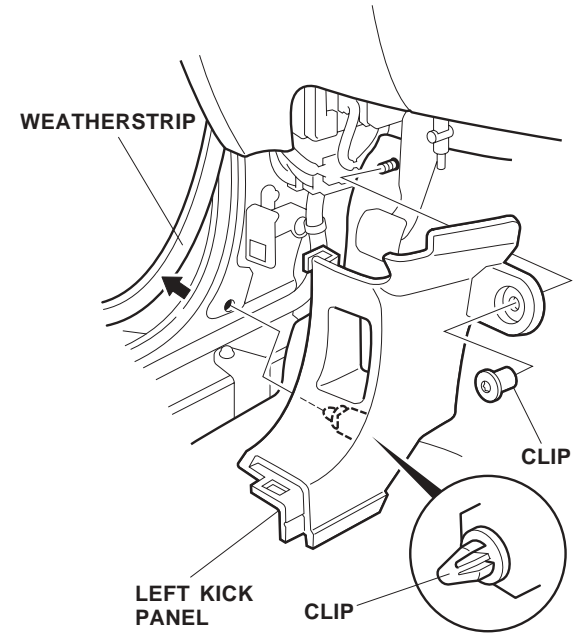

48. Remove the upper clip from the left kick panel, then pull the left kick panel out toward you to release the remaining clip.

49. Remove the left dashboard side cover (four clips, one retaining tab, and seven hooks). Use a clip remover to release the clips.

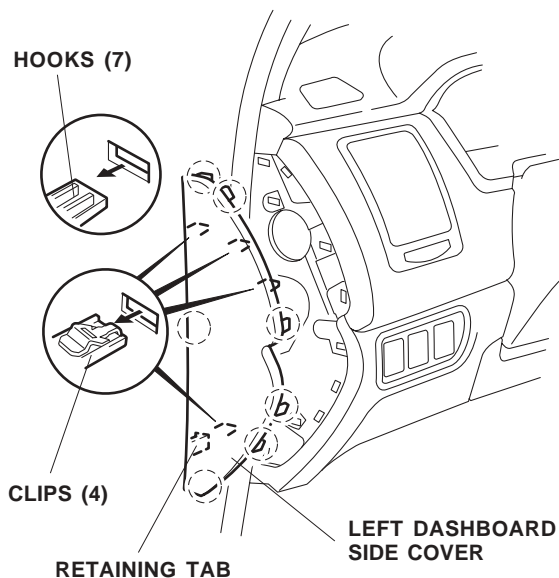

50. Get the switch harness. Plug the two 6-pin connectors of the switch harness into the two 6-pin connectors on the fuse box.

*Without Automatic Day/Night Mirror:*

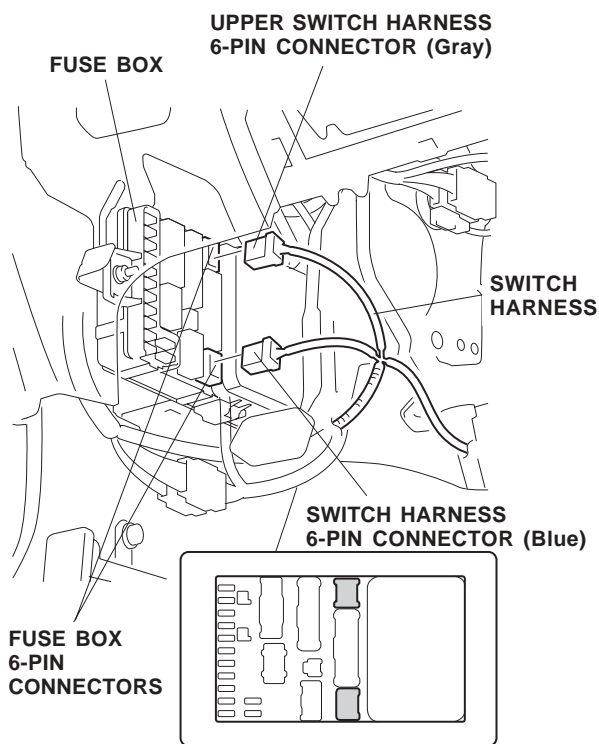

*With Automatic Day/Night Mirror:*

If you are also installing an accessory automatic day/night mirror, connect the 6-pin connectors from the automatic day/night mirror between the upper switch harness 6-pin (gray) connector (gray) and the fuse box.

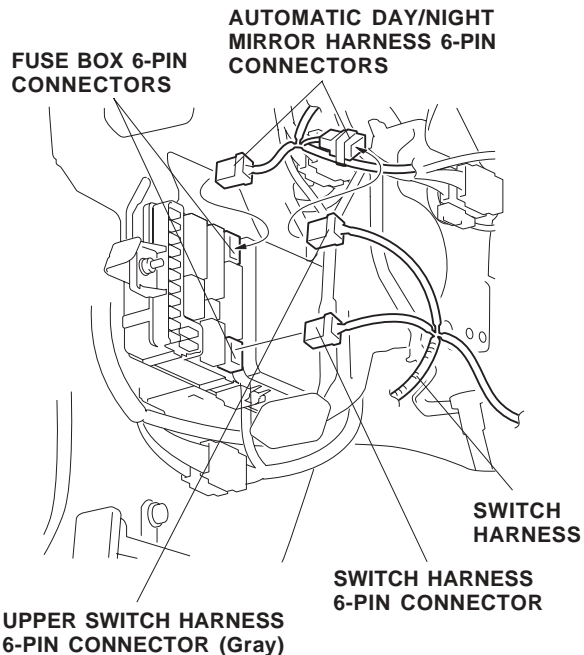

51. Remove and discard the switch cover from the switch panel.

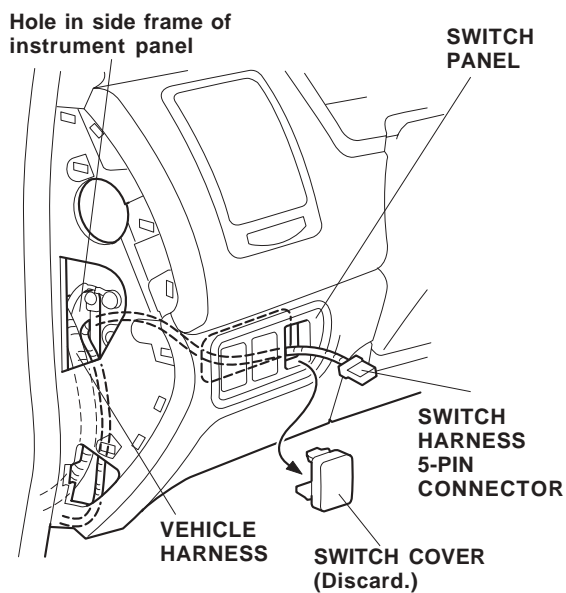

52. At the left dashboard opening, route the switch harness 5-pin connector up alongside the vehicle harness and through the hole in the side frame, and pull the connector out through switch hole.

53. Get the relay and the control unit bracket. Position the relay on the control unit bracket, and install the washer-bolt and flange nut.

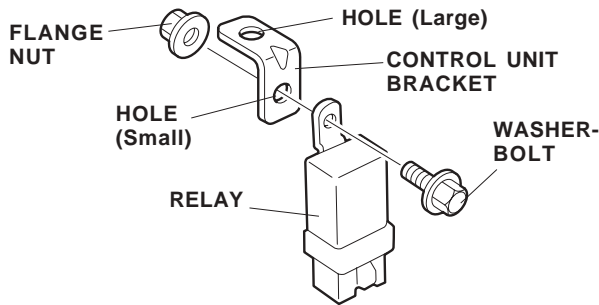

54. Route the switch harness 2-pin connector above the vehicle harness near the parking brake bracket, and plug the switch harness 2-pin connector into the vehicle harness 2-pin connector.

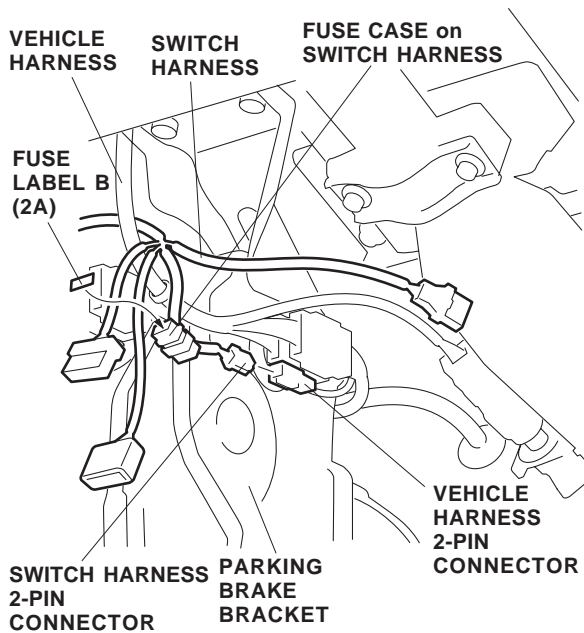

55. Attach the fuse label B (OPTION 2A) to the fuse case on the switch harness.

56. Unplug the vehicle 20-pin connectors and connect the switch harness 20-pin connectors in between.

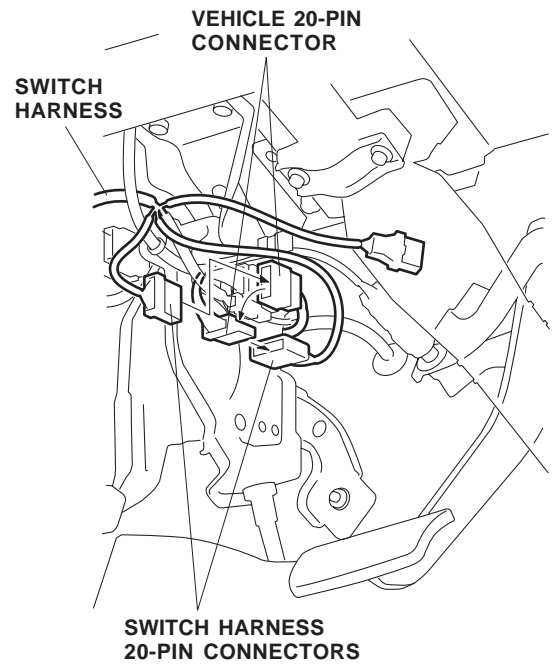

57. Plug the switch harness 4-pin connector into the small relay.

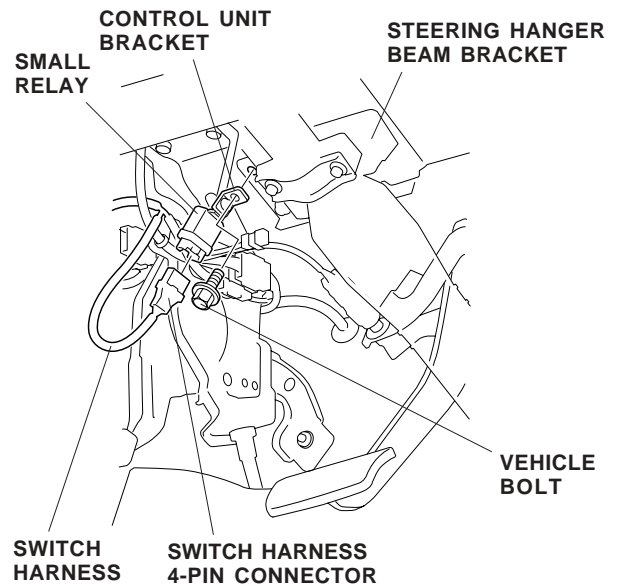

58. Remove the rear bolt that secures the steering hanger beam bracket, and attach the control unit bracket with this bolt. Torque the steering hanger bracket to 19 to 24 N-m (14 to 18 lb-ft).

59. Align the green tape around the switch harness with the vehicle connector on the stop switch harness. Secure the switch harness to the vehicle harness with four wire ties in the areas shown.

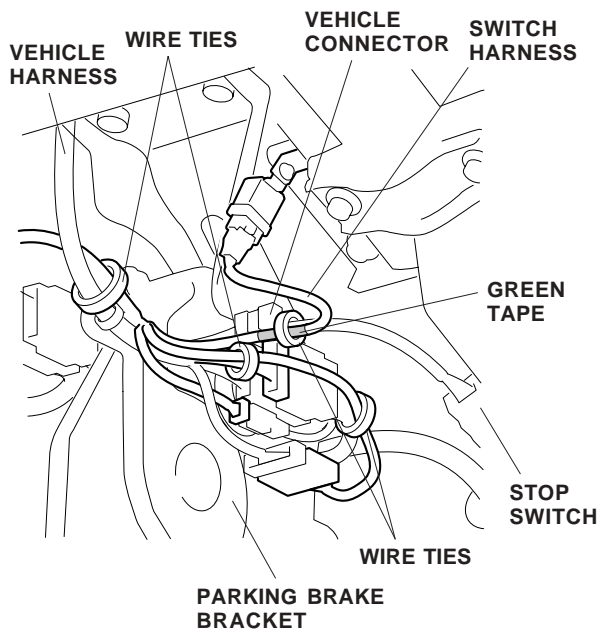

60. Secure the switch harness to the vehicle harness with four wire ties in the areas shown.

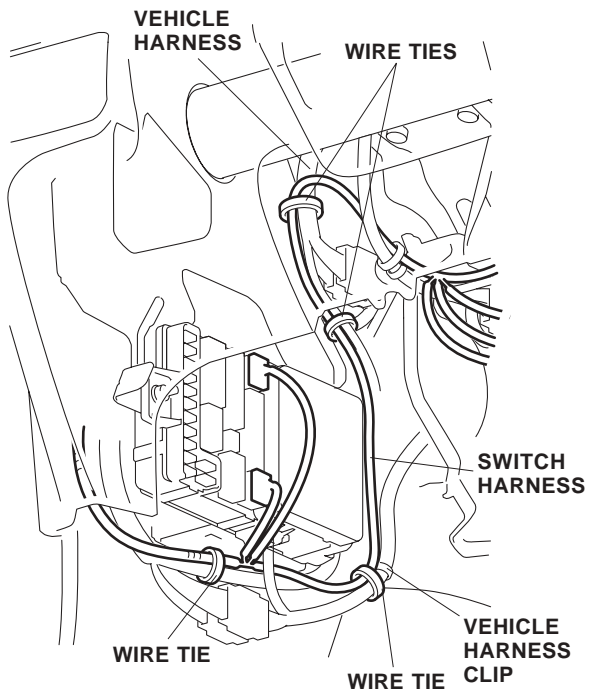

61. At the dashboard opening, secure the switch harness to the vehicle harness with two wire ties.

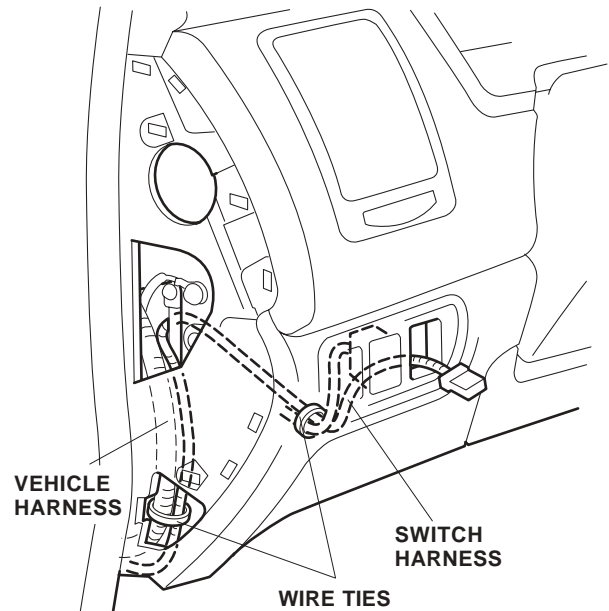

62. Plug the switch harness 5-pin connector into the switch, then install the switch on the switch panel.

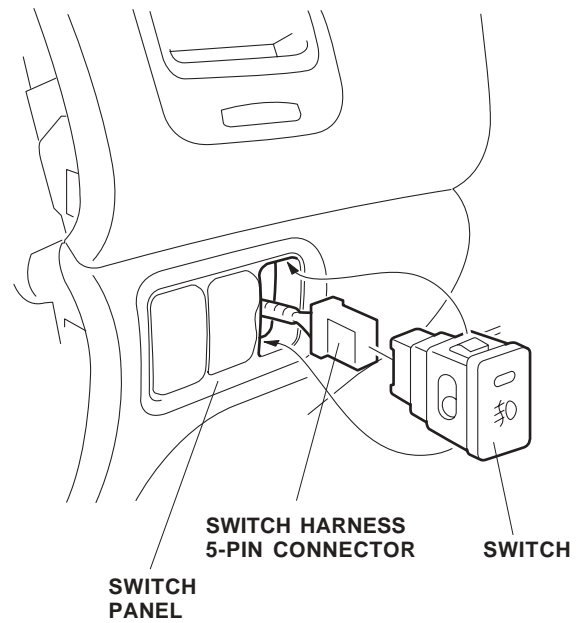

## Adjusting the Fog Light Aiming

63. Adjust the fog light:
- Adjust the aiming according to local laws and regulations.
  - To adjust, turn the aiming adjustment screw in or out until the correct aiming is obtained.

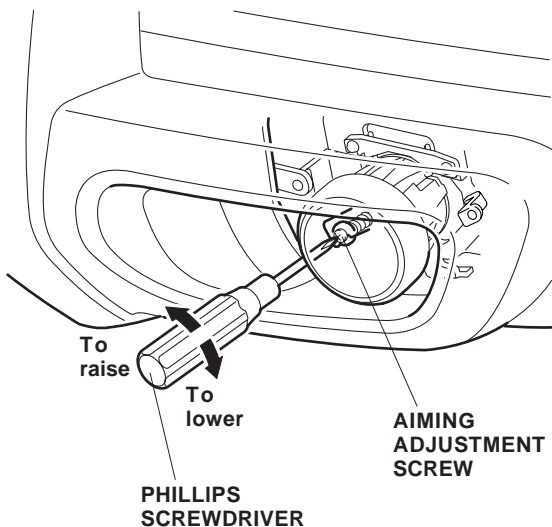

64. Check that all wire harnesses are routed properly and all connectors are plugged in.
65. Reinstall all removed parts. Check that all clips and other fasteners are installed securely.
66. Reconnect the negative cable to the battery.
67. Reset the clock, and reset the radio station presets.
- NOTE: Whenever the battery is disconnected, the driver's window AUTO function is disabled.
68. Start the engine. Push down on the driver's window switch until the window is fully open.
70. Pull up on the driver's window switch to close the window completely, then hold the switch for 2 seconds.
71. Lower and raise the window to check the operation of driver's window AUTO function.

## Installing the Fog Light Cover

72. Fit the left fog light cover into place on the front lower trim and install the two 4 x 12 mm washer-screws. Repeat on the right side.

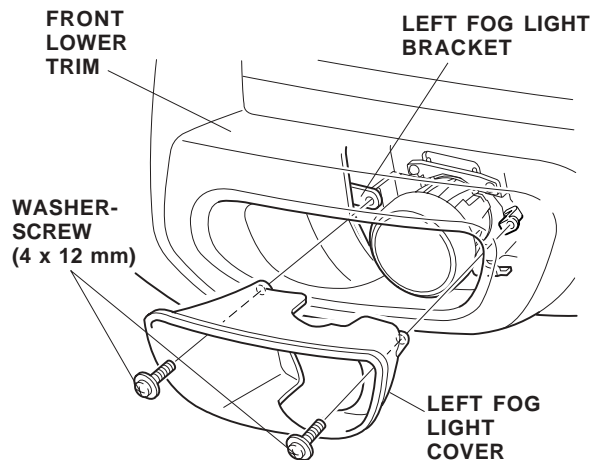

## USE AND CARE

### How to Operate Fog Lights

- Turn the light switch to the "D" position (headlights on low beam).
- Press the fog light switch (indicator is on).

The fog light lenses can cloud when the outside temperature is cold; this is normal and should go away in warm weather.

### Replacing the Fog Light Bulb

1. Remove the fog light cover (two screws).

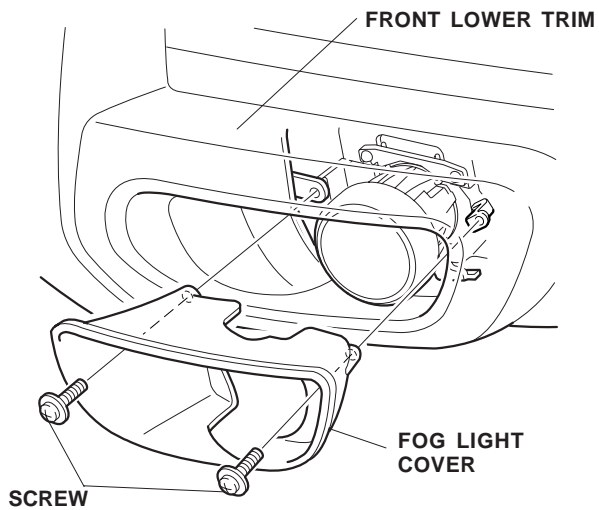

2. Remove the fog light connector from the connector stay, and unplug the connector.

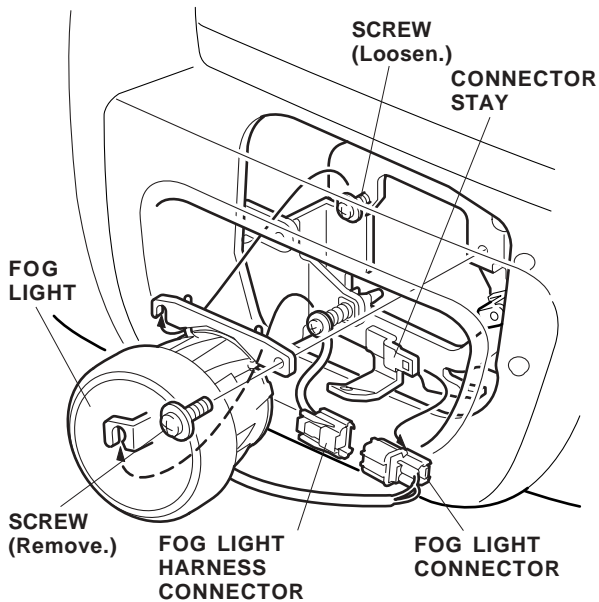

3. Loosen the slotted screw, remove the other screw and remove the fog light.

4. Remove the rear cover from the fog light (five screws).

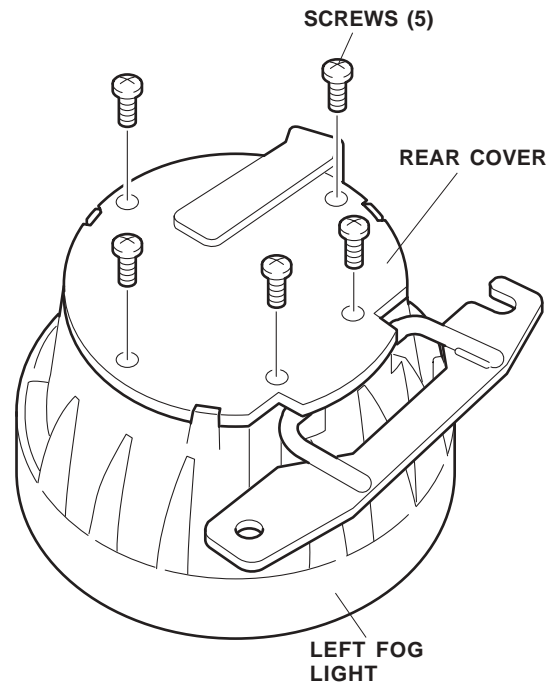

5. Remove the retainer spring, and pull out the bulb and socket as a unit. Replace the bulb with a new one.

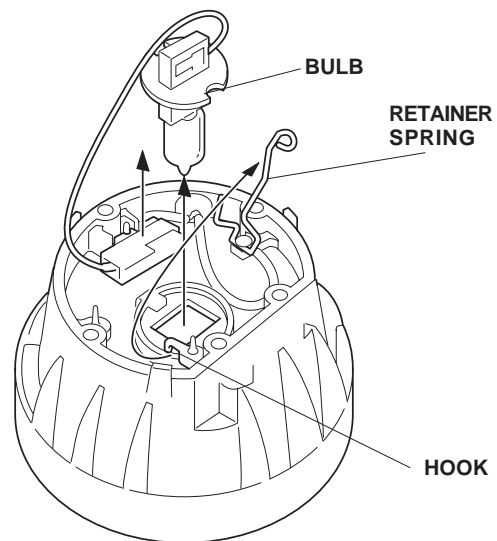

6. Install the new bulb into the socket.
- Use only a genuine Honda halogen light bulb of specified wattage.

Rating: 12V 55W H3 Halogen Light Bulb

- Do not touch the bulb. Oily or greasy substances on the bulb can shorten its service life due to the heat produced when the bulb is turned on. If the bulb is accidentally touched, wipe it clean with a soft cloth that has been dampened with denatured alcohol or a mild detergent solution.
- Align the tab on the fog light with the cutout in the bulb when installing the new bulb. If not aligned, the fog light may annoy oncoming drivers.

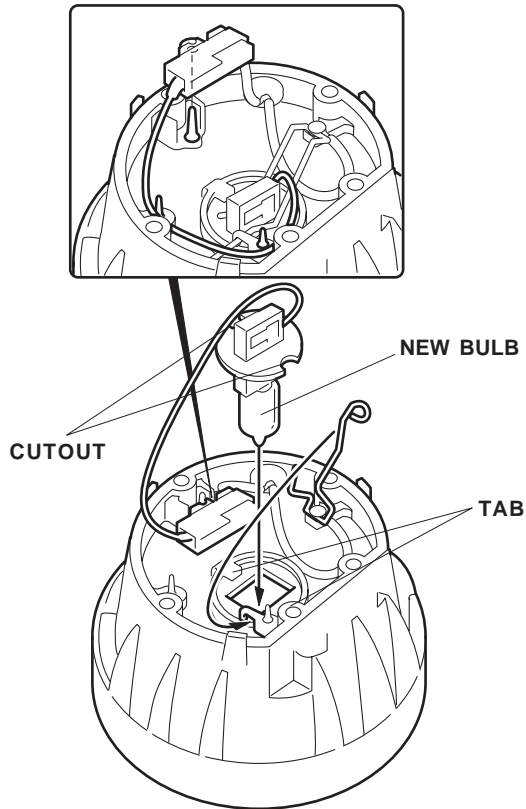

7. Reinstall the removed parts in the reverse order of removal.
- Check that the wire harnesses are not pinched.
  - Make sure you tighten all of the screws securely.

# CIRCUIT DIAGRAM

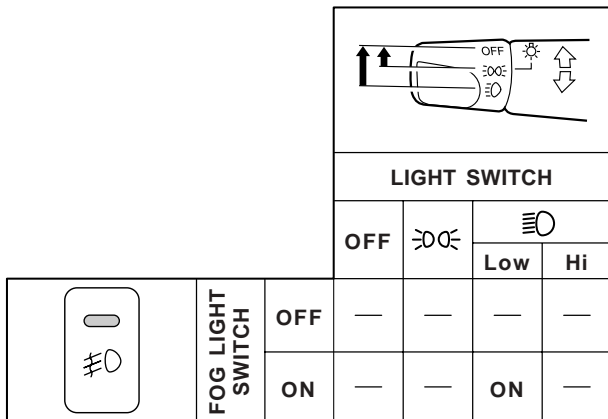
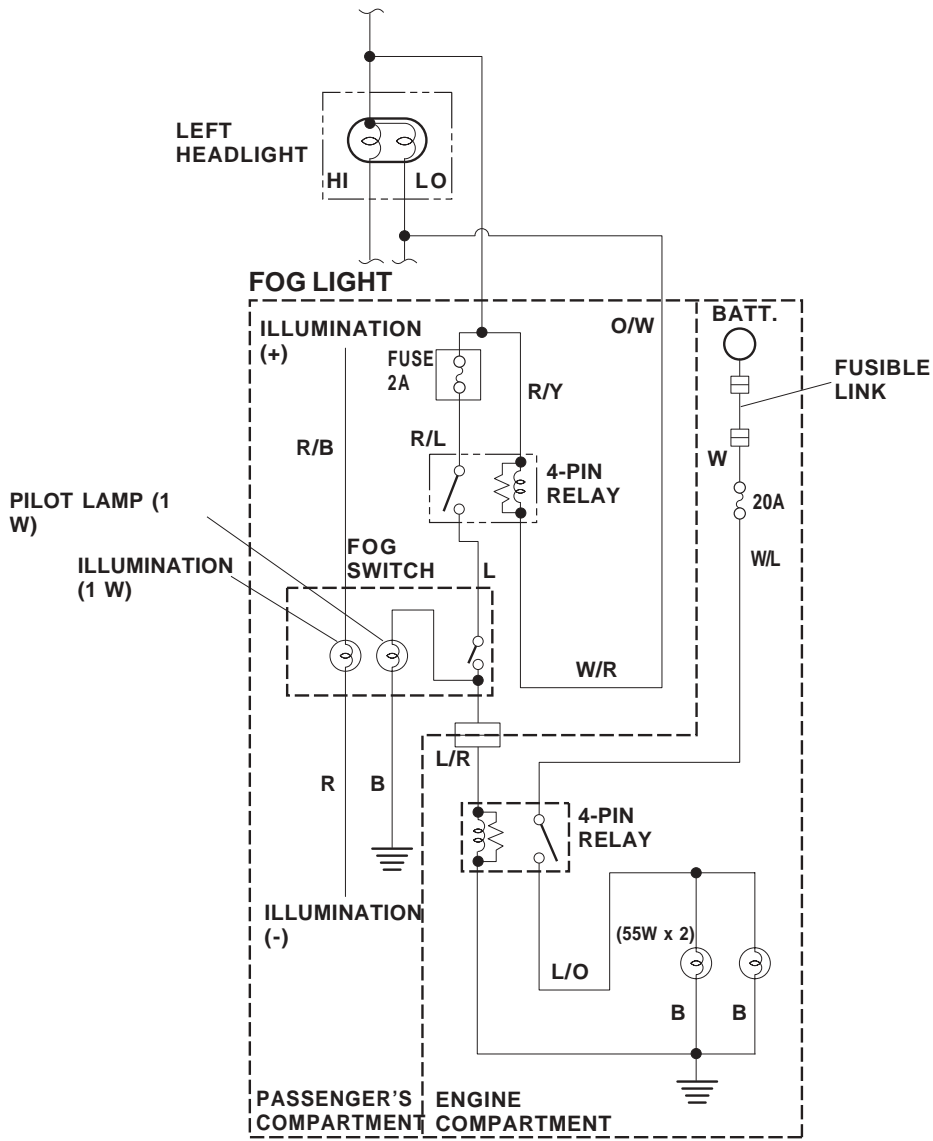

B	BLACK	BR	BROWN
Y	YELLOW	O	ORANGE
L	BLUE	SB	SKY BLUE
G	GREEN	LG	LIGHT GREEN
R	RED	P	PINK
W	WHITE	GR	GRAY

LEFT SIDE BUMPER TEMPLATE

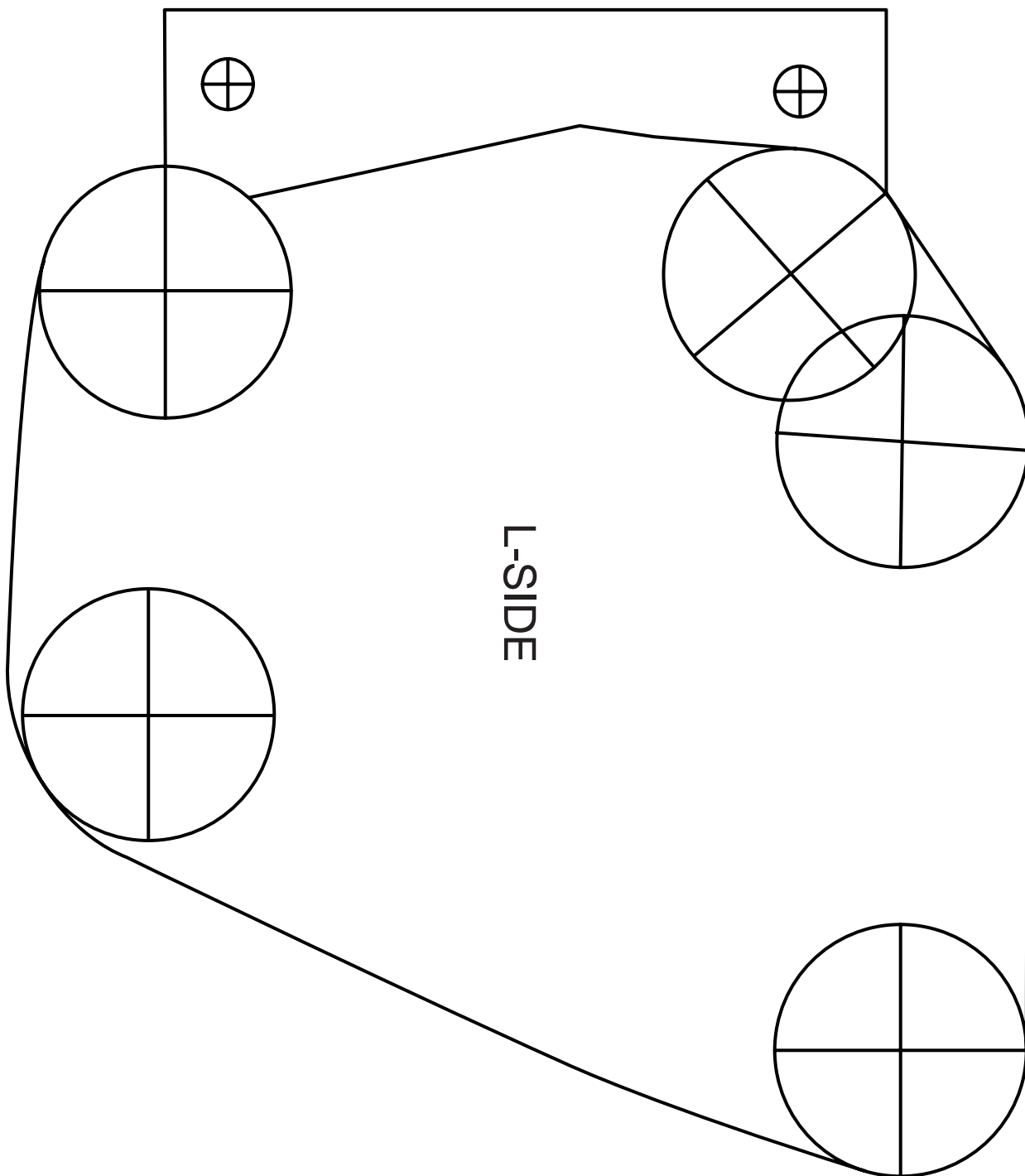

RIGHT SIDE BUMPER TEMPLATE

