



# INSTALLATION INSTRUCTIONS

Accessory

**XM RADIO SYSTEM**

Application

**2007 RIDGELINE**

Publications No.

**All 32459-34084**

Issue Date

**NOV 2006**

## PARTS LIST

**Attachment Kit:  
P/N 08B15-SJC-100A**

2 XM tuner bracket

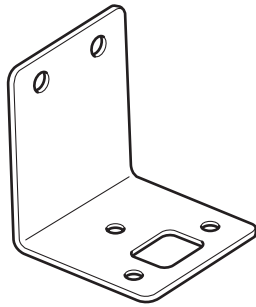

Bus cable

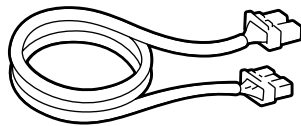

Wire tie with clip

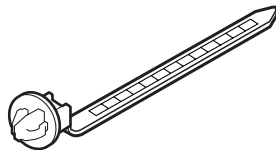

21 Wire ties

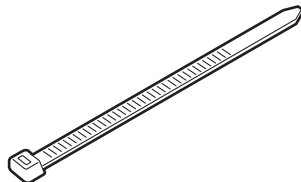

3 EPT sealers

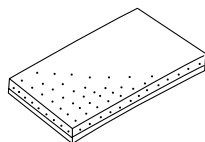

Cushion tape

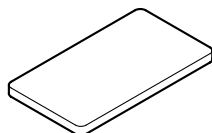

4 Flange nuts, 6 mm



4 Washer-screws, 5 x 8 mm



4 Washer-bolts, 6 x 16 mm

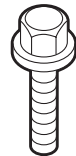

**XM Antenna (sold separately):  
P/N 08A15-0J1-100**

Antenna

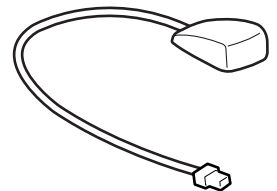

**XM Tuner (sold separately):  
P/N 08A15-3J1-000**

XM tuner

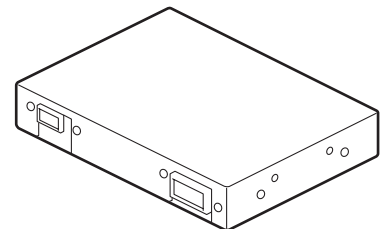

## TOOLS AND SUPPLIES REQUIRED

- Phillips screwdriver
- Flat-tip screwdriver
- 10 mm Combination wrench
- Ratchet
- 8 and 10 mm Socket
- Isopropyl alcohol
- Shop towel
- Tape measure
- Scissors
- Felt-tip pen
- TORX wrench

## Illustration of the XM Radio Installed on the Vehicle

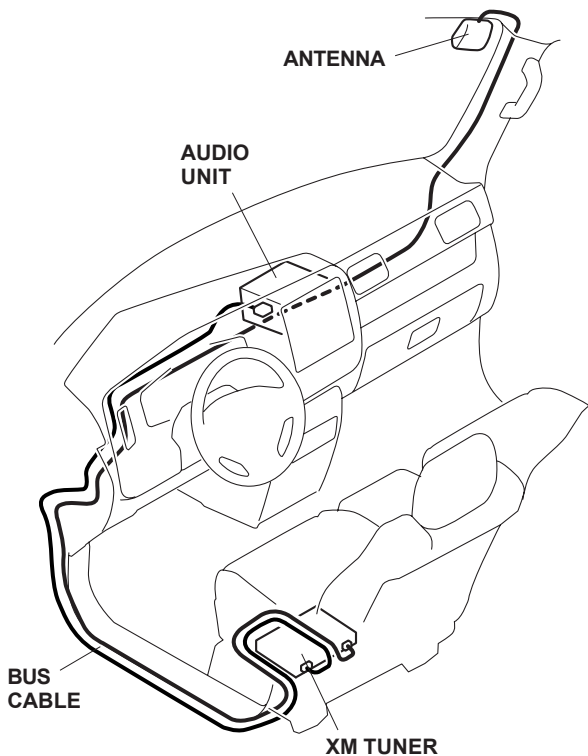

### INSTALLATION

**Customer Information:** The information in this installation instruction is intended for use only by skilled technicians who have the proper tools, equipment, and training to correctly and safely add equipment to your vehicle. These procedures should not be attempted by “do-it-yourselfers.”

1. Make sure you have the anti-theft code for the radio, then write down the radio station presets.
2. Disconnect the negative cable from the battery.

3. Remove the passenger's front grab rail:
  - Remove the screw covers (two retaining tabs for each cover).
  - Remove the two screws, and remove the passenger's grab rail.

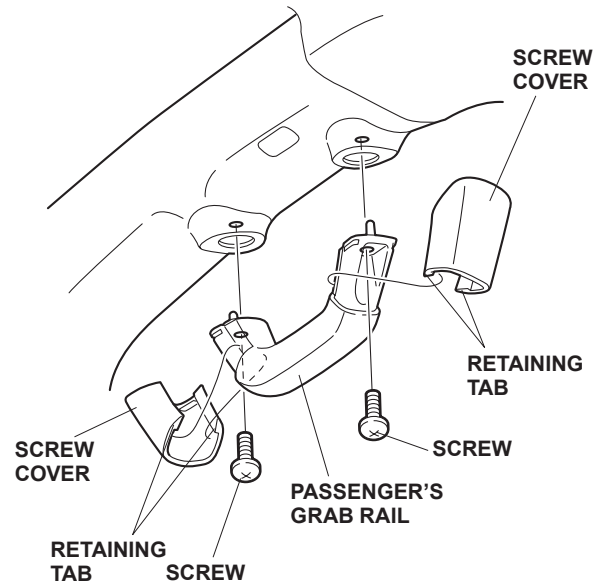

4. Pull away the weatherstrip from around passenger's A-pillar. Remove the passenger's A-pillar trim (two clips).

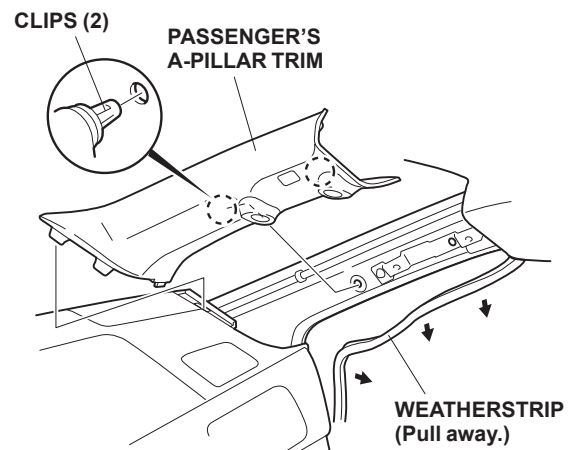

- Remove the right sunvisor screw cover (four retaining tabs), and remove the right sunvisor (two TORX screws, and unplug the vehicle connector).

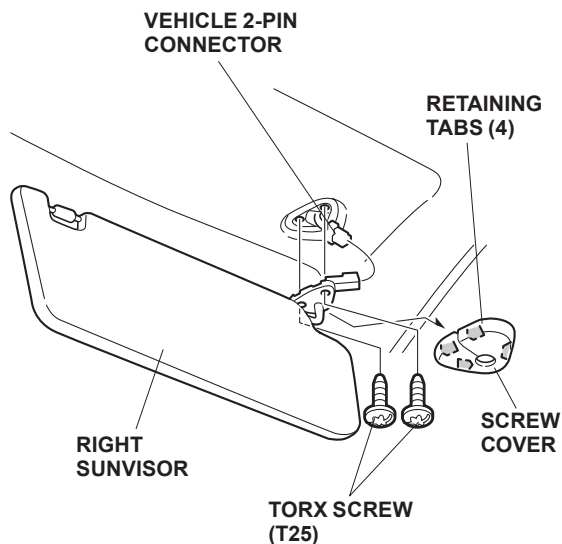

- Open the glove box. Remove the left and right stops from the glove box by releasing the retaining tabs.

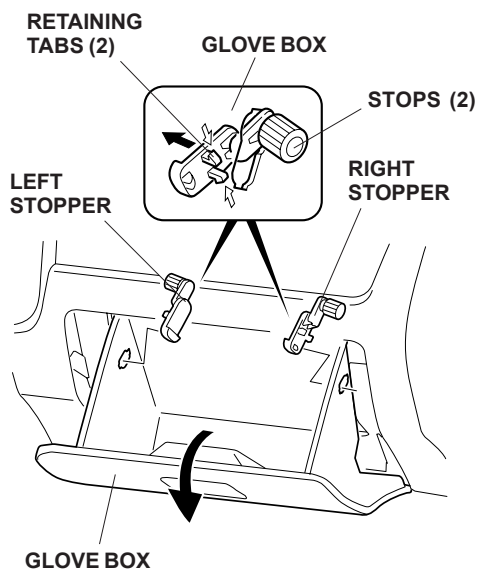

- Remove the left dashboard side cover (seven clips).

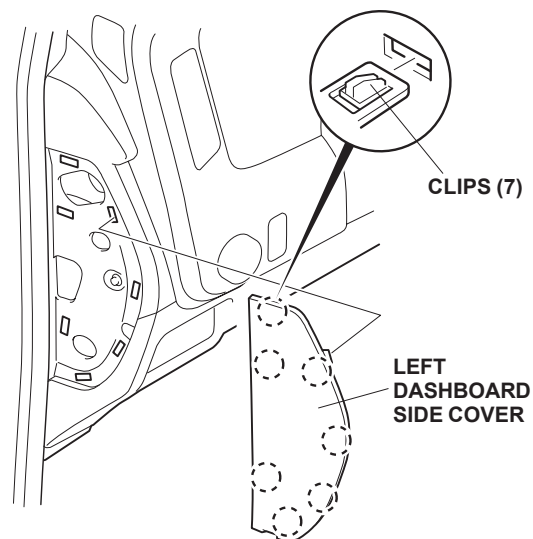

- Insert a flat-tip screwdriver wrapped with a shop towel into the groove of the instrument panel and release the two clips. Pull the instrument panel out toward you to release the eighteen clips, and remove the instrument panel by unplugging the vehicle connectors.

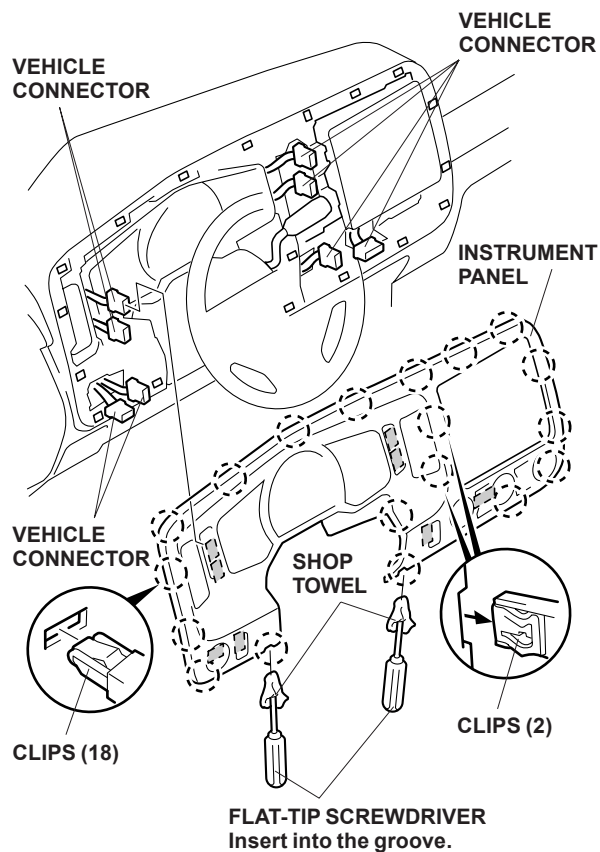

9. Remove the meter assembly (four self-tapping screws, and unplug the three vehicle connectors).

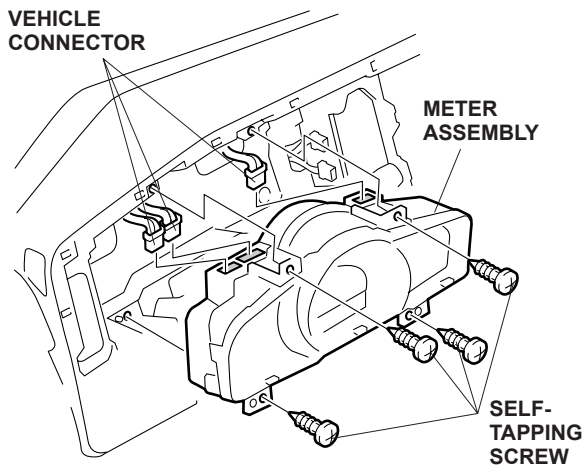

10. Remove the audio unit (five bolts, pull the audio unit out towards you, and unplug the vehicle connectors).

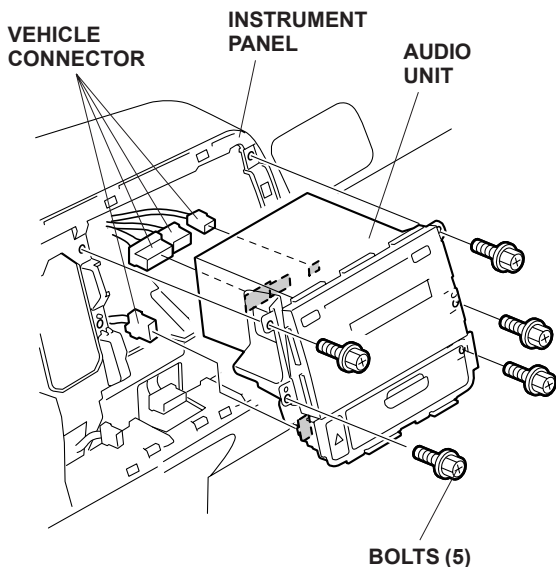

11. Remove the driver's dashboard under cover:

- Remove the one self-tapping screw.
- Release the nine clips, and pull out on the driver's dashboard under cover.
- Unplug the vehicle connectors, and remove the vehicle tube. Remove the driver's dashboard under cover.

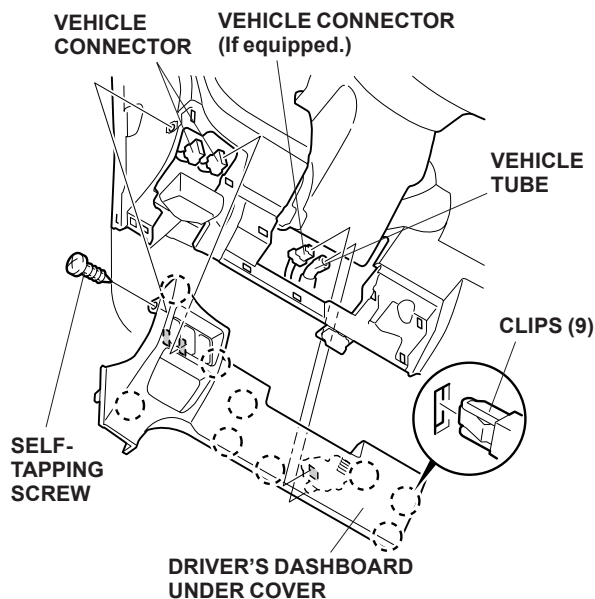

12. Remove the fuel fill door release handle. Remove the left front door sill trim (three clips and three retaining tabs).

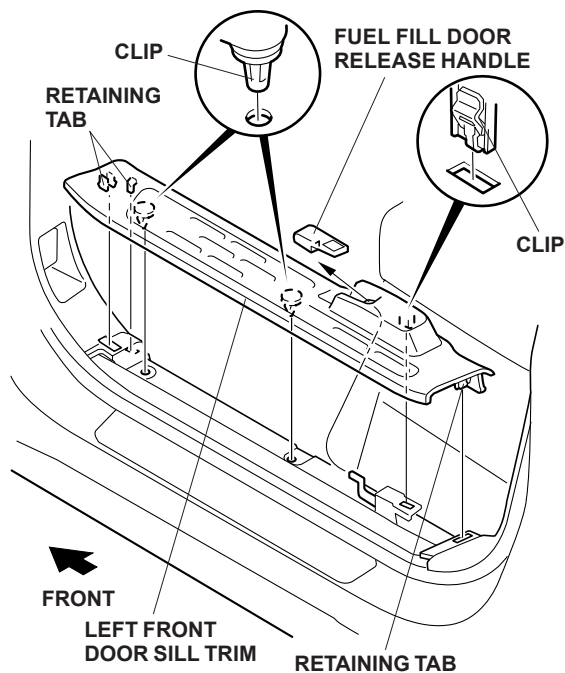

13. Pull away the weatherstrip from around the driver's kick panel. Remove the driver's kick panel (one screw clip and one clip).

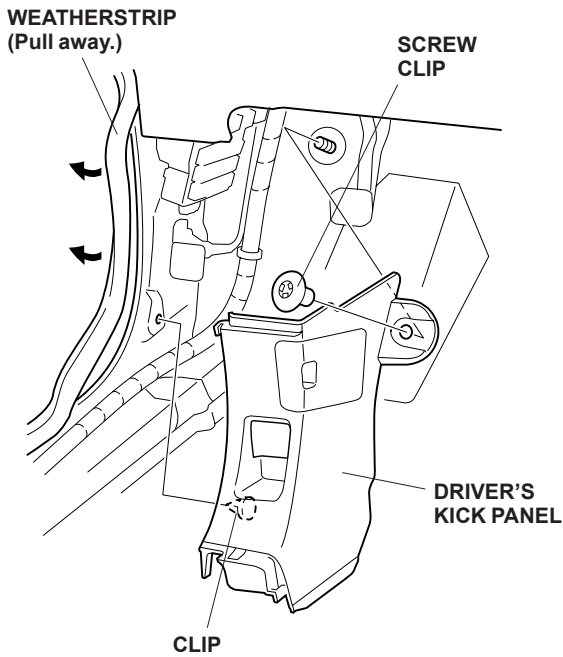

14. Remove the driver's seat frame rear cover (two clips and two hooks).

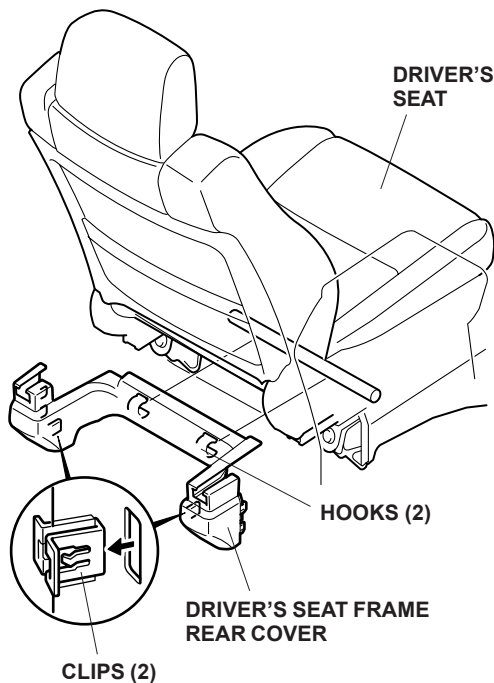

## Installing the Antenna

15. Using isopropyl alcohol on a shop towel, clean the right front upper corner on the inside of the front window. Remove the four adhesive backings from the antenna, and attach the antenna to the front window at the location shown. Install the antenna by applying sufficient pressure.

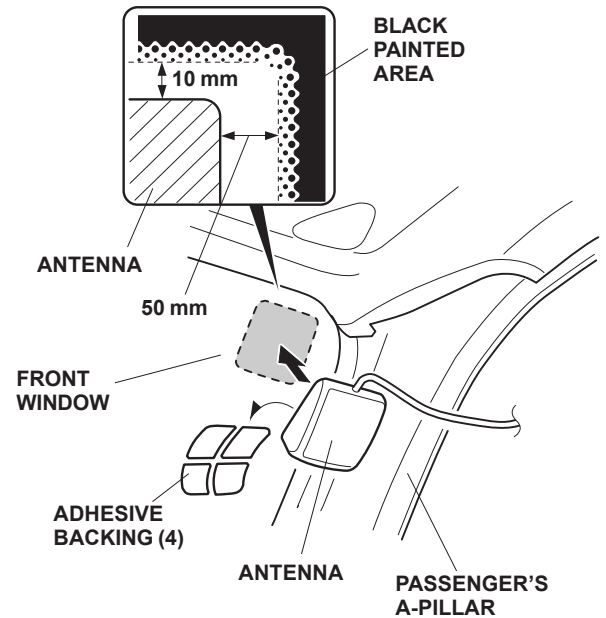

16. Route the antenna harness down the passenger's A-pillar along the vehicle harness, secure the antenna harness to the vehicle harness with three wire ties in areas shown.

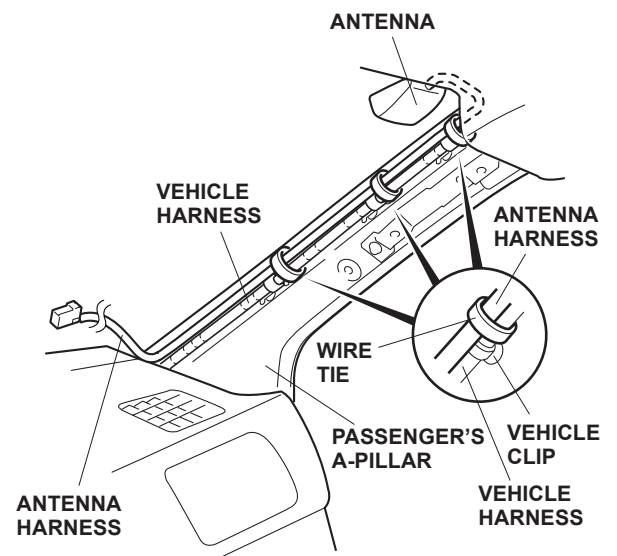

17. Using a felt-tip pen, mark the antenna harness at the point where the harness touches the dashboard.

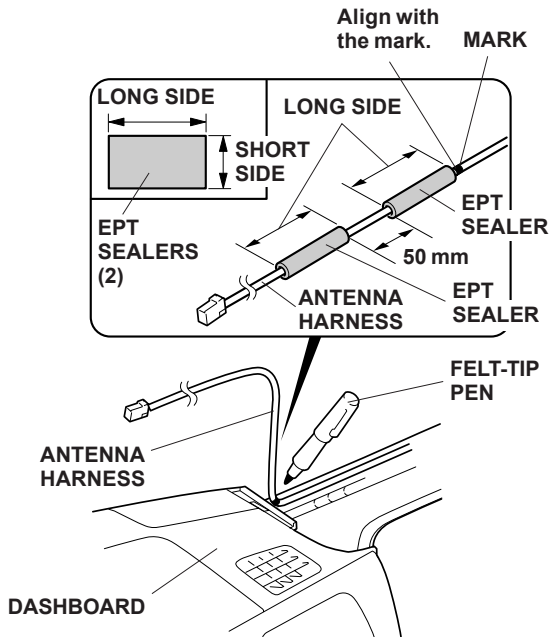

18. Wrap two EPT sealers around the antenna harness at the locations shown.
19. Route the antenna harness down behind the dashboard and towards the glove box. Secure the antenna harness to the vehicle harness with one wire tie.

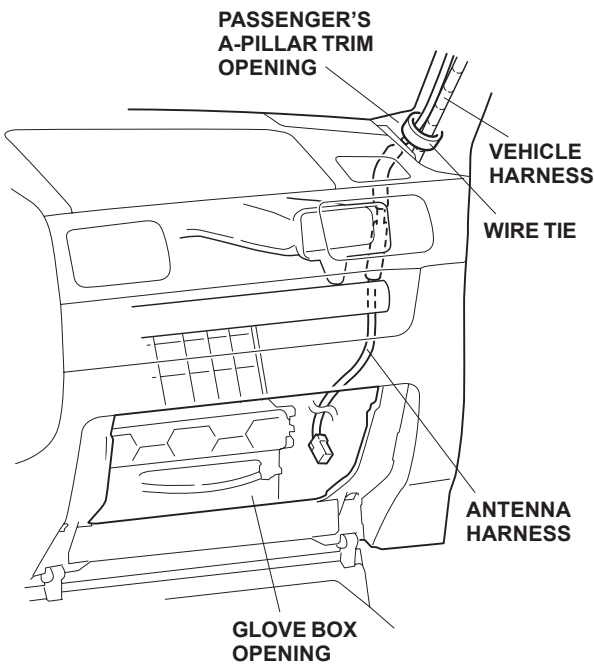

20. Inside the glove box opening, route the antenna harness along the vehicle harness and towards the driver's side of the vehicle. Secure the antenna harness to the vehicle harness with three wire ties in areas shown.

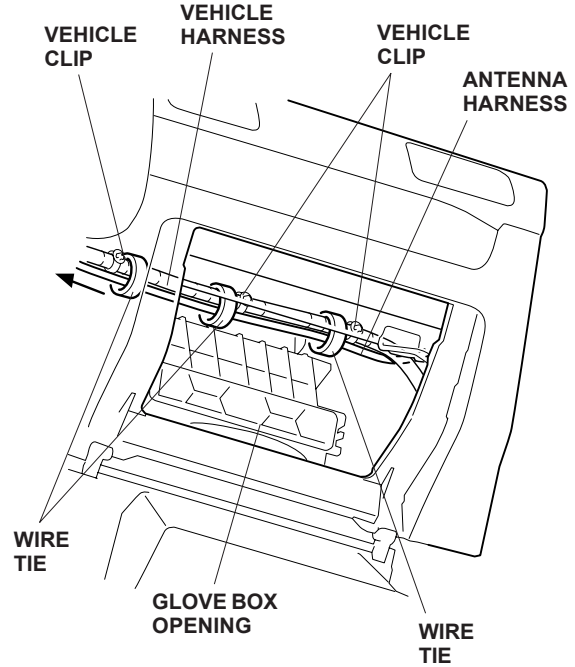

21. Route the antenna harness past the audio unit opening, and secure the antenna harness to the vehicle harness with one wire tie.

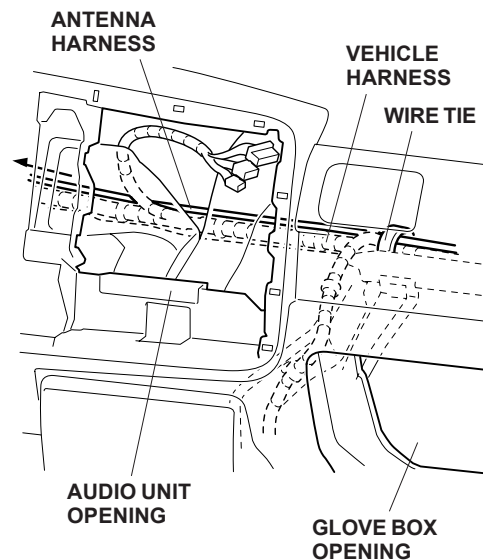

22. Route the antenna harness as shown and temporarily secure it to the vehicle harness using two wire ties.

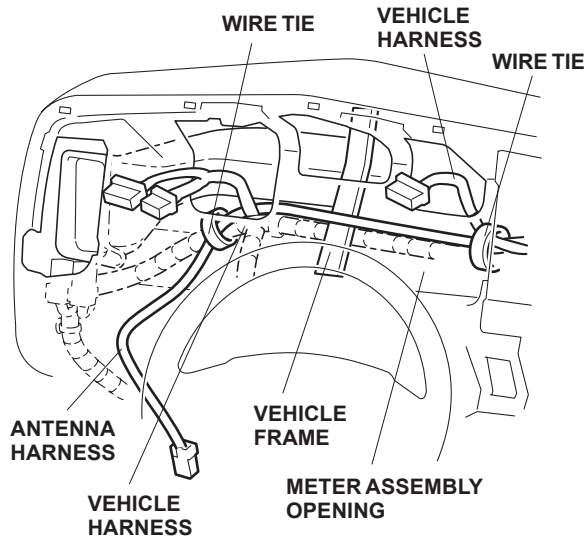

23. Route the antenna harness along the vehicle harness and temporarily secure it to the vehicle harness using four wire ties.

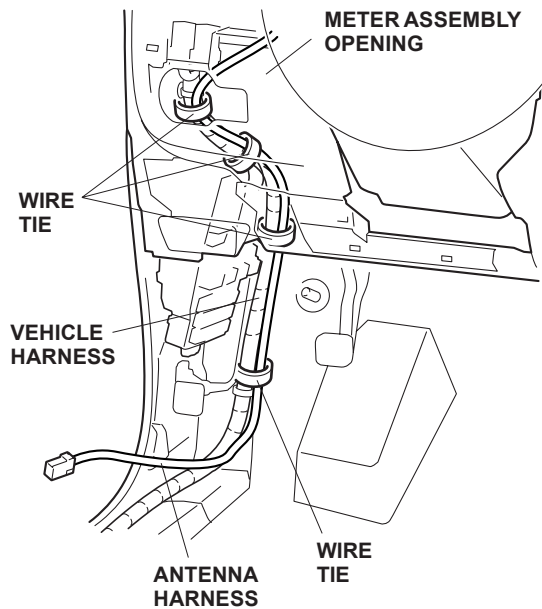

24. Route the antenna harness as shown and temporarily secure it to the vehicle harness using four wire ties.

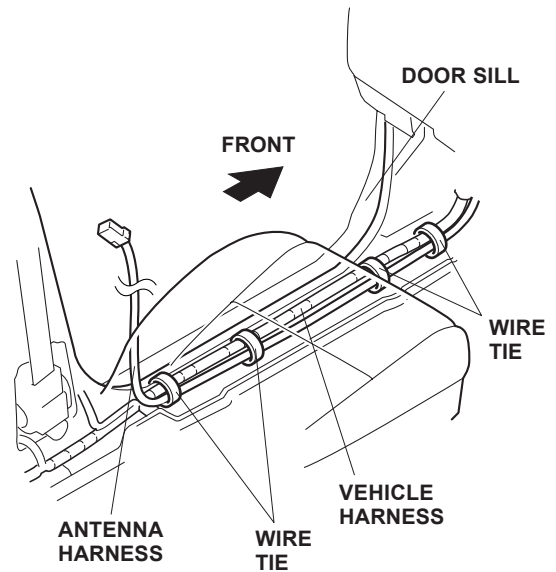

25. Route the antenna harness and BUS cable under the floor carpet and pull them out of the cutout in the floor carpet.
26. Adjust the antenna harness and BUS cable you just pulled out of the cutout in the floor carpet to the length shown.

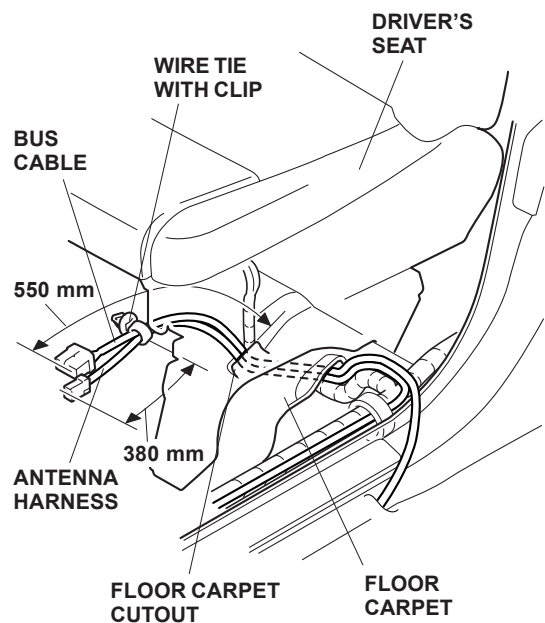

27. Bind the antenna harness and BUS cable together in the position shown using a wire tie with clip.

## Installing the XM Tuner

28. Install the XM tuner brackets to the XM tuner with four 5 x 8 mm washer-screws.

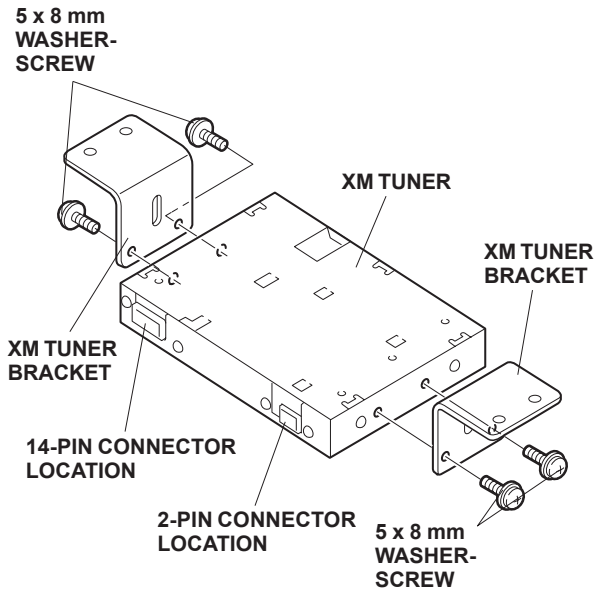

29. Install the XM tuner brackets to the driver's seat panel with four 6 x 16 mm washer-bolts and four 6 mm flange nuts.

NOTE: If the vehicle is equipped with seat plate with welded nuts, the four flange nuts are not used.

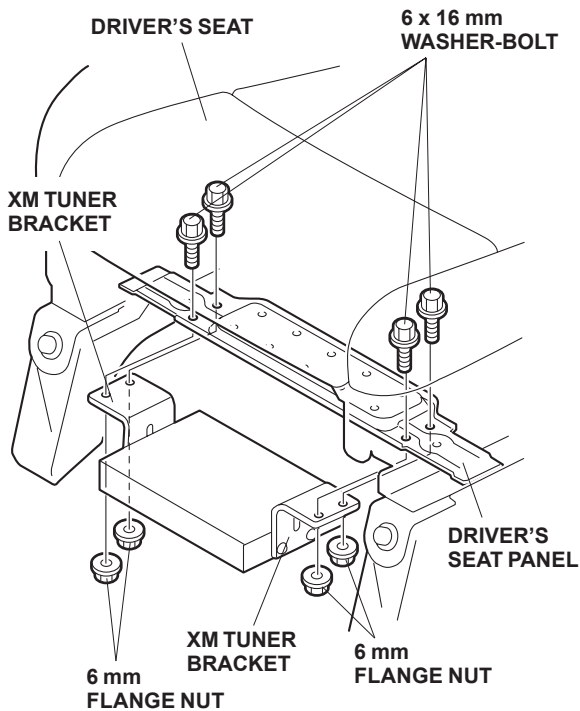

30. Connect the antenna harness 1-pin connector and BUS cable 14-pin connector to the XM tuner.

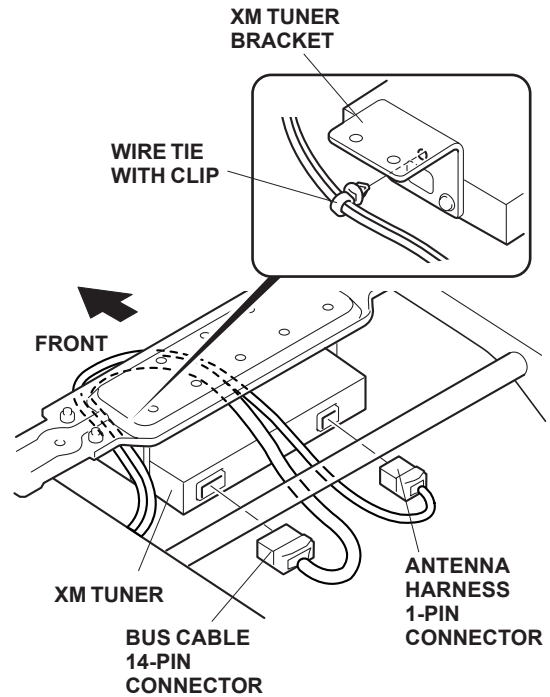

31. Install the wire tie with clip, with which you bound the antenna harness and BUS cable together in step 27, on the XM tuner bracket.
32. Using an isopropyl alcohol clean the vehicle panel surface where the EPT sealer will be attached. Attach the antenna harness cord and BUS cable cord to the XM tuner using a cushion tape as shown.

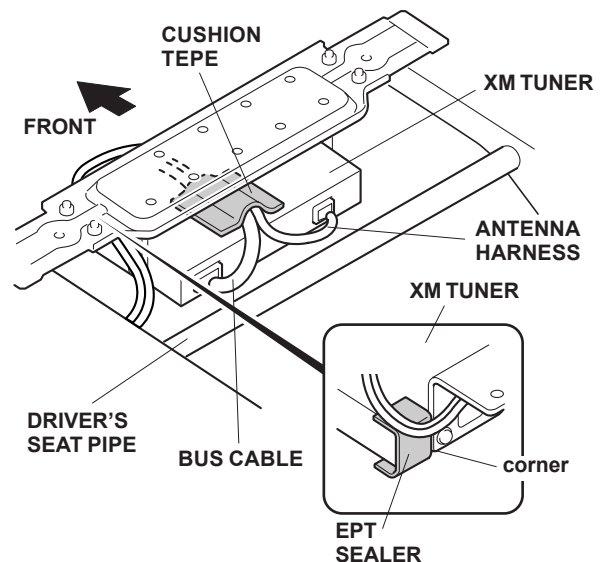

33. Attach the EPT sealer to the corner of the XM tuner as shown.

34. Route the BUS cable and antenna harness to the front side of the car and secure it to the vehicle harness using four wire ties.

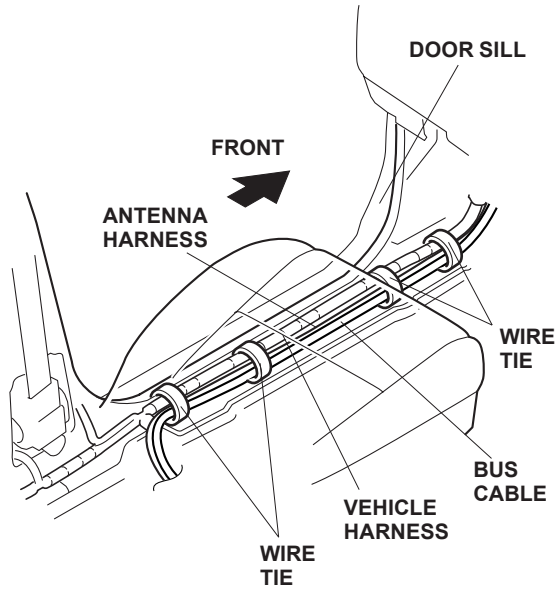

35. Route the BUS cable and antenna harness to the top of the car and secure it to the vehicle harness using four wire ties.

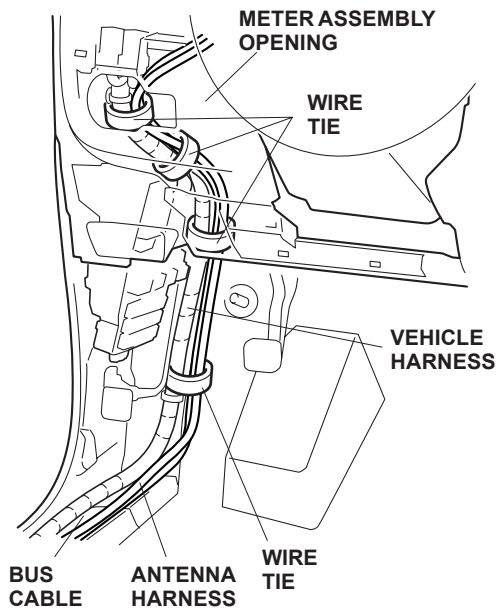

36. Route the BUS cable as shown. Secure the BUS cable and antenna harness to the vehicle harness using two wire ties as shown.

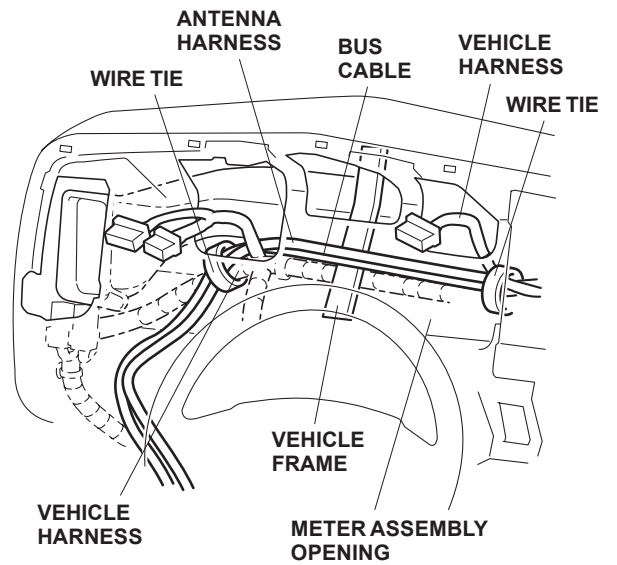

## Routing the Bus Cable

37. Align the end of the bus cable connector with the end of the vehicle 20-pin connector and secure the bus cable to the vehicle harness using a wire tie.

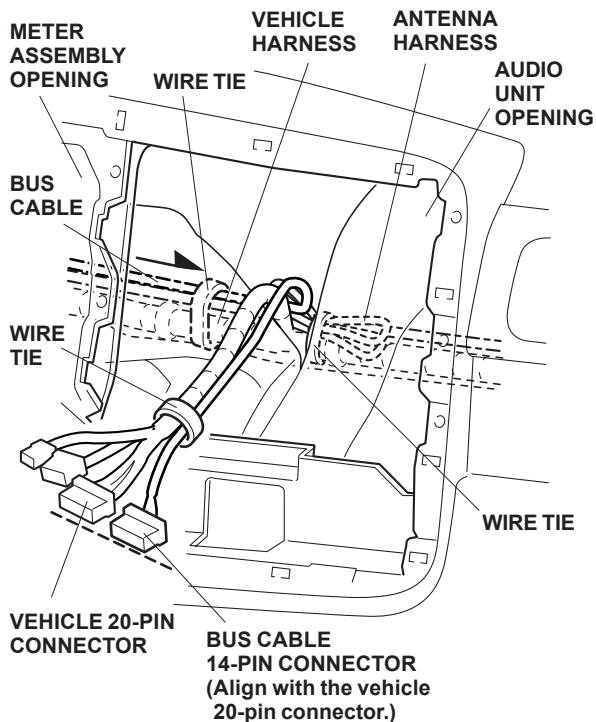

38. Secure the bus cable and antenna harness to the vehicle harness using a wire tie. Bundle the excess of the antenna harness and secure it to the vehicle harness using a wire tie.
39. Plug the bus cable 14-pin connector and vehicle connectors into the audio unit/player.

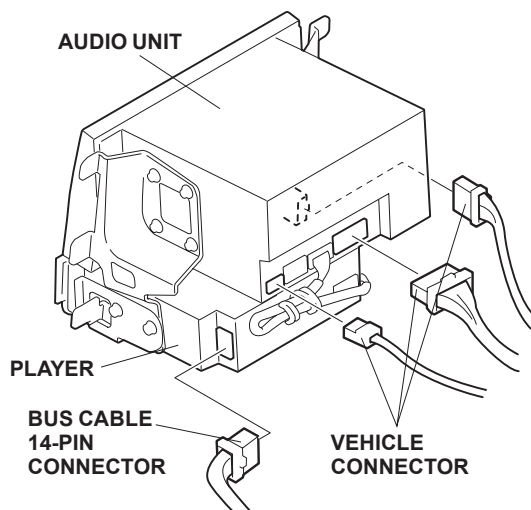

## With Player

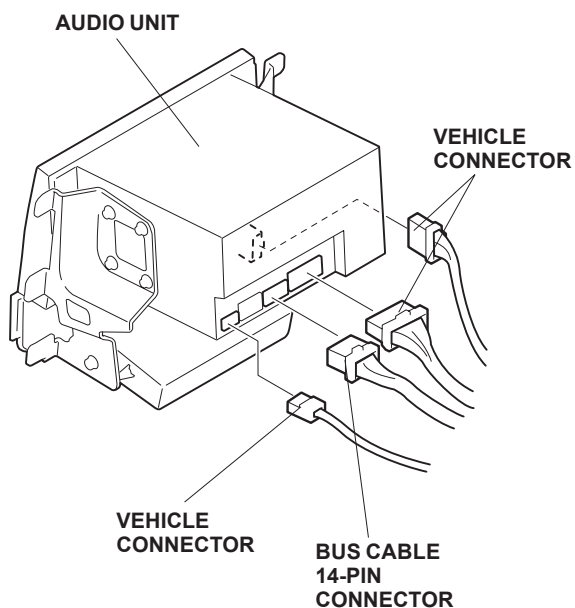

## Without Player

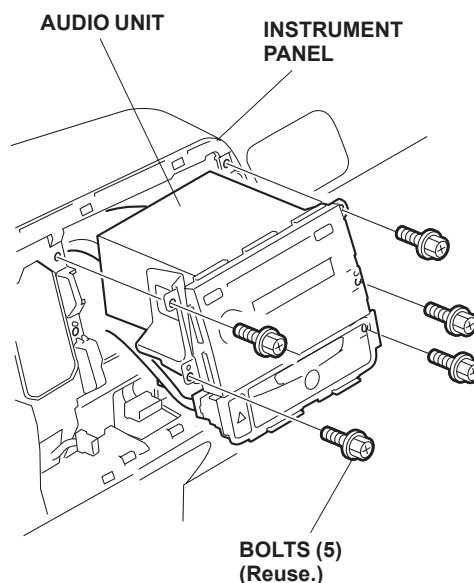

40. Reinstall the audio unit.
41. Slide the driver's seat back and forth to check that the antenna harness and bus cable are not pulled too tight or end up too loose.

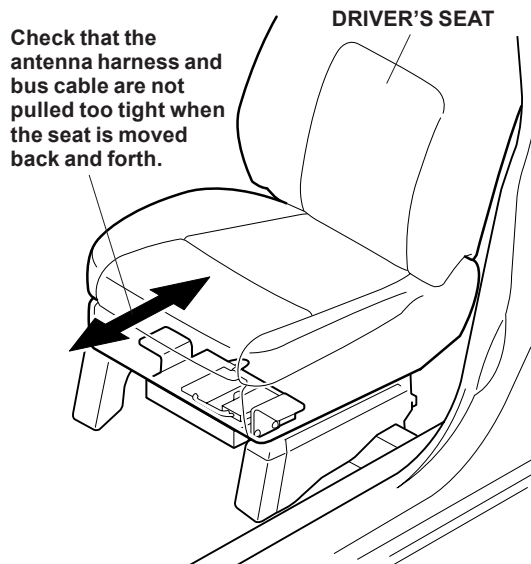

42. Check that all wire harnesses are routed properly and all connectors are plugged in.
43. Reconnect the negative cable to the battery.
44. Enter the customer's radio anti-theft code, and reset the radio station presets.
45. Set the clock.
46. Check the operation of the XM radio system according to the vehicle's Owner's Manual supplied.
47. Reinstall all removed parts.

NOTE: Whenever the battery is disconnected, the driver's window AUTO function is disabled.

48. Start the engine. Push down on the driver's window switch until the window is fully open.
49. Pull up on the driver's window switch fully to close the window completely, then hold the switch for 2 seconds or more.
50. Test the window AUTO function.