

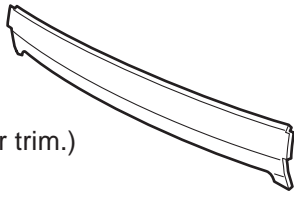





INSTALLATION INSTRUCTIONS

Accessory	Application	Publications No.
BUMPER TRIM P/N 08F23-SJC-100	RIDGELINE	All 28593
		Issue Date
		FEB 2005

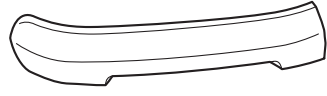
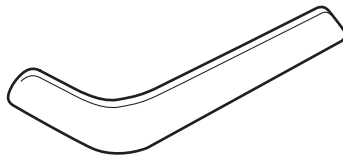
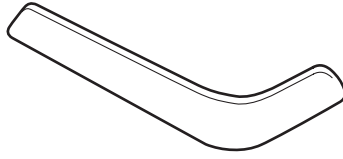
PARTS LIST

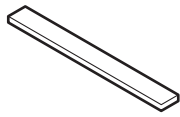
- Center front bumper trim
(Not used if the vehicle is equipped with a front lower trim.) 
- Left front bumper trim 
- Right front bumper trim 
- Left rear bumper trim 
- Right rear bumper trim 
- 15 Brackets
(Three of these brackets are not used if the vehicle is equipped with a front lower trim.) 
- 15 Nuts
(Three of these nuts are not used if the vehicle is equipped with a front lower trim.) 
- 2 EPT sealers
(Used only when the vehicle is equipped with a front lower trim.) 

TOOLS AND SUPPLIES REQUIRED

- Phillips screwdriver
- Flat-tip screwdriver
- Ratchet
- 8 mm and 10 mm Socket
- Masking tape
- Isopropyl alcohol
- Shop towel
- Gloves
- Drill
- 3 mm and 10 mm Bits
- 1 3/16 in. (30 mm) and 2 in. (51 mm) Holesaw
- File
- Eye protection (face shield, safety goggles, etc.)
- Touch up paint
- Blanket
- Center punch

INSTALLATION

Customer Information: The information in this installation instruction is intended for use only by skilled technicians who have the proper tools, equipment, and training to correctly and safely add equipment to your vehicle. These procedures should not be attempted by "do-it-yourselfers."

NOTE:

- Be careful not to damage the body finish.
 - This bumper trim kit should only be installed if the ambient air temperature is above 60°F (15°C).
 - To allow the adhesive time to "cure," do not wash the vehicle for 24 hours.
1. Make sure you have the anti-theft code for the radio, then write down the radio presets.
 2. Disconnect the negative cable from the battery.

Installing the Front Bumper Trim

3. Open the hood, remove the front bumper (seven clips, four bolts, two short step bolts and two self-tapping screws). Place the front bumper on a blanket. If equipped, remove the lower trim.

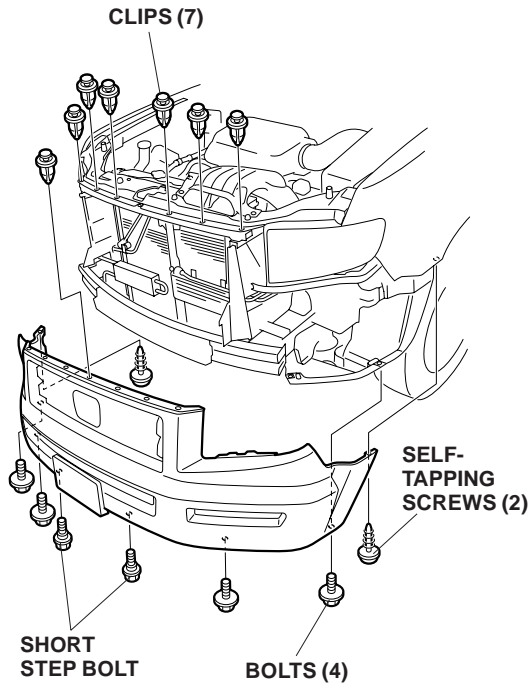

If you are also installing a front lower trim, go to step 10; otherwise, go to step 4.

4. On the inside of the front bumper, locate the three marks for the front bumper trim. Center punch the three marked locations on the front bumper. While wearing eye protection, drill a 1 3/16 in. (30 mm) hole through the three marked locations.
 - First drill with a 3 mm drill bit, and finish with a 1 3/16 in. (30 mm) holesaw. Remove all burrs from the edges of the holes with a file.
 - Be careful not to confuse the marks with those provided for front lower trim.

MARK FOR FRONT BUMPER TRIM

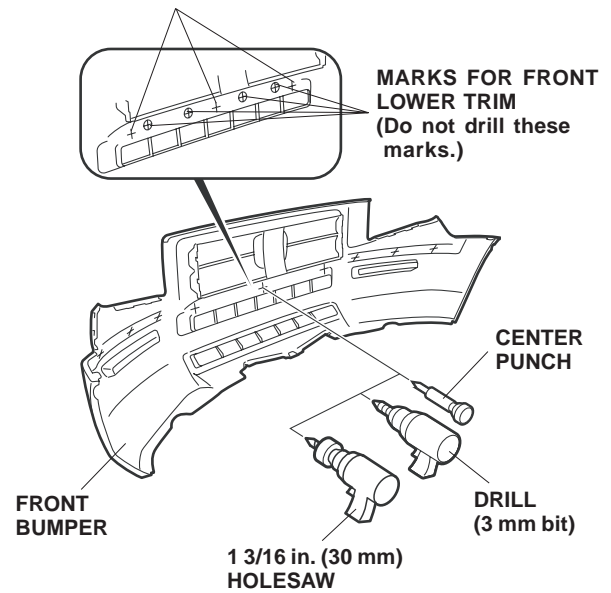

- On the back of the center front bumper trim, peel back 1 1/2 to 2 in. (3-5 cm) from each long adhesive backing, and attach it to the front of the trim with masking tape. Remove the three short adhesive backings.

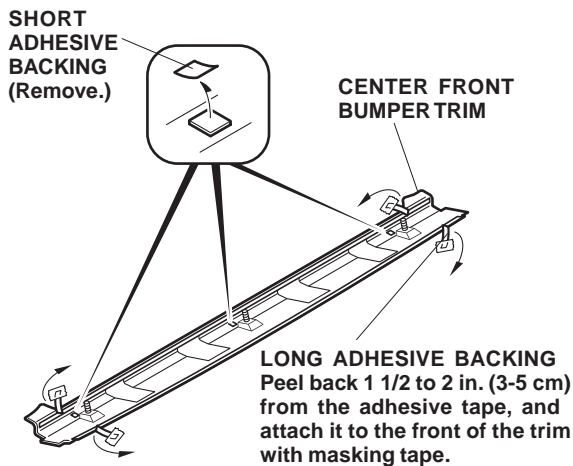

- Using isopropyl alcohol on a shop towel, clean the areas where the center front bumper trim will attach.
- Position the center front bumper trim on the front bumper, and install three brackets and three nuts. Do not tighten the nuts at this time.

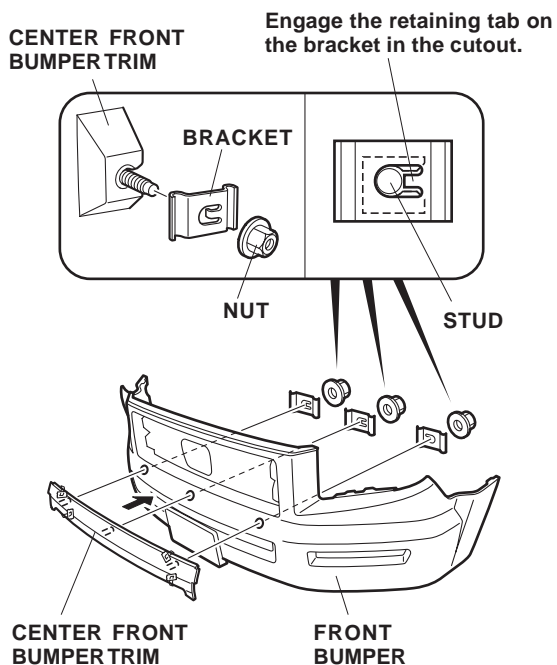

- While holding light pressure on the trim, carefully remove the adhesive backings from the trim. After removing the adhesive backings, hold the trim firmly against the front bumper with the palm of your hand for 30 seconds.

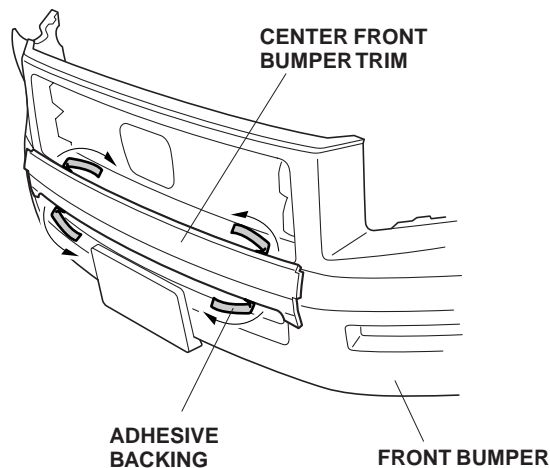

- Tighten the three nuts.

If you are NOT installing a front lower trim, go to step 15.

- Center punch the ten marked locations on the front bumper. While wearing eye protection, drill a 10 mm hole through the ten marked locations. First drill with a 3 mm drill bit, and finish with a 10 mm drill bit. Remove all burrs from the edges of the holes with a file.

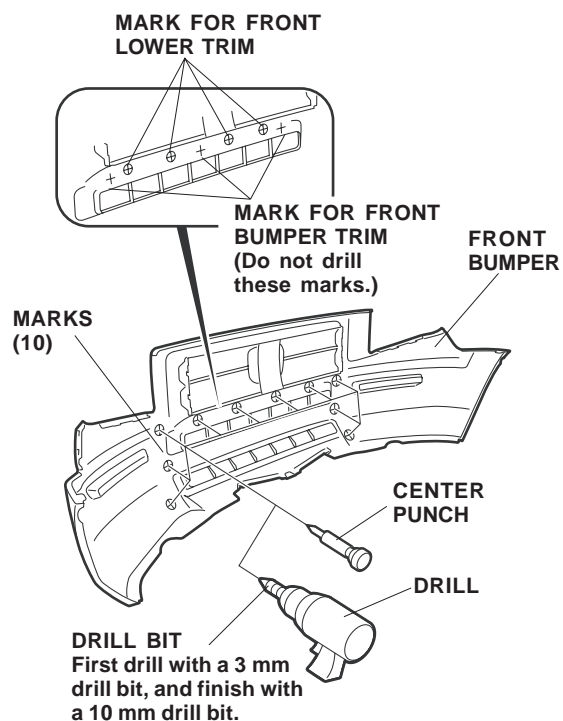

11. Get the left front bumper trim. While wearing eye protection, drill a 3 mm hole through the mark on the inside of the left front bumper trim.

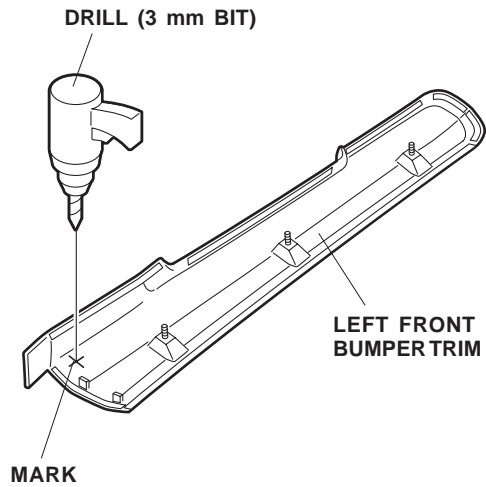

12. Using a 2 in. (51 mm) hole saw, drill through the hole you just made from the outer surface side of the left front bumper trim. Remove all burrs from the edges of the hole with a file, and apply touch up paint. Allow the touch-up paint to dry before proceeding to the next step.

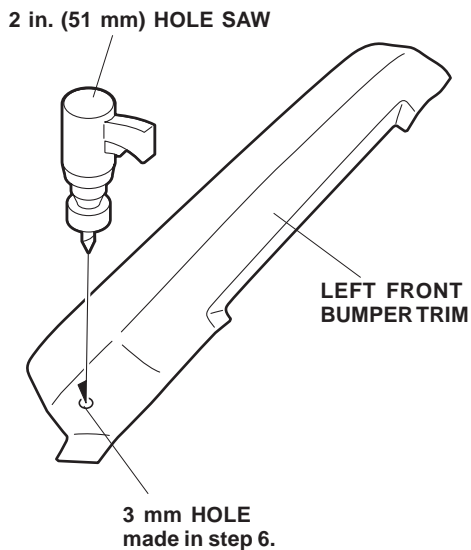

13. Remove the adhesive backing from the left front bumper trim, and attach one EPT sealer to the inside edge of the left front bumper trim.

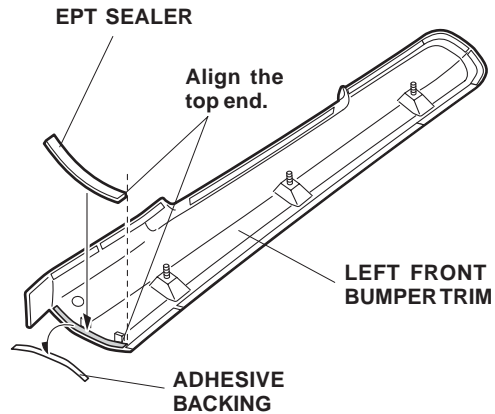

14. Repeat steps 11 thru 13 to mark and drill the right front bumper trim.
15. On the inside of the front bumper, locate the six marks for the outer front bumper trim. Center punch the six marked locations on the front bumper. While wearing eye protection, drill a 1 3/16 in. (30 mm) hole through the six marked locations.
 - First drill with a 3 mm drill bit, and finish with a 1 3/16 in. (30 mm) holesaw. Remove all burrs from the edges of the holes with a file.

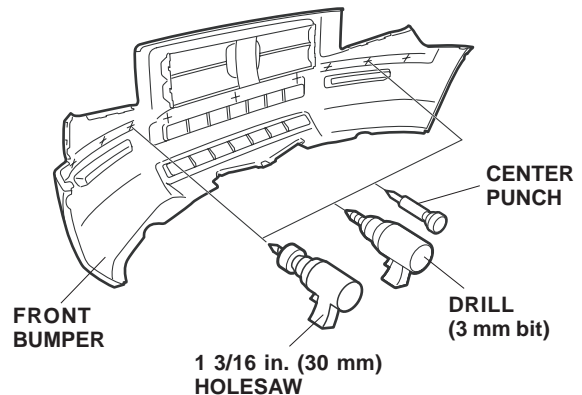

- On the back of the left front bumper trim, peel back 1 1/2 to 2 in. (3-5 cm) of each adhesive backing, and attach it to the front of the trim with masking tape.

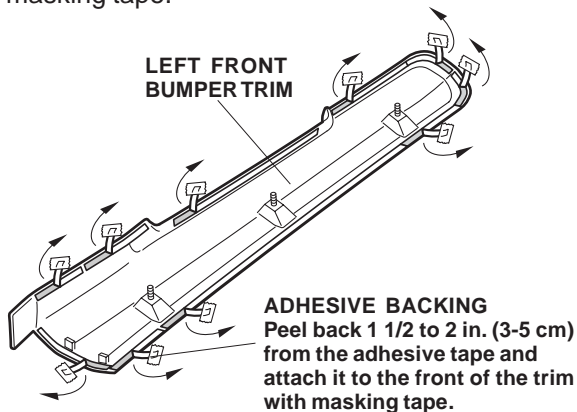

- Using isopropyl alcohol on a shop towel, clean the areas where the left front bumper trim will attach.
- Position the left front bumper trim on the front bumper, and install three brackets and three nuts as shown. Make sure the tab from the center front bumper trim is between the two retaining tabs on the left front bumper trim (if installed). Do not tighten the nuts at this time.

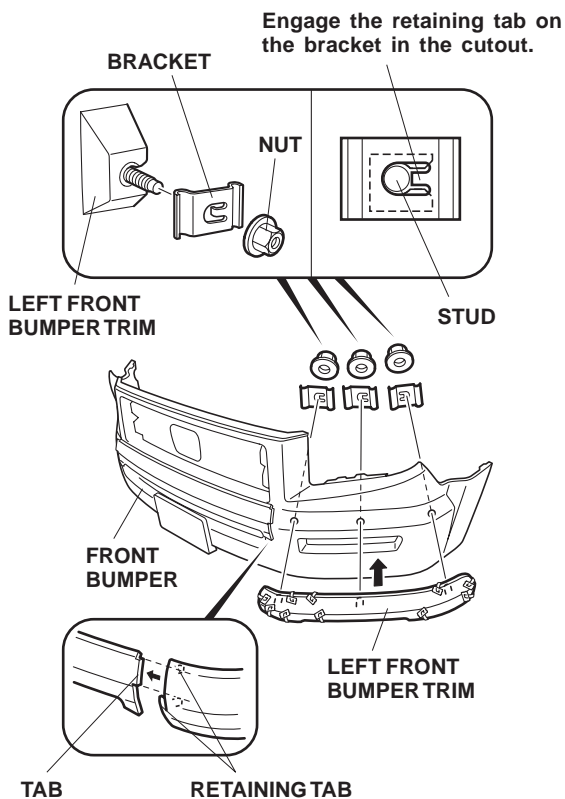

- While holding light pressure on the trim, carefully remove the adhesive backings from the trim. After removing the adhesive backings, hold the trim firmly against the front bumper with the palm of your hand for 30 seconds.

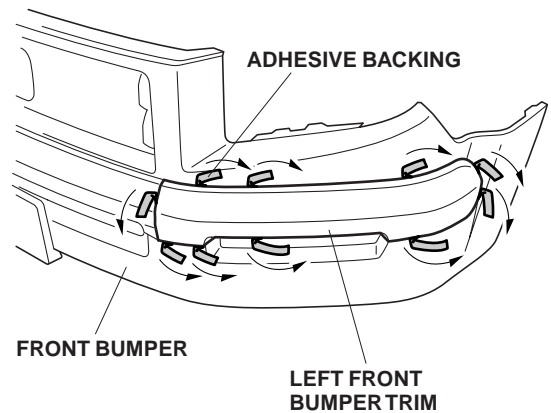

- Tighten the three nuts.
- Repeat steps 16 thru 20 to install the right front bumper trim.
- Reinstall the front bumper. Check that all retaining clips are installed properly.

Installing the Rear Bumper Trim

23. Open the tailgate.
24. Remove the left rear taillight. Remove two bolts, and pull the left taillight out toward you to release two clips and release the connector. Unplug the vehicle connector, and remove the left taillight.

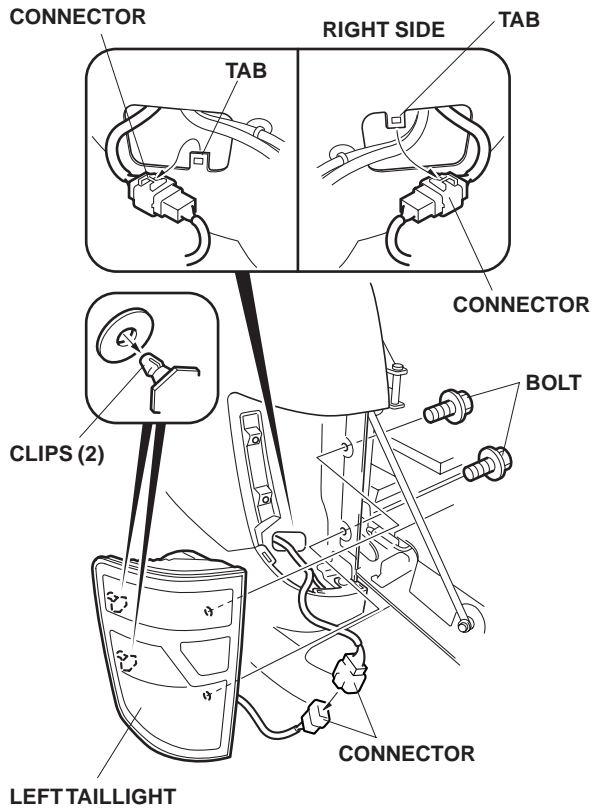

25. Remove the rear bumper:

- Remove the license plate (two bolts).
- Remove the two bolts, ten self-tapping screws and six clips from the bumper.
- With the help of an assistant, pull the bumper out toward you, unplug the two connectors and remove the bumper.
- Set the rear bumper on a blanket.

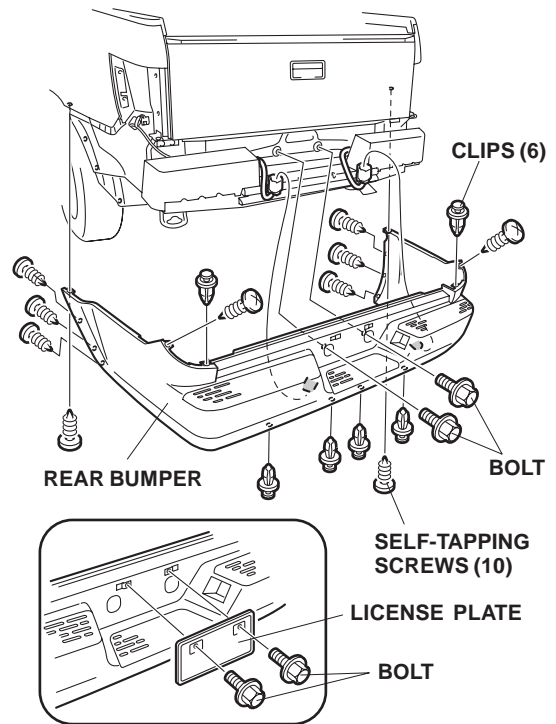

26. On the inside of the rear bumper, locate the six marks. Center punch the six marked locations on the rear bumper. While wearing eye protection, drill a 1 3/16 in. (30 mm) hole through each marked location. First drill with a 3 mm drill bit, and then finish with a 1 3/16 in. (30 mm) holesaw. Remove all burrs from the edges of the holes with a file.

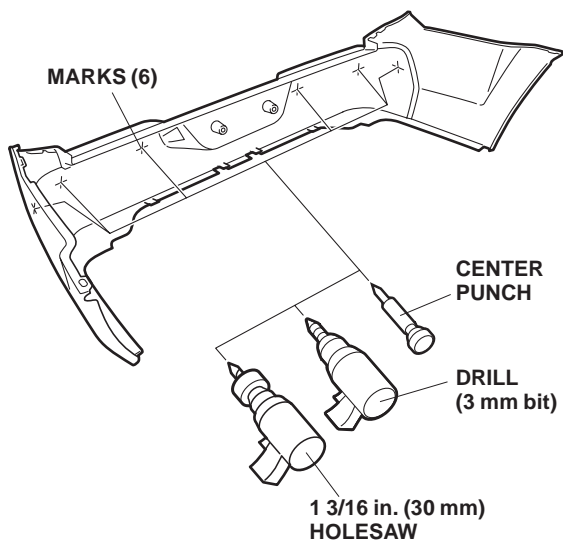

27. Measure 9 mm down from the top outside edge on the left side of the rear bumper, and mark the rear bumper with masking tape.

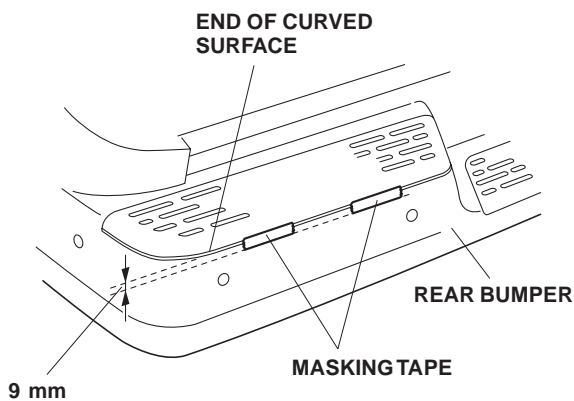

28. On the back of the left rear bumper trim, peel back 1 1/2 to 2 in. (3-5 cm) from each adhesive backing, and tape it to the front of the trim.

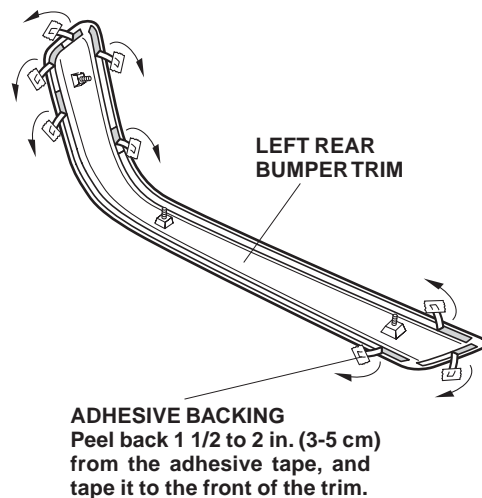

29. Using isopropyl alcohol on a shop towel, clean the areas where the left rear bumper trim will attach.
30. Position the left rear bumper trim on the rear bumper, and install three brackets and three nuts as shown. Do not tighten the nuts at this time.

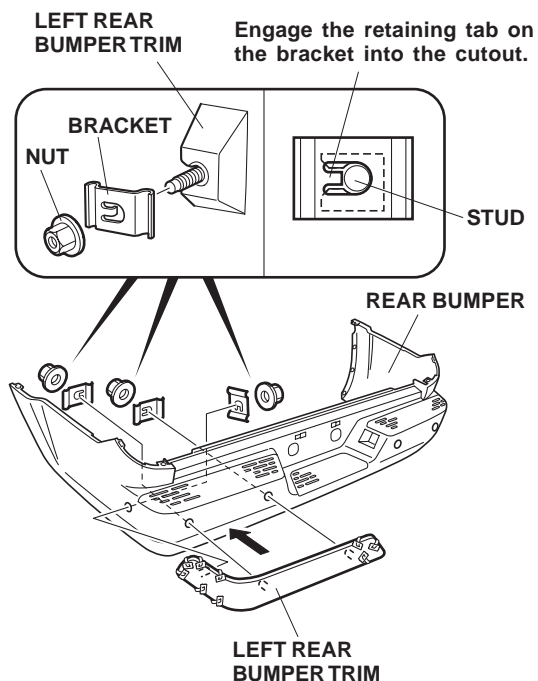

31. Align the upper line of the bumper trim with the masking tape. While holding light pressure on the trim, carefully remove the adhesive backings from the trim. After removing the adhesive backings, hold the trim firmly against the rear bumper with the palm of your hand for 30 seconds.

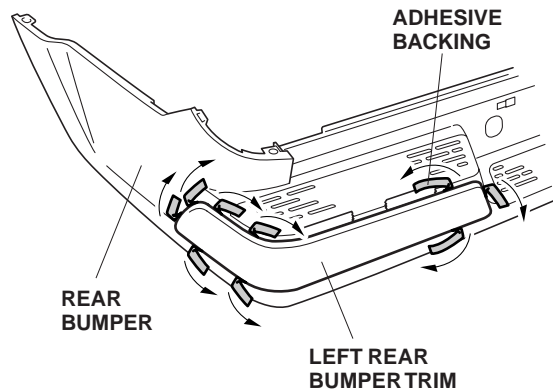

32. Tighten the three nuts.
33. Repeat steps 27 thru 32 to install the right rear bumper trim.
34. Reinstall all removed parts. Check that all retaining tabs and clips are installed properly.
35. Check that all wire harnesses are routed properly and all connectors are plugged in.
36. Reconnect the negative cable to the battery.
37. Reset the clock, and reset the radio station presets.

NOTE: Whenever the battery is disconnected, the driver's window AUTO function is disabled.

38. Start the engine. Push down on the driver's window switch until the window is fully open.
39. Pull up on the driver's window switch to close the window completely, then hold the switch for 2 seconds or more.
40. Lower and raise the window to check the operation of the driver's window AUTO function.