



INSTALLATION INSTRUCTIONS

Accessory
DVD in-VEHICLE ENTERTAINMENT SYSTEM WITH SUNROOF

Application
RIDGELINE

Publications No.
All 28609
 Issue Date
FEB 2005

PARTS LIST

**Attachment Kit:
 P/N 08B23-SJC-100**

i-VES harness

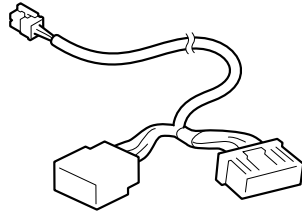

DIN cable "A"

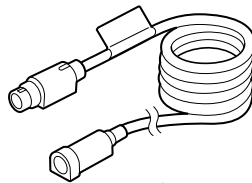

DIN cable "B"

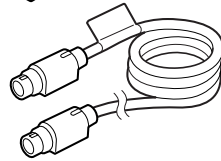

Interior light harness

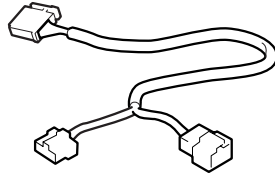

Sub-feeder cord

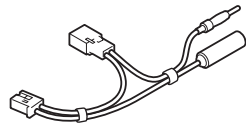

Monitor gasket

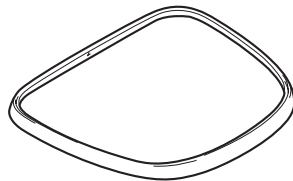

Monitor bracket

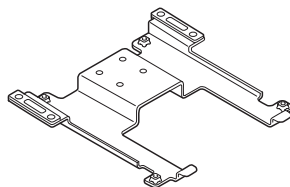

DVD player bracket A

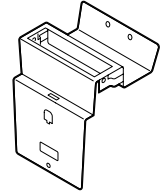

DVD player bracket B

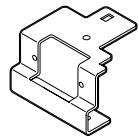

FM modulator bracket

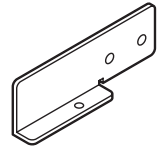

Template: without sunroof
 (Not used.)

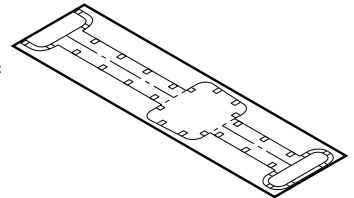

Template: with sunroof

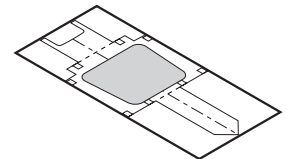

Template A

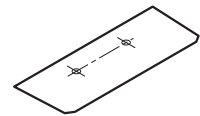

Template B

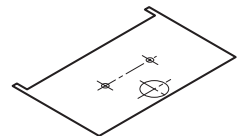

2 Screws, 3 x 8 mm



Washer-screw, 5 x 12 mm



2 Washer-screws, 5 x 16 mm



2 Washer-screws, 5 x 25 mm



4 Washer-screws, 6 x 12 mm
(Not used.)



4 Stepped bolts, 5 mm



4 Square-head bolts



4 Flange nuts, 4 mm



Flange nut, 5 mm



2 Cap nuts, 5 mm



2 Nuts, 3 mm



Connector clip



18 Wire ties

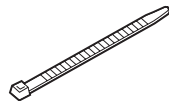

Long wire tie

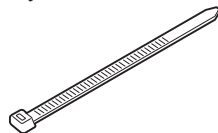

10 Cushion tapes

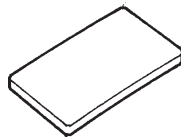

7 EPT sealers

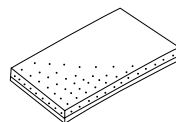

**Monitor Kit (sold separately):
P/N 08A23-2G1-010**

Monitor console

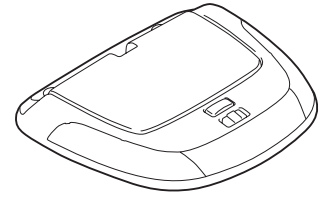

DVD player

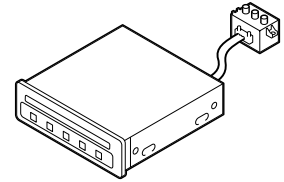

2 Headphones



Remote controller

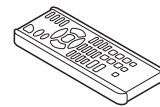

FM modulator

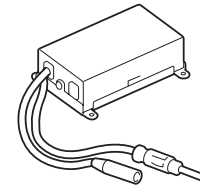

4 Washer-screws, 5 x 8 mm



2 Screw caps



Quick Reference Tag

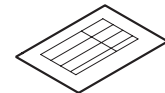

Owner's Manual

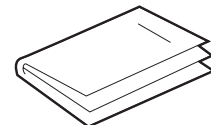

TOOL AND SUPPLIES REQUIRED

Phillips screwdriver
Flat-tip screwdriver
Utility knife
Scissors
Push-pin
Isopropyl alcohol
Shop towel
Tape measure
Drill
3 mm and 8 mm Drill bits
1-1/8" (28 mm) Hole saw
Ratchet
5 mm, 8mm, and 10 mm Combination wrenches
8 mm, 10 mm, and 14 mm Sockets
Tape
Masking tape
Torque wrench
T25 Torx wrench
Diagonal cutters
Eye protection (face shield, safety goggles, etc.)

Illustration of the DVD *i*-VES installed in the Vehicle

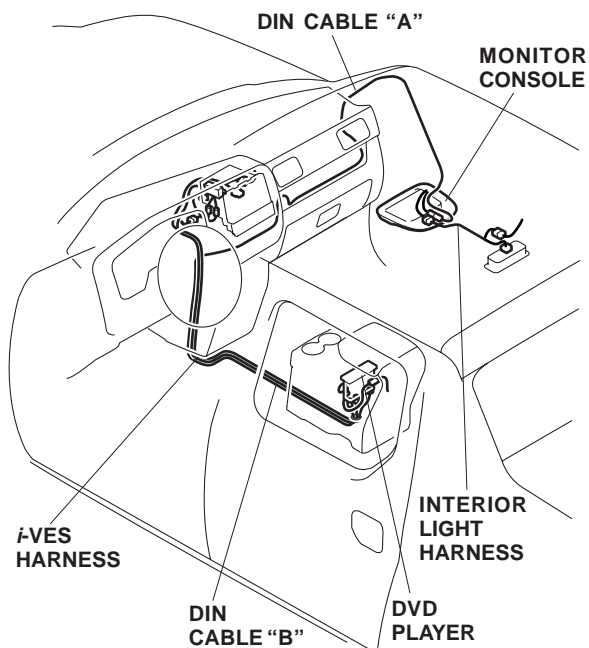

INSTALLATION

Customer Information: The information in this installation instruction is intended for use only by skilled technicians who have the proper tools, equipment, and training to correctly and safely add equipment to your vehicle. These procedures should not be attempted by "do-it-yourselfers."

1. Make sure you have the anti-theft code for the radio, then write down the radio station presets.
2. Close the sunroof.
3. Disconnect the negative cable from the battery.
4. Insert a flat-tip screwdriver wrapped with a shop towel into the groove of the instrument panel and release two clips. Pull the instrument panel out toward you to release eighteen clips, and remove the instrument panel by unplugging the vehicle connectors.

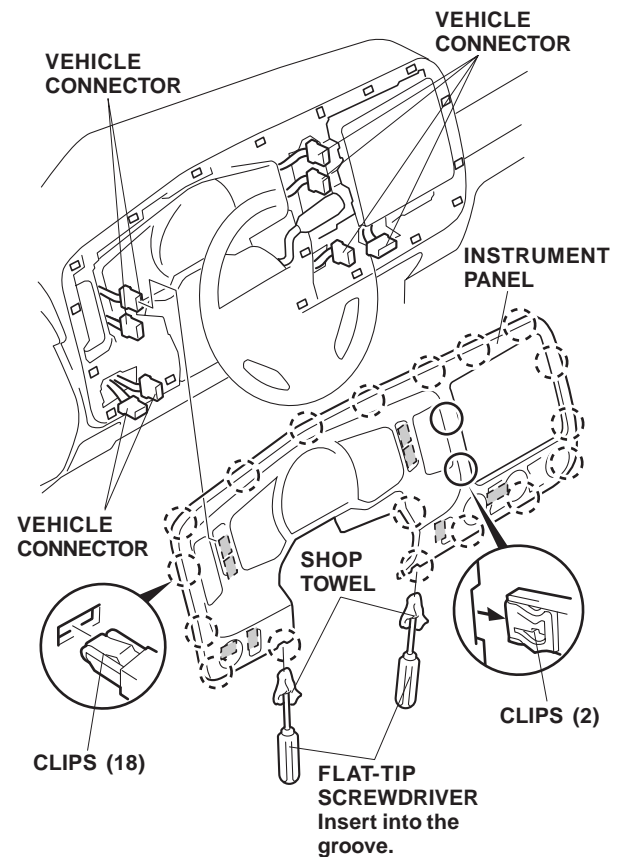

- Remove the audio unit (five screws, and pull the audio unit out toward you, and unplug the vehicle connectors).

Without Navi

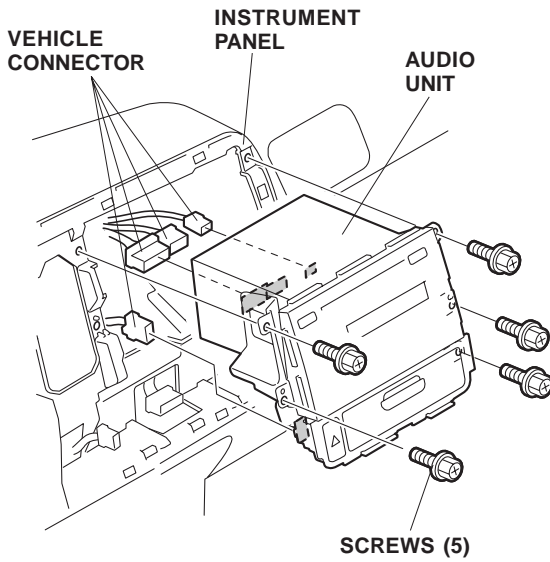

With Navi

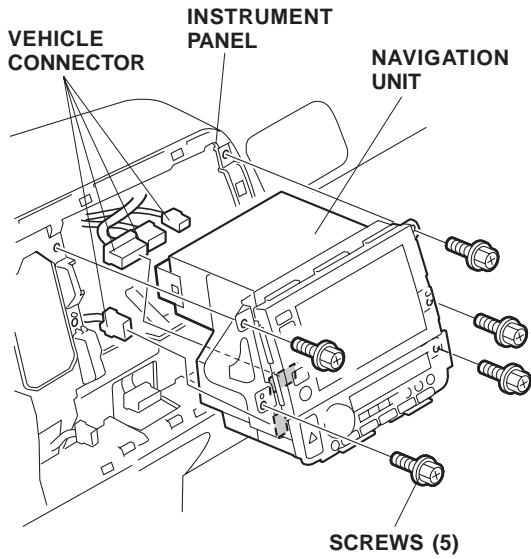

- Remove the driver's console side trim (three retaining clips and one tab).

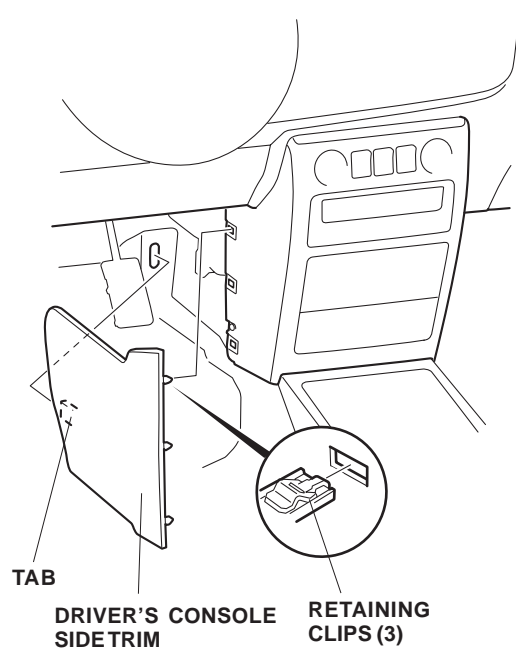

- Remove the passenger's console side trim (two retaining clips and one tab).

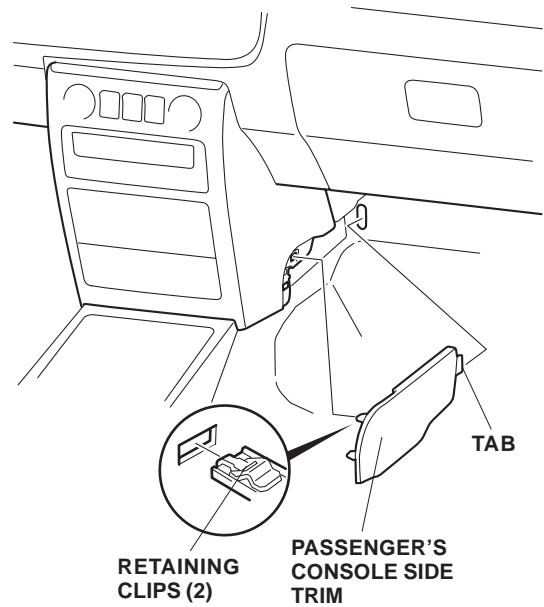

8. Remove the dashboard center lower cover:

- Remove the center pocket.
- Remove the three self-tapping screws.
- Release the five retaining clips and six retaining tabs, and pull out the dashboard center lower cover.
- Unplug the vehicle connectors, and remove the dashboard center lower cover.

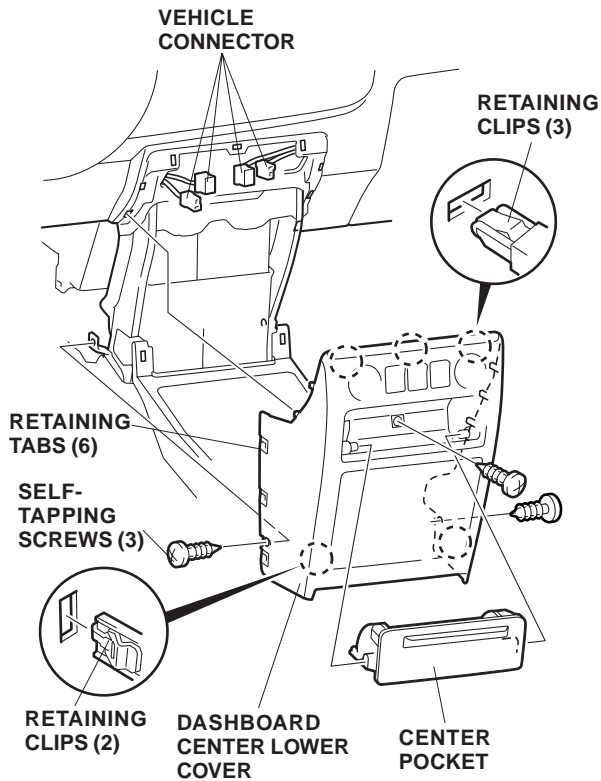

9. Remove the glove box:

- Open the glove box. Disconnect the damper arm.
- Remove the stoppers (two retaining tabs for each stopper).
- Remove the two screws.

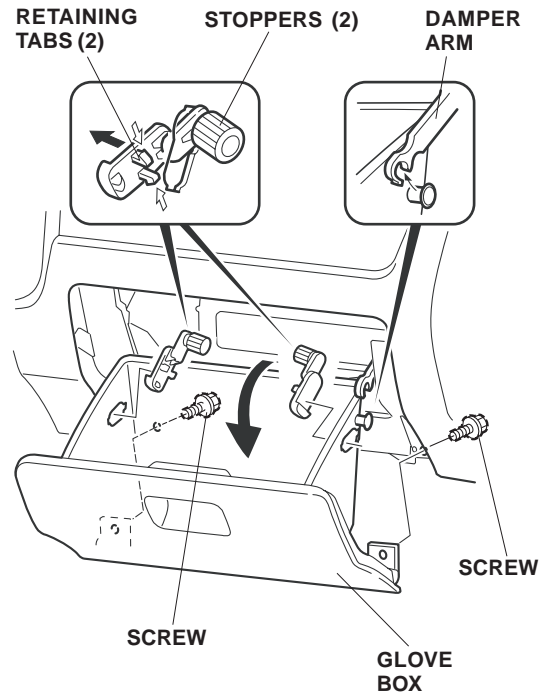

10. Remove the right dashboard side cover (seven clips).

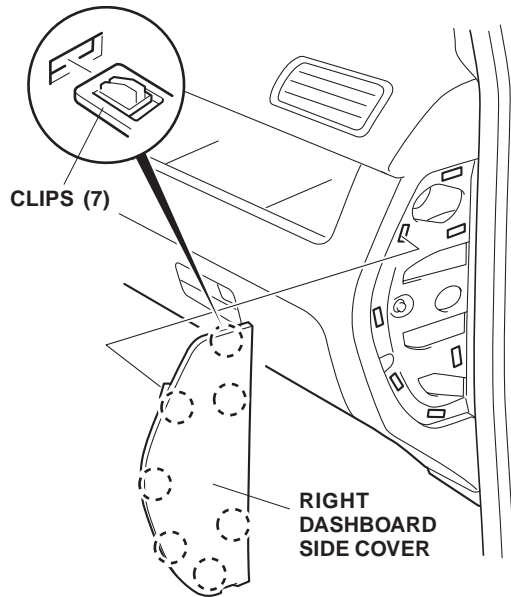

11. Remove the front center tray (two clips and two hooks).

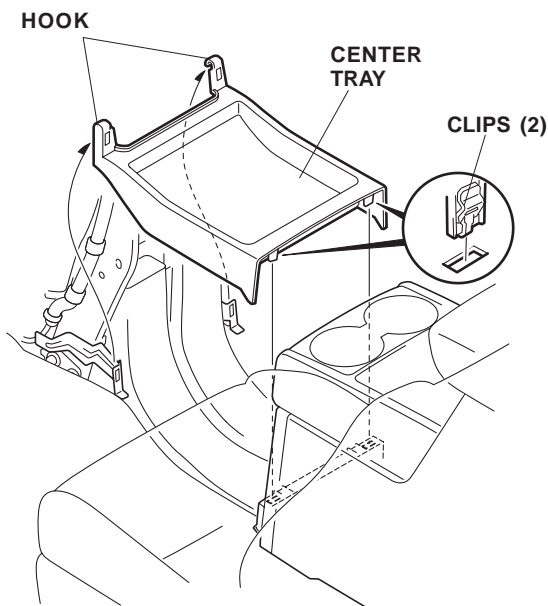

12. Remove the center console rear cover :

- Pull the center console rear cover out toward you to release eight clips.
- Slide the vehicle console light connector and the vehicle connector, and remove the vehicle console light connector and the vehicle connector from the vehicle clips.
- Unplug the vehicle console light connector and the vehicle connector.

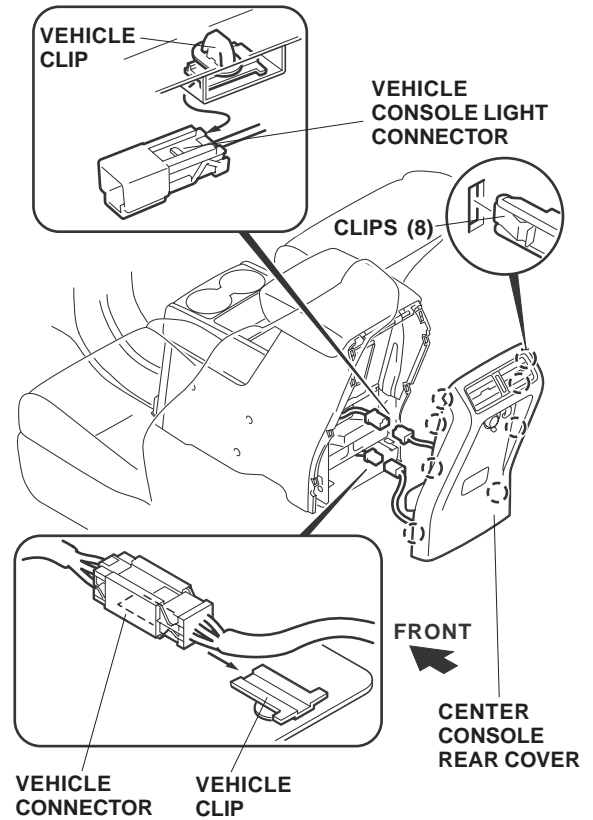

13. Remove the vehicle console light and harness (two retaining tabs).

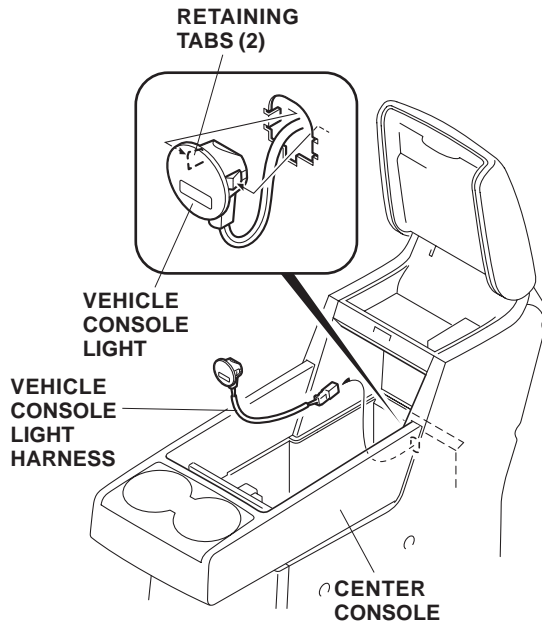

14. Remove the center console (two bolts and two self-tapping screws).

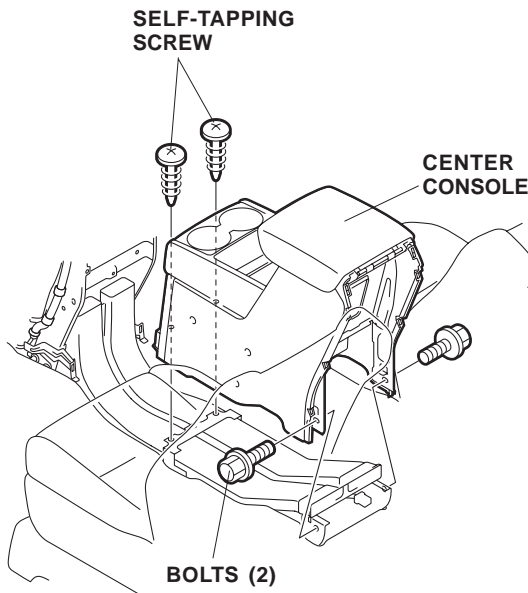

15. Remove the right front door sill trim (three clips and three retaining tabs).

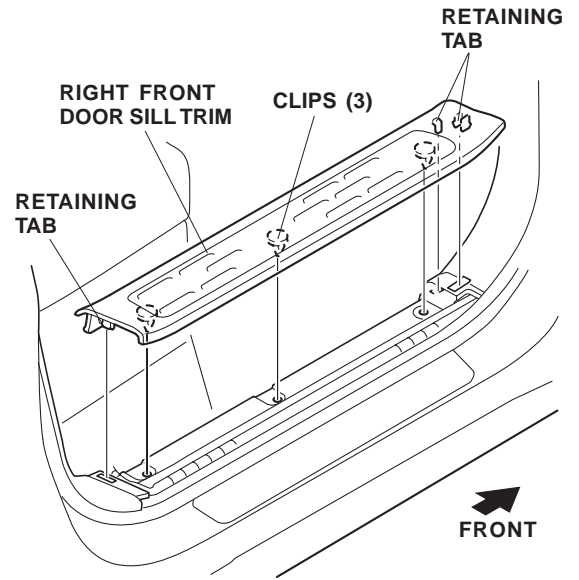

16. Remove the right rear door sill trim (three clips and three retaining tabs).

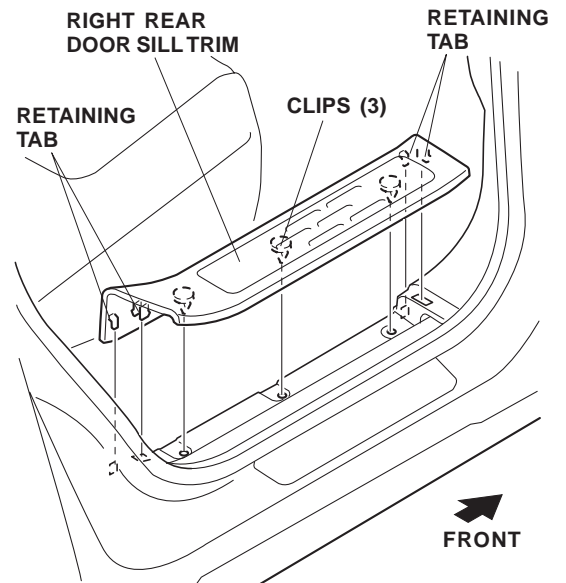

17. Pull away the weatherstrip from the B-pillar lower trim panel. Remove the right seat belt lower anchor bolt cover and remove the right seat belt lower anchor bolt. Remove the right B-pillar lower trim panel by pulling it out toward you as shown.

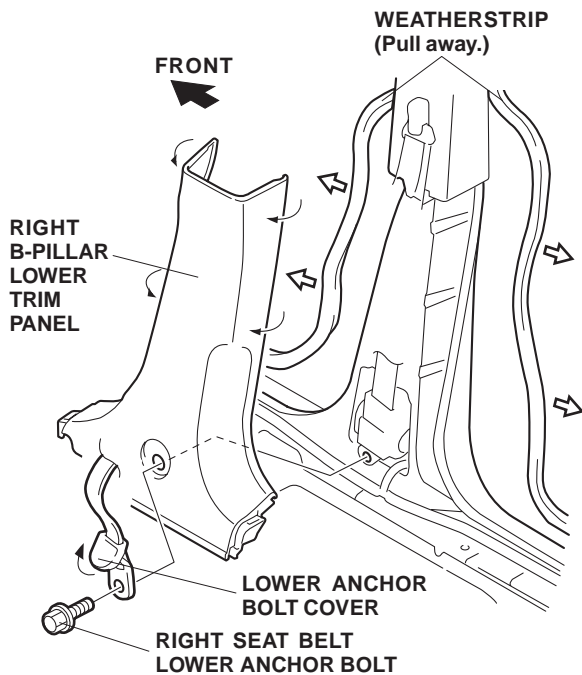

18. Remove the right seat belt upper anchor bolt cover (four retaining tabs). Remove the right front seat belt upper anchor bolt.

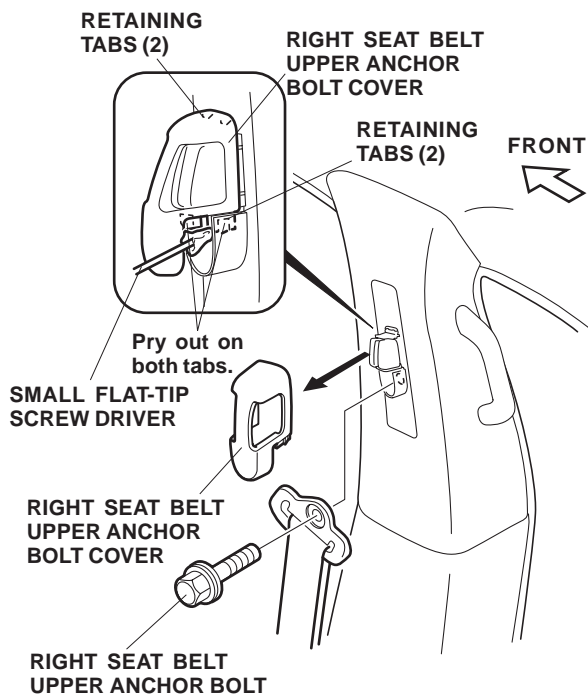

19. Remove the right rear grab rail screw covers (two retaining tabs for each cover). Remove the right rear grab rail (two screws).

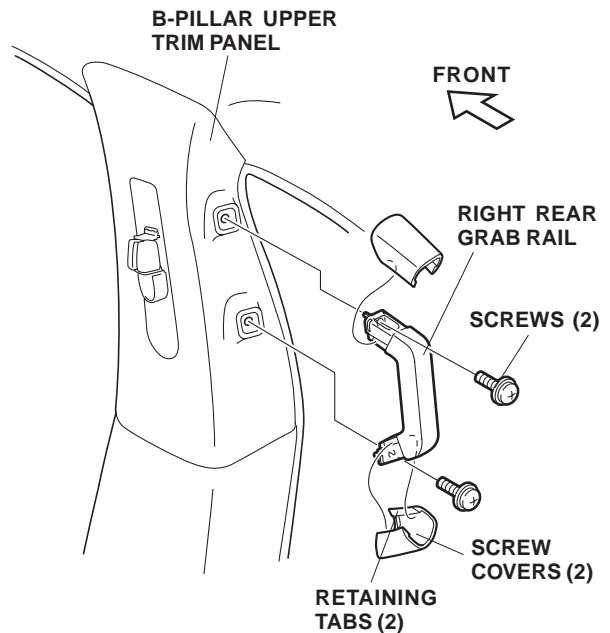

20. Pull away the weatherstrip from the right B-pillar upper trim panel. Remove the right B-pillar upper trim panel (two clips).

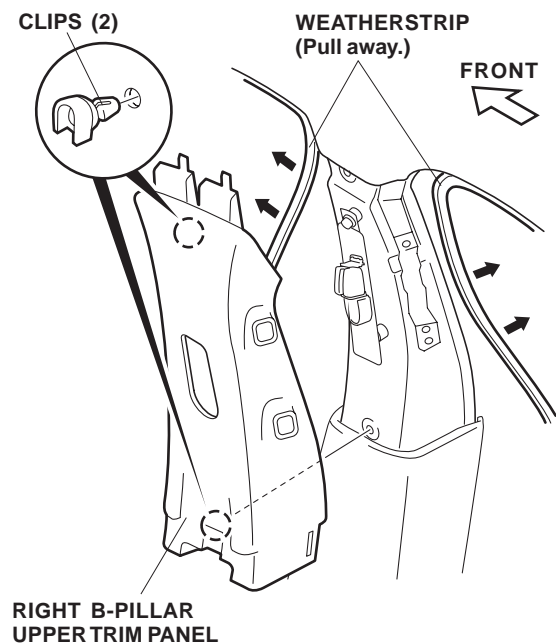

- Remove the right rear hook trim cover (four tabs). Remove the right rear hook trim (two self-tapping screws).

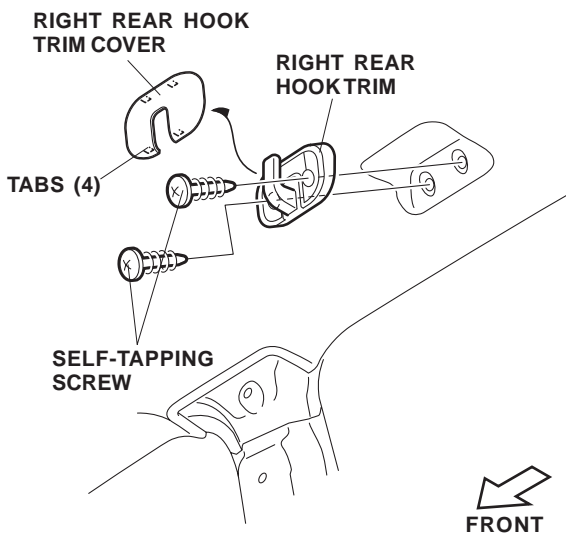

- Remove the passenger's grab rail screw covers (two retaining tabs for each cover), then remove the passenger's grab rail (two screws).

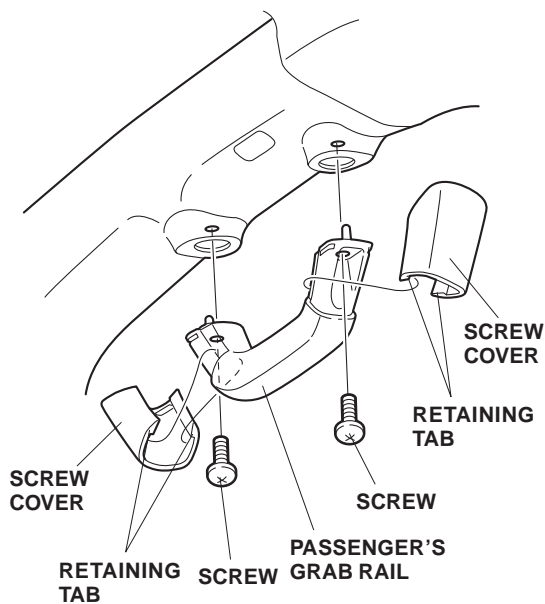

- Pull away the weatherstrip away from the passenger's A-pillar. Remove the passenger's A-pillar trim (two clips).

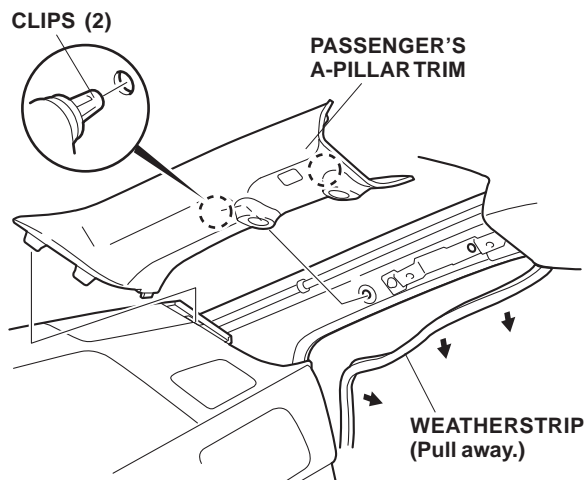

- Remove the left and right lenses from the roof console (four retaining tabs for each lens).

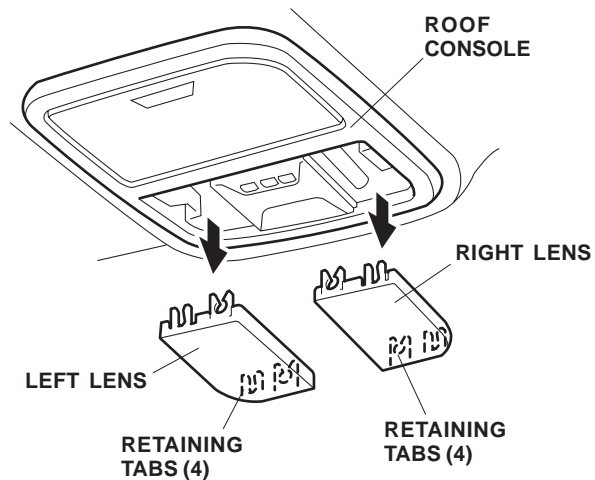

25. Open the console pocket lid and remove the four bolts. Unplug two vehicle connectors, and remove the roof console.

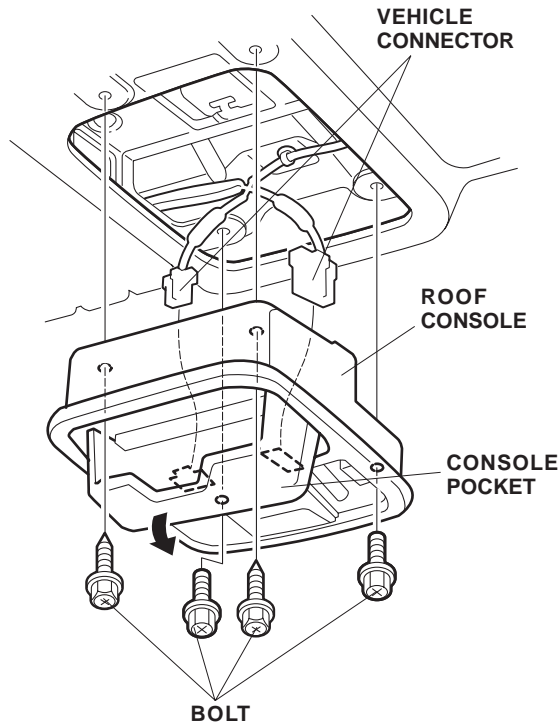

26. Remove the sunvisor holders by rotating them clockwise.

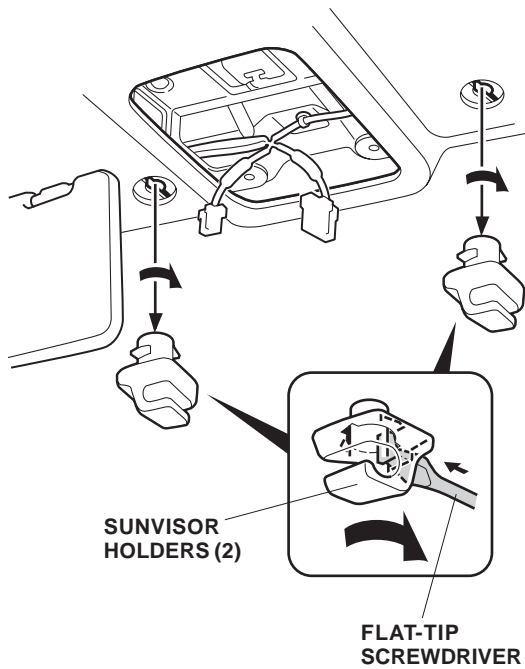

27. Remove the right sunvisor screw cover (four retaining tabs), and remove the right sunvisor (two torx screws and unplug the vehicle connector).

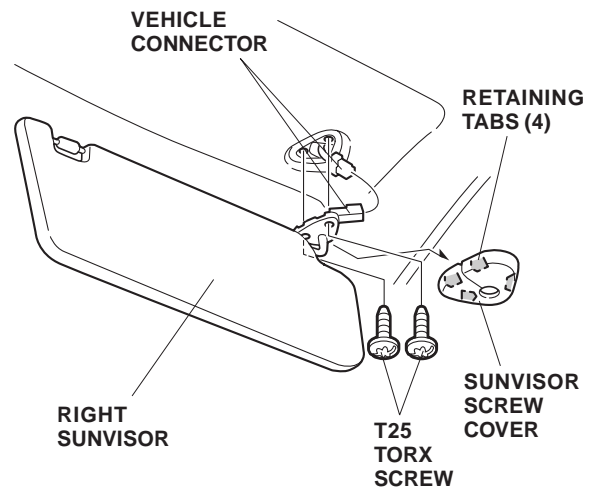

28. Using scissors, cut out the marked area from the template (with sunroof). Crease the template as shown.

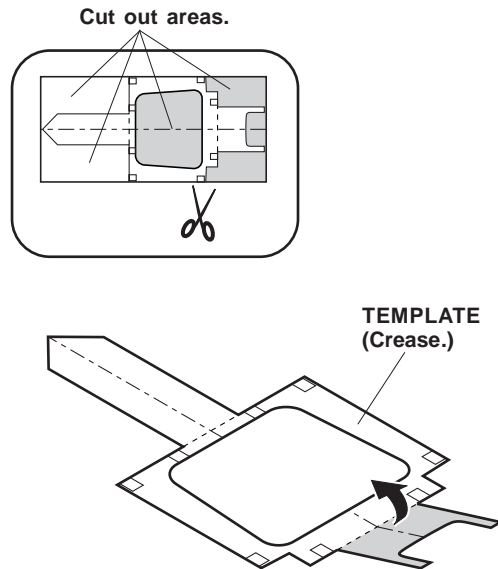

29. Open the sunshade. Position the template on the headliner and align the cutout with the sunshade knob. Tape the template to the headliner using strips of masking tape.

NOTE: Template is positioned with sunroof closed and sunshade open.

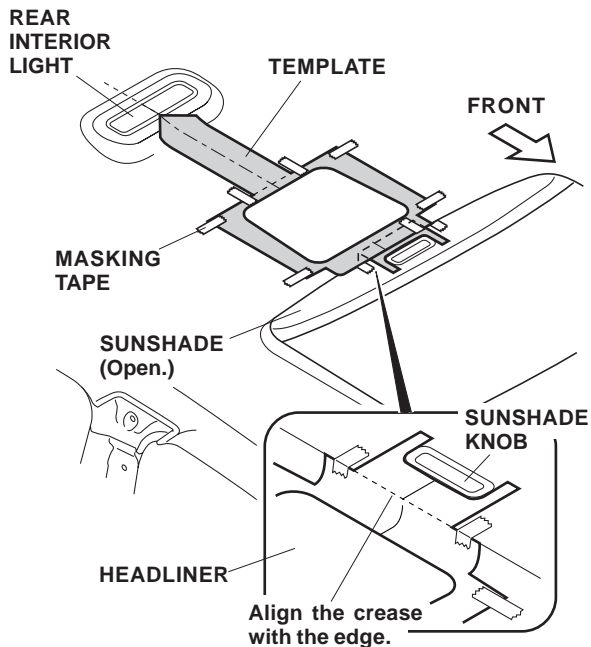

30. Using a felt-tip pen, mark the headliner along the outer edges of the template. Remove the template.

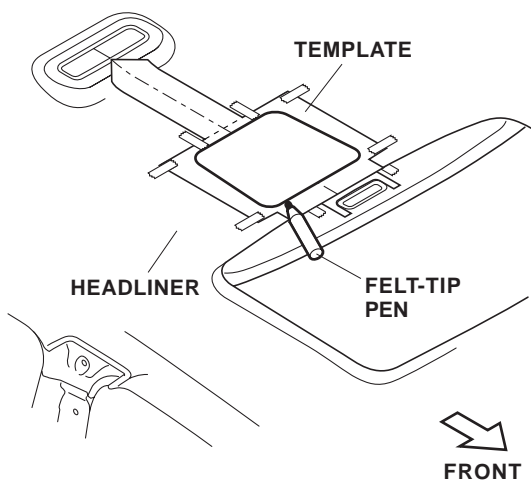

31. Close the sunshade.

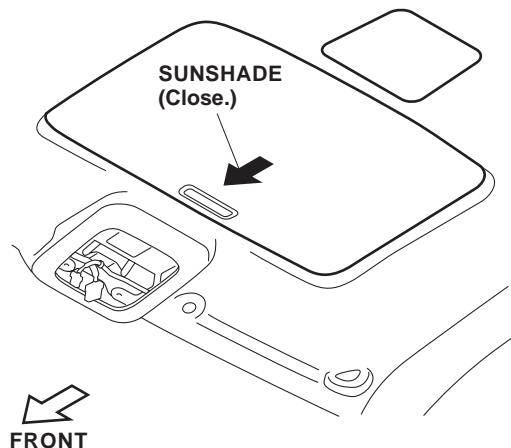

32. Using a utility knife, cut out the marked area of the headliner.

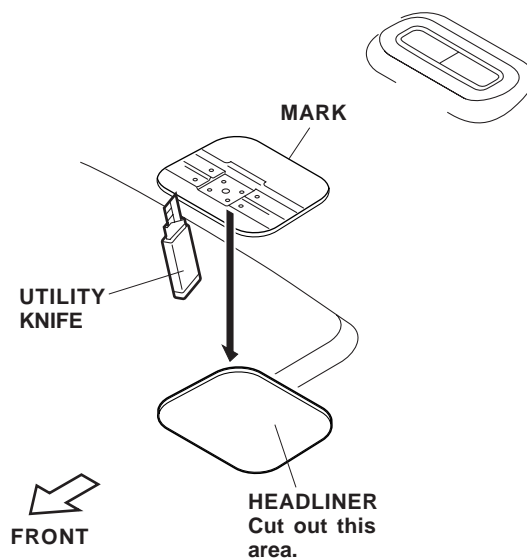

33. Gently pull the headliner down to release three clips and five velcro fasteners.

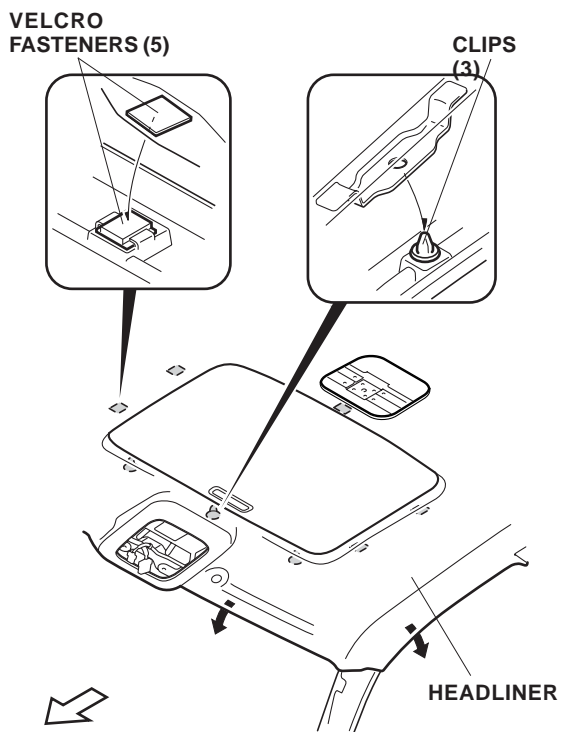

34. Route DIN cable "A" up through the headliner from the passenger's A-pillar, and out through the opening in the headliner you made in step 32.

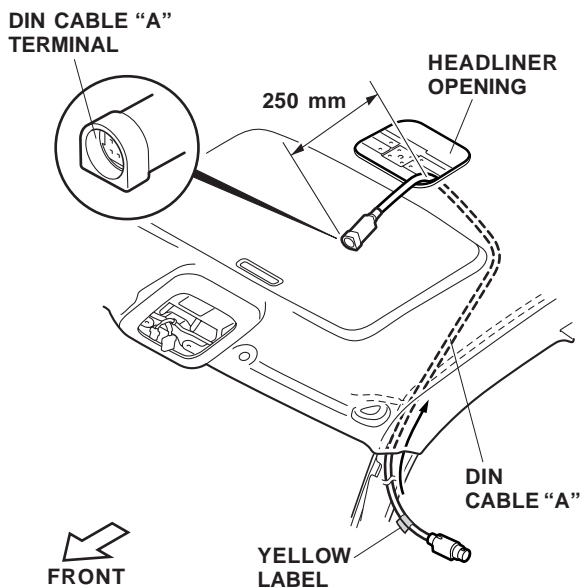

35. Route the yellow label side of DIN cable "A" along the vehicle harness, and temporarily secure DIN cable "A" to the vehicle harness with one wire tie.

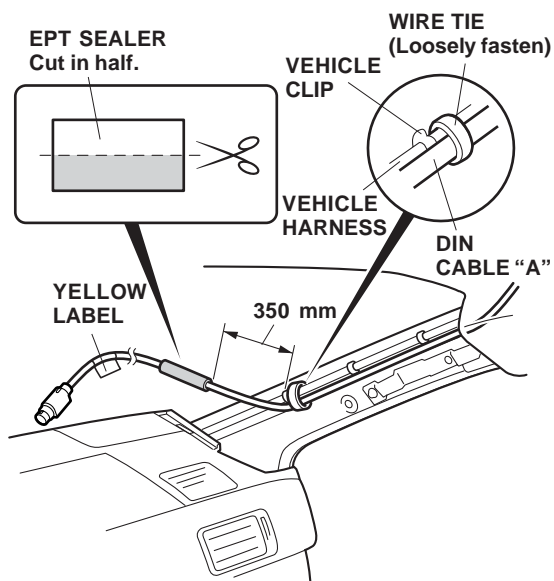

36. Using isopropyl alcohol on a shop towel, clean the area where the EPT sealer will attach. Using scissors, cut one EPT sealer in half. Wrap the EPT sealer half to DIN cable "A" in the area shown.
37. Route DIN cable "A" down behind the dashboard and towards the glove box opening.

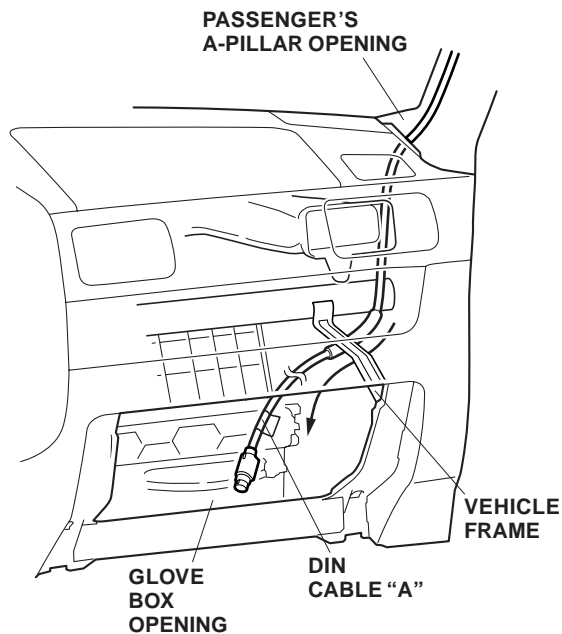

38. Inside the glove box opening, route DIN cable "A" along the vehicle harness and towards the driver's side of the vehicle.

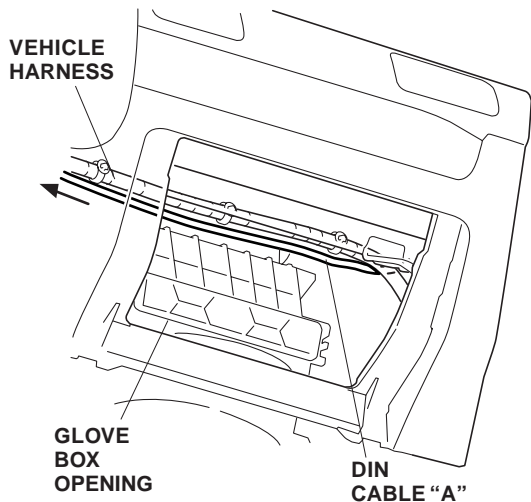

39. Route DIN cable "A" to the audio unit opening, and down towards the floor vehicle.

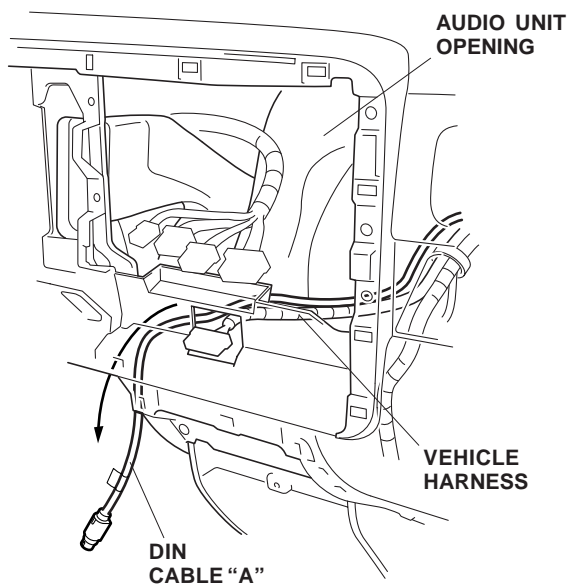

Routing the *i*-VES Harness and the DIN Cables

40. At the audio unit opening, route the *i*-VES harness and the white label end of DIN cable "B" along the vehicle harness from the audio unit opening toward the floor of the vehicle.

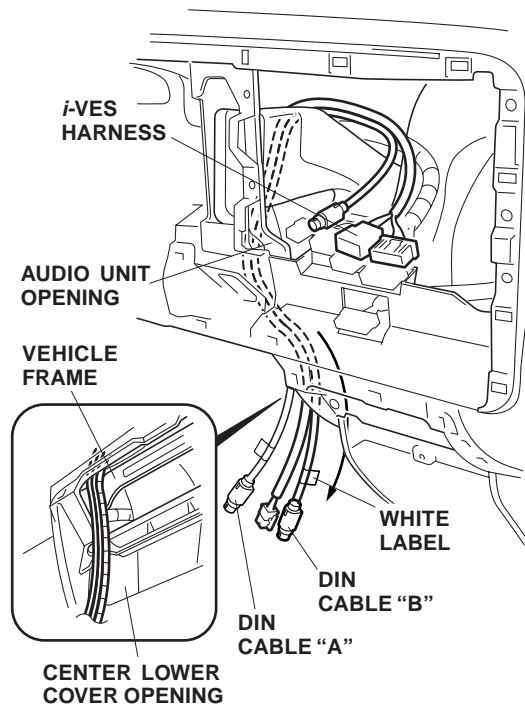

41. Route the *i*-VES harness, DIN cable "A" and DIN cable "B" toward the rear of the vehicle.

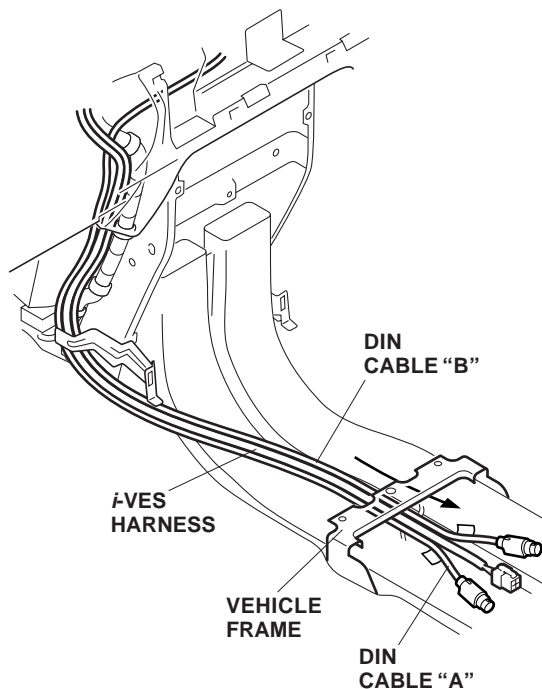

42. Slide the center console cup holder forward, and slide the inner cover forward. Open the console cover.

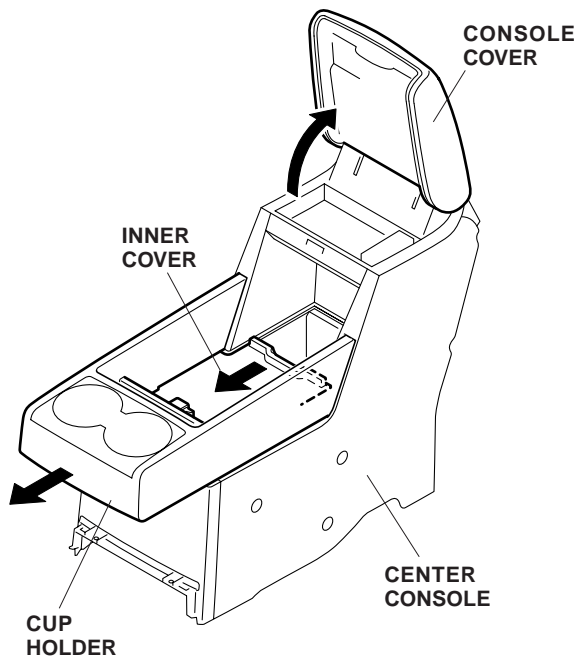

43. Position template A on the center console at the location shown, and attach template A to the center console using strips of tape.

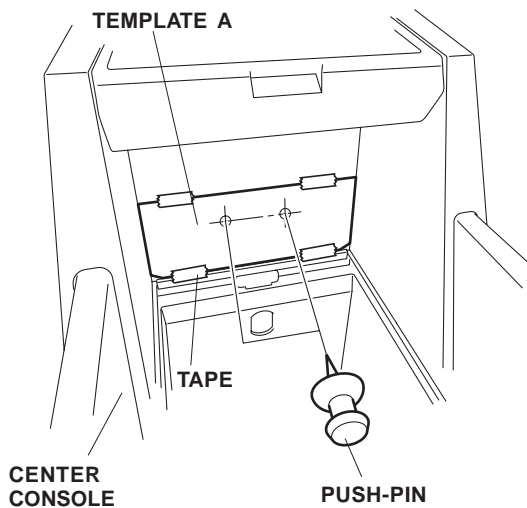

44. Using a push-pin, mark the center console at the marks on the template. Remove the template.

45. To prevent drilling through the inner panel, wrap tape around the end of a 3 mm and an 8 mm drill bit about 15-20 mm away from the tip.

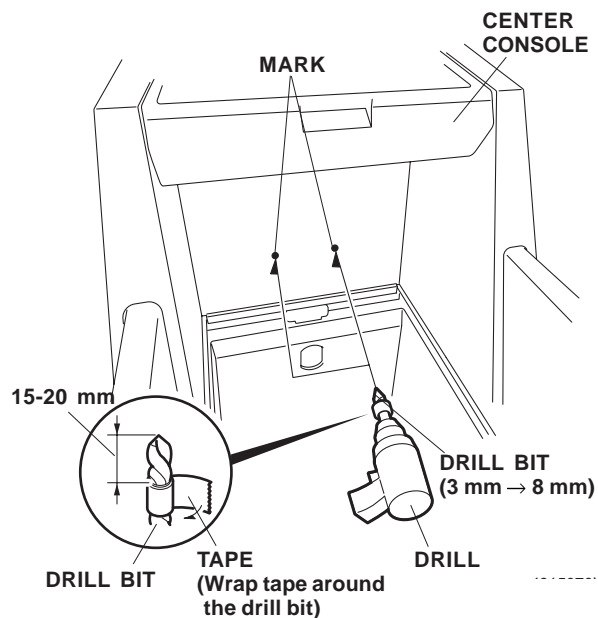

46. While wearing eye protection, drill an 8 mm hole at each marked point. Start with a 3 mm drill bit and finish with an 8 mm drill bit. Remove any burrs from each hole.

47. Position template B on the center console at the location shown, and tape the template to the center console.

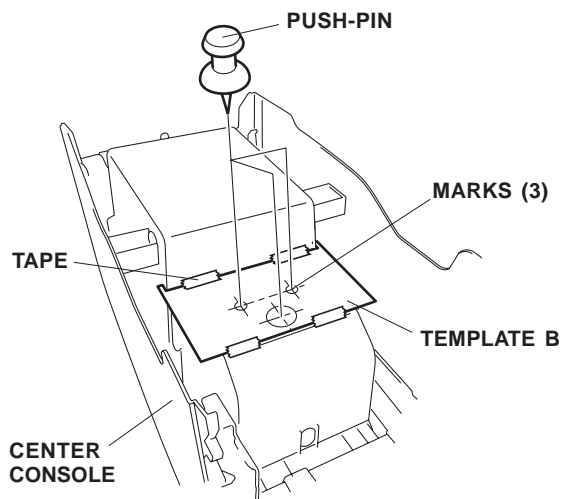

48. Using a push-pin, mark the center console at the marks on the template. Remove the template.

49. While wearing eye protection, drill an 8 mm hole at each marked point. Start with a 3 mm drill bit and finish with an 8 mm drill bit. Use the drill bit with the tape attached.

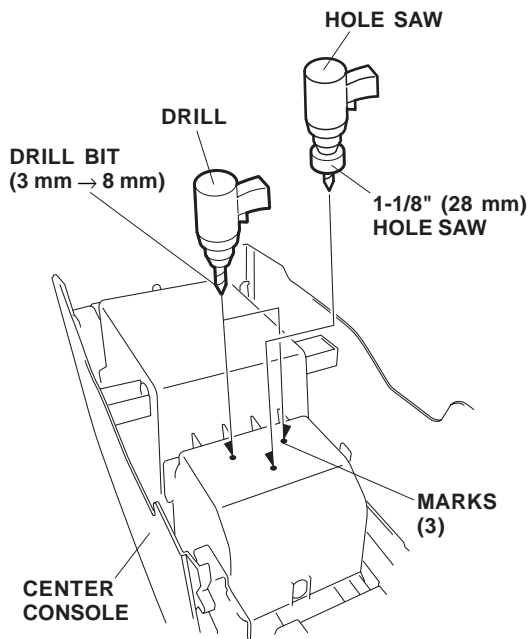

50. Using a 1-1/8" (28 mm) hole saw, enlarge the center 8 mm hole to 1-1/8" (28 mm). Remove any burrs from each hole.
51. Reposition the center console in place. Route the *i*-VES harness, and DIN cables "A" and "B" through the 28 mm hole.

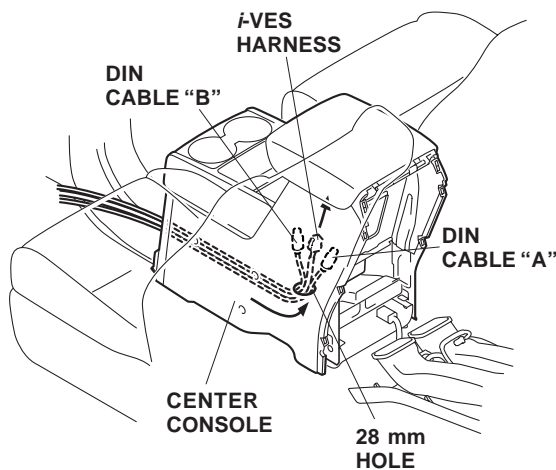

52. Plug in the vehicle connectors, and install the vehicle connector in the vehicle clip. Route the vehicle console light harness through the console light opening.

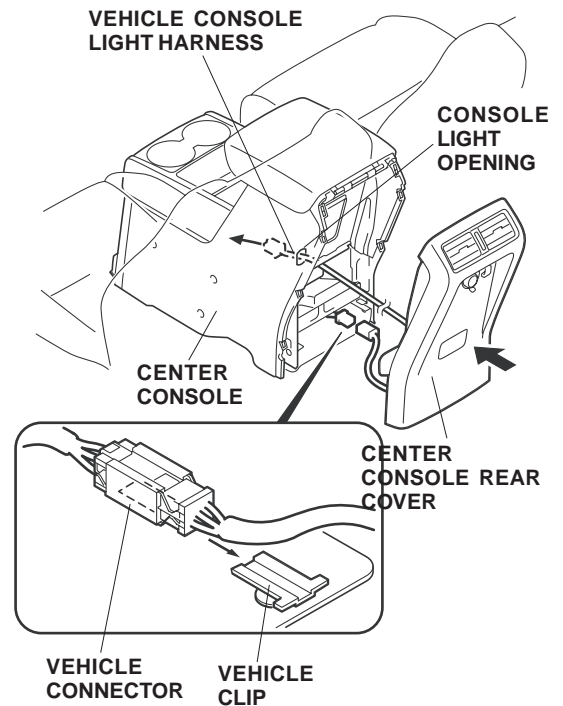

Installing the DVD Player

53. Slide the DVD player into DVD player bracket A.

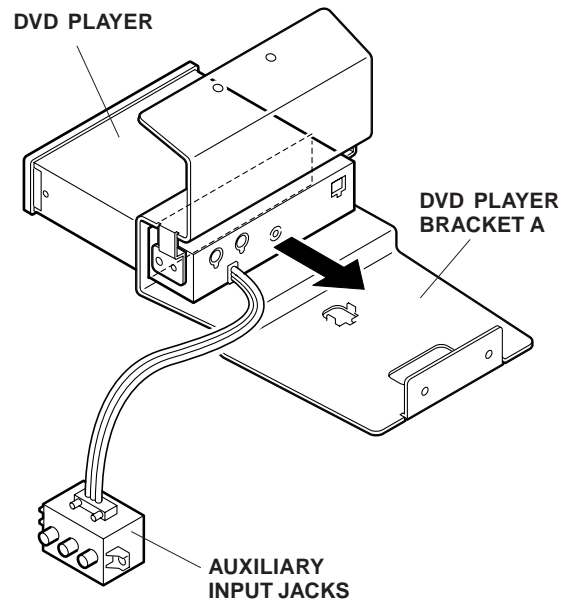

54. Secure the auxiliary input jacks from the DVD player to DVD player bracket B with two 3 x 8 mm screws and two 3 mm nuts.

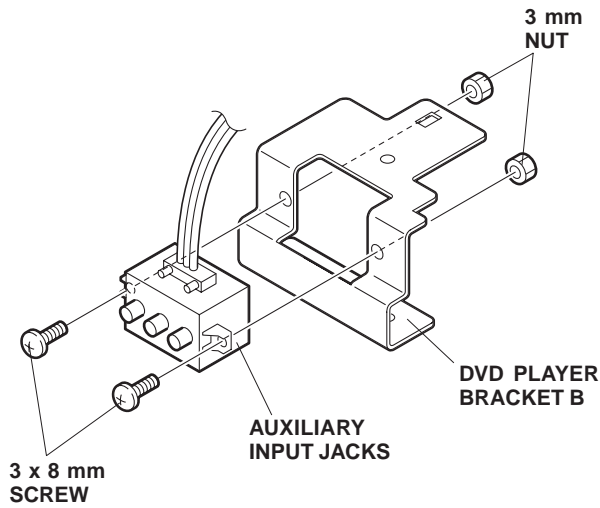

55. Secure DVD player bracket B to DVD player bracket A with one 5 x 12 mm washer-screw and one 5 mm flange nut.

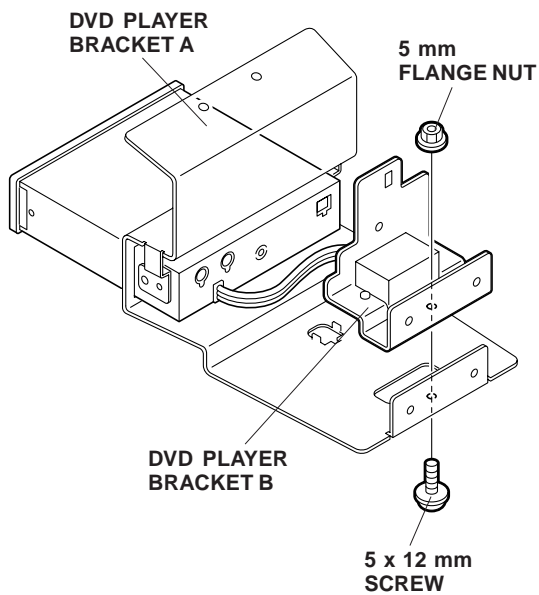

56. Install the vehicle console light to DVD player bracket A as shown.

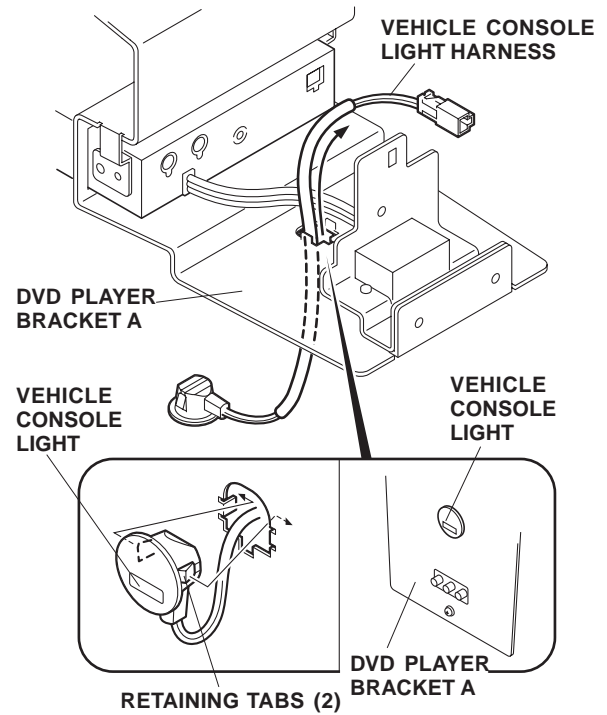

57. Secure the DVD player to DVD player bracket A and B with three 5 x 8 mm washer-screws included with the Monitor Kit.

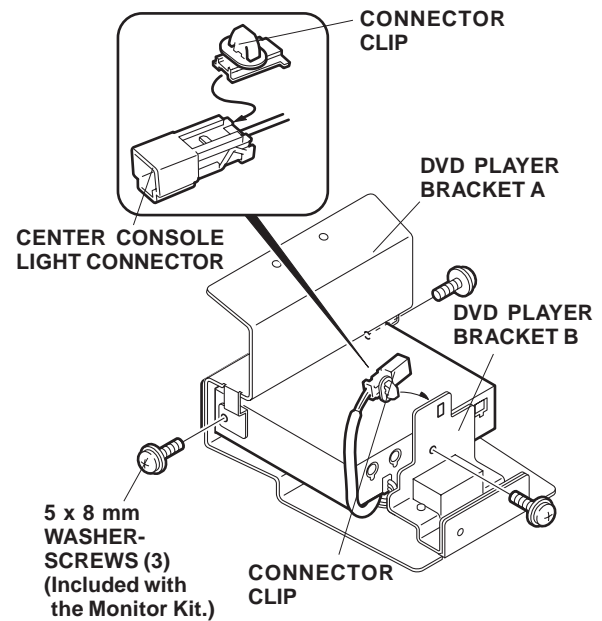

58. Install the connector clip to the vehicle console light connector, and secure the vehicle console light connector to DVD player bracket B.

59. Slide the DVD player into the center console.

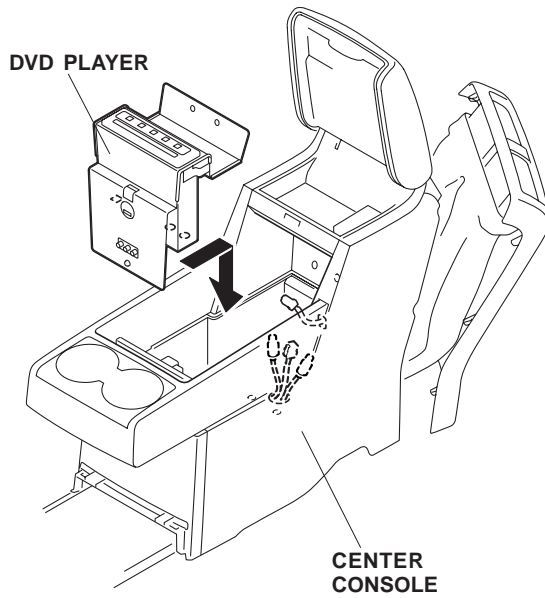

60. Plug the *i*-VES harness 4-pin connector, DIN cable "A" and "B" and the vehicle console light connector into the rear of the DVD player.

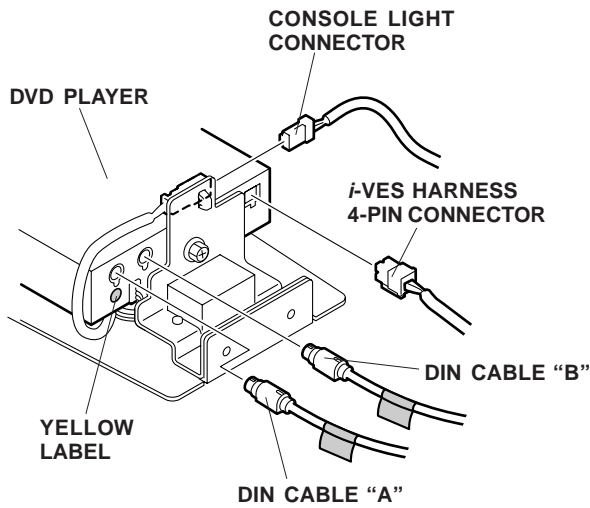

61. Secure DVD player bracket A to the center console with two 5 mm stepped bolts and two 5 mm cap nuts.

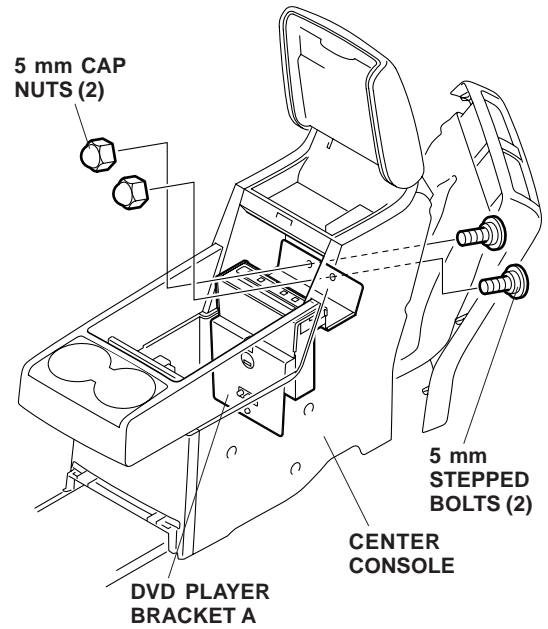

62. Lift the center console as shown, and secure DVD player bracket A to the center console with two 5 mm stepped bolts.

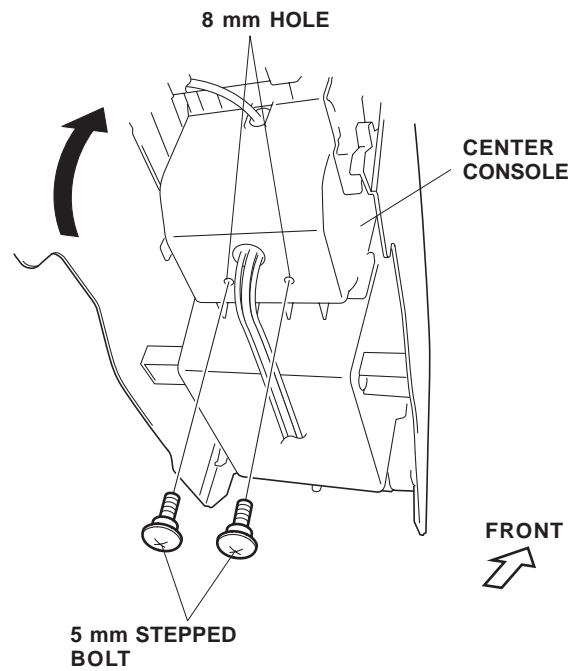

63. Using isopropyl alcohol on a shop towel, clean the areas where the cushion tapes will attach. Lift the center console, then secure the *i*-VES harness and the DIN cables to the vehicle panel with two cushion tapes as shown.

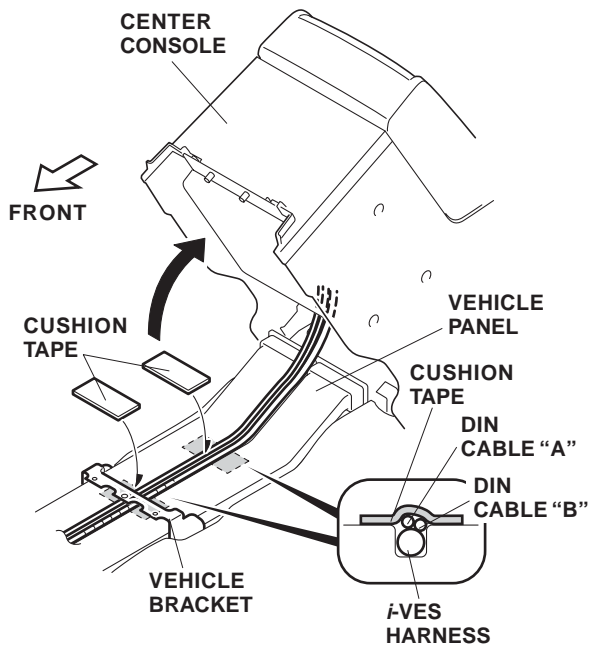

64. Reinstall the center console.

65. Pull back the floor carpet. Using isopropyl alcohol on a shop towel, clean the areas where the cushion tapes will attach. Secure the *i*-VES harness and the DIN cables to the vehicle panel with two cushion tapes as shown.

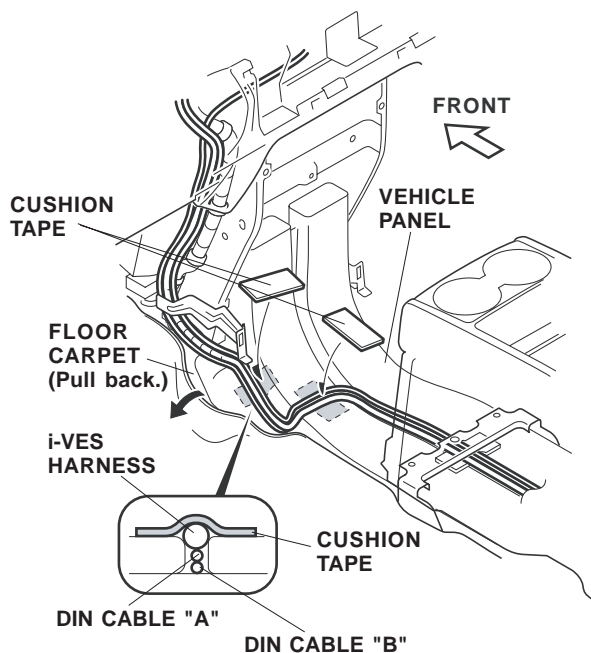

66. Secure the *i*-VES harness and the DIN cables to the vehicle harness with two wire ties in the areas shown.

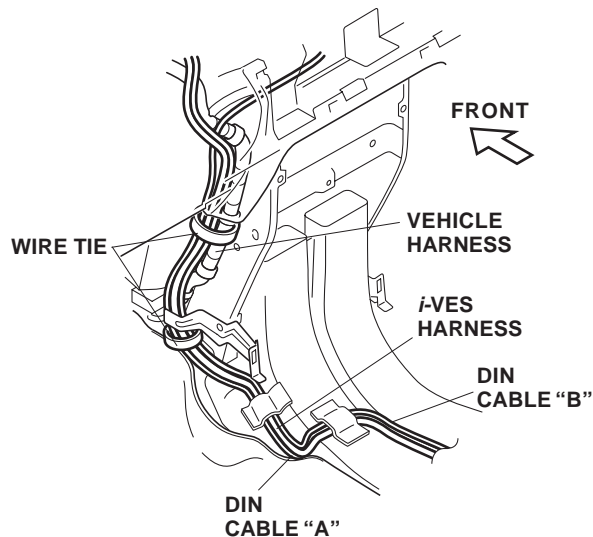

67. At the audio unit opening, secure the *i*-VES harness and DIN cable "B" to the vehicle harness with one wire tie in the area shown.

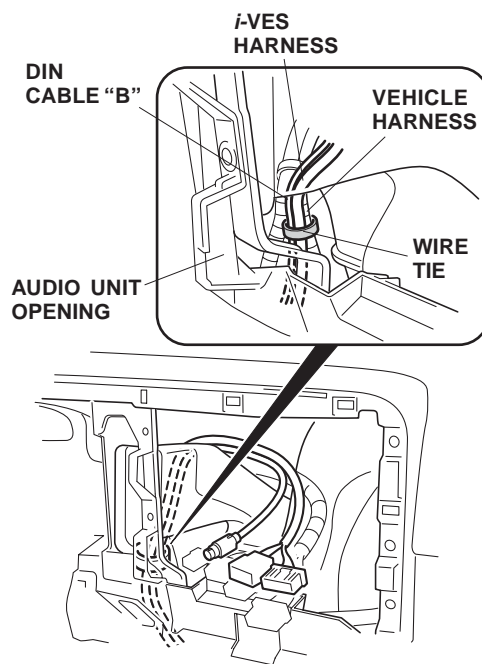

68. At the audio unit opening, plug the *i*-VES harness 20-pin connector into the vehicle 20-pin connector, and secure the 20-pin connectors with one long wire tie.

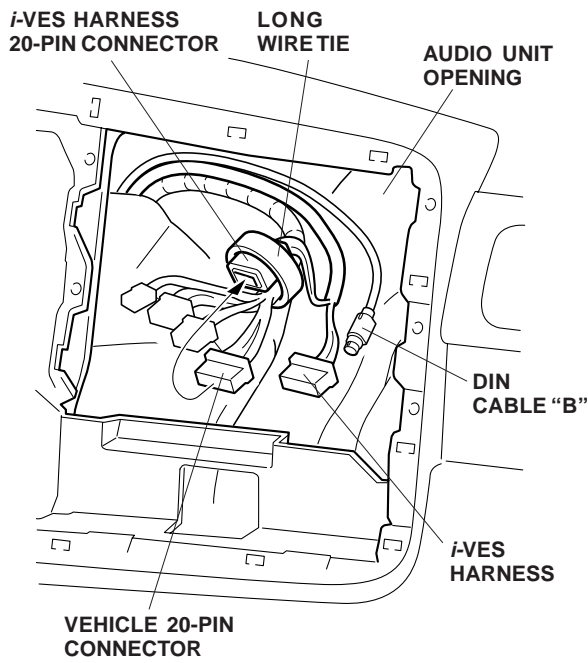

69. Secure the *i*-VES harness and DIN cable "B" to the vehicle harness with two wire ties in the areas shown.

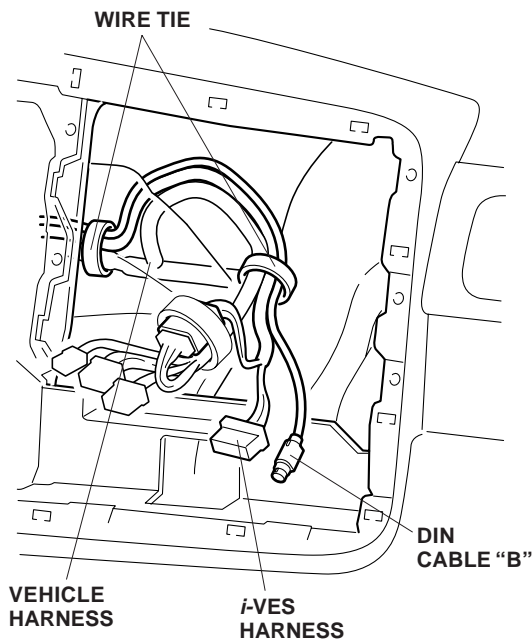

70. Secure DIN cable "A" to the vehicle harness with two wire ties in the areas shown.

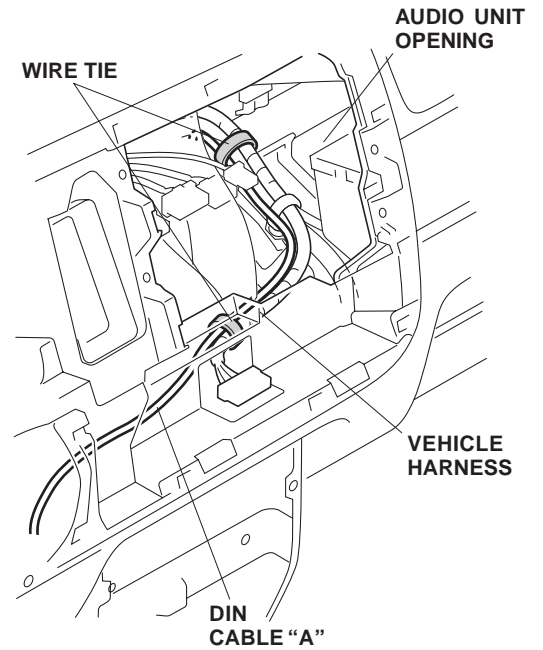

71. At the glove box opening, secure DIN cable "A" to the vehicle harness with three wire ties.

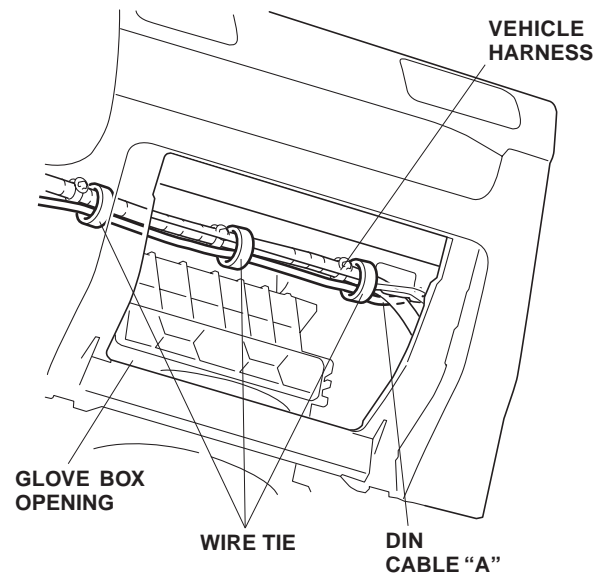

72. Using isopropyl alcohol on a shop towel, clean the area where the cushion tape will attach. Secure DIN cable "A" to the vehicle panel with one cushion tape.

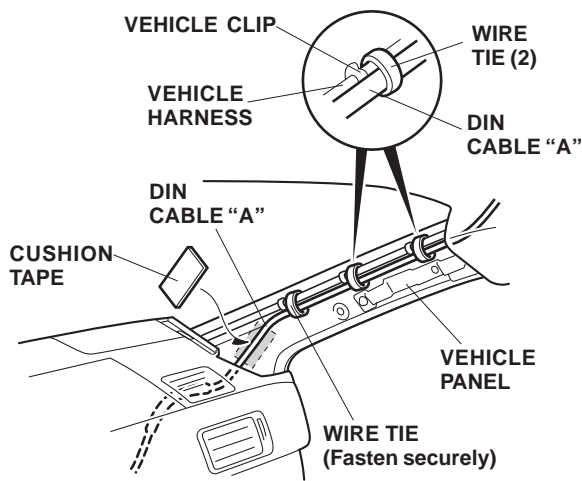

73. Secure DIN cable "A" to the vehicle harness with two wire ties, and tighten the wire tie you temporarily secured to DIN cable "A" in step 35.

74. Remove the rear interior light.

- Remove the two lenses (four tabs on each lens).
- Remove the two self-tapping screws.
- Unplug the vehicle 3-pin connector.

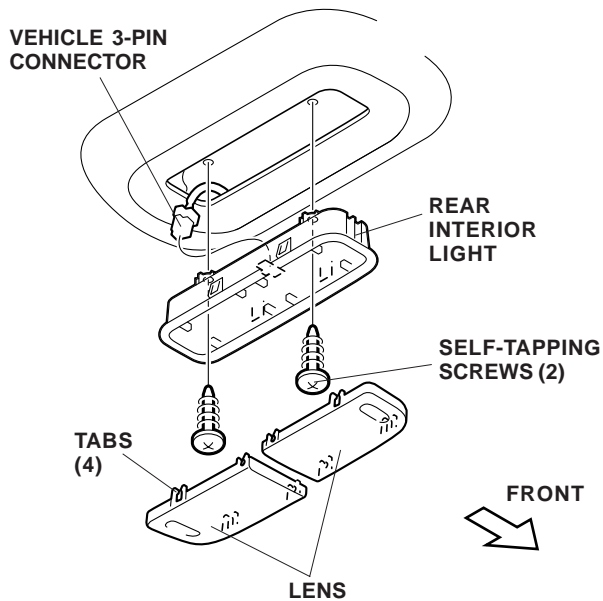

75. Route the interior light harness between the headliner and insulator from the interior light opening out the headliner opening.

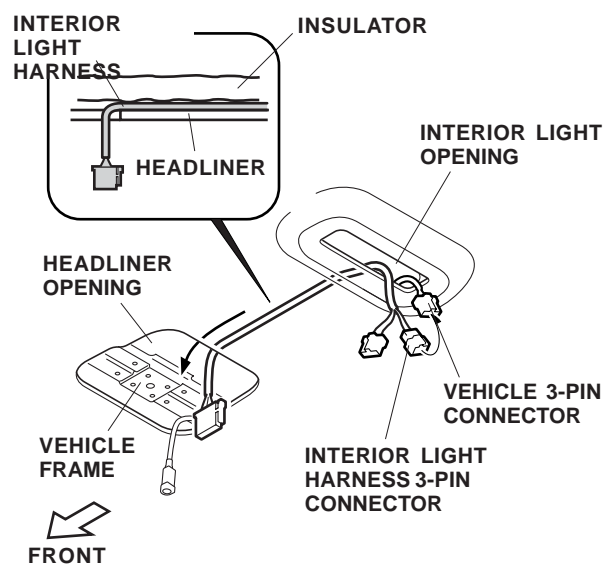

76. Plug the interior light harness 3-pin connector into the vehicle 3-pin connector.

77. Using isopropyl alcohol on a shop towel, clean the area where the cushion tape will attach. Using scissors, cut one cushion tape in half. Secure the interior light harness to the headliner with the cushion tape half.

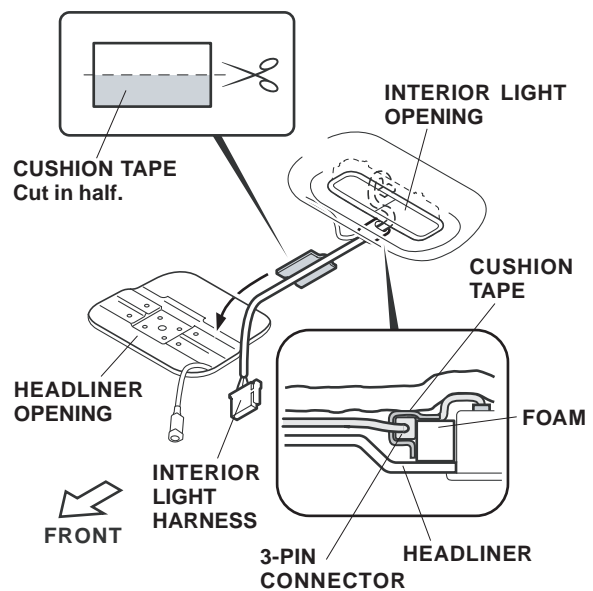

78. Position the 3-pin connector in the cavity in the headliner. Reinstall the rear interior light.

79. Using isopropyl alcohol on a shop towel, clean the areas where the cushion tapes will attach. Using scissors, cut three cushion tapes in half. Secure DIN cable "A" to the headliner with the six pieces of cushion tape.

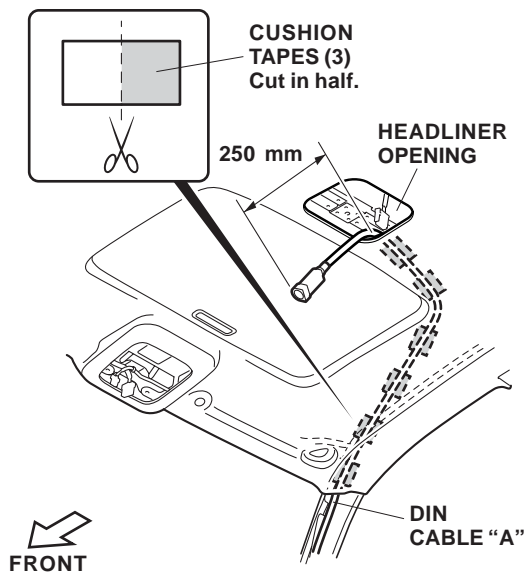

Installing the Monitor Console

80. Using isopropyl alcohol on a shop towel, clean the areas where the EPT sealers will attach. Using scissors, cut two EPT sealers in half. Attach the EPT sealer halves, and one EPT sealer to the monitor bracket in the areas shown. Cut the excess off the EPT sealers.

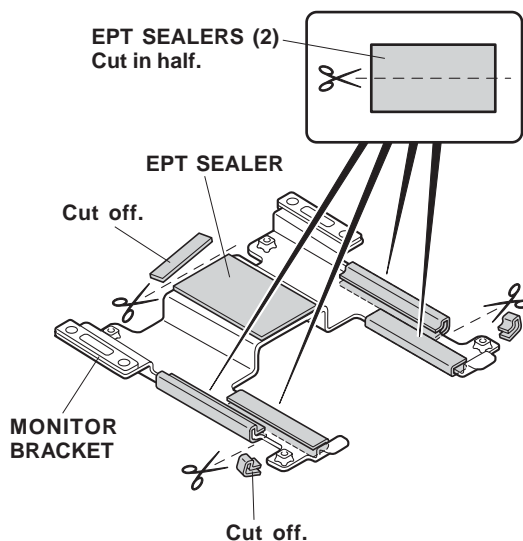

81. With the sunshade in the closed position, insert four square-head bolts through the holes in the vehicle frame.

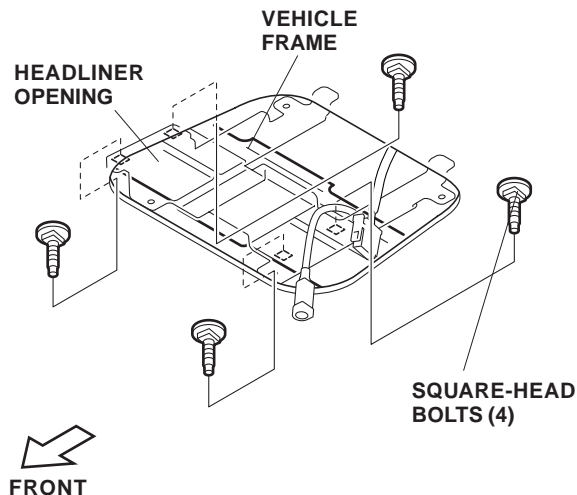

82. Secure the monitor bracket to the vehicle frame with four 4 mm flange nuts and the four square-head bolts you inserted.

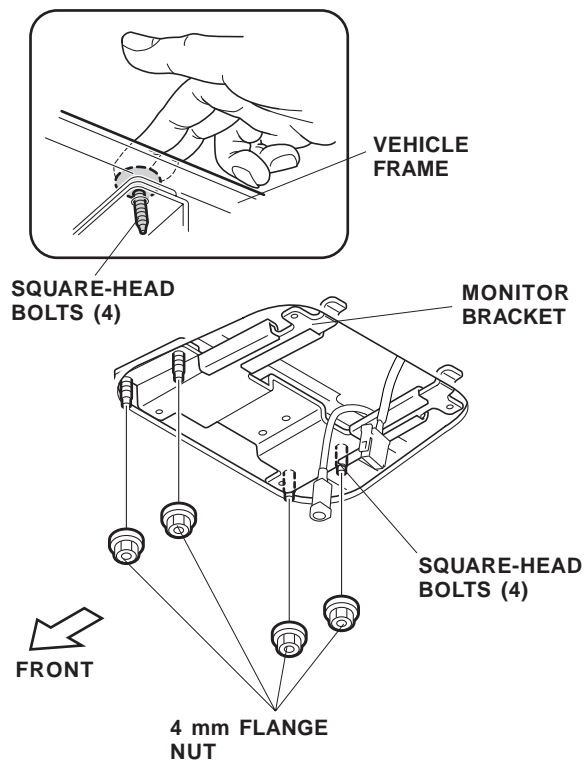

83. Remove the left and right lenses from the monitor console, then install the monitor gasket on the console while aligning the Δ mark of the monitor gasket with the Δ mark on the monitor console.

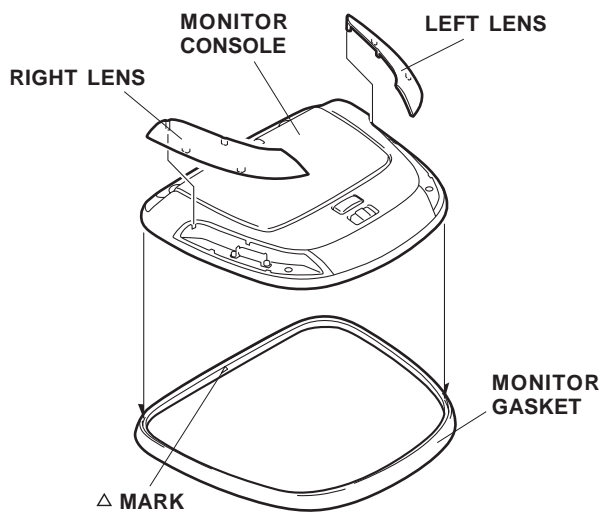

84. Remove the tape that secures the 3-pin connector to the monitor console. Connect the interior light harness 3-pin connector and DIN cable "A" terminal into the monitor console 3-pin connector and monitor console terminal.

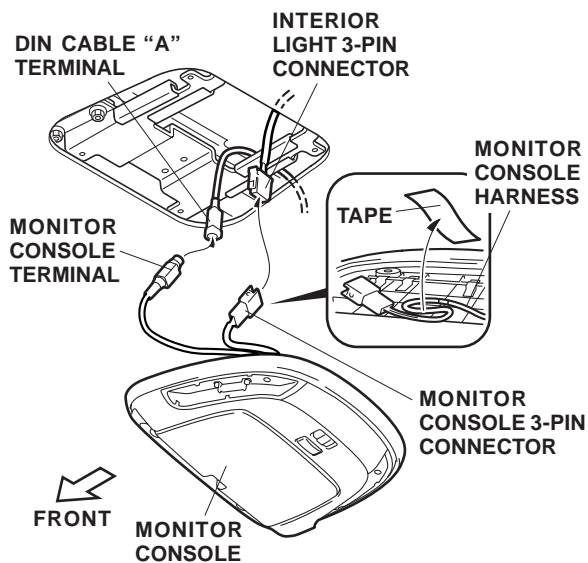

85. While holding the monitor console, secure the 3-pin connector and the terminal to the back of the monitor console with one cushion tape.

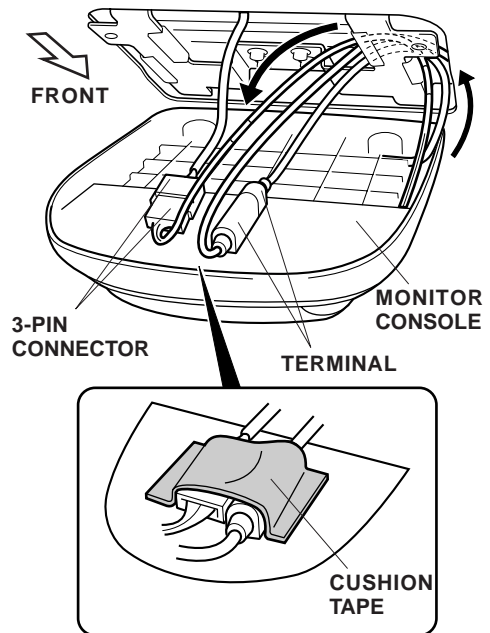

86. Position the monitor console on the monitor bracket, and install two 5 x 16 mm washer-screws and two 5 x 25 mm washer-screws. Install two screw caps, then reinstall the left and right lenses. Do not pinch the DIN cable "A" between the monitor console and monitor bracket.

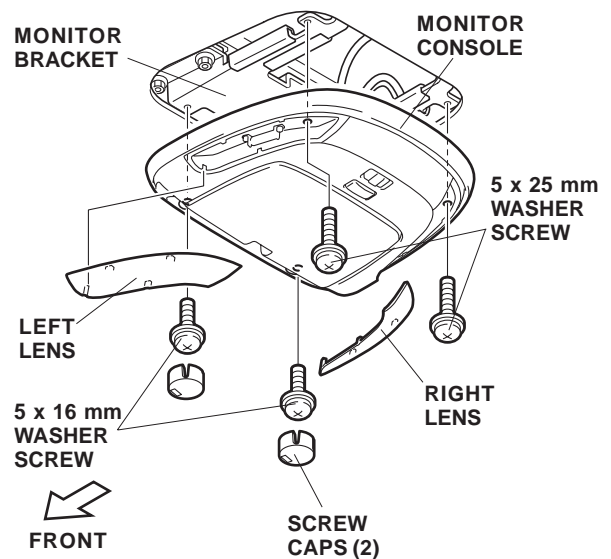

87. Secure the FM modulator bracket to the FM modulator with one 5 x 8 mm washer-screw included with the monitor kit.

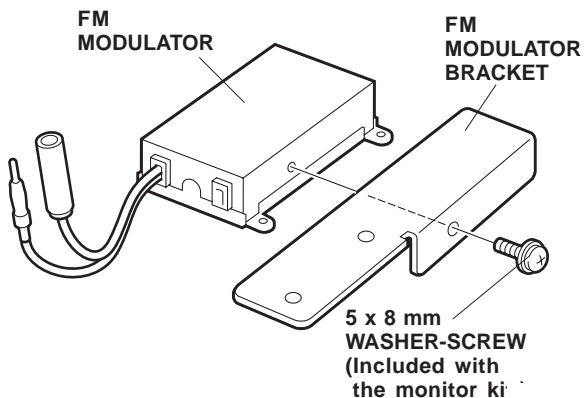

88. Set the FM modulator switch at 88.5. Using isopropyl alcohol on a shop towel, clean the area where the EPT sealer will attach. Using scissors, cut one EPT sealer in half. Secure the FM modulator cables to the FM modulator with one EPT sealer half.

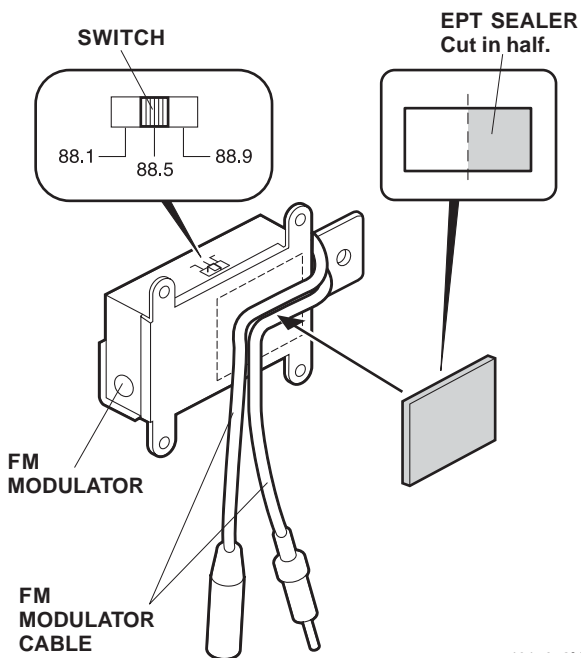

89. Using isopropyl alcohol on a shop towel, clean the area where the EPT sealer will attach. Attach one EPT sealer half that you cut into two in step 88 to the audio unit/navigation unit.

Without Navi

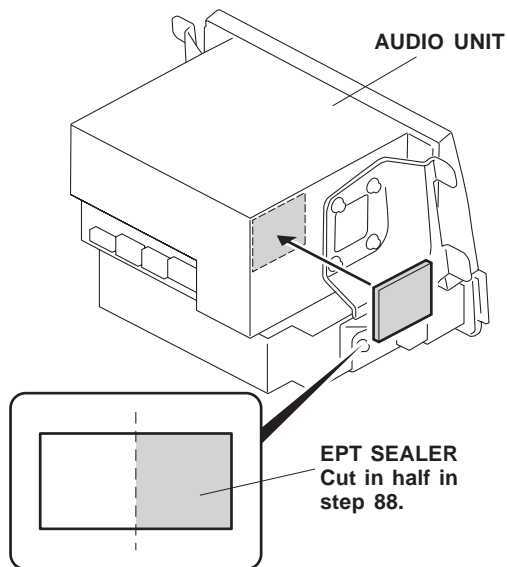

With Navi

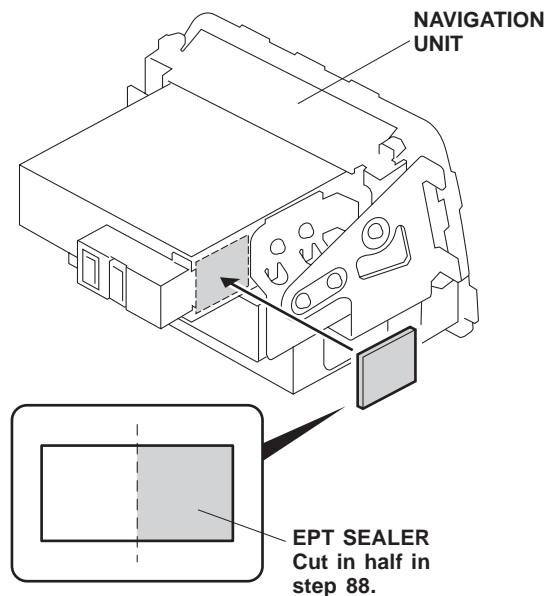

90. Remove two screws from the audio unit/navigation unit. Secure the FM modulator bracket to the audio unit/navigation unit with the two screws you removed.

Without Navi

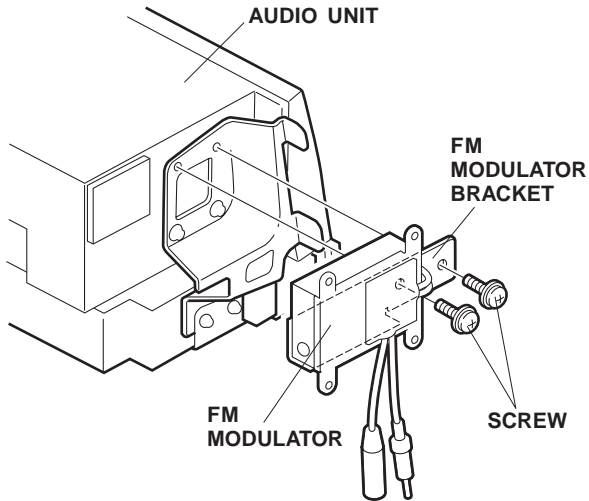

With Navi

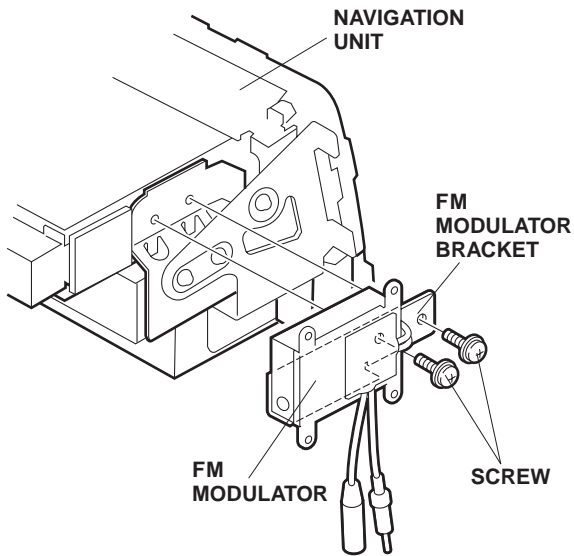

91. Plug the sub-feeder antenna leads into the FM modulator antenna leads. Plug the sub-feeder 2-pin connector into the audio unit/navigation unit.

Without Navi

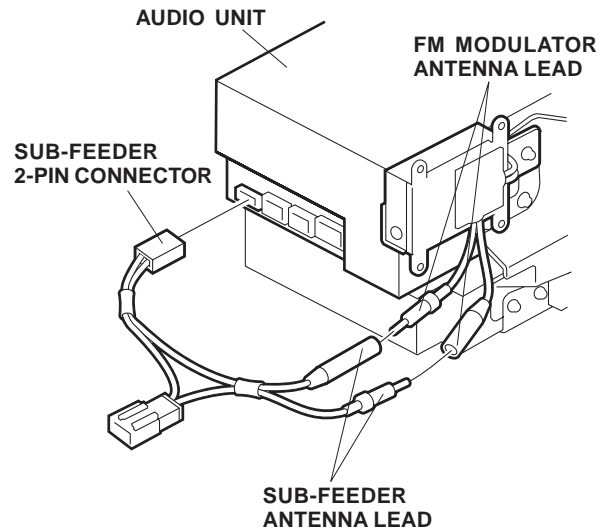

With Navi

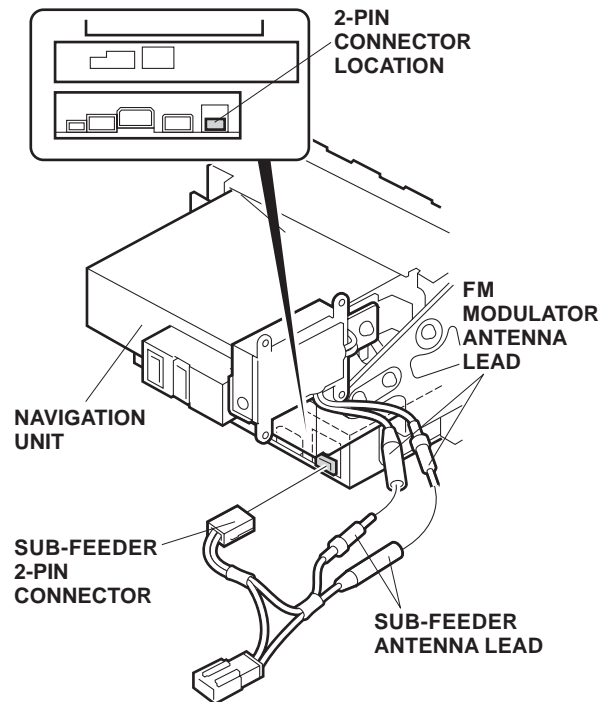

- Using scissors, cut two EPT sealers in half. Wrap the two half EPT sealer halves around the respective antenna leads as shown.

Without Navi

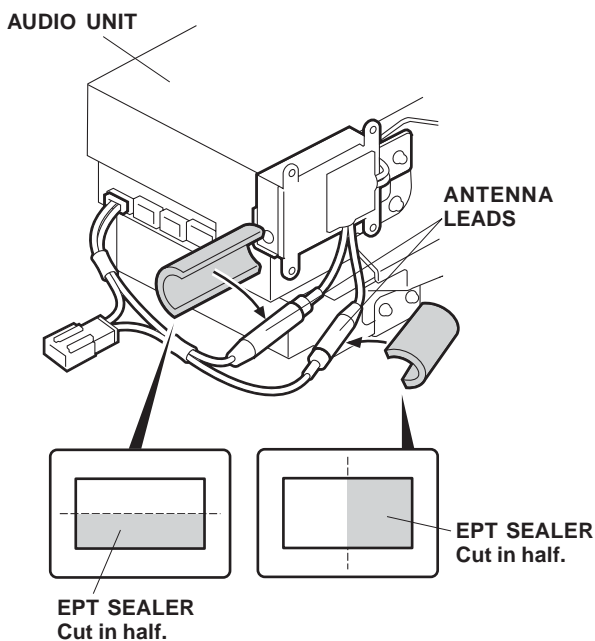

With Navi

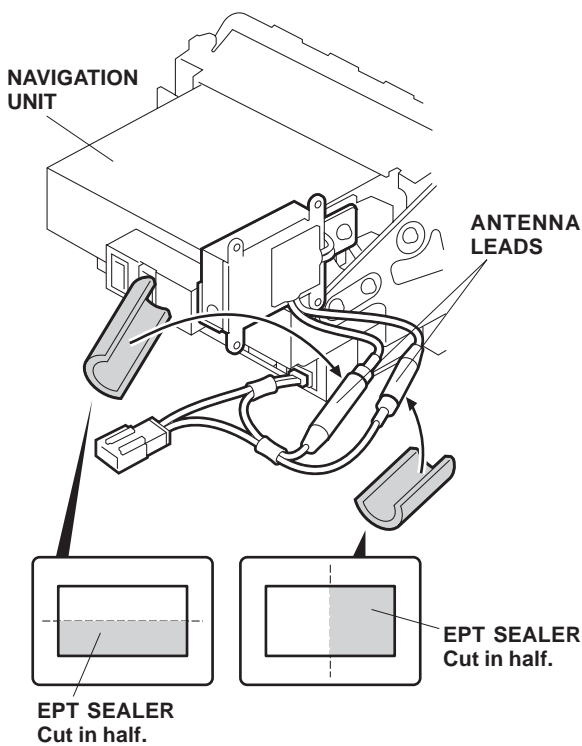

- Plug the vehicle antenna connector into the sub-feeder antenna 2-pin connector.

Without Navi

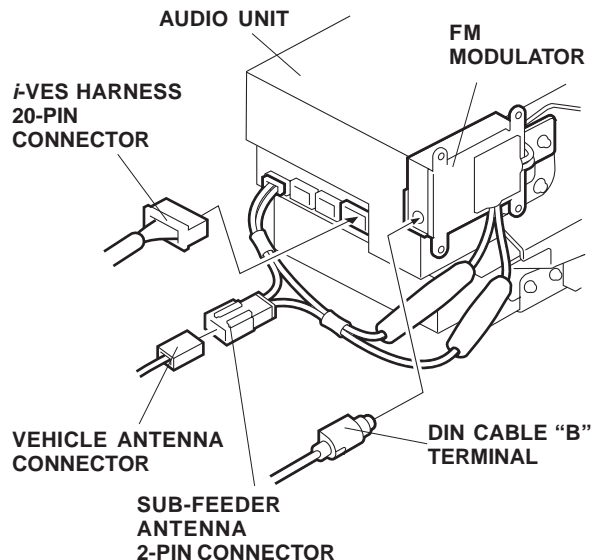

With Navi

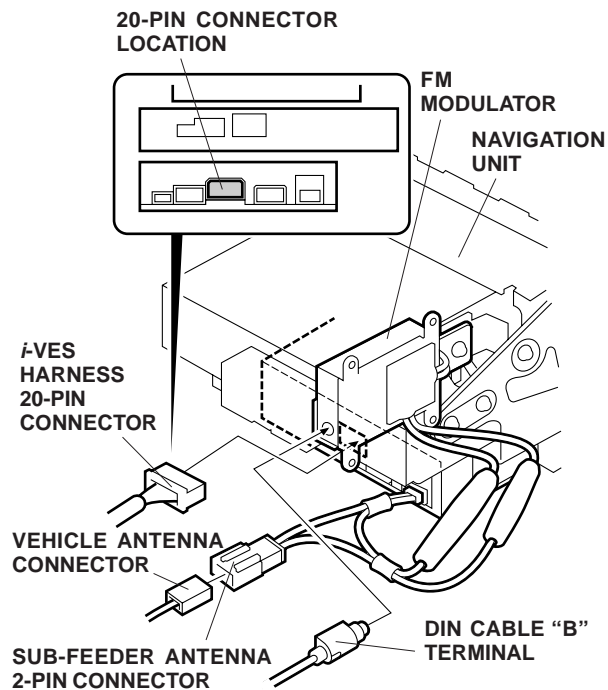

- Plug DIN cable "B" terminal into the FM modulator.
- Plug the *i*-VES harness 20-pin connector into the audio unit/navigation unit.
- Reinstall the audio unit/navigation unit.

97. Insert the Quick Reference Tag into the center console.

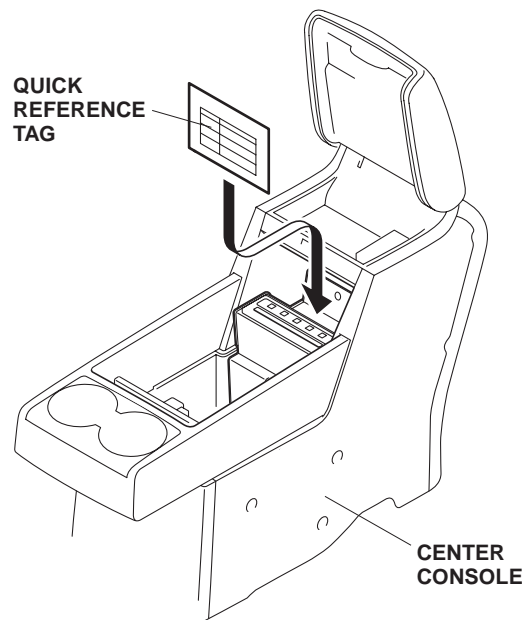

98. Check that all wire harnesses are routed properly and all connectors are plugged in.
99. Reconnect the negative cable to the battery.
100. Enter the customer's radio anti-theft code, and reset the radio station presets.
101. Reset the clock, and reset the radio station presets.
102. Check the operation of the in-Vehicle Entertainment System according to the Owner's Manual provided.
103. Put the in-Vehicle Entertainment System Owner's Manual in the glove box with the vehicle owner's manual.

104. Reinstall all removed parts. Torque the seat belt anchor bolts to 30 to 35 N·m (21 to 25 lbf·ft)

NOTE: Whenever the battery is disconnected, the driver's AUTO function is disabled.

105. Start the engine. Push down on the driver's window switch until the window is fully open.
106. Pull up on the driver's window switch fully to close the window completely, then hold the switch for 2 seconds or more.
107. Test the window AUTO function.