

## PARTS LIST

Wing spoiler

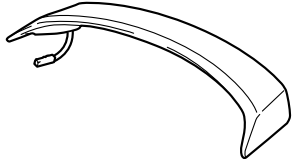

2 6 x 32 mm Washer screws  
(Not used)

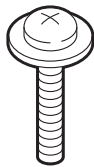

2 Cap nuts



4 Wire ties

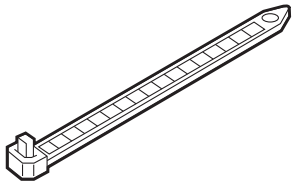

Left trunk spring



Right trunk spring



Main harness

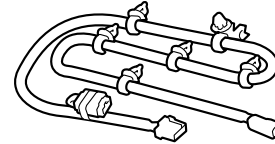

Template

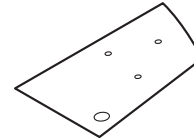

Cushion tape

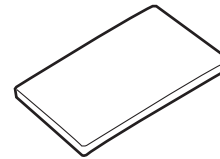

2 Grommets

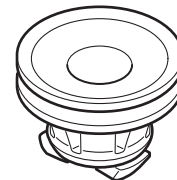

2 6 x 12 mm Washer screws



## TOOLS AND SUPPLIES REQUIRED

Phillips screwdriver  
Flat-tip screwdriver  
Ratchet  
Torque wrench  
10 mm Socket  
Center punch  
Drill  
3 mm, 6 mm, 8 mm, and 10 mm Drill bits  
16 mm Hole saw  
File  
Touch-up paint  
Heavy gloves  
Plastic Trim Tool (T/N: SILTRIMTL10)  
Eye protection (face shield, safety goggles, etc.)  
Masking tape  
Trunk Spring Tool (T/N 07AAF-SNAA100)  
Felt-tip pen  
Diagonal cutters

### *Illustration of the Components Trunk Spoiler Installed on the Vehicle*

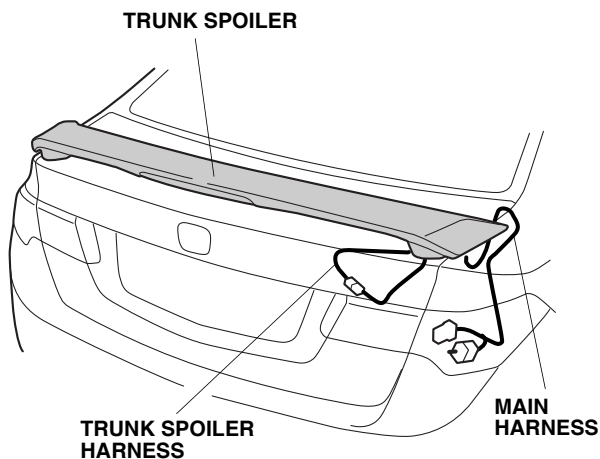

## INSTALLATION

**Client Information:** The information in this installation instruction is intended for use only by skilled technicians who have the proper tools, equipment, and training to correctly and safely add equipment to your vehicle. These procedures should not be attempted by “do-it-yourselfers.”

### NOTE:

- Wash and wax the area to be covered with a high-quality paste wax.
- The trunk springs are different for the left and the right side. (The spring for the left side is marked with red paint. The spring on the right is marked with yellow paint.) Please identify the left and right springs side before installation.

### Installing the Trunk Spoiler

1. Make sure you have the anti-theft codes for the audio system and navigation system (if equipped). Then write down the radio presets.
2. Disconnect the negative cable from the battery.
3. Open the trunk lid and remove the trunk floor mat (two clips).

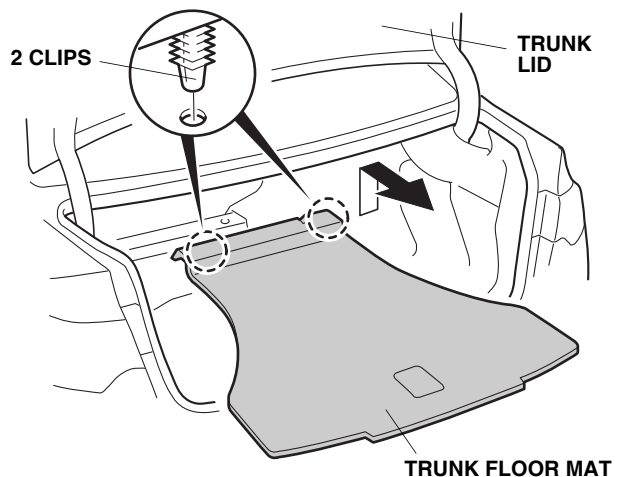

- Pull away the weatherstrip and remove the rear trim panel (five clips and two hooks).

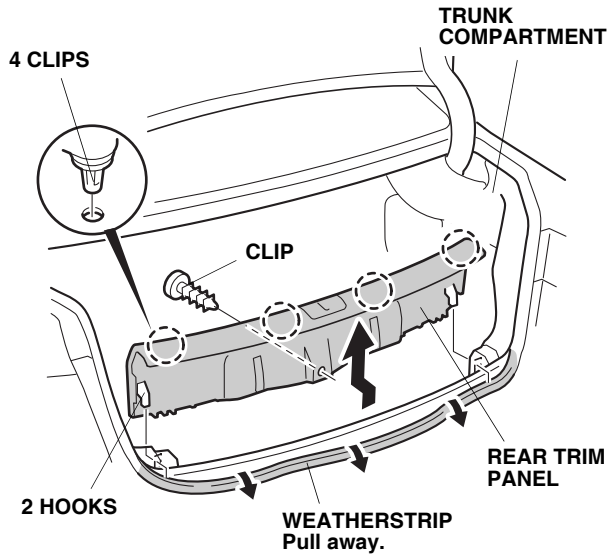

- Pull the left and right rear seatback lock openers to tilt the left and right rear seatbacks forward.

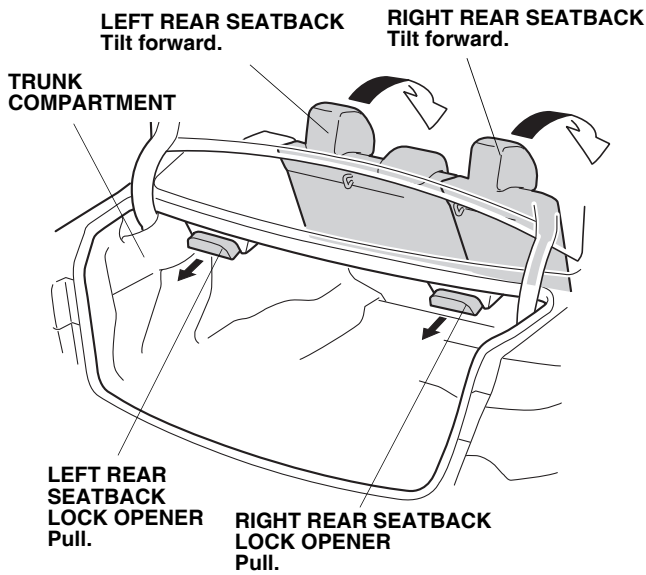

- Pull away the weatherstrip and remove the right trunk side trim panel (five clips and two vehicle hooks).

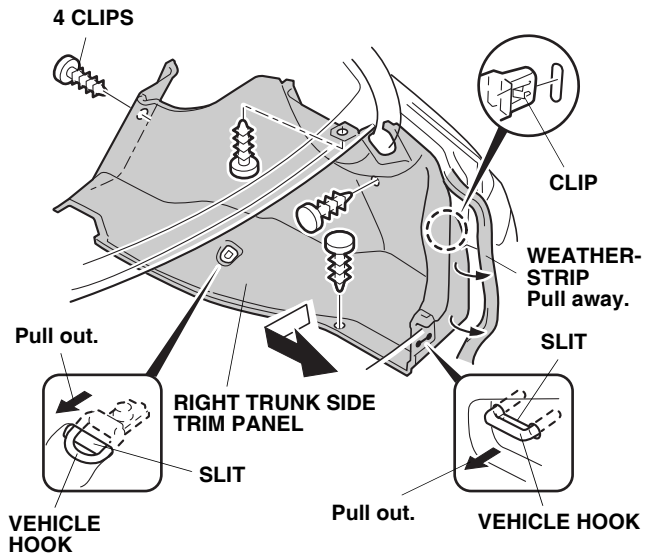

- Remove the right trunk hinge arm covers from the right trunk hinge arm (three clips and four retaining tabs). Remove the left trunk lid hinge arm cover the same way.

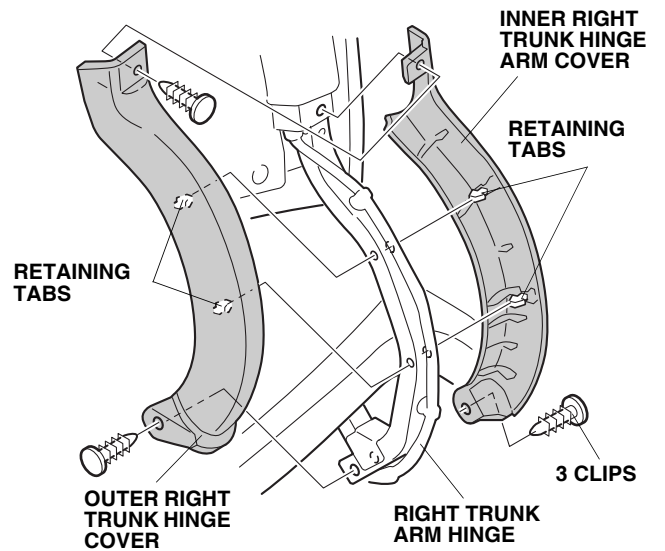

8. Remove the trunk trim panel (eight clips).

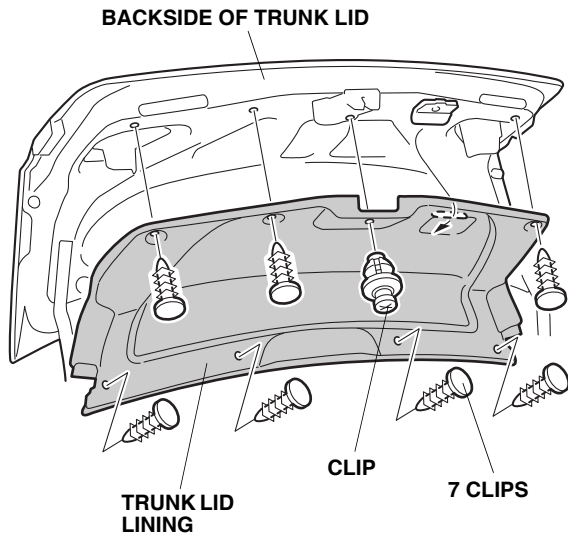

9. Using a felt-tip pen mark the rubber stopper at its current location, then remove the rubber stopper. Mark and remove the other rubber stopper the same way.

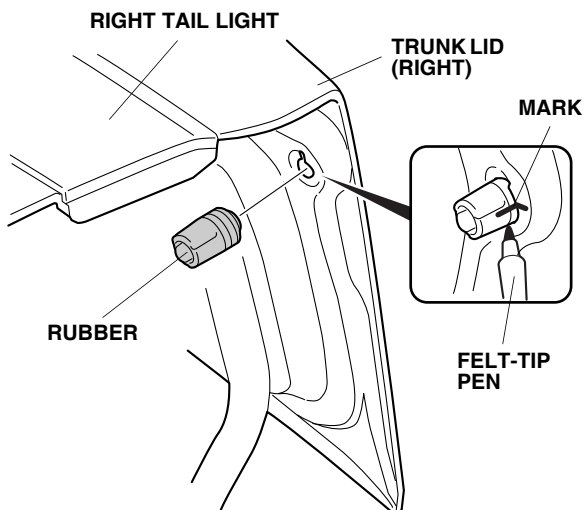

10. On the inside of the trunk lid, locate the two identification marks on the trunk lid. Lightly center-punched each mark. Repeat on the left side of the trunk lid.

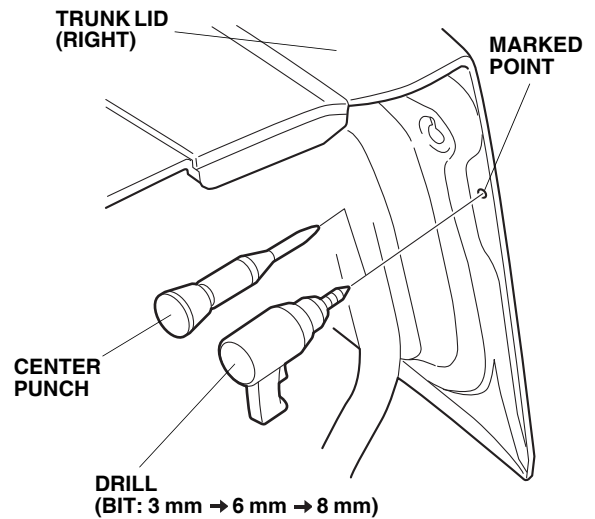

11. While wearing eye protection, first drill with a 3 mm drill bit, then with a 6 mm drill bit, and finish with an 8 mm drill bit.
- To prevent metal shavings from falling onto the trunk floor, place a cover over the trunk floor.
  - Remove all burrs and metal shavings, and apply touch-up paint to the edges of the holes you drilled.
  - Repeat on the right side of the trunk lid.
  - Close the trunk lid.

12. Mark the rear edge of the trunk lid:

- Attach masking tape to the left and right edges of the trunk lid in the areas shown.
- Place the template on the left trunk lid, and align the 8 mm hole in the template with the 8 mm trunk hole.
- Using an 8 mm drill bit as a guide, align the edge of the template with the edge of the trunk lid. Tape the inboard edge of the template to the trunk lid.
- On the **left side** of the trunk lid, center punch the trunk lid in **two** places.
- On the **right side** of the trunk lid, center punch the trunk lid in **three** places.
- Remove the template.

Left Side:

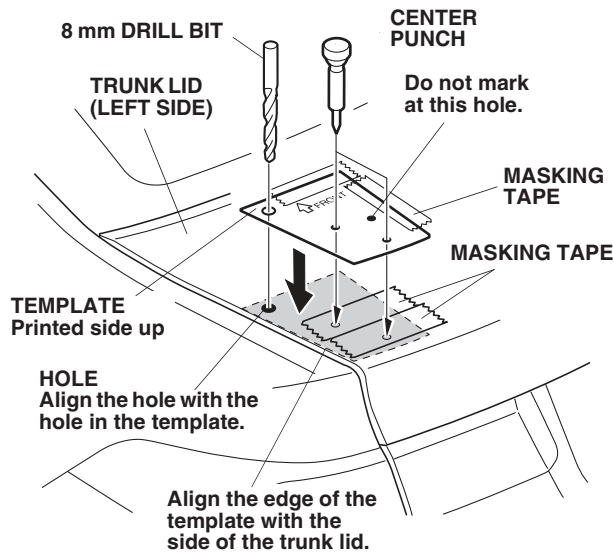

Right Side:

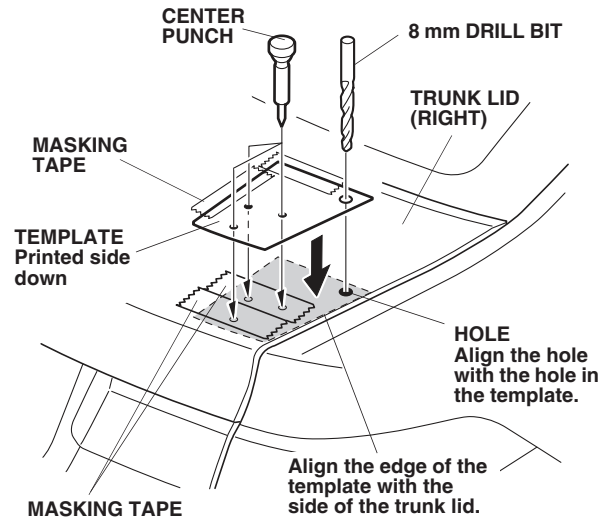

13. While wearing eye protection, drill the **right side** of the trunk lid:

- Wrap tape around each drill bit 10 mm from the tip or use a drill stop.
- To prevent metal shavings from falling into the trunk area, cover the trunk floor with a drop cloth.
- Drill only the two forward marks at this time using a 3 mm drill bit, then a 6 mm drill bit.
- Enlarge the inboard hole to 10 mm using a 10 mm drill bit.
- Remove all burrs and metal shavings, and apply touch-up paint to the edges of the holes.

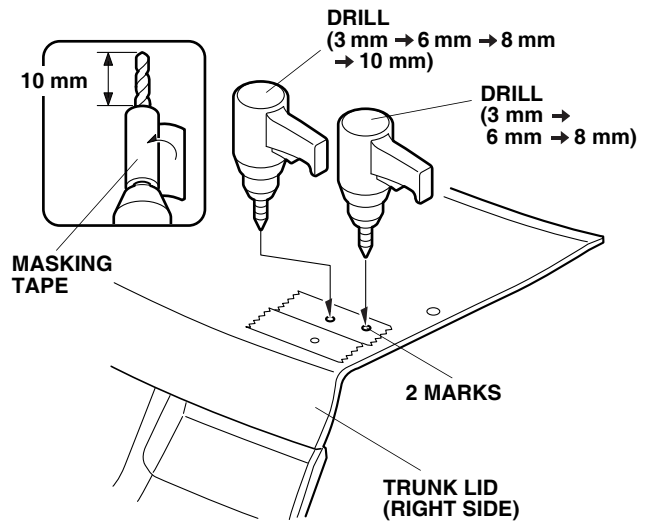

14. While wearing eye protection, drill the **left side** of the trunk lid.
- Wrap the tape around each drill bit 10 mm from the tip or use a drill stop.
  - To prevent metal shavings from falling into the trunk area, cover the floor with a drop cloth.
  - Drill only the one forward mark at this time using a 3 mm drill bit, then a 6 mm drill bit, and finish with a 8 mm drill bit.
  - Remove all burrs and metal shavings, and apply touch-up paint to the edges of the hole.

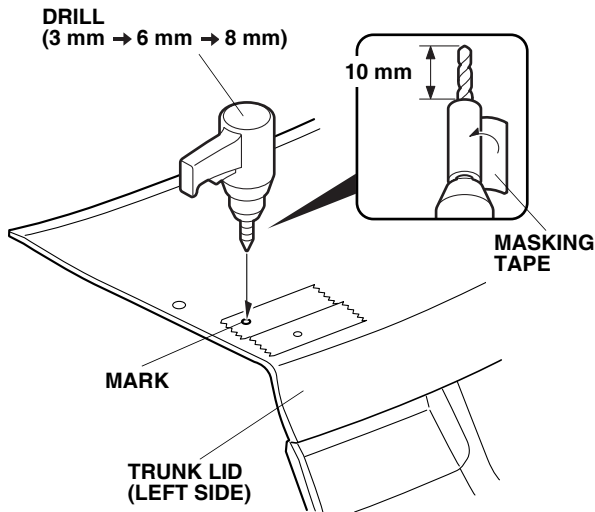

15. Drill the two remaining center-punched marks in the trunk lid:
- To prevent metal shavings from falling into the trunk area, cover the trunk floor with a drop cloth.
  - While wearing eye protection, drill the **left and right side** of the trunk lid using a 16 mm hole saw.
  - Remove all metal shavings and apply touch-up paint to the edges of the holes. Allow the touch-up paint to dry before proceeding to the next step.

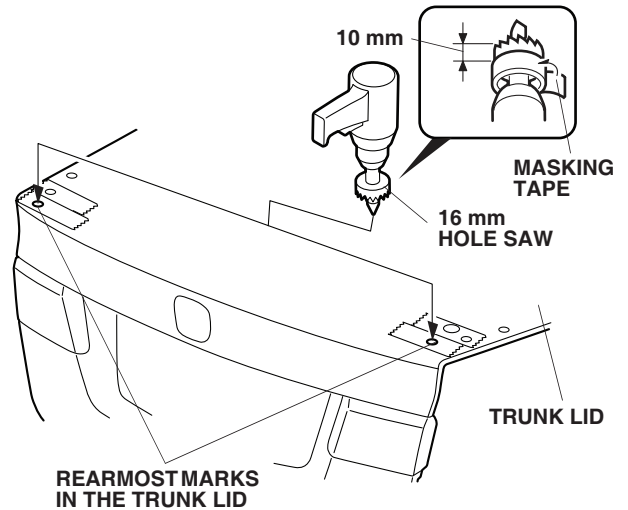

16. Install one grommet into each 16 mm hole in the trunk lid.

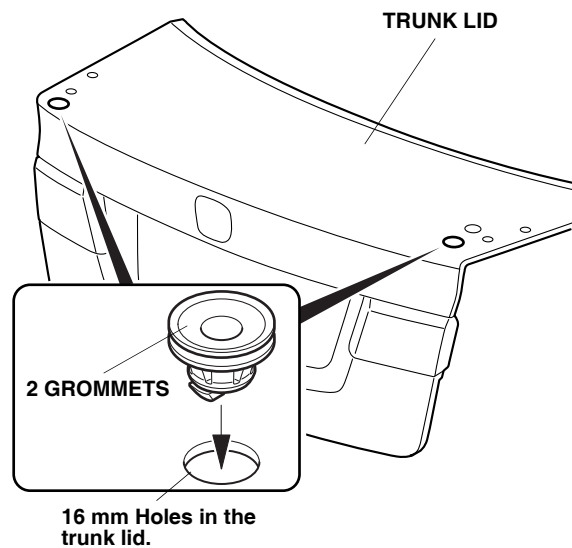

- Open the trunk lid and position the trunk spoiler on the trunk lid as shown. Seat the trunk spoiler harness grommet into the hole as shown, and loosely install the trunk spoiler using the two cap nuts.

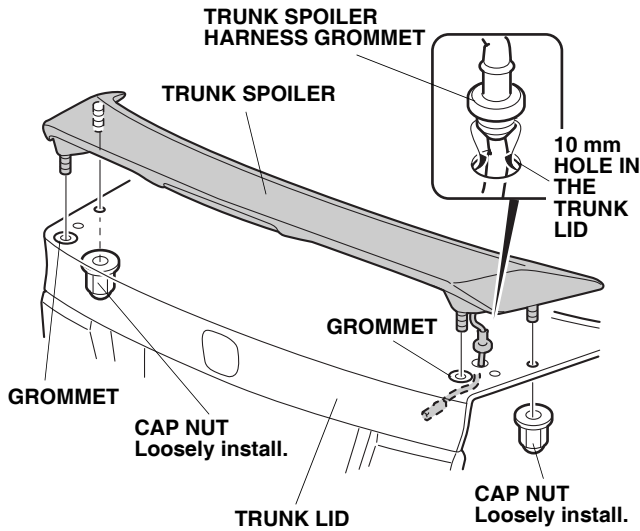

- On each side install one 6 x 12 mm washer screw into the trunk spoiler.

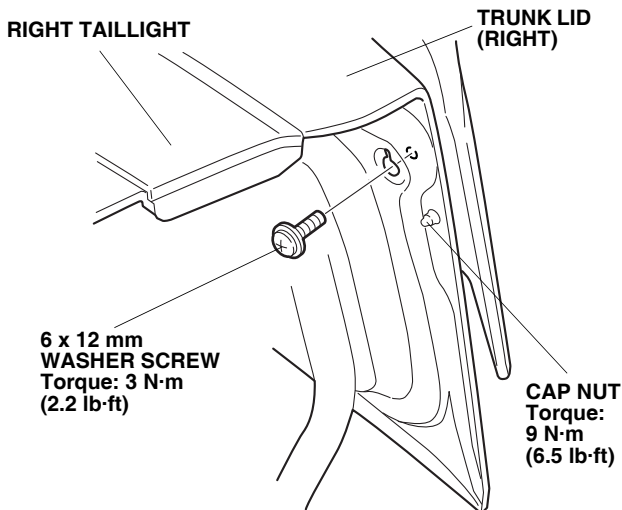

- Torque the washer-screw to 3 N·m (2.2 lb-ft) then torque the cap nuts to 9 N·m (6.5 lb-ft). Reinstall the rubber stoppers you removed in step 9.

- Route the trunk spoiler harness through the lid as shown.

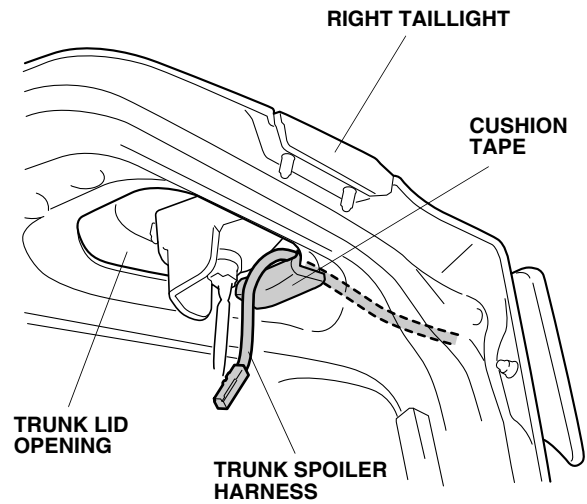

- Using isopropyl alcohol on a shop towel, clean the area where the cushion tape will attach. Attach one cushion tape around the trunk frame in the area shown.
- Get the main harness. Plug the main harness 2-pin connector into the trunk spoiler harness 2-pin connector.

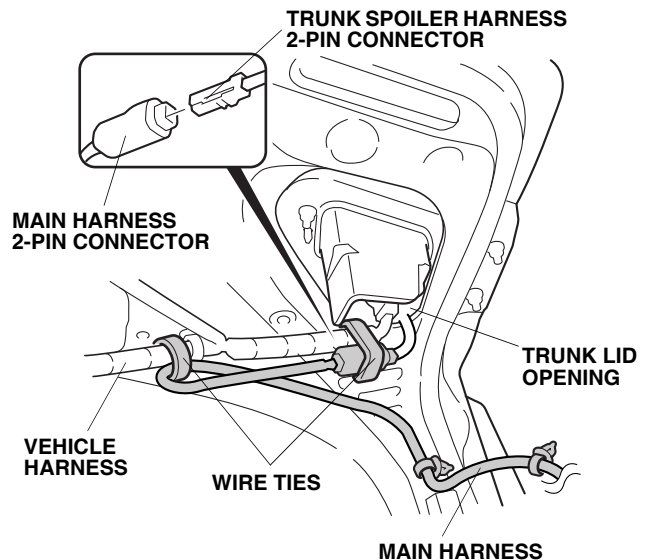

- Secure the main harness to the vehicle harness using two wire ties.

24. Remove the trunk opener cable from the right trunk hinge arm (four clips). Remove the four clips from the cable.

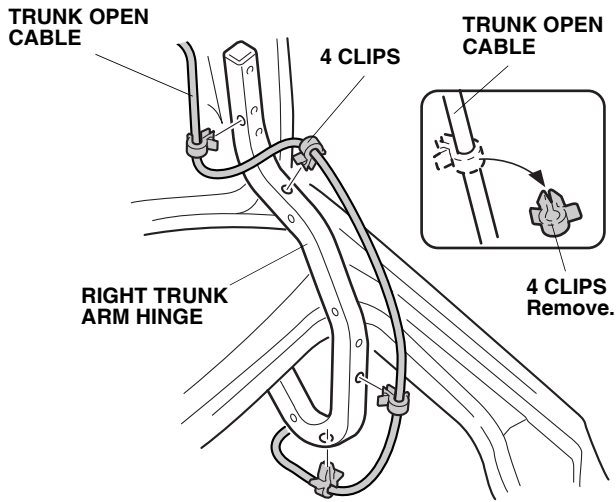

25. Secure the five main harness clips to the holes.

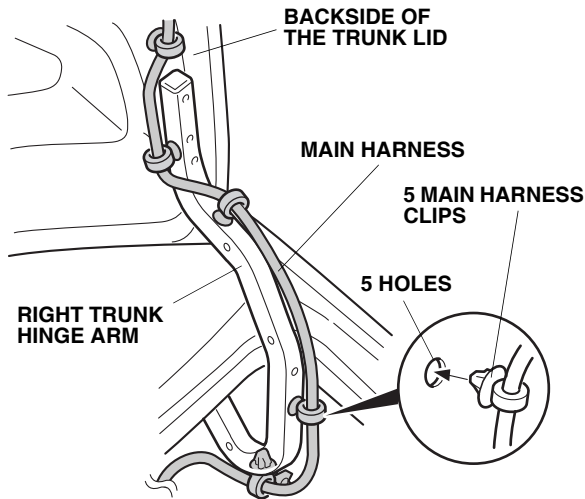

26. Reinstall the trunk lid trim panel removed in step 8.

27. Locate the mark on the trunk opener cable, and attach the opener cable to the lower main harness clip at the mark.

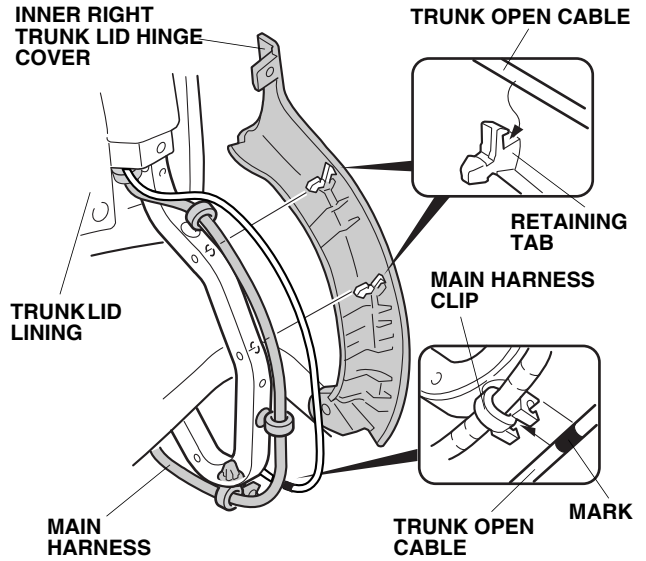

28. Install the trunk opener cable to the two retaining tabs on the inner right trunk hinge arm cover.  
29. Reinstall the outer right trunk hinge arm cover.

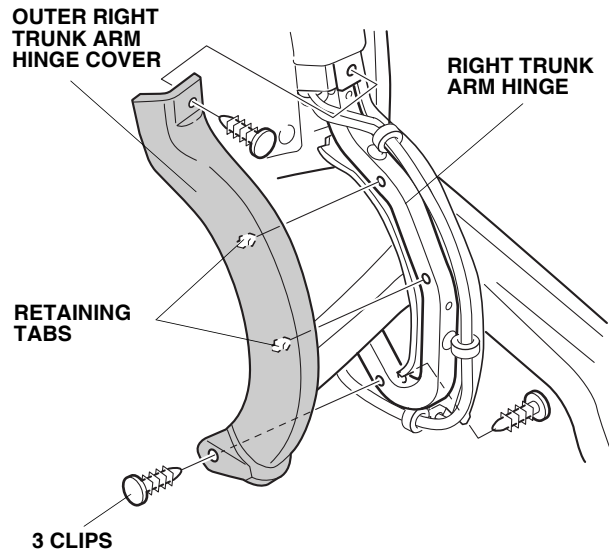

- Secure the remaining main harness clip to the hole in the vehicle panel.

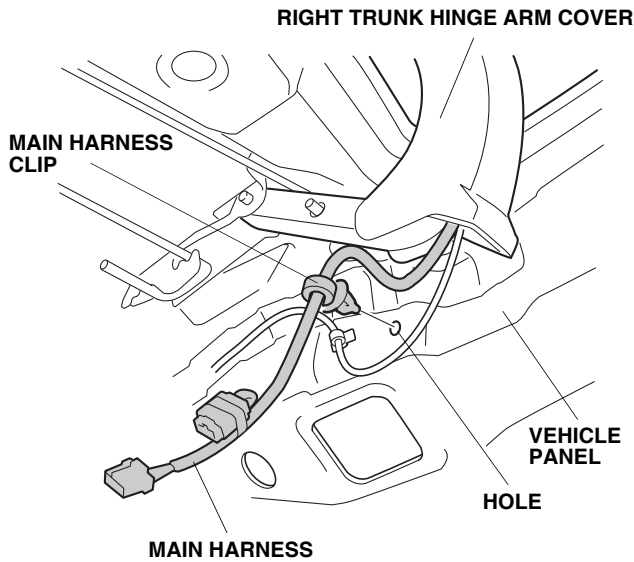

- Unplug the vehicle 4-pin connector from the right taillight, and plug the main harness 4-pin into the taillight. Plug the taillight 4-pin connector into the main harness 4-pin connector.

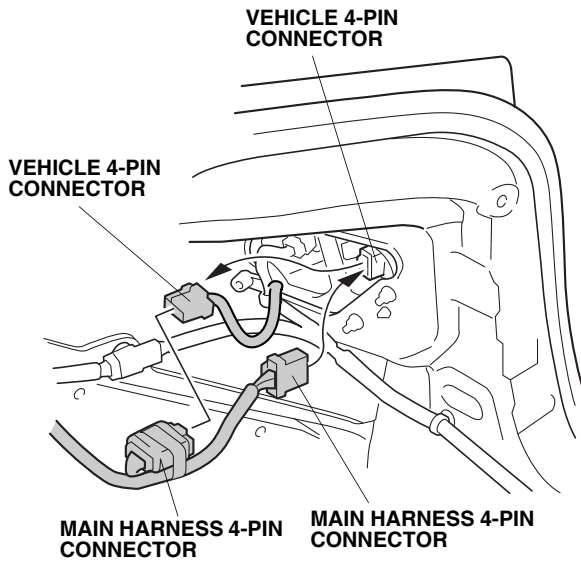

- Secure the main harness to the vehicle harness using two wire ties. If the vehicle you are working on does not have a harness, secure the main harness to the hole in the vehicle as shown.

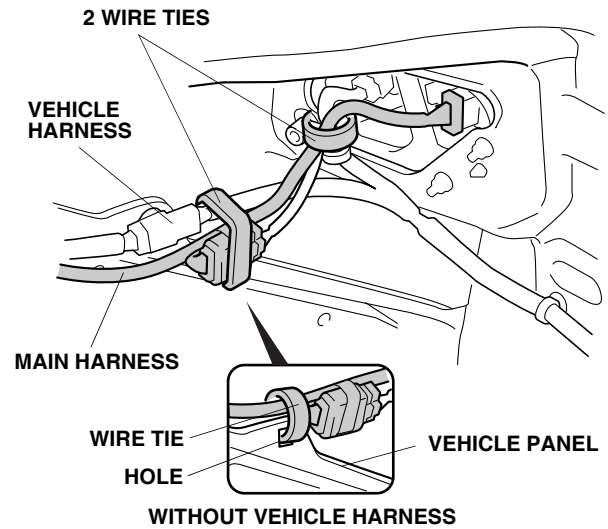

- Unplug the vehicle 2-pin connector from the high-mount brake light.

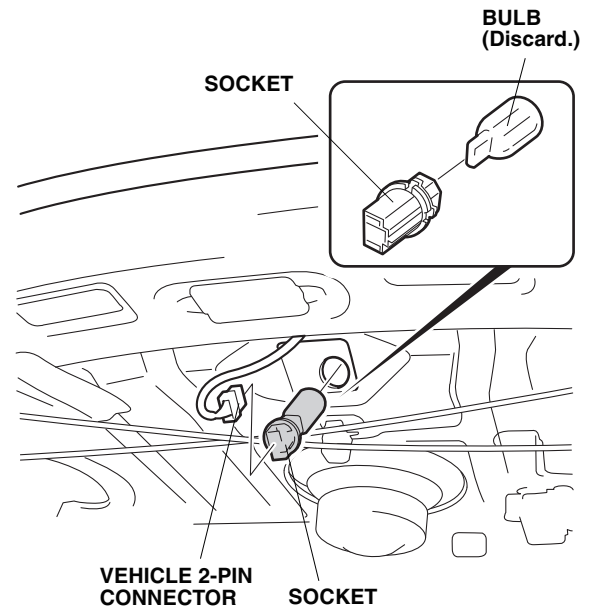

- Remove the socket from the high-mount brake light by turning it counterclockwise, then remove the bulb from the socket.
- Reinstall the socket to the high-mount brake light, and plug the vehicle 2-pin connector to the high-mount brake light.

## Installing the Trunk Springs

36. Open the trunk lid, and remove the center clip from the trunk springs.)

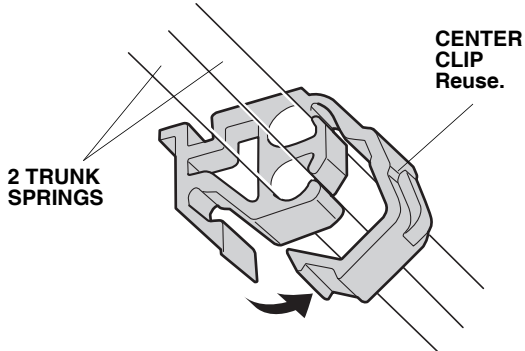

37. With an assistant holding the trunk lid open, remove the old trunk springs from the trunk hinge arms using the trunk spring tool. Wear gloves to protect your hands, and pull the trunk spring tool slowly and carefully towards you.)

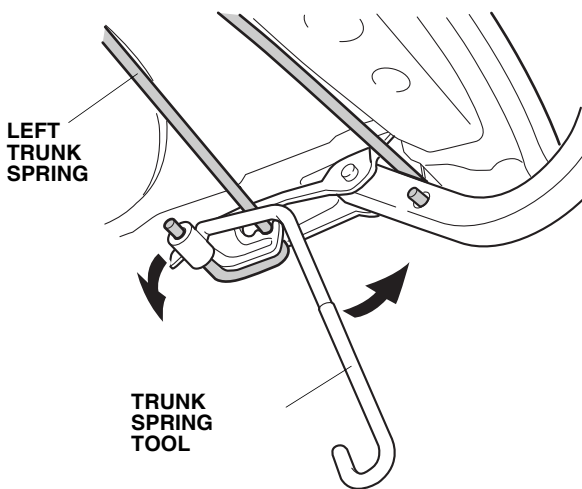

38. Install the right trunk spring and the left trunk spring in the reverse order of removal:
- Set the tool on the marked end of each trunk spring.
  - Install the yellow marked spring in the slot in the right (passenger's) side trunk hinge arm and in the hinge bracket on the left (driver's) side of the vehicle; install the red marked spring in the slot in the left (driver's) side trunk hinge arm and in the hinge bracket on the right (passenger's) side of the vehicle.
  - Wearing gloves, rotate the tool as you pull it towards you.
  - Set the springs in the first notch (original position) of the hinge brackets.
  - Reinstall the center clip.

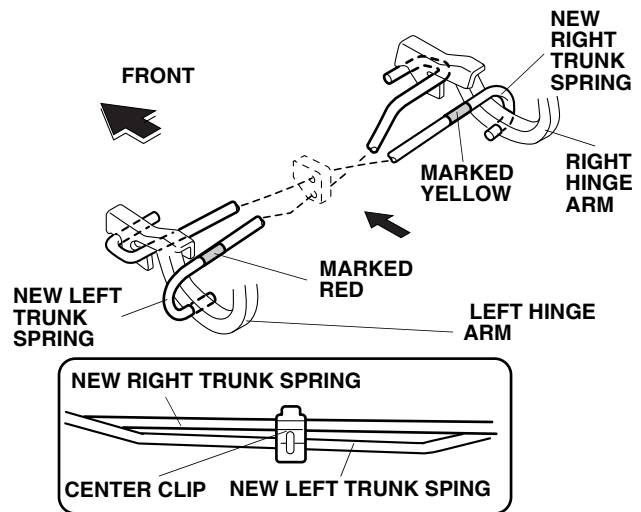

39. Check that all wire harnesses are routed properly and all connectors are plugged in.
40. Press on the brake pedal, and check that the spoiler brake light comes on.
41. Reinstall all removed parts.
42. Reconnect the negative cable to the battery.
43. Reset the clock, and reset the radio station presets.