

<http://www.HandA-Accessories.com>

PARTS LIST

Left side step

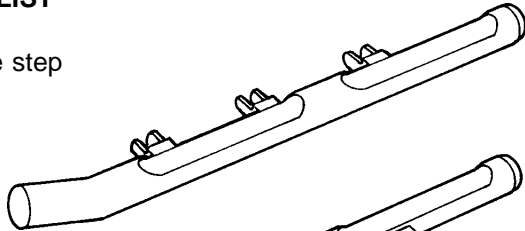

Right side step

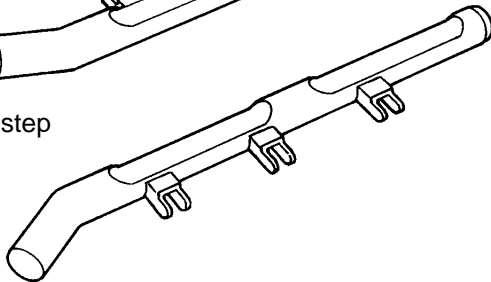

6 "A" brackets

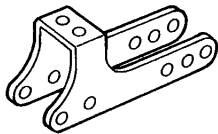

6 "B" brackets

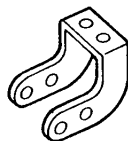

24 Long flange bolts



48 Short flange bolts



48 Flange nuts



TOOLS AND SUPPLIES REQUIRED

- Ratchet
- 13 mm Socket
- 10 mm Combination wrench
- Cardboard or blanket
- Torque wrench
- Flat-tip screwdriver

INSTALLATION

NOTE:

- Thoroughly clean the bottom of the body from the rear of the front wheels up to the front of the rear wheels.
- Be careful not to damage the body paint finish. To prevent damage, place a cardboard or blanket under the side step during the installation.
- These instructions show the left side step being installed; the same procedure applies to installing the right side step.

1. For the two front bracket assemblies, use brackets "A" and "B," four short flange bolts and four flange nuts. Leave the nuts and bolts loose at this time.

Front Bracket Assembly:

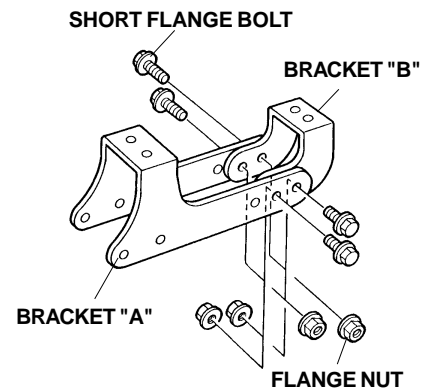

2. To assemble four center and rear bracket assemblies, use brackets "A" and "B," four short flange bolts and four flange nuts. Leave the nuts and bolts loose at this time.

Center and Rear Bracket Assembly:

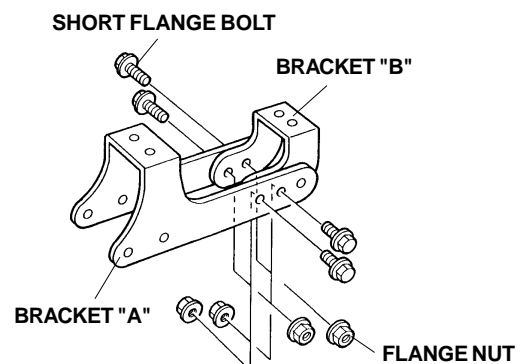

- Remove the six clips from the bottom of the body.

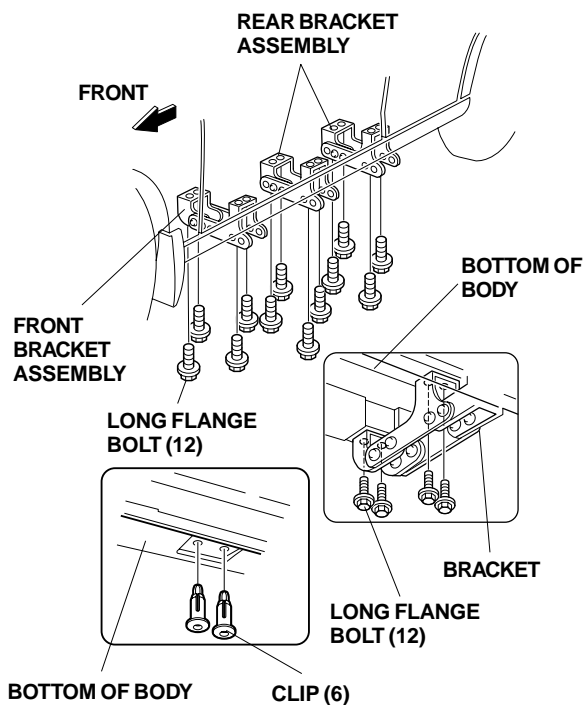

- On the left side of the vehicle, install one bracket assembly at the front, one at the center, and one at the rear along the body using 12 long flange bolts. Thread the long flange bolts in about 3 or 4 threads.
- Install the left side step to the bracket assemblies using 12 short flange bolts and 12 flange nuts. Torque the flange bolts to 23 N•m (17 lb-ft).

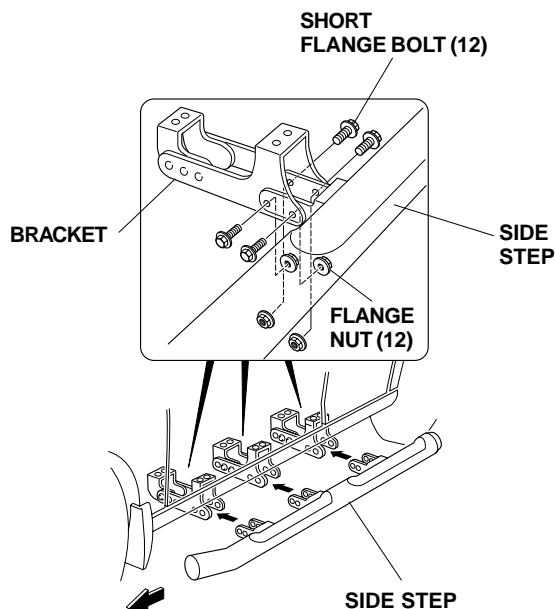

- Adjust the location of the left side step so that even clearance is obtained between the side step and body, then tighten the long flange bolts you installed in step 4. Torque the long flange bolts to 23 N•m (17 lb-ft).

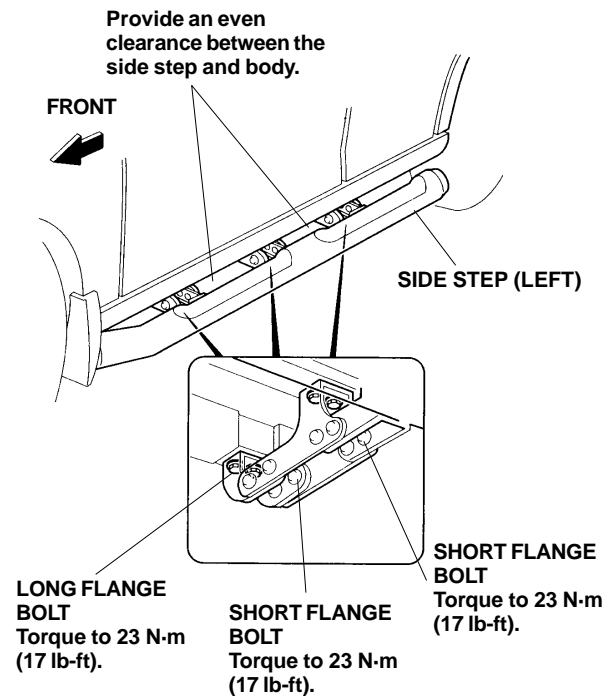

- Torque the short flange bolts you installed in steps 1 and 2 to 23 N•m (17 lb-ft).
- Repeat steps 1 through 7 to install the side step on the right side of the vehicle.