

<h1>INSTALLATION INSTRUCTIONS</h1>	Accessory BUMPER TRIM P/N 08P01-S3V-260	Application MDX	Publications No. BII 23279
			Issue Date NOV 2001

<http://www.HandA-Accessories.com>

PARTS LIST

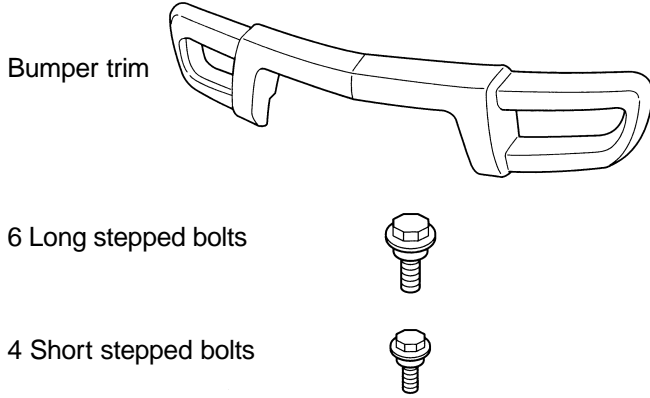

TOOLS AND SUPPLIES REQUIRED

- Phillips screwdriver
- Flat-tip screwdriver
- 10 mm Socket
- Ratchet
- Drill
- 3 mm and 10 mm Drill bits
- File
- Blanket

INSTALLATION

Customer Information: The information in this installation instruction is intended for use only by skilled technicians who have the proper tools, equipment, and training to correctly and safely add equipment to your vehicle. These procedures should not be attempted by "do-it-yourselfers."

NOTE: Be careful not to damage the front bumper and other finished surfaces of the body. To prevent damage to the front bumper and front lower skirt, place the front bumper on a blanket during the installation.

1. Open the hood, and remove the five clips that secure the top of the front bumper.

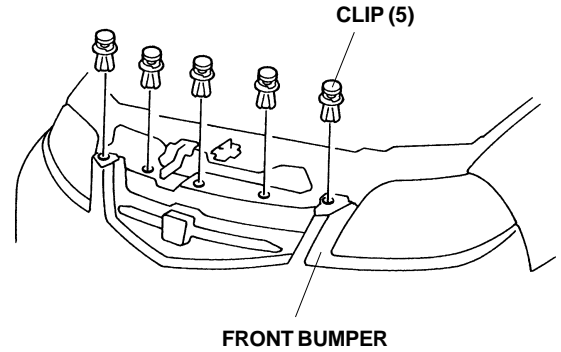

2. Remove the two self-tapping screws, two clips and four bolts that secure the front bumper.

If the vehicle is equipped with optional fender flares, remove the top inner fender screws securing the bumper.

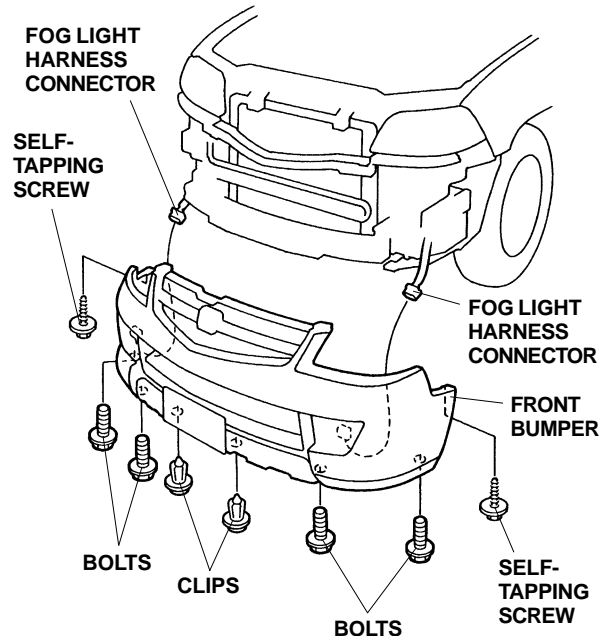

3. Pull the front bumper out toward you, then disconnect the fog light harness connectors. Remove the front bumper and place it on a blanket.

- On the inside of the front bumper, locate the 10 scribed marks. Center-punch each mark.

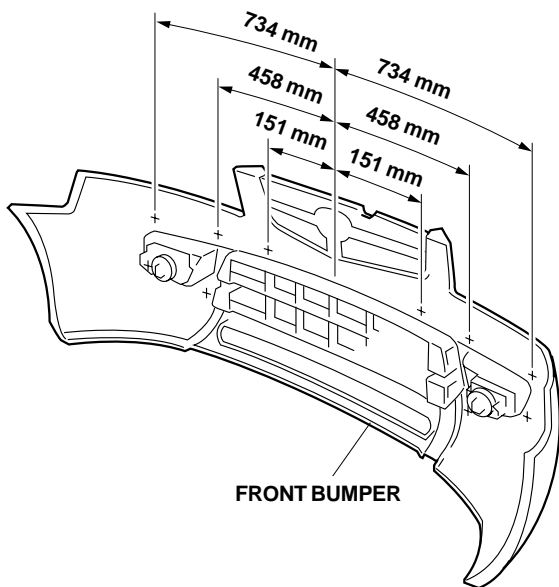

- While wearing eye protection, drill a 3 mm pilot hole and then a 10 mm hole through each of the 10 center-punched marks.

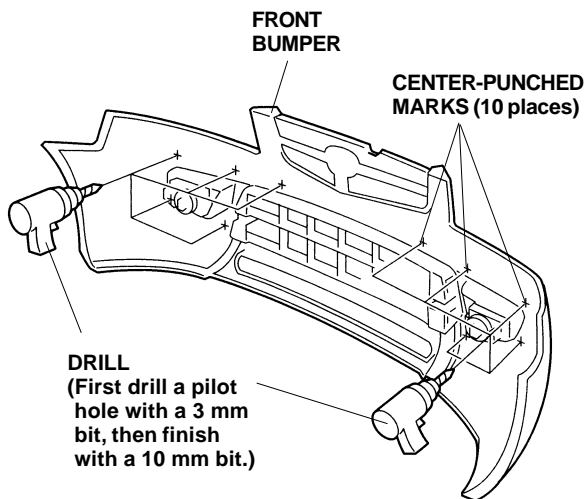

- After drilling holes, remove all burrs from the edges of the 10 mm holes with a file.

- Align the center line on the bumper trim with the center line on the front bumper, and install the six long stepped bolts and four short stepped bolts.

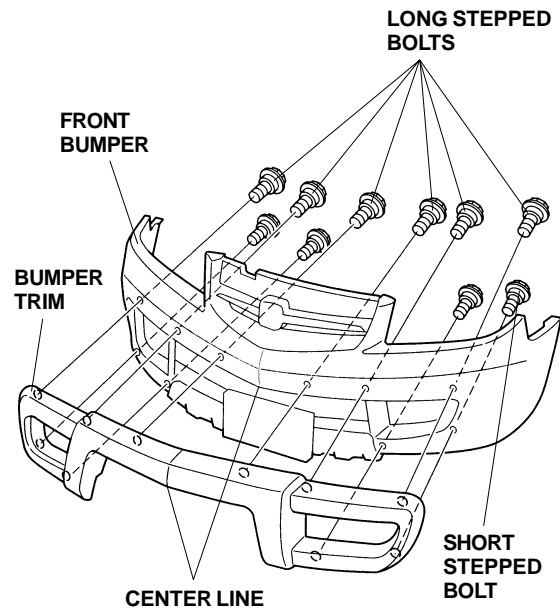

- Reinstall the front bumper.