

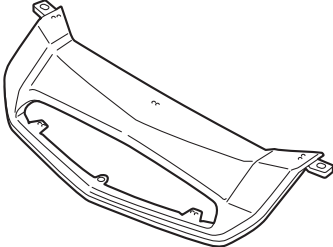



ACURA
INSTALLATION
INSTRUCTIONS

Accessory	Application	Publications No.
FRONT LOWER TRIM	MDX	BII 33258
		Issue Date
		OCT 2006

NOTE: A nose mask cannot be installed on a vehicle equipped with a front lower trim.

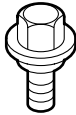
PARTS LIST

- Front lower trim 
- Bolt A 
- Washer nut 
- 3 Flange bolts (6 x 12 mm) 
- 2 Special nuts (if equipped, not used) 
- 2 Bolts C (6 x 25 mm)
(if equipped, not used) 

TOOLS AND SUPPLIES REQUIRED

- Phillips screwdriver
- Flat-tip screwdriver
- Drill
- 3 mm, 6 mm, and 10 mm Drill bits
- Pushpin
- Tape measure
- Eye protection (safety goggles, face shield, etc.)
- 10 mm Combination wrench
- Ratchet
- 10 mm Socket
- Blanket
- Utility knife
- Diagonal cutters
- File
- Felt-tip pen

INSTALLATION

Customer Information: The information in this installation instruction is intended for use only by skilled technicians who have the proper tools, equipment, and training to correctly and safely add equipment to your vehicle. These procedures should not be attempted by "do-it-yourselfers."

1. Make sure you have the anti-theft code for the radio and navigation system, then write down the radio presets.
2. Disconnect the negative cable from the battery.

3. Remove the front grille cover (8 clips).

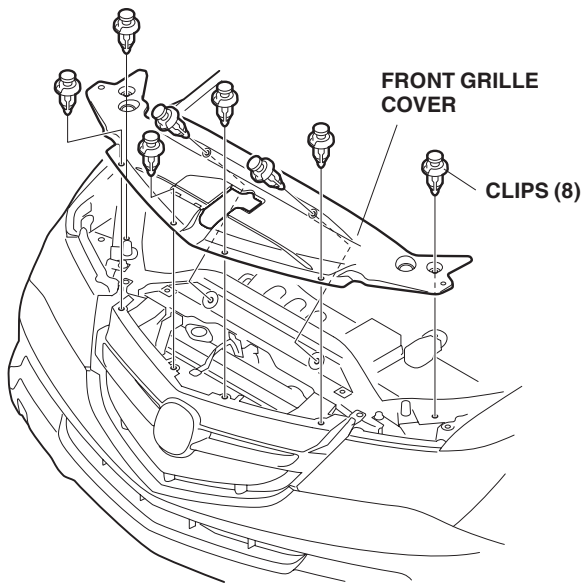

4. Remove the front bumper (2 self-tapping screws, 4 bolts, 11 clips, 4 connectors). Have an assistant help you when removing and installing the front bumper. Set the front bumper on a blanket.

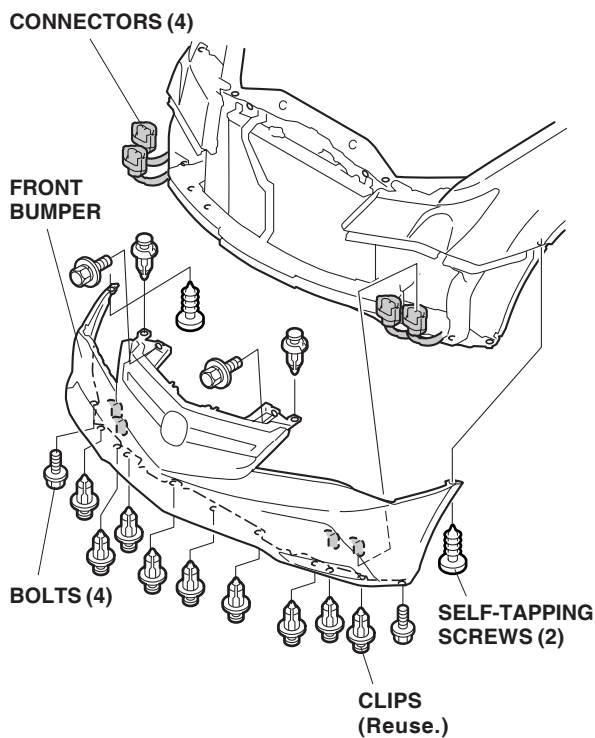

5. Inside the front bumper, locate the preset, towards the center of the bumper. Measure and mark the bumper at the measurement shown.

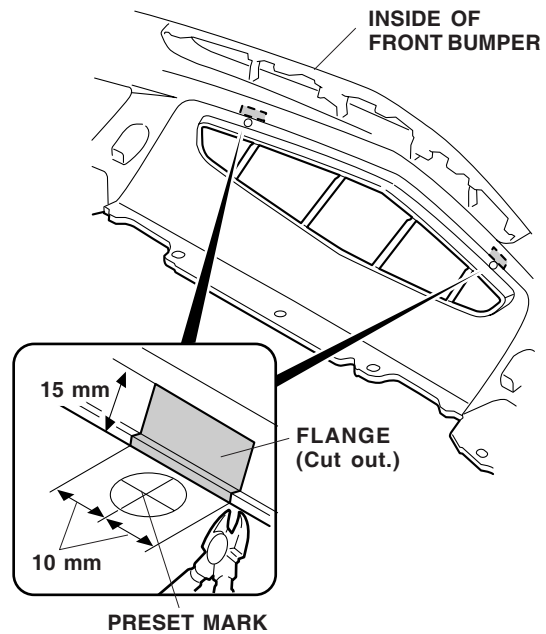

6. Using diagonal cutters, cut out the front bumper flange at the two places you just marked.
7. Inside the bumper, locate the six outboard preset marks. (The lower four marks are just small dimples.) Using a pushpin, pierce through the bumper at each outboard preset.

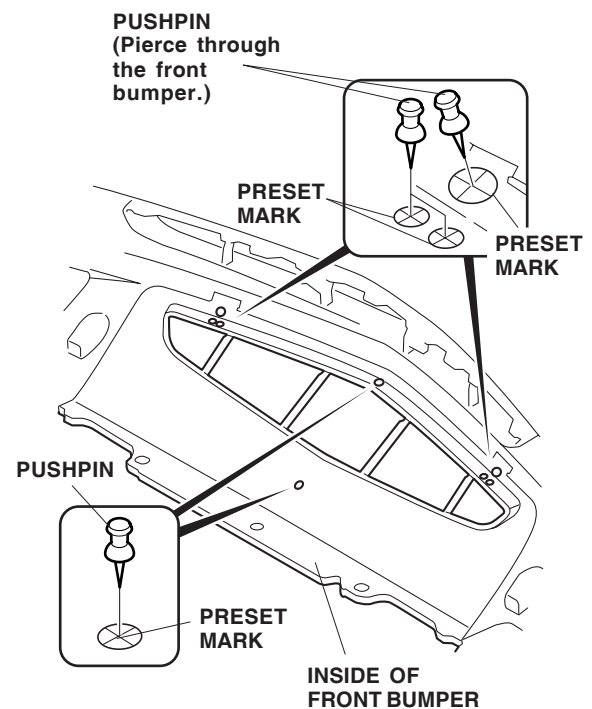

8. Inside the bumper at the center, locate the two preset marks. Using a pushpin, pierce through the bumper at each center preset mark.

9. While wearing eye protection, drill the four larger preset marks. First drill with a 3 mm drill bit, and finish with a 10 mm drill bit. Remove any burrs from the edges of the holes.

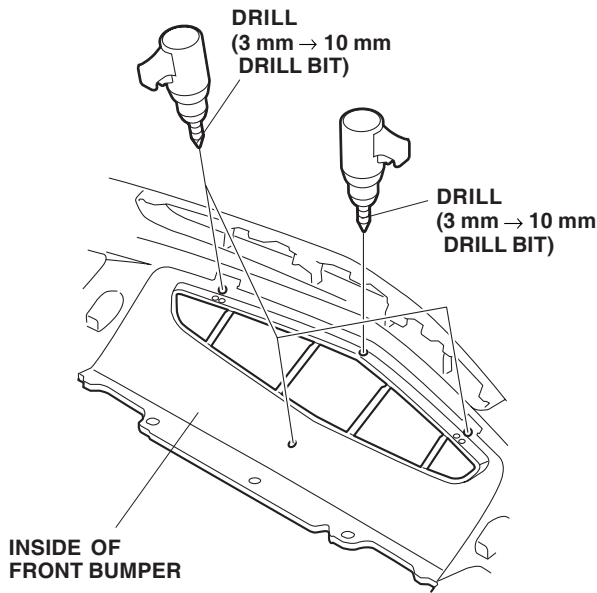

10. Outside the front bumper, drill the four dimpled preset marks. First drill with a 3 mm drill bit, and finish with a 6 mm drill bit.

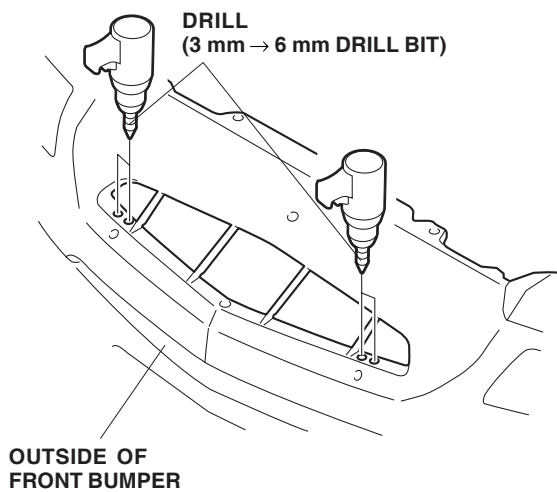

11. Position the front lower trim on the front bumper, and secure it with one bolt A and three flange bolts with washer nut.

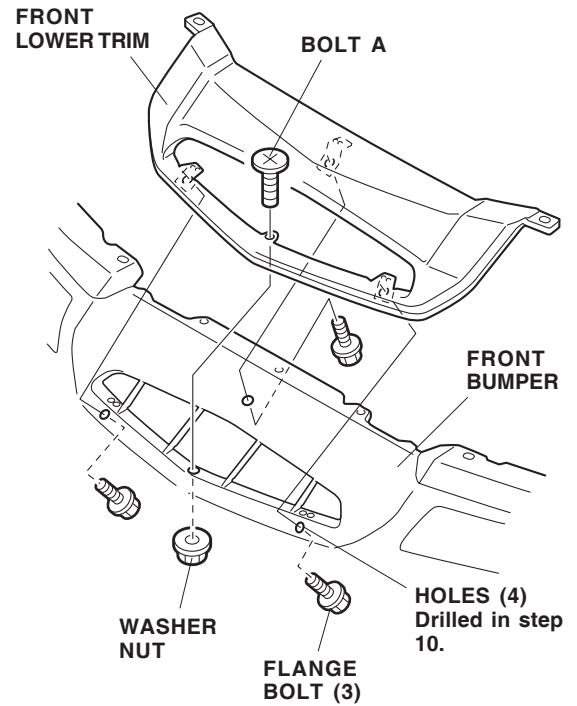

12. Reinstall the front bumper.

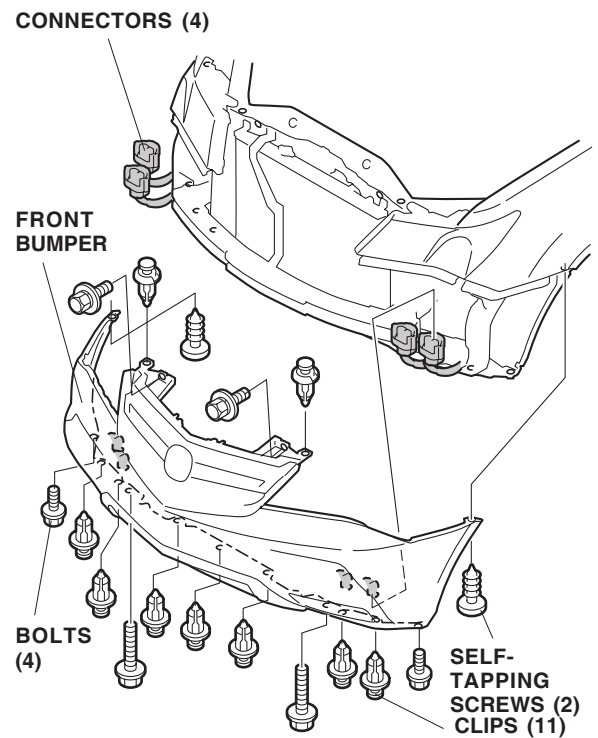

13. If installed, remove the front license plate holder from the bumper.
14. Measure and mark the inside of the front license plate holder 5 mm from the scribed line on each side. Using a utility knife, cut the bottom of the license plate holder along the area shown.

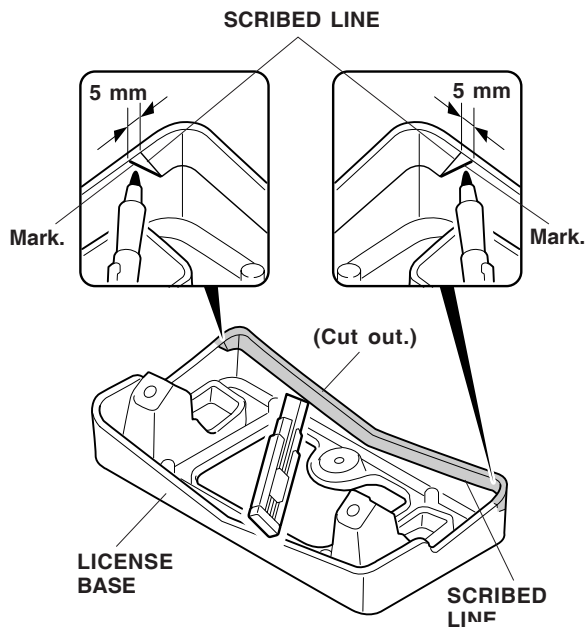

14. If necessary, install the two spring nuts into each hole in the front bumper grille.

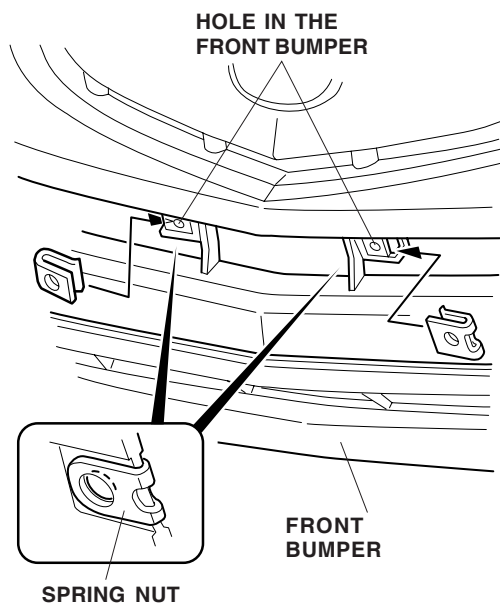

15. Install the vehicle license plate holder to the front bumper with the two bolts and one self-tapping screw.

