



ACURA INSTALLATION INSTRUCTIONS

Accessory
RUNNING BOARDS (SPORT)
P/N 08L33-STX-200C

Application
MDX

Publications No.
BII 32735
Issue Date
OCT 2006

PARTS LIST

Right running board

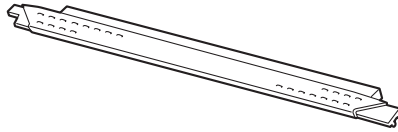

Left running board

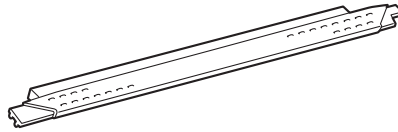

Right front end cap

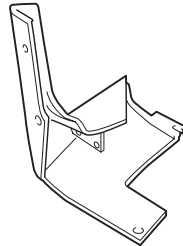

Left front end cap

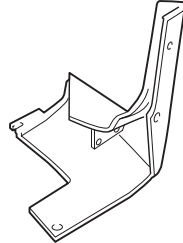

Right rear end cap

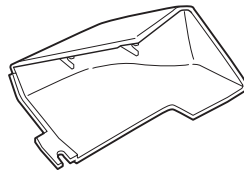

Left rear end cap

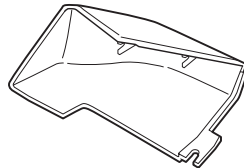

8 Self-tapping screws



4 Screws



4 Flange nuts, 6 mm



2 Brackets A

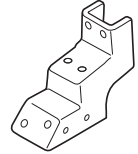

4 Brackets B

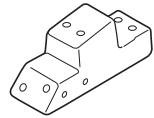

24 Flange bolts



12 Flange nuts, 8 mm



Right front inner end cap

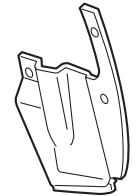

Left front inner end cap

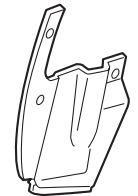

Right bracket C



Left Bracket C



2 Bumper bolts



TOOLS AND SUPPLIES REQUIRED

Ratchet
10 mm and 13 mm Sockets
10 mm and 13 mm Combination wrenches
Blanket
Torque wrench
Swivel socket
90 degree screwdriver

INSTALLATION

Customer Information: The information in this instruction is intended for use only by skilled technicians who have the proper tools, equipment, and training to correctly and safely add equipment to your vehicle. These procedures should not be attempted by "do-it-yourselfers."

NOTE:

- Thoroughly clean the bottom of the body between the front and rear wheels.
 - Be careful not to damage the body paint finish. To prevent damage, place a blanket under the running board during the installation.
 - These instructions show the left side running board being installed; the same procedure applies to installing the right running board.
1. Remove the left front splash guard (5 self-tapping screws).

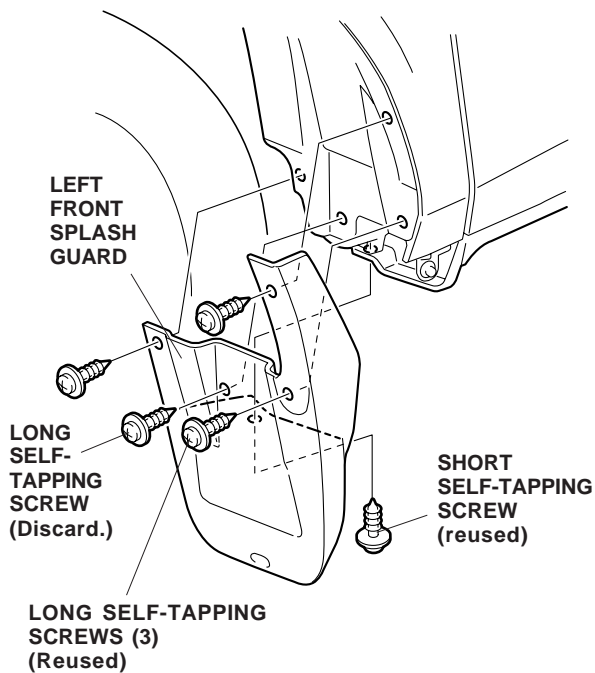

2. Install Bracket A and two Brackets B to the holes in the bottom of the side sill trim with the twelve flange bolts. Thread the flange bolts in about three or four turns.

NOTE: If there is undercoat on the body surface, remove the undercoat using a scraper or equivalent tool before installing the bracket A. If necessary, clean the threads using a tap. Take care not to damage the painted surface of the body.

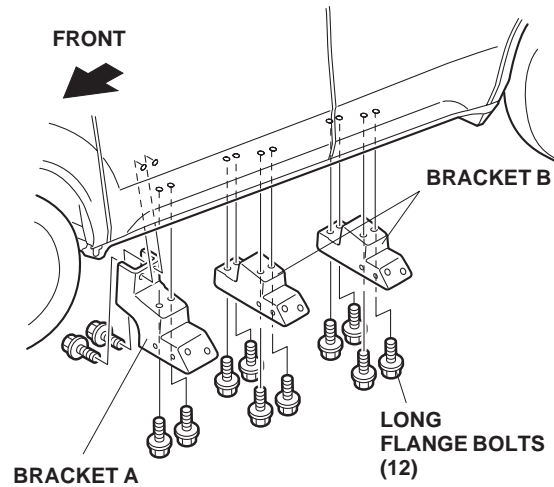

3. Install Bracket C (left) to the hole in the bottom of the left side sill trim by loosely tightening the short self-tapping screw you just removed.

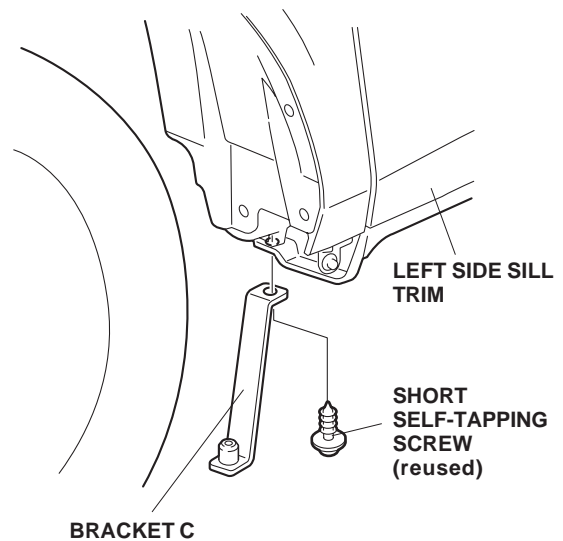

- Install the left front end cap and the left rear end cap to the left running board with the two self-tapping screws, one screw, and one flange nut.

FRONT

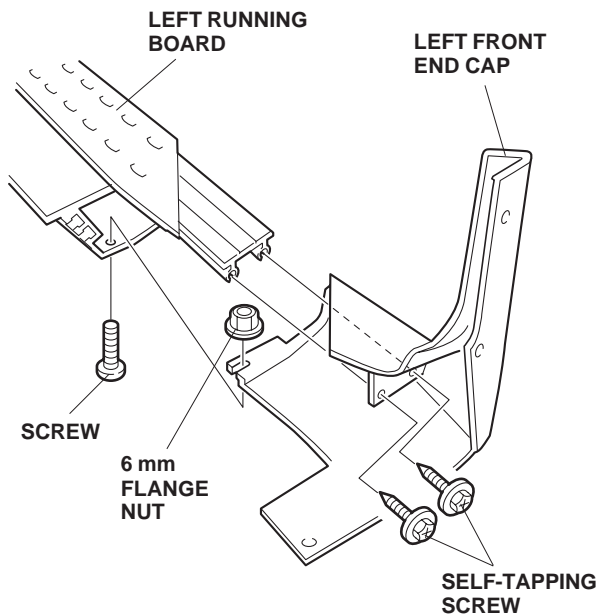

REAR

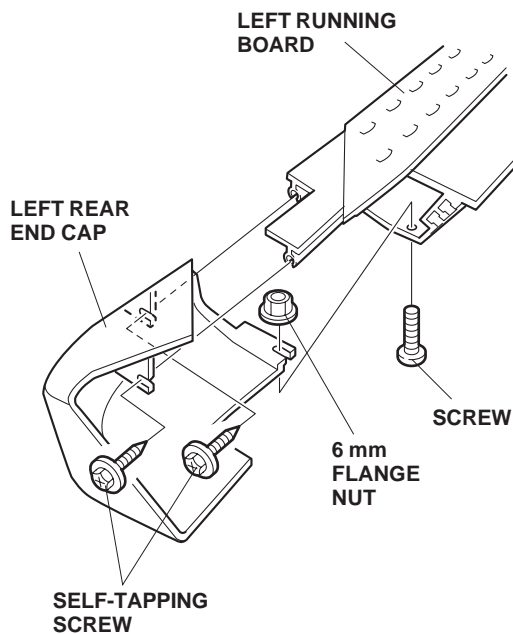

- Align the bolts on the left running board to the holes in the Brackets A and B you just installed on the side sill trim, and install it by loosely tightening the six flange nuts.

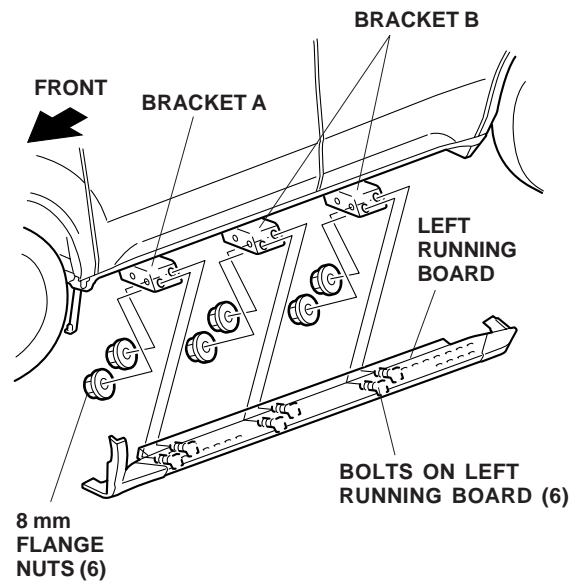

- Align the left inner end cap to the front of the left running board, and install it by loosely tightening the bumper bolt.

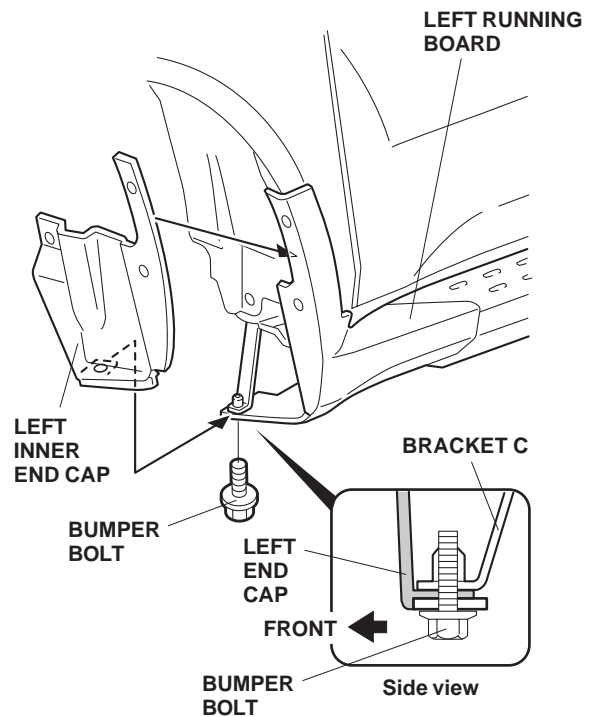

7. Secure the left inner end cap with the three long self-tapping screws.

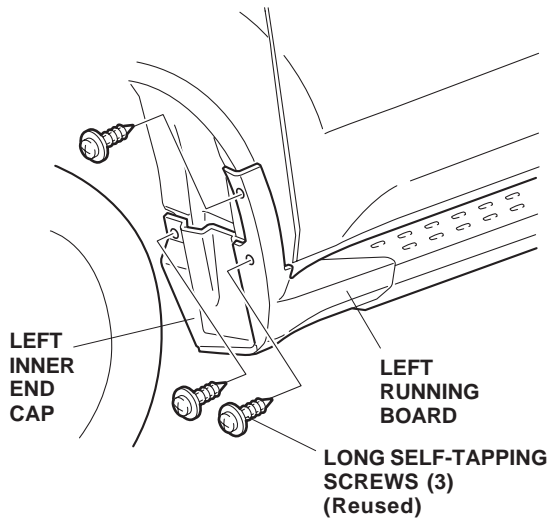

8. Secure all the bolts and nuts you installed. Torque the flange bolts to 27 N·m (20 lb-ft.)
9. Repeat steps 1 through 8 to install the right running board.