

**INSTALLATION
INSTRUCTIONS**

Accessory	Application	Publications No.
CD CHANGER ATTACHMENT KIT	S2000	All 26320
		Issue Date OCT 2003

PARTS LIST

**CD Changer Attachment Kit:
P/N 08B26-S2A-100A**

CD Changer bracket

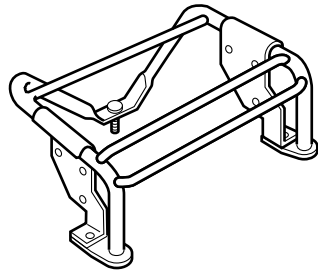

BUS cable

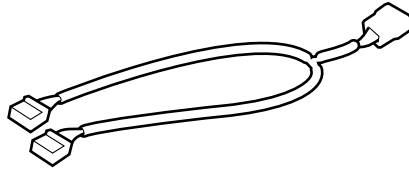

Butyl washer



7 Wire ties

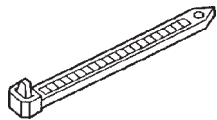

2 Cushion tapes

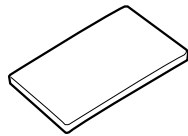

2 Jack nut



Special tool



2 Flange bolts



Nut



Plain washer



Template

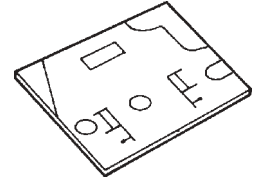

CD Changer cover

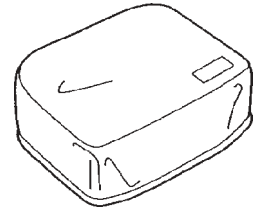

EPT sealer

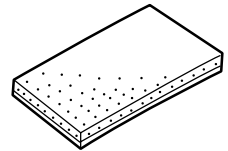

6 Washer-screws, 4 x 8 mm



Wire tie with clip
(for XM Radio equipped model only)

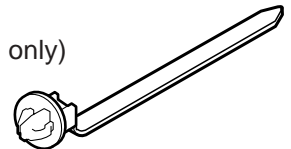

**CD Changer:
P/N 08A26-5E1-100**

CD changer

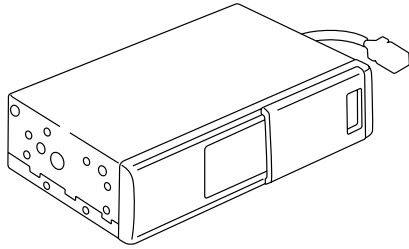

Side bracket

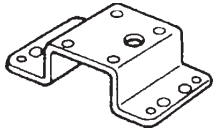

8-Disc CD magazine

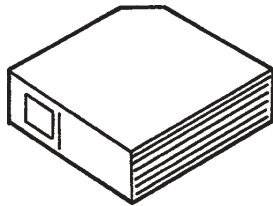

8 Washer-screws, 4 x 6 mm
(4 Not used)



Owner's Manual

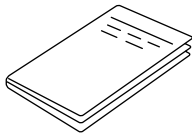

TOOLS AND SUPPLIES REQUIRED

- Phillips screwdriver
- 10 mm Socket
- Ratchet
- 10 mm Combination wrench
- Diagonal cutters
- Utility knife
- Tape measure
- Masking tape
- Felt-tip pen
- Drill
- 7 mm Drill bit
- 25 mm Hole saw
- Touch-up paint
- Awl
- Shop towel
- File
- Eye protection (face shield, safety goggles, etc.)

Illustration of the components installed on the car

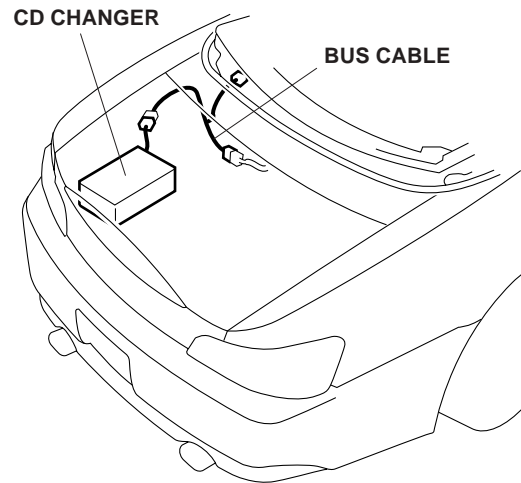

INSTALLATION

Customer Information: The information in this Installation Instruction is intended for use only by skilled technicians who have the proper tools, equipment, and training to correctly and safely add equipment to your vehicle. These procedures should not be attempted by "do-it-yourselfers."

1. Make sure you have the anti-theft code for the radio, then write down the radio station presets.
2. Disconnect the negative cable from the battery.

- Open the trunk lid and remove the tool tray. Remove all 12 clips and the two that secure the spare tire panel, and remove the panel.

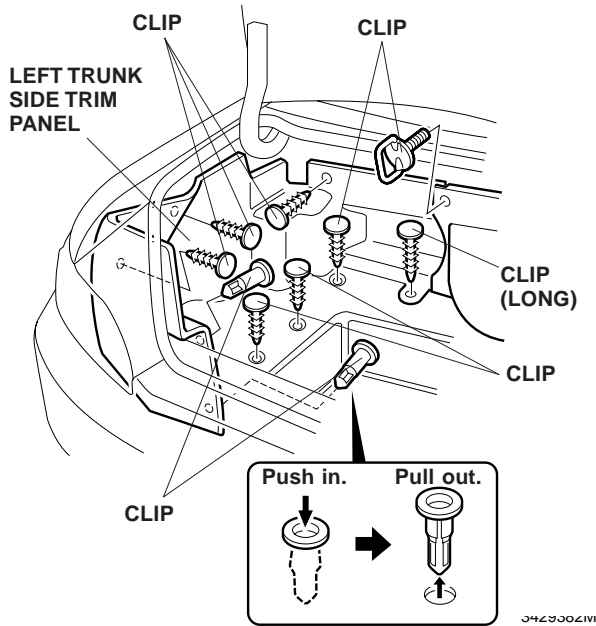

- Using a tape measure and a felt-tip pen, measure and mark the left trunk side trim panel; cut out the marked area from the panel with a utility knife.

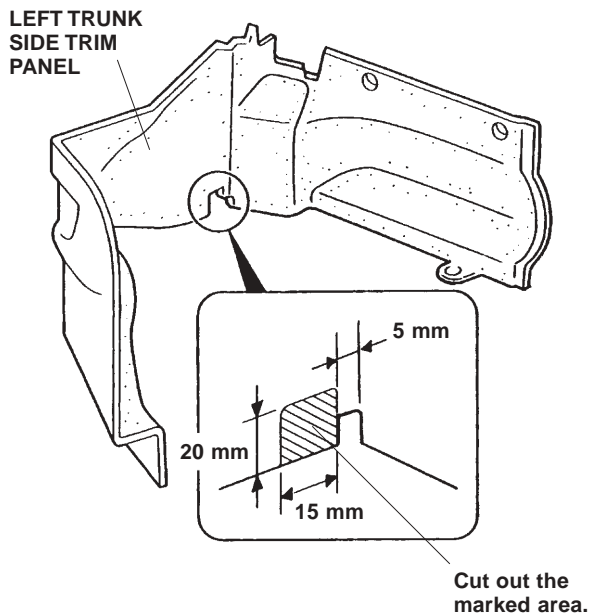

- Get the template. Using a utility knife, cut out all the round holes, rectangular holes, and slits in the template.

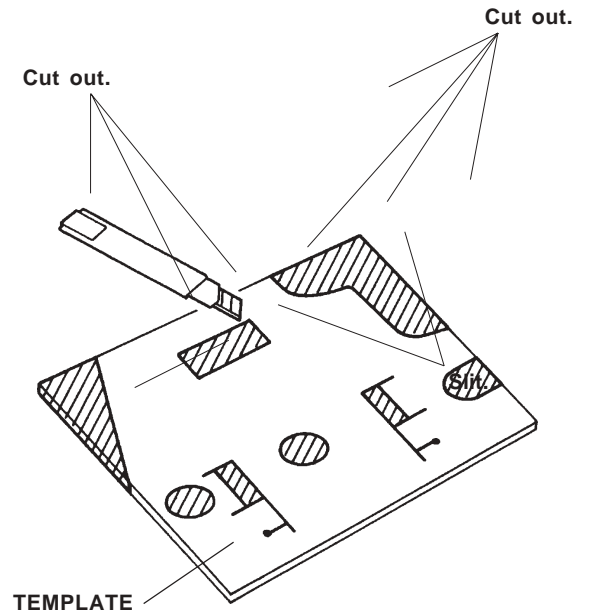

- Position the template by aligning the round holes in the template with the clip holes, then tape the template in place to the left of the trunk floor trim panel. Mark the edges of the rectangular holes and down all the slit lines on the panel with a felt-tip pen. Make the round marks, and remove the template.

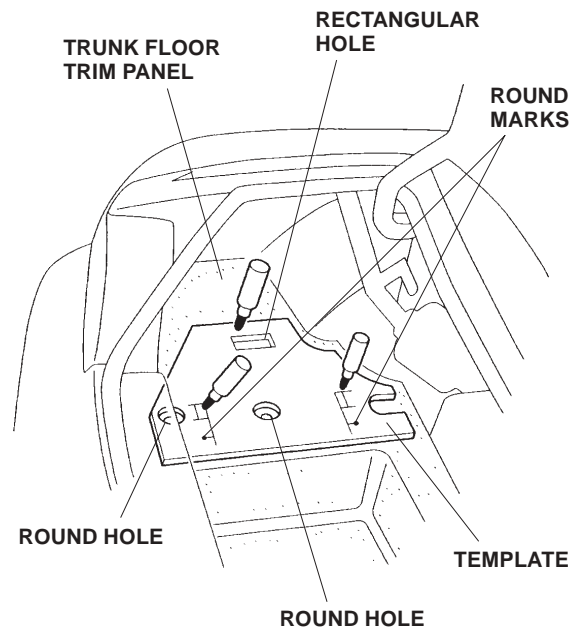

7. While wearing eye protection, lift up the trunk floor trim panel, and drill a 25 mm hole through each of the two marks you made in the panel. Drill the 25 mm holes only through the trunk floor trim panel, and not through the trunk floor panel.

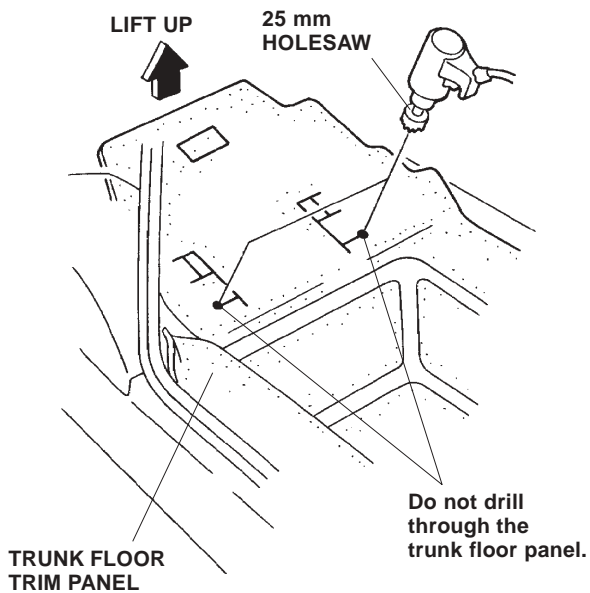

8. Using a utility knife, cut out the three marked areas from the floor carpet.

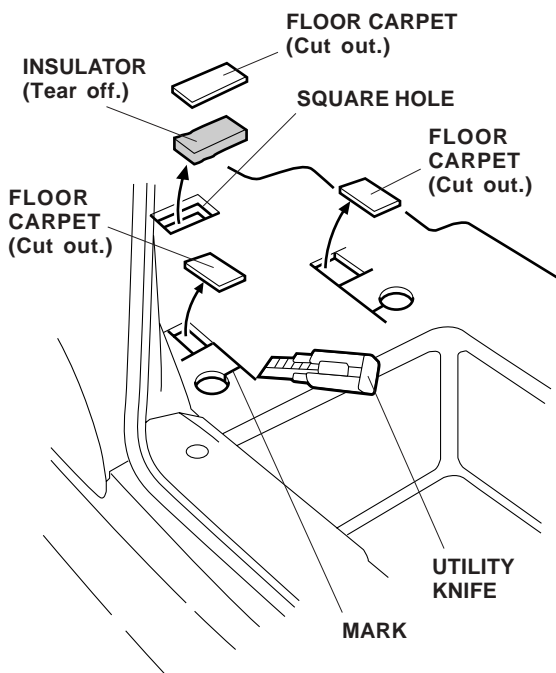

9. While wearing eye protection, drill a 7 mm hole through the recess on the floor panel. First drill with a 3 mm bit, and finish with a 7 mm bit.

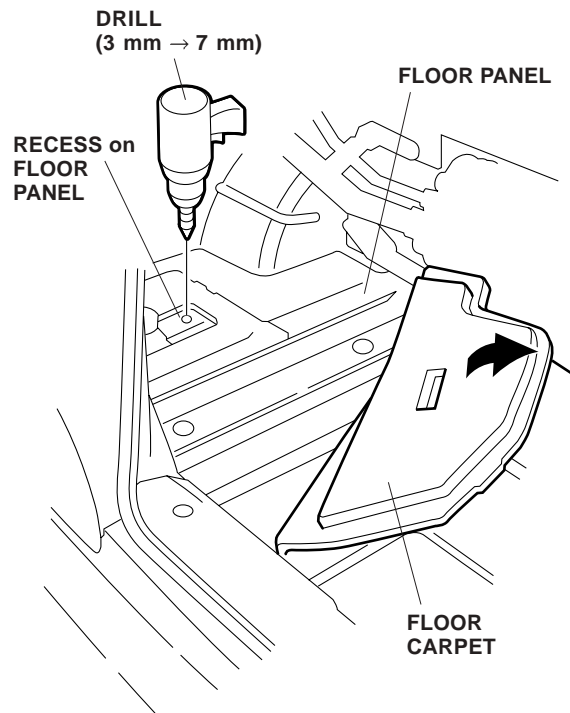

10. Remove the two grommets from the floor panel and install the jack nuts in the vacant holes.

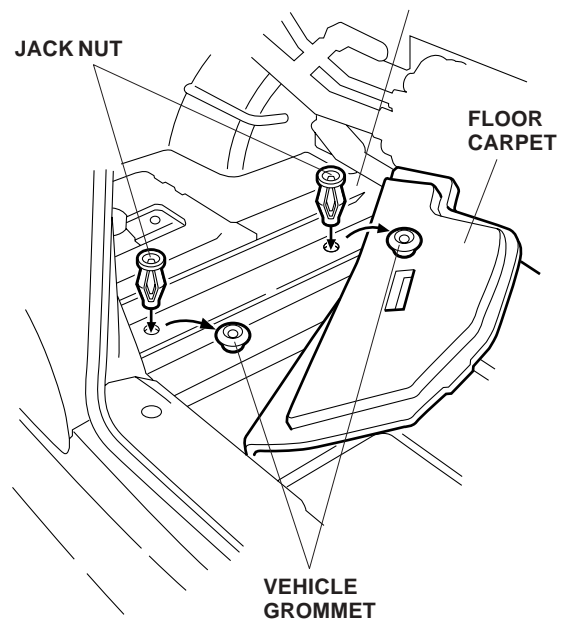

11. Locate the two holes in the trunk floor panel under the trunk floor trim panel where the slits were made. Insert a jack nut into each of the two holes in the trunk floor panel, and thread the flange-bolt into the jack nut with the tool provided:

- Bend the tool as shown before applying it to the flange-bolt.
- While holding the jack nut with the tool, tighten the flange-bolt to collapse the jack nut.
- Remove the flange-bolt.

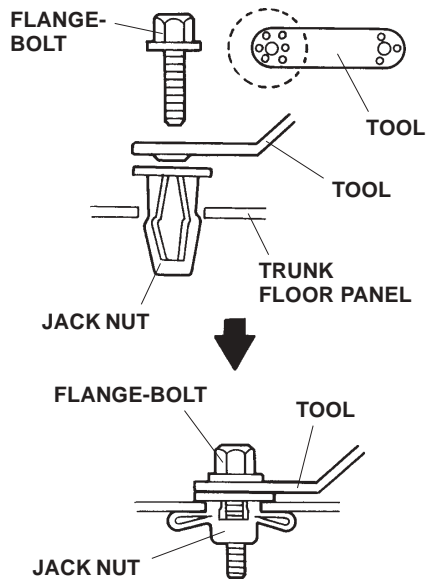

Installing the CD changer

12. Visually check the position of the spring adjusting slots on both sides of the CD changer. If both of the spring adjusting slots are not in the horizontal (H) position, move the slots to the horizontal position using a small flat-tip screwdriver.

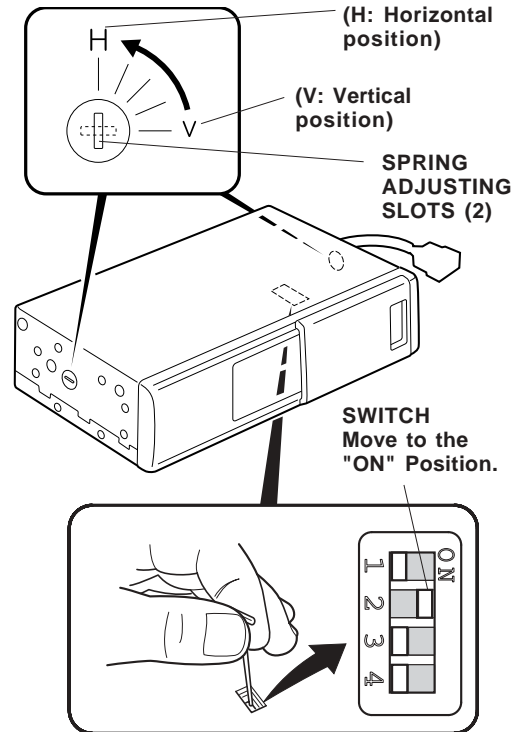

13. If the vehicle is equipped with an in-dash 6-disc CD Changer, use a pin to move the number 2 switch to the "ON" position.
14. Position the side bracket included in the CD changer and install the four 4 x 6 mm washer-screws also provided with the CD changer kit.

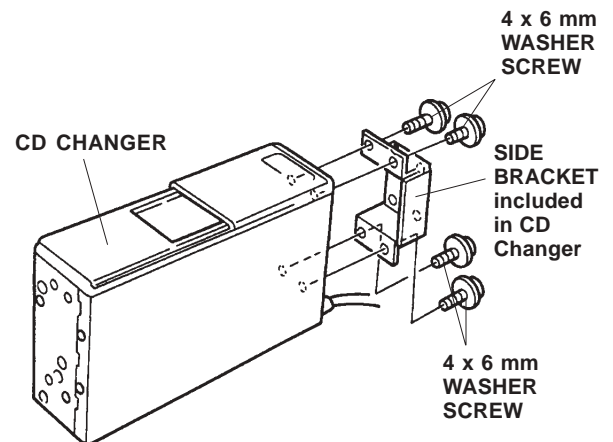

- Position the CD changer bracket on the CD changer and secure with the six 4 x 8 mm washer-screws.

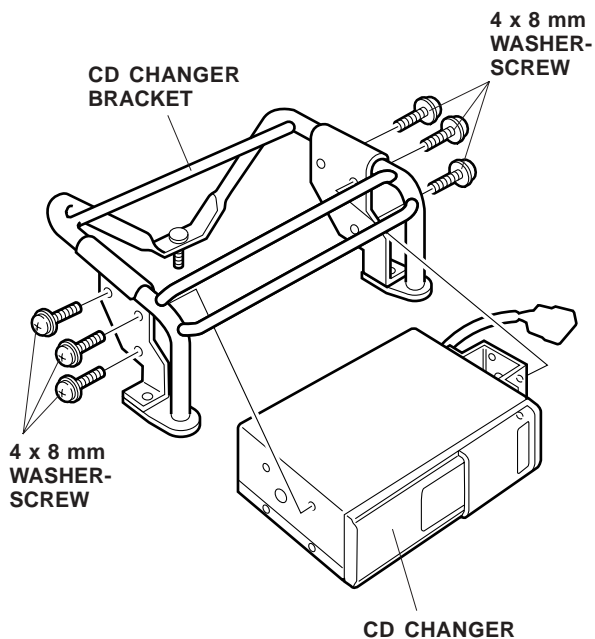

- Position the CD changer and bracket assembly on the trunk floor panel and install the two flange bolts from the inside, and a butyl washer, a plain washer and a nut on the end of the one stud bolt from the underside, as shown.

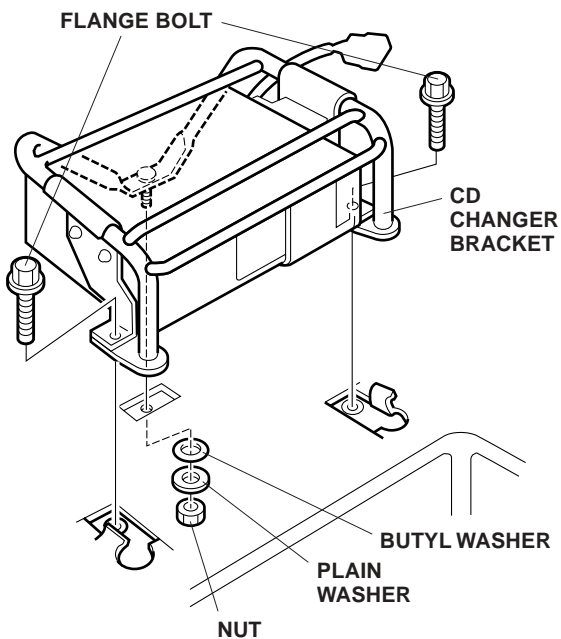

Routing the BUS Cable

If the vehicle you are working on is equipped with the XM radio, go to step 29. Otherwise; continue with *step 17*.

- Remove the vehicle clip with wire tie from the fuel tank.
- Inside the trunk, pull out the vehicle sub harness from the fuel tank by cutting the vehicle clip with wire tie. Take care not damage the vehicle harness when cutting the wire tie.
- Remove the tape from the vehicle sub harness and free the harness. Remove the dummy connector from the sub harness connector.

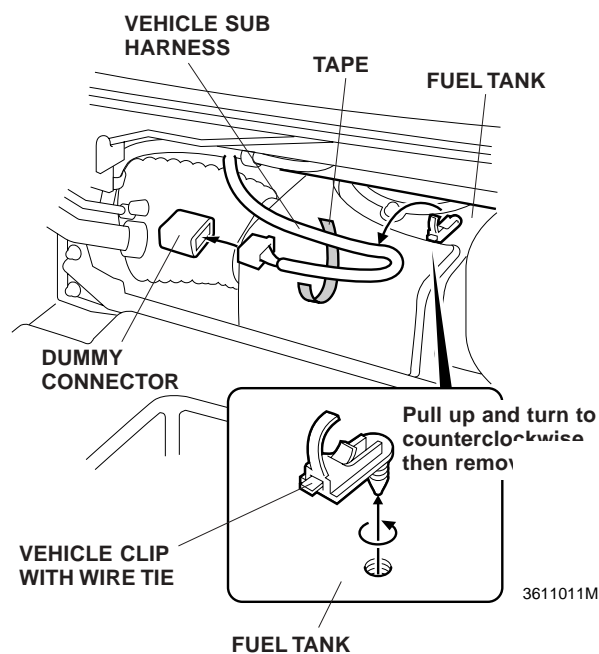

20. Connect the 14-pin connector of the BUS cable to the 14-pin connector of the vehicle sub harness.
21. Install the connector cap removed from the 14-pin connector of the vehicle sub harness in step 19 on the 14-pin connector of the BUS cable.

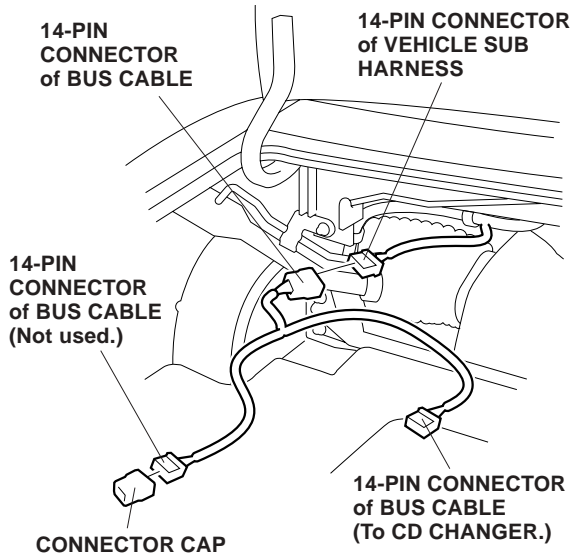

22. Route one branched portion of the BUS cable to the left along the vehicle harness, then connect the 14-pin connector of the BUS cable to the 14-pin connector of the CD changer.

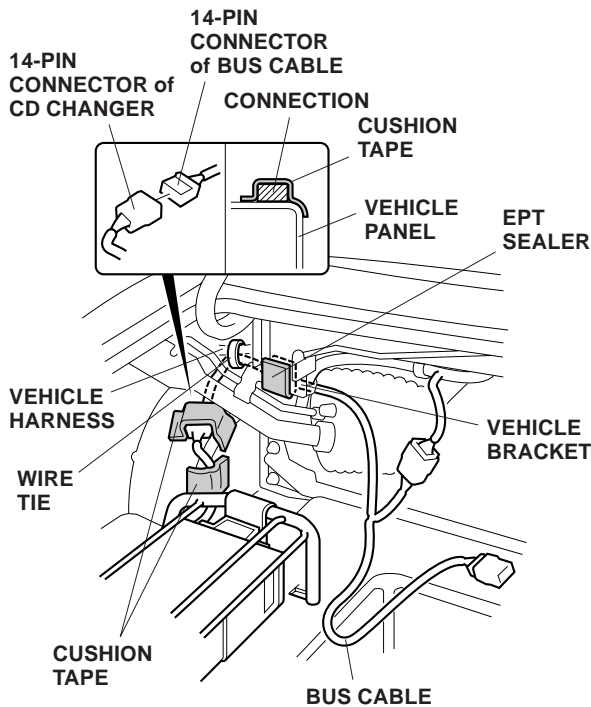

23. Secure the plugged connectors and CD changer cable to the vehicle panel with the two cushion tapes in the areas shown.
24. In the left of the trunk room to prevent the BUS cable from interfering with the bolt on the vehicle bracket, wrap the EPT sealer around the vehicle bracket. 25. Secure the BUS cable to the vehicle harness on the left of the vehicle bracket with the wire tie.
25. Secure the BUS cable to the vehicle harness on the left of the vehicle bracket with the wire tie.
26. Route the excess 14-pin connector of BUS cable along the vehicle harness as shown.

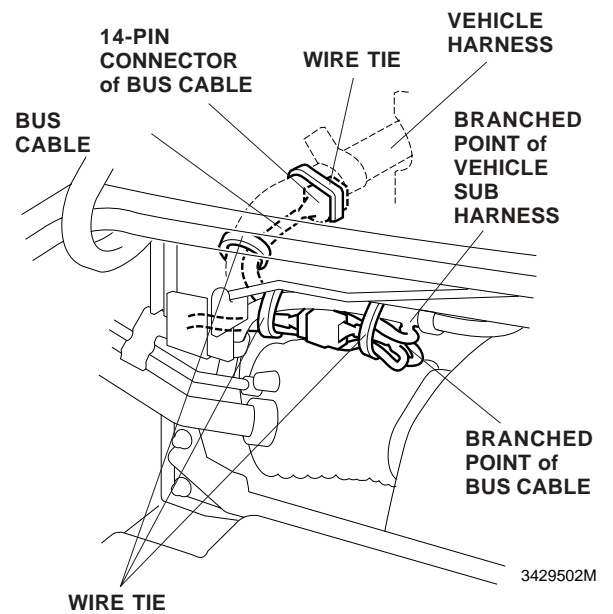

3429502M

27. Align the branched point of the BUS cable with that of the vehicle sub harness; then, make loops in the sub harness and secure them to the vehicle harness with the four wire ties.
28. Secure the 14-pin connector of the BUS cable to the vehicle harness with the wire ties.

If the vehicle is not equipped with an XM radio go to step 39. Otherwise, continue with step 29.

29. Loosen the two bolts that fasten the XM radio.

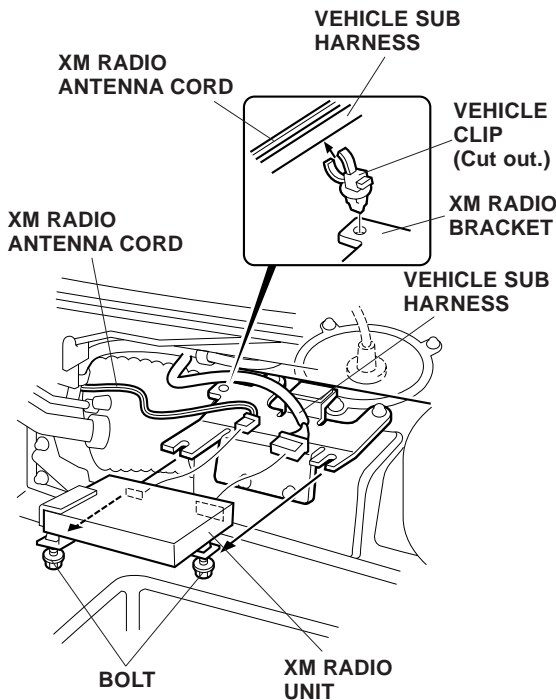

30. Pull the XM radio out toward you and release the vehicle clip fastening the vehicle sub harness and XM radio antenna cord from the XM radio bracket. Cut out the clip from the vehicle sub harness and XM radio antenna.
31. Unplug the vehicle sub harness and XM radio antenna cord from the rear of the XM radio unit.

32. Connect the 14-pin connector of the BUS cable to the 14-pin connector of the vehicle, sub harness, and connect the 14-pin connector of the BUS cable to the XM radio unit.

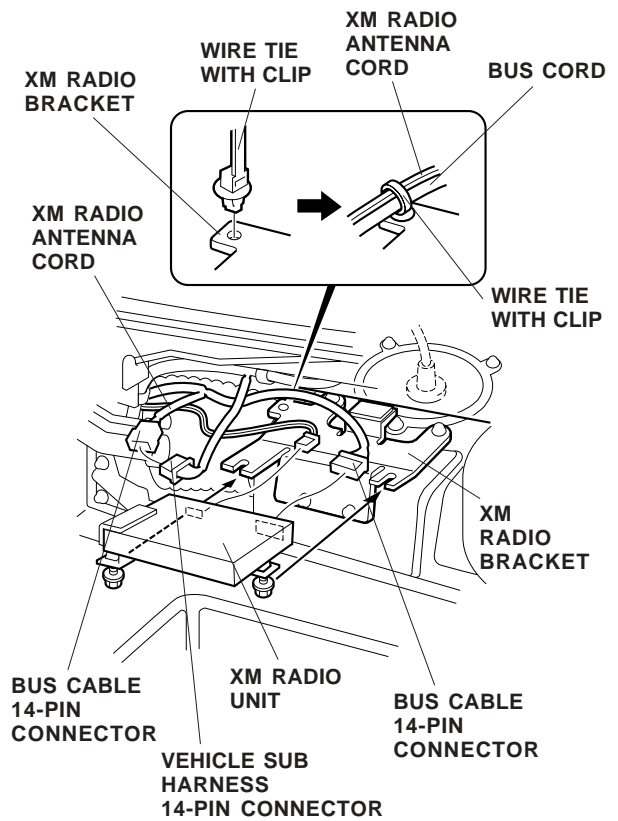

33. Plug the XM radio antenna jack into the rear of the XM radio unit, and secure it to the XM radio bracket with the wire tie with clip along with the BUS cable.
34. Reinstall the XM radio unit.

- Route one branched portion of the BUS cable to the left along the vehicle harness, then connect the 14-pin connector of the BUS cable to the 14-pin connector of the CD changer.

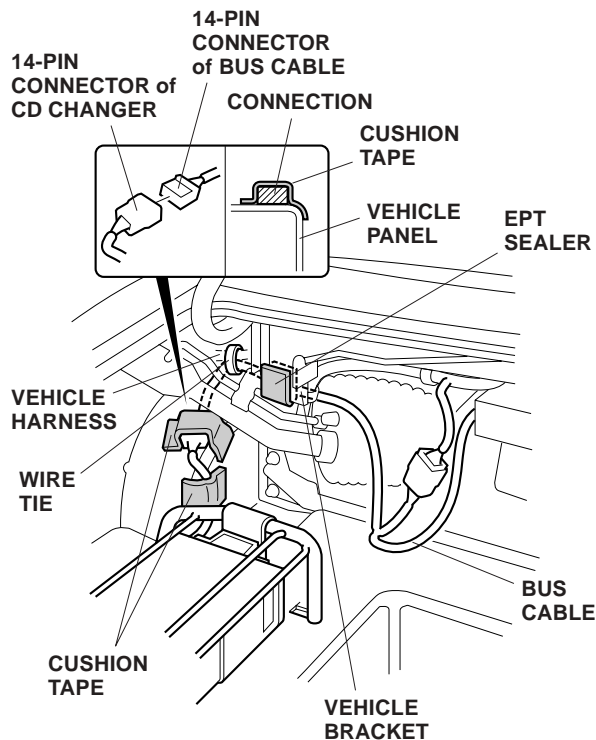

- Secure the plugged connectors and CD changer cable to the vehicle panel with the two cushion tapes in the areas shown.
- In the left of the trunk room to prevent the BUS cable from interfering with the bolt on the vehicle bracket, wrap the EPT sealer around the vehicle bracket.
- Secure the BUS cable to the vehicle harness on the left of the vehicle bracket with the wire tie.

- Align the branched point of the BUS cable with that of the vehicle sub harness, make loops in the BUS cable, and secure them to the vehicle harness with the two wire ties in the areas shown.

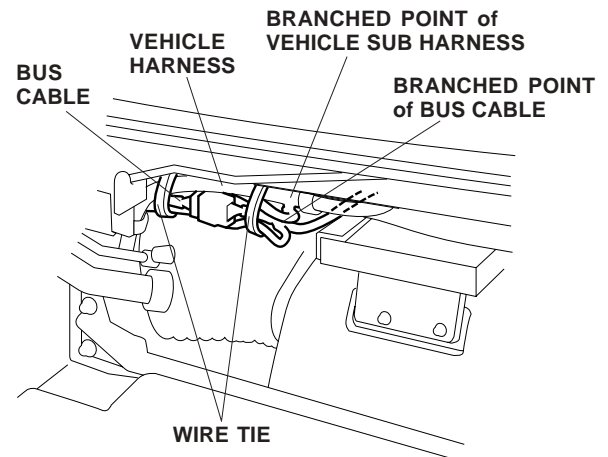

- Reinstall all removed parts.
- Check that all wire harnesses are routed properly and all connectors are plugged in.
- Reconnect the negative cable to the battery.
- Enter the customer's radio anti-theft code, and reset the radio station presets.
- Reset the clock.
- Place the CD changer cover over the CD changer.

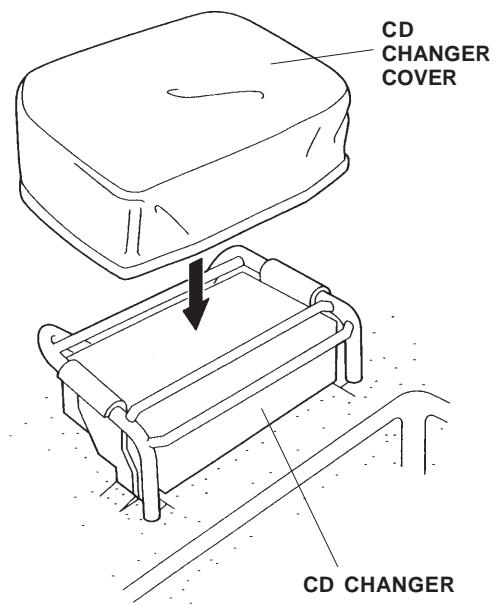

- Check operation of the CD Changer/Cassette Player according to the Owner's Manual provided.