

 <b>HONDA</b> <b>INSTALLATION</b> <b>INSTRUCTIONS</b>	Accessory	Application	Publications No.
	<b>CD CHANGER</b> <b>ATTACHMENT KIT</b>	2000 S2000	<b>All 20589</b> Issue Date <b>AUG 1999</b>

**PARTS LIST**

**CD Changer Attachment Kit:**  
**P/N 08B26-S2A-100**

CD Changer bracket

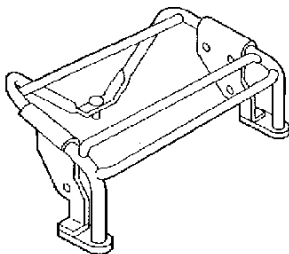

BUS cable

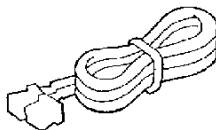

Butyl washer



3 Wire ties

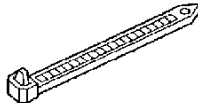

5 Cushion tapes

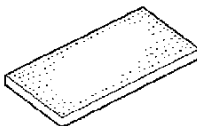

2 Jack nut



Special tool



2 Flange bolts



Nut



Plain washer



Template

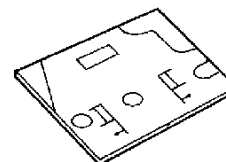

CD Changer cover

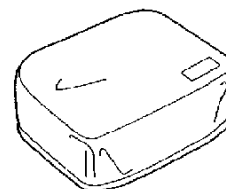

**CD Changer (sold separately):**  
**P/N 08A06-181-420**

CD Changer

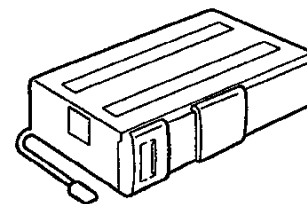

Owner's Manual



CD Magazine

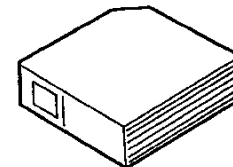

4 Washer-screws, 4 x 6 mm



Adhesive seal sheet

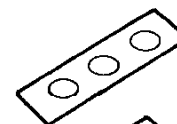

Locking covers

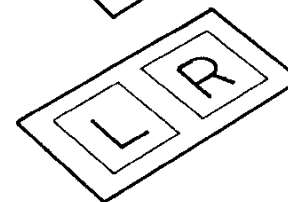

**TOOLS AND SUPPLIES REQUIRED**

- Phillips screwdriver
- Ratchet (10 mm Socket)
- Combination wrench (10 mm)
- Diagonal cutters
- Utility knife
- Tape measure
- Masking tape
- Felt-tip pen
- Electric drill motor (7 mm Drill bit)
- 25 mm Holesaw
- Touch-up paint
- Awl
- Shop towel
- File
- Eye protection (face shield, safety goggles, etc.)

**INSTALLATION**

**Customer Information:** The information in this installation instruction is intended for use only by skilled technicians who have the proper tools, equipment, and training to correctly and safely add equipment to your car. These procedures should not be attempted by "do-it-yourselfers."

1. Make sure you have the anti-theft code for the radio, then write down the frequencies for the preset buttons.
2. Disconnect the negative cable from the battery.
3. Open the trunk lid and remove the tool tray. Remove the ten clips securing the left trunk side trim panel and remove the panel.

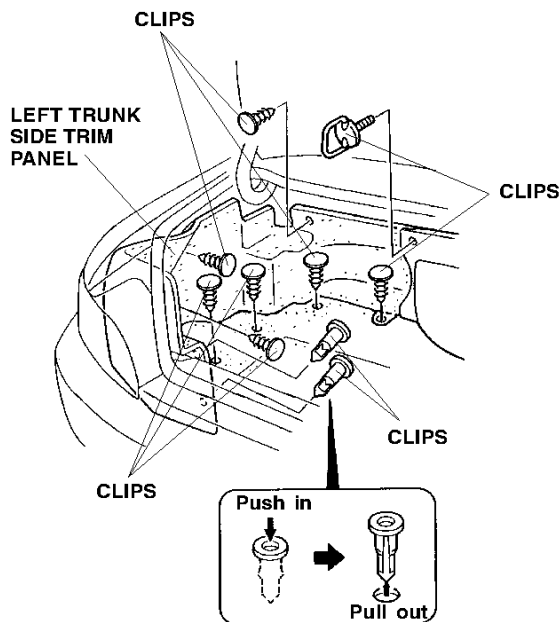

4. Using a tape measure and a felt-tip pen, measure and mark the left trunk side trim panel; then, cut out the marked area from the panel with a utility knife.

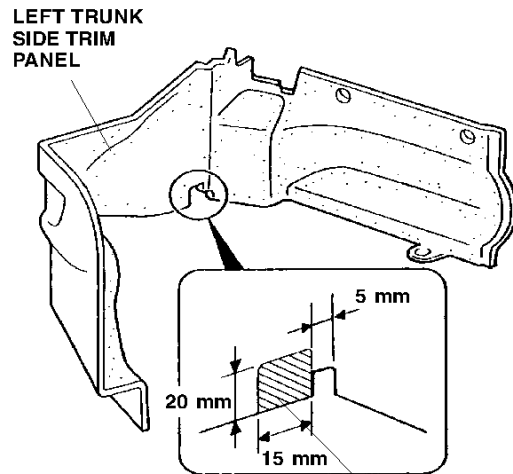

Cut out the marked area.

5. Get the template. Using a utility knife, cut out all the round holes, rectangular holes, and slits in the template.

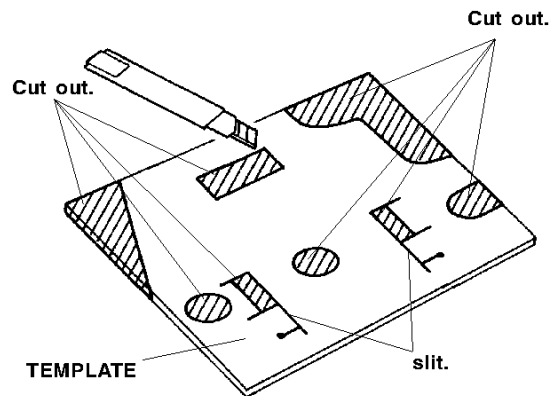

6. Position the template by aligning the round holes in the template with the clip holes, then tape the template in place to the left of the trunk floor trim panel. Mark the edges of the rectangular holes and down all the slit lines on the panel with a felt-tip pen. Make the round marks, and remove the template.

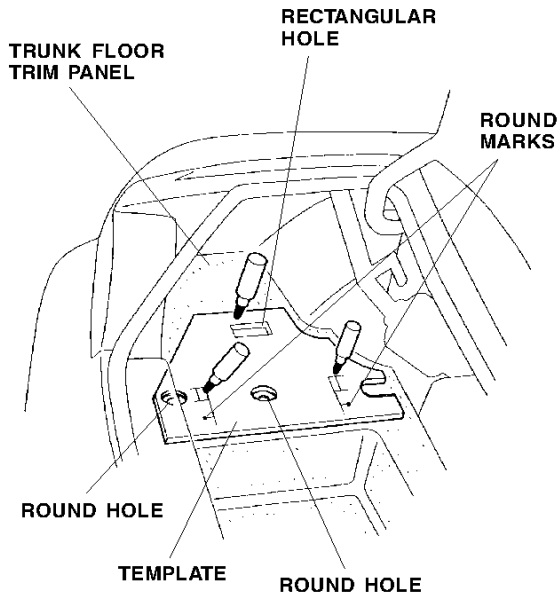

7. While wearing eye protection, lift up the trunk floor trim panel, and drill a 25 mm hole through each of the two marks you made in the panel. Drill the 25 mm holes only through the trunk floor trim panel, and not through the trunk floor panel.

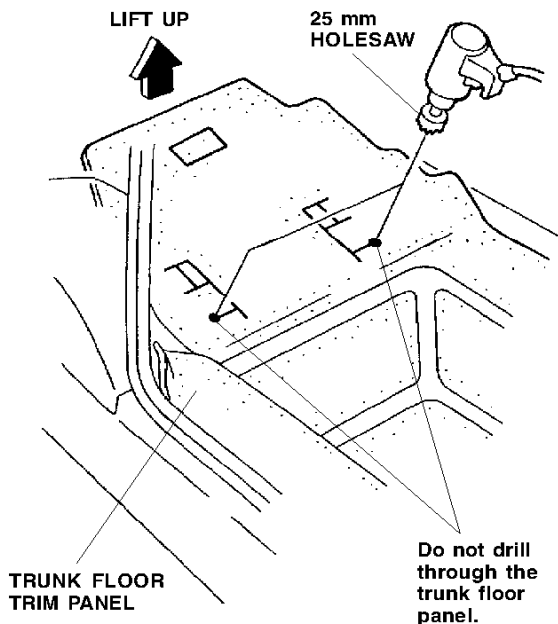

8. Using a utility knife, cut the trunk floor trim panel as indicated. Also cut out the marked area (rectangular section) from the left of the panel, and tear out the insulator concealed under the marked area of the panel.

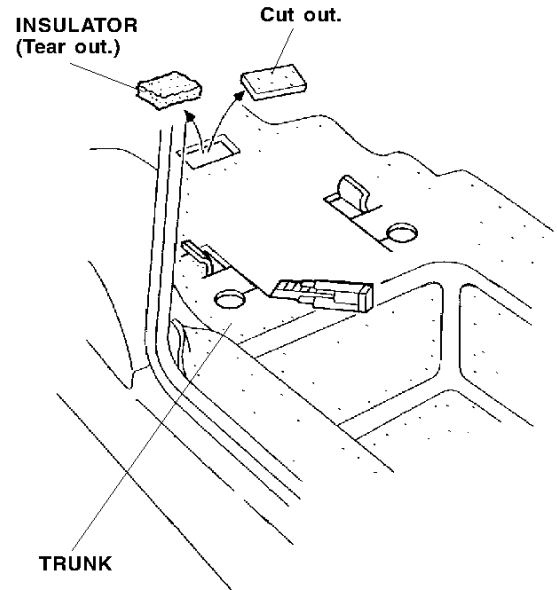

9. Locate a dimple in the trunk floor panel where the rectangular area was cut out in the previous step. While wearing eye protection, drill a 7 mm hole through the dimple inside the rectangular hole.

- Remove all burrs and apply touch-up paint.
- Clean the trunk compartment thoroughly.

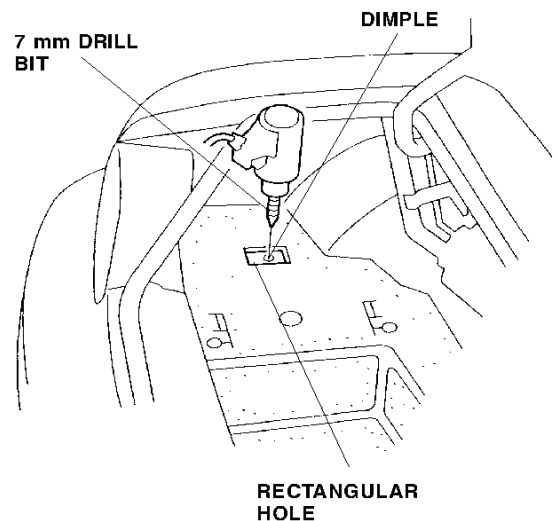

10. Also locate two holes in the trunk floor panel under the trunk floor trim panel where slits were made in step 8. Insert a jack nut into each of the two holes in the trunk floor panel.
- Install the jack nuts, as described on page 4 "Installing the Jack Nuts."
  - Reinstall three of the clips removed in step 3.

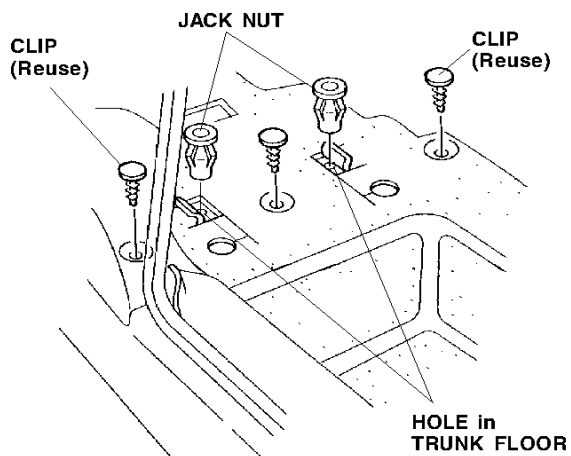

### Installing the Jack Nuts

11. With the jack nut installed into the hole, thread the flange-bolt into the jack nut with the tool provided.
- Bend the tool as shown before applying it to the flange-bolt.
  - While holding the jack nut with the tool, tighten the flange-bolt to collapse the jack nut.
  - Remove the flange-bolt.

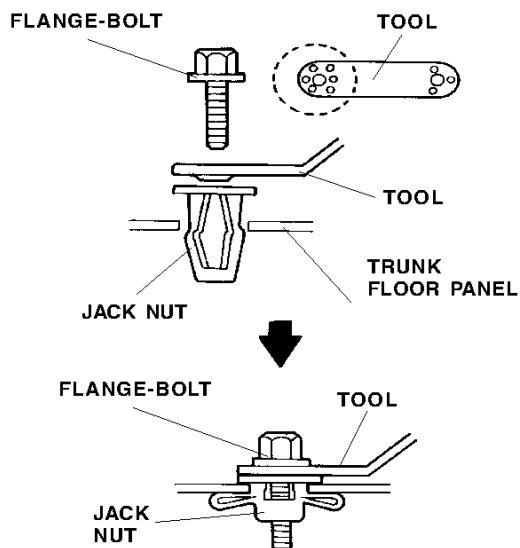

### Installing the CD Changer

12. Carefully unpack the CD changer. Remove the three shipping screws, and discard the shipping cover. Install a seal (included with the CD Changer Kit) over each of the three screw holes.

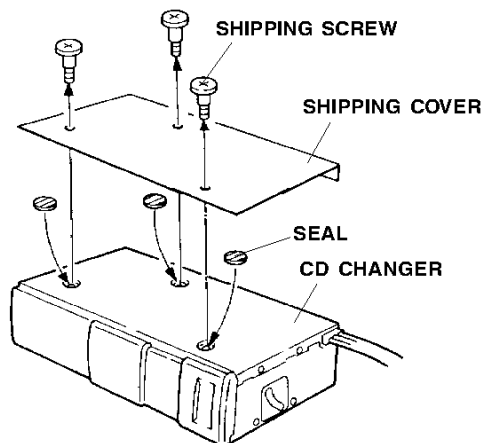

13. Visually check the position of the spring adjusting pins on both sides of the CD changer. The spring adjusting pins must be in the horizontal (H) position; if they are not in the horizontal position, move them with an awl.

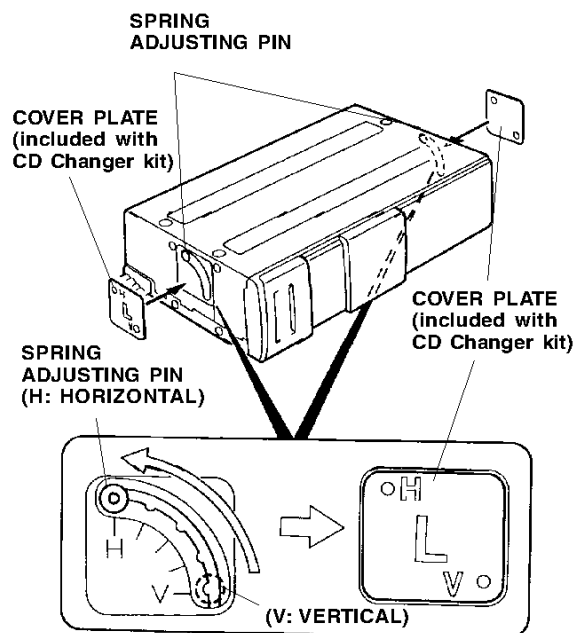

14. Position the CD changer into the CD changer bracket, and install the four washer-screws.

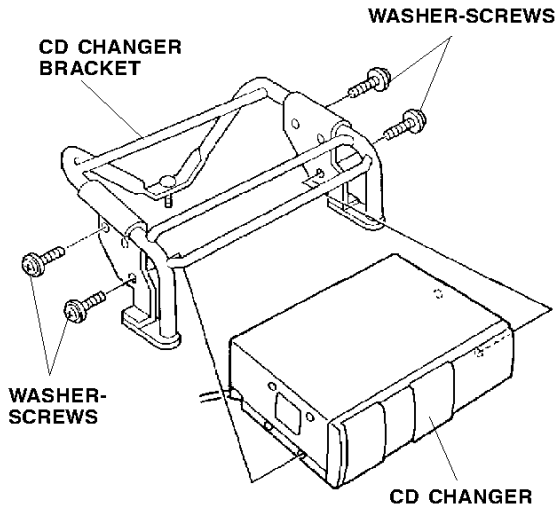

15. Inside the trunk, position the CD changer bracket assembly on the trunk floor panel, and install the two flange-bolts. From the underside of the trunk floor panel, install a nut, a plain washer, and a butyl ring on the end of each washer-bolt, and tighten the nuts securely. Route the harness between the changer and the bracket.

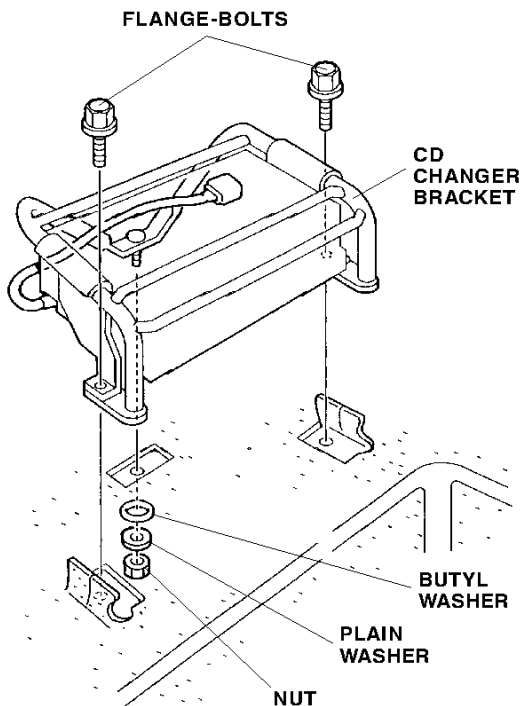

### Routing of the Bus Cable

16. Using a flat-tip screwdriver, pry up on the seven clips, and remove the radio panel. Take care not to damage the clips and panels.

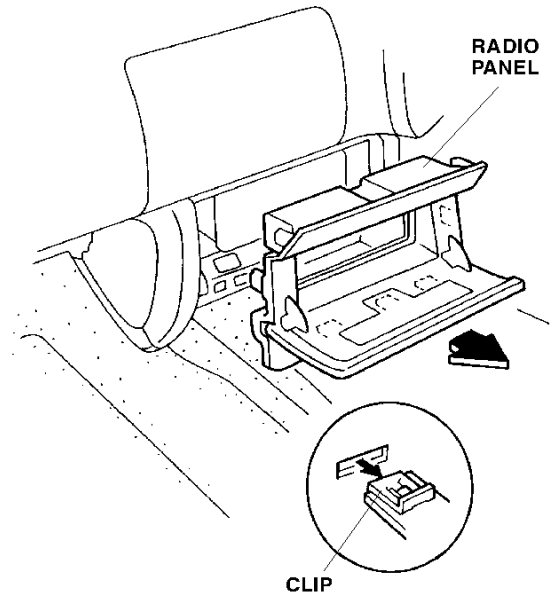

17. Remove the four self-tapping screws securing the radio, then pull the radio out toward you. Unplug the antenna lead and the 20-pin connector, and remove the radio.

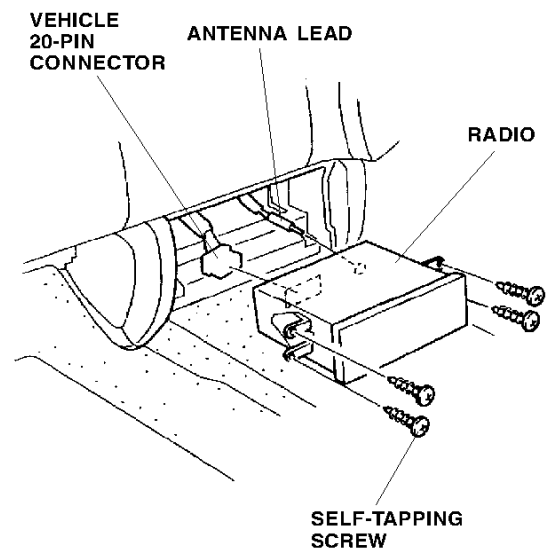

18. Remove the self-tapping screw securing the left front console cover, then remove the console cover. Take care not to damage the clips.

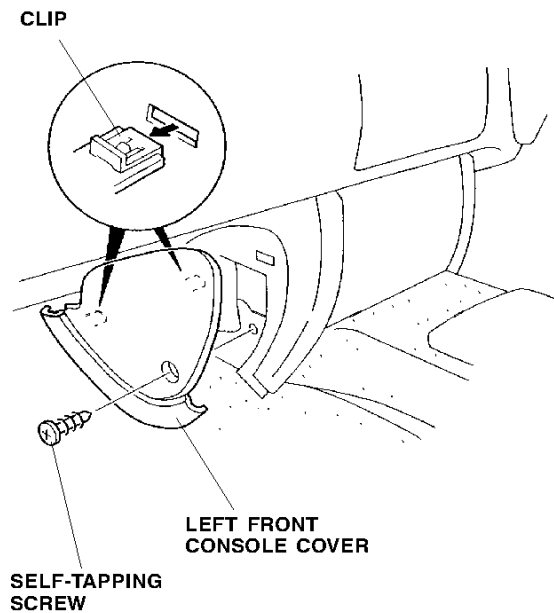

19. Remove the six clips securing the floor carpet under the left of the center console.

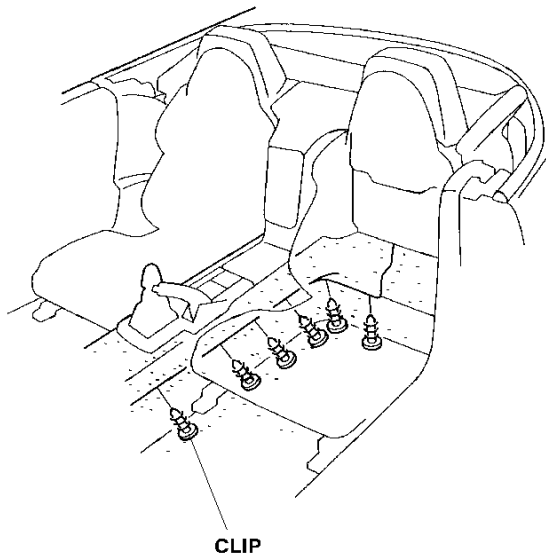

20. Tilt the driver's seat-back forward; then, open the caps and remove the hooks by removing the bolts.
21. Remove the driver's side roll bar lower trim (five clips).

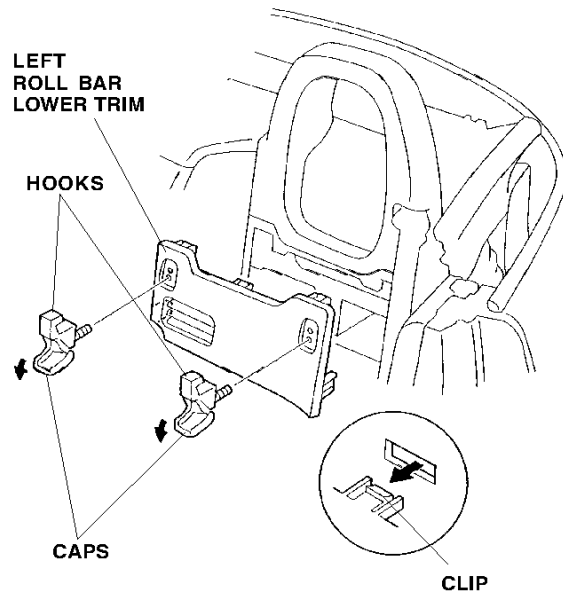

22. Route one end of the BUS cable behind the console bracket and out through the radio opening. Leave about 200 mm of BUS cable extending from the radio opening.
23. Plug the connector of the BUS cable into the rear of the radio.

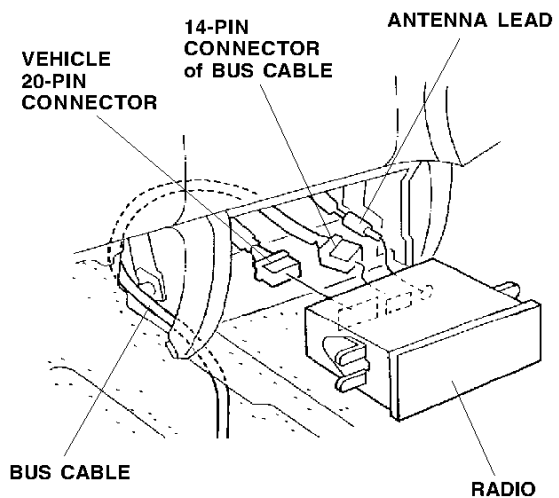

24. Plug the antenna lead and vehicle 20-pin connector into the rear of the radio, then reinstall the radio.

25. Route the BUS cable under the driver's side floor carpet and out through the hole where the driver's side roll bar lower trim was removed.
26. Route the BUS cable along the vehicle harness on the left side of the trunk compartment.

**HOLE**  
(where the driver's rear trim was removed)

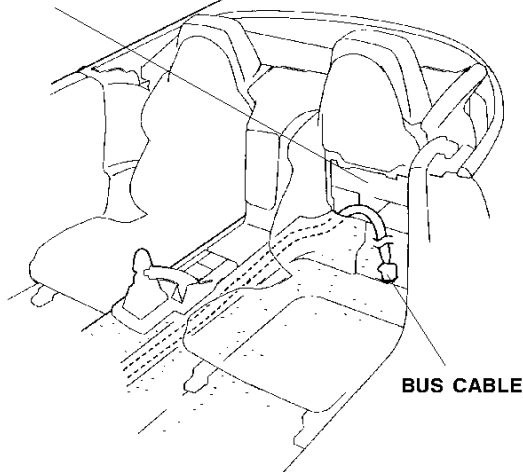

27. Plug the connector for the BUS cable into the connector from the CD changer.
28. Secure the BUS cable to the vehicle harness with the two wire ties in the areas shown.

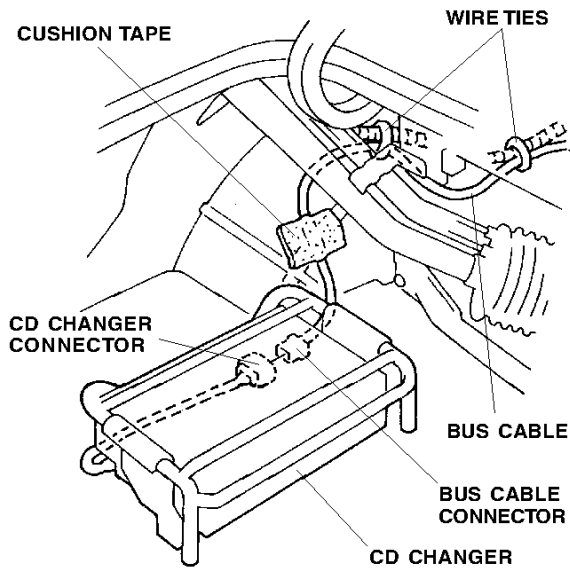

29. Using one cushion tape, secure the BUS cable to the wheelwell as shown.

30. Secure the BUS cable to the floor panel with four cushion tapes while moving the excess slack in the cable toward the rear of the vehicle.

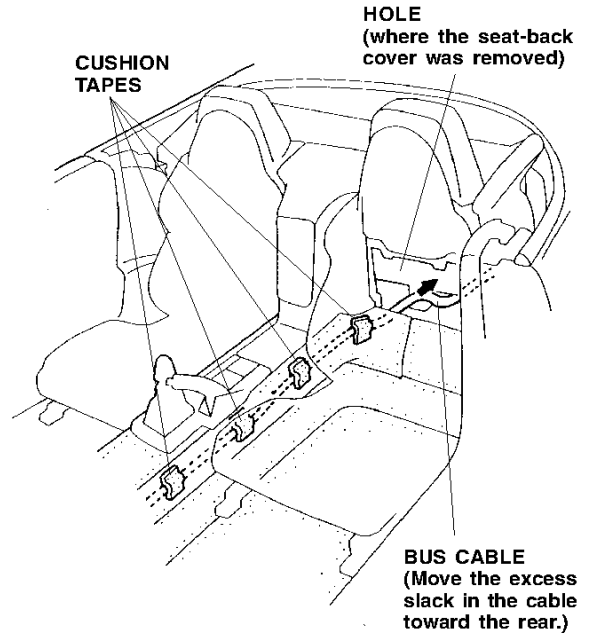

31. Fold the excess BUS cable behind the driver's seat-back where the driver's side roll bar lower trim was removed, then secure the cable to the heavy corrugated tube of the vehicle harness with one wire tie.

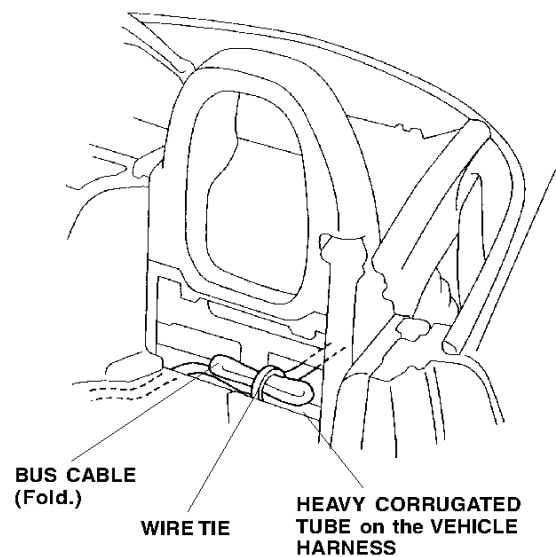

32. Place the CD changer cover over the CD changer.

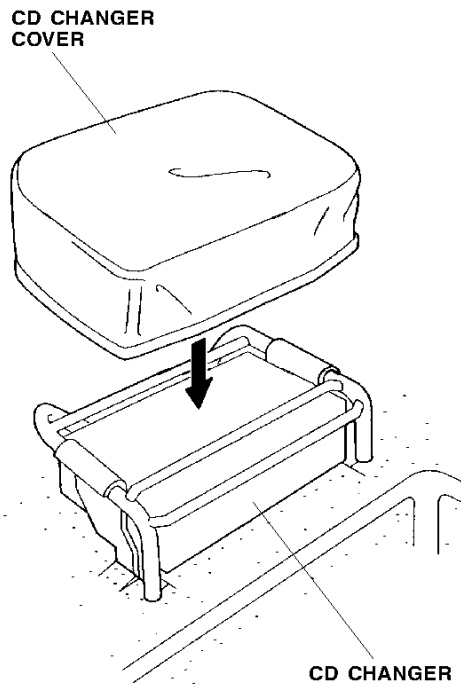

33. Reinstall all removed parts.
34. Check that all wire harnesses are routed properly and all connectors are plugged in.
35. Reconnect the negative cable to the battery.
36. Enter the customer's radio anti-theft code, and reset the radio station presets.
37. Check operation of the CD Changer/Cassette Player according to the Owner's Manual furnished with the unit.