 HONDA INSTALLATION INSTRUCTIONS	Accessory	Application	Publications No.
	TRUNK SPOILER	2000 S2000	All 20598 Issue Date AUG 1999

PARTS LIST

Trunkspoiler

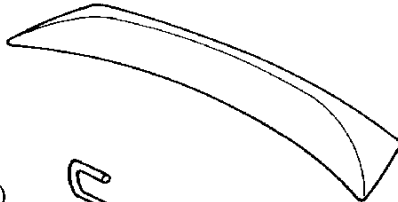

Right trunk spring
(with a sponge tube)

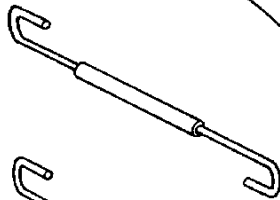

Left trunk spring

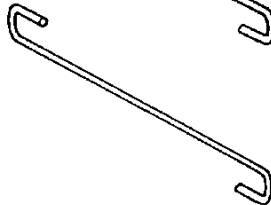

2 Cap nuts



2 Washer bolts



2 Butyl O-rings



4 Rubber washers



Marking washer set

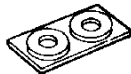

TOOLS AND SUPPLIES REQUIRED

- Shop towel
- Drill
- Eye protection (face shield, safety goggles, etc.)
- 3 mm, 6 mm, and 8 mm Drill bits
- File
- Center punch
- Touch-up paint
- Heavy gloves
- Trunk spring installer/remover
(P/N 08M10-SM4-100)
- Ratchet
- 6 mm Socket
- Torque wrench
- Hammer

INSTALLATION

Customer Information: The information in this installation instruction is intended for the use only by skilled technicians who have the proper tools, equipment, and training to correctly and safely add equipment to your car. These procedures should not be attempted by "do-it-yourselfers."

1. Wash and wax the area to be covered with a high-quality paste wax.

2. Inside the trunk lid, locate the identification hole on each side of the trunk lid. Center-punch each hole.

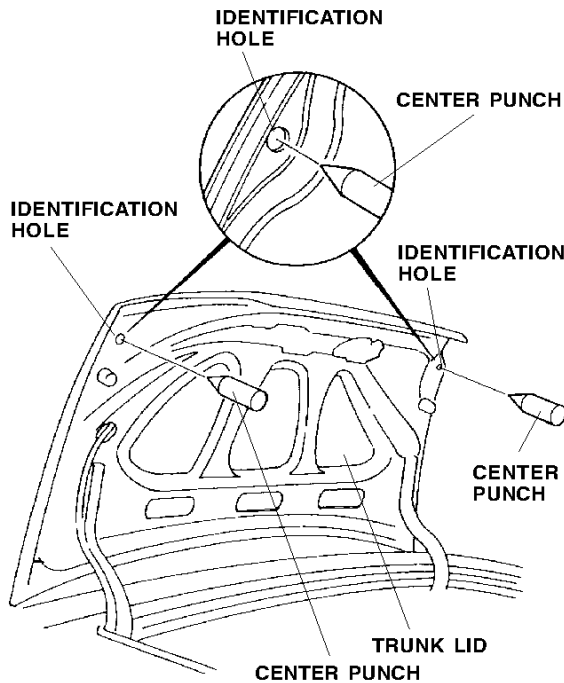

3. While wearing eye protection, drill an 8 mm hole through each center-punched mark:
 - Start with a 3 mm bit, then use a 6 mm bit, and finish with an 8 mm bit
 - Remove all burrs and apply touch-up paint.
 - Vacuum up any excess metal shavings.

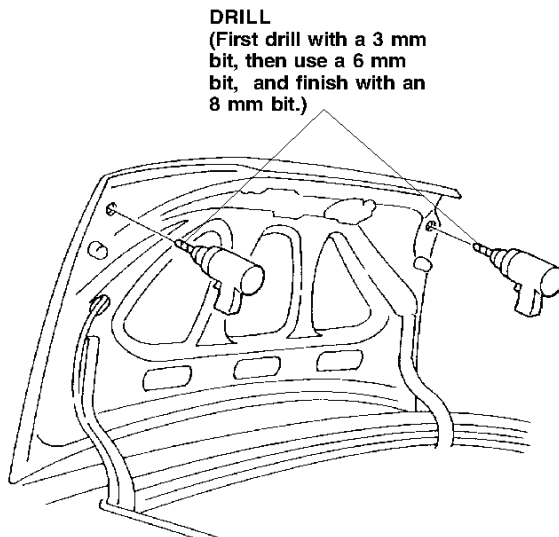

4. Remove the red adhesive backings from the two marking washers, and attach them to the trunk spoiler over the two screw holes.

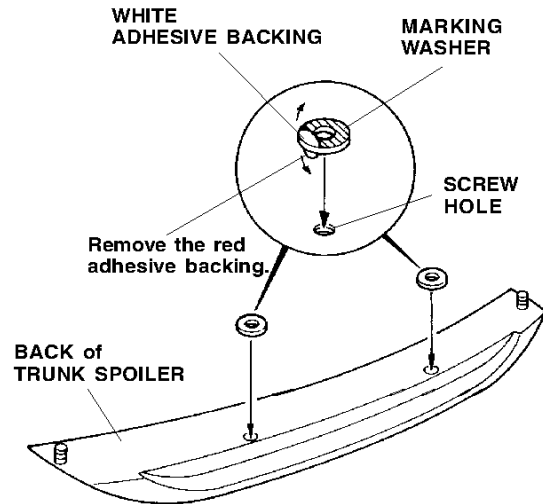

5. Remove the white adhesive backings from the marking washers. With the trunk lid closed, insert the studs from the trunk spoiler into the holes in the trunk lid.
6. Using the palm of your hand, press the trunk spoiler firmly against the trunk lid where the marking washers were attached.

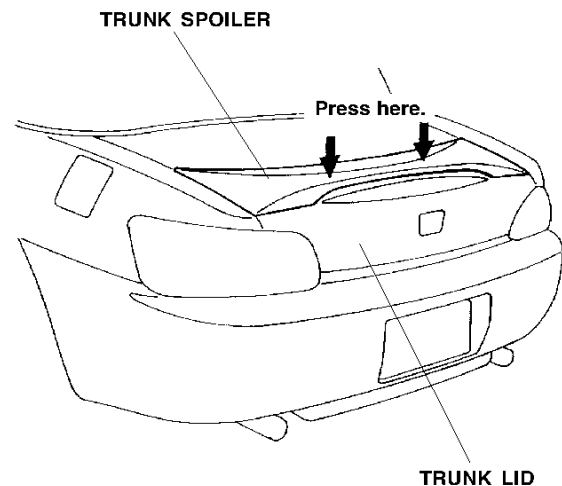

7. Slowly remove the trunk spoiler from the trunk lid. Check that the marking washers stay attached to the trunk lid.

8. Lightly center-punch the trunk lid at the center of each marking washer attached to the trunk lid, then remove the marking washers.

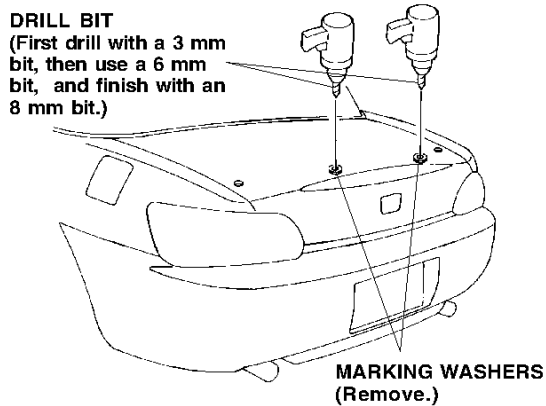

9. While wearing eye protection, drill an 8 mm hole through each center-punched mark:
- First drill with the 3 mm bit, then use a 6 mm bit, and finish with an 8 mm bit.
 - Remove all the burrs and metal shavings, and apply touch-up paint.
10. Remove the adhesive backings from the four rubber washers, and attach them over the four holes in the trunk lid.

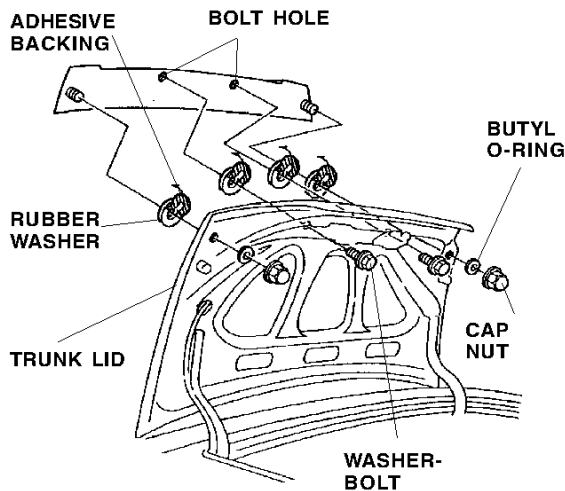

11. Fit the trunk spoiler into position on the trunk lid. Install a butyl O-ring and a cap nut on the end of each stud, but don't tighten the cap nuts yet.
12. Align the holes in the trunk spoiler with the holes in the trunk lid, and install the two washer bolts. Torque the cap nuts and washer bolts to 9 N•m (7 lb•ft).

13. Remove the spare tire cover (3 clips). Release the front portion of the left trunk side trim panel (3 clips), and pull the panel away from the trunk springs.

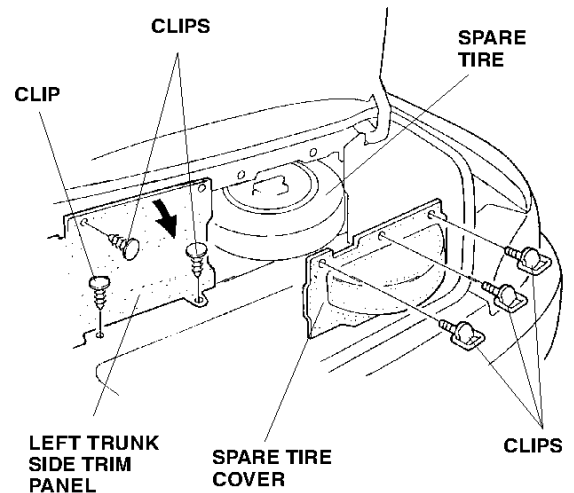

14. Have an assistant hold the trunk lid open. While wearing heavy gloves to protect your hands, remove the old trunk springs from the trunk hinge arms using the special tool. To prevent injury, pull the tool slowly and carefully toward you.

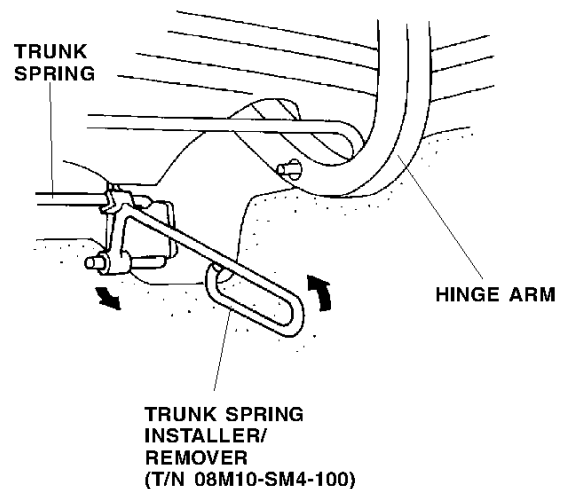

15. Install the heavy-duty springs in the reverse order of removal:

- Set the tool on the unmarked end of each trunk spring.
- While wearing heavy gloves, rotate the tool as you pull it toward you.
- Set the trunk springs in the original notch of the hinge arms.

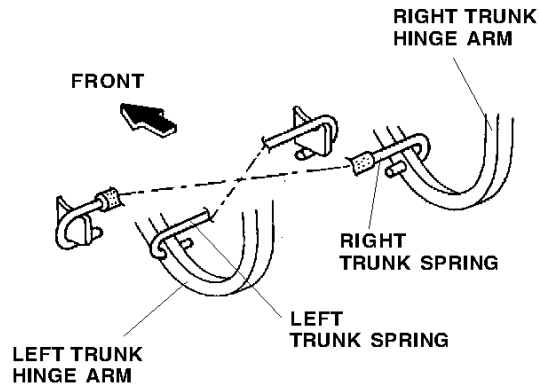

Use and Care of the Spoiler

- Handle the spoiler with care. It is not designed to absorb impact.
- Check the spoiler mounting nuts and bolts periodically, and retighten them if necessary.