



INSTALLATION INSTRUCTIONS

Accessory OUTSIDE TEMPERATURE GAUGE P/N 08E71-SDA-100A	Application ACCORD 2- AND 4- DOOR	Publications No. All 30208
		Issue Date AUG 2005

NOTE: The outside temperature gauge can't be installed if the vehicle is equipped with optional fog lights.

PARTS LIST

Control unit

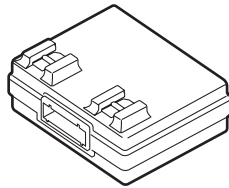

Unit bracket

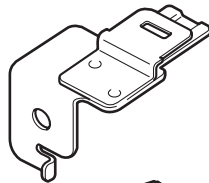

Unit harness

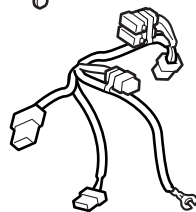

Sensor harness

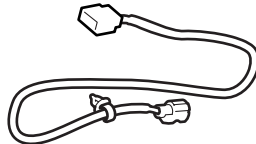

Sensor assembly

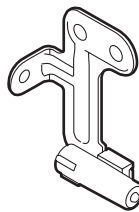

17 Wire ties

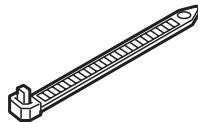

2 Clips



Fuse label (small)

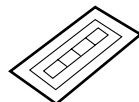

Fuse (3A)

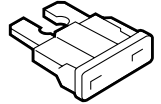

Fuse label (big)

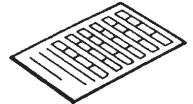

Owner's manual

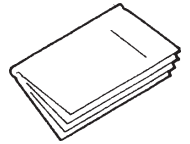

TOOL AND SUPPLIES REQUIRED

- #2 Phillips screwdriver
- Small flat-tip screwdriver
- Felt-tip pen
- 10 mm Combination wrench
- 10 mm Socket
- Ratchet
- Diagonal cutters

Illustration of the Outside Temperature Gauge Installed on the Car

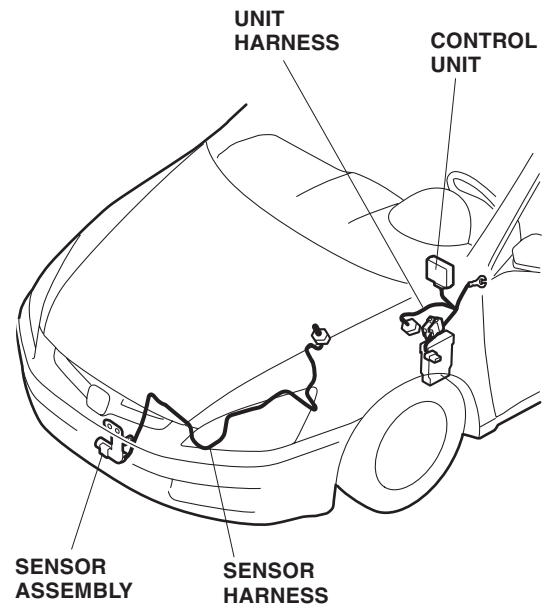

INSTALLATION

Customer Information: The information in this installation instruction is intended for use only by skilled technicians who have the proper tools, equipment, and training to correctly and safely add equipment to your vehicle. These procedures should not be attempted by “do-it-yourselfers.”

1. Make sure you have the anti-theft code for the radio, then write down the frequencies for the preset buttons.
2. Disconnect the negative cable from the battery.

Routing the Sensor Harness

3. Open the hood. Remove the radiator cover (ten clips and four retaining tabs).

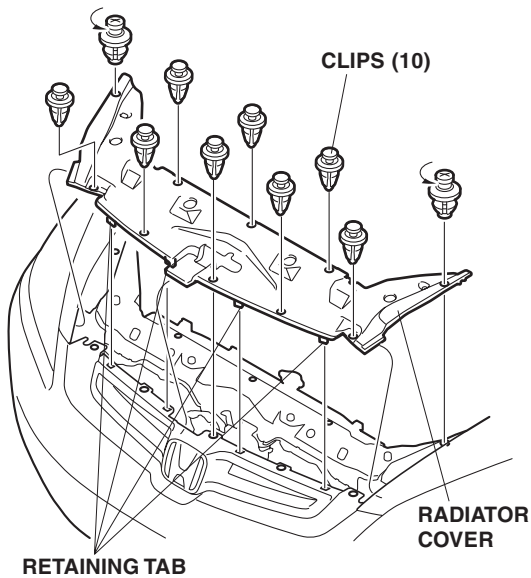

4. Release the three retaining tabs of the hood lock cover, and pull the hood lock cover.

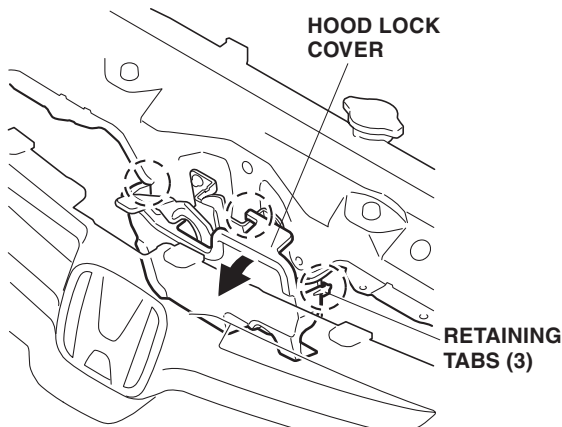

5. Remove the air duct cover (two clips), then remove the air duct.

L4 Engine Model

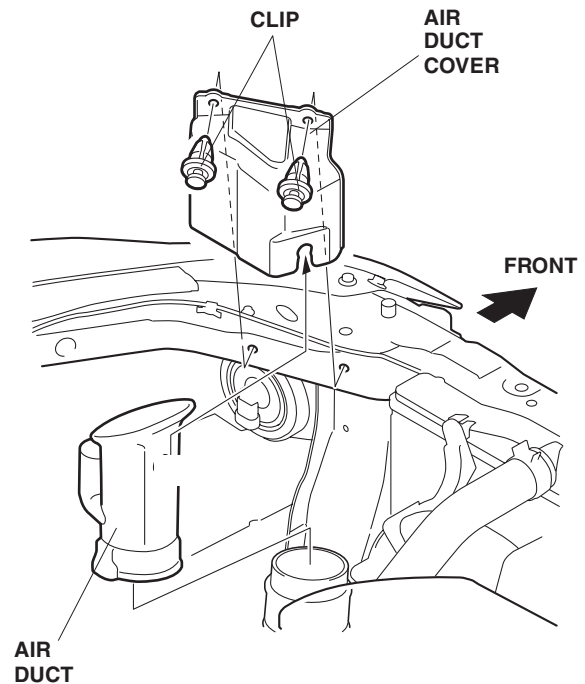

V6 Engine Model

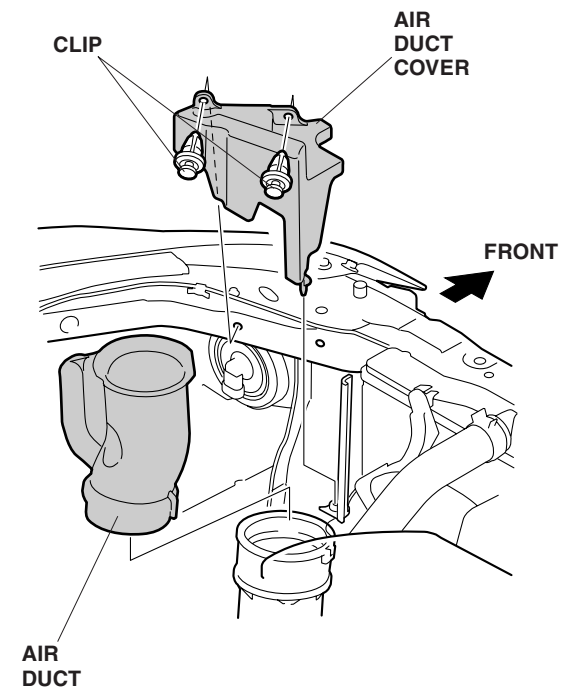

6. Remove the relay box (two bolts), and remove the bolt that fastens the air cleaner housing cover.
7. Install the sensor assembly to the stay on the bumper beam using the two clips and pins.

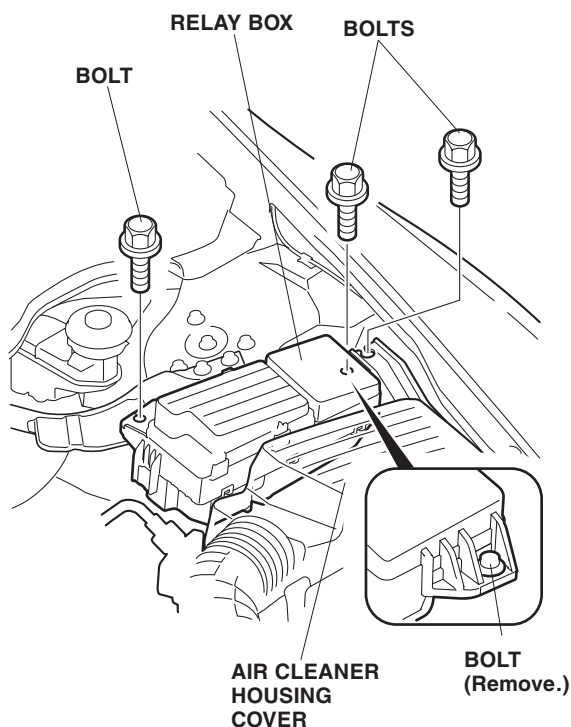

8. Route the sensor harness 2-pin connector through the front bulkhead alongside the vehicle harness.

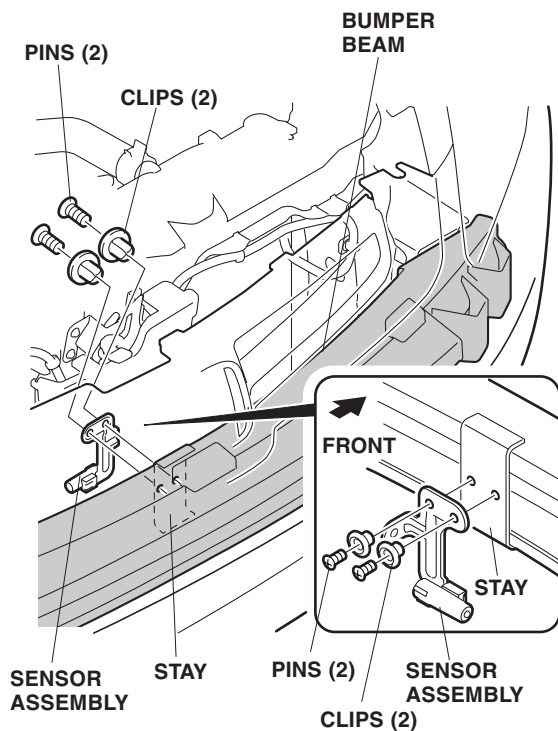

9. Pull hood lock cover, and route the sensor harness 2-pin connector toward the center of the car alongside the vehicle harness. Plug the sensor harness 2-pin connector into the sensor 2-pin connector.

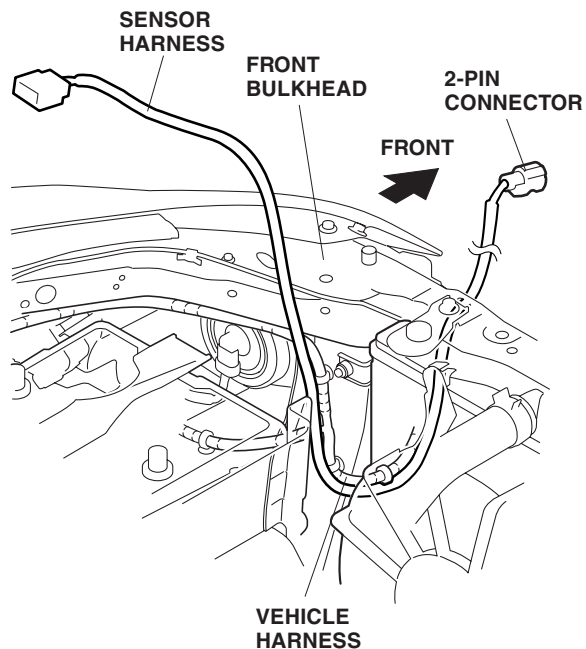

10. Push the sensor harness clip into the hole on the sensor bracket.

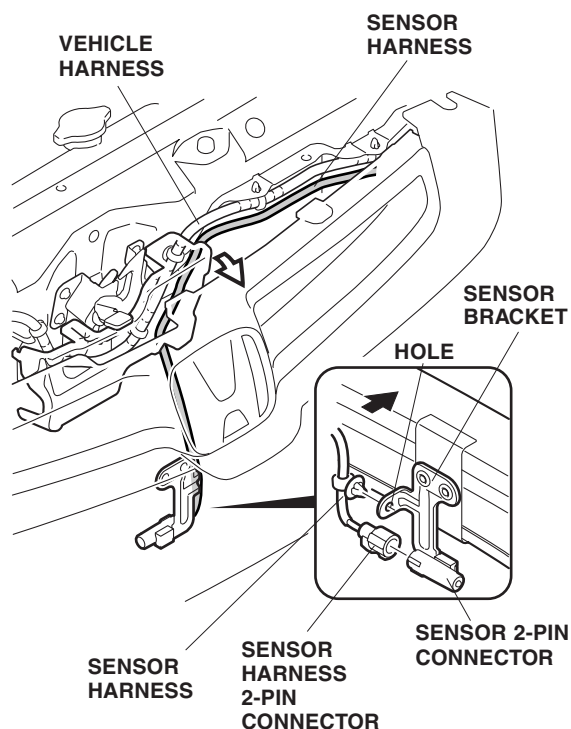

- Pull hood lock cover, and secure the sensor harness to the vehicle harness with the five wire ties in the areas shown.

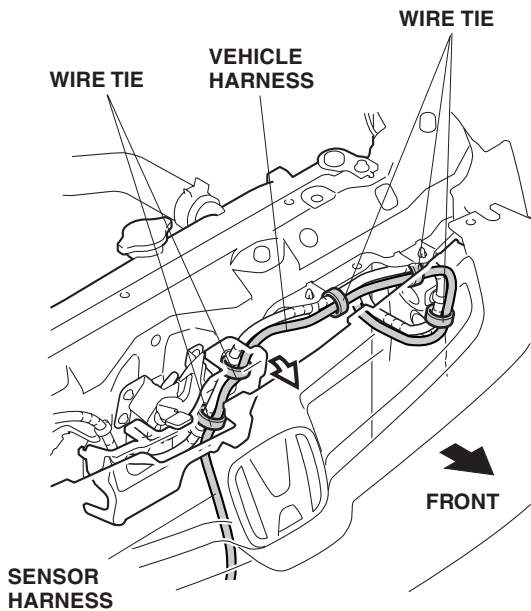

- Near the battery, continue routing the sensor harness along the vehicle harness, and secure it to the vehicle harness with four wire ties.

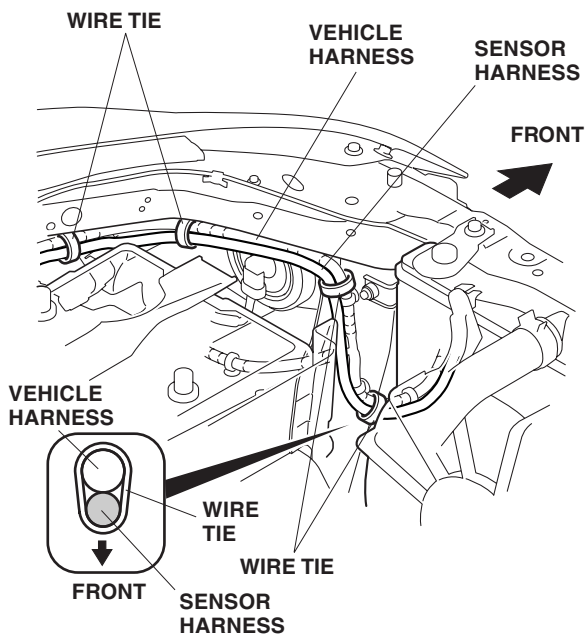

- Lift the air cleaner housing cover upward, and route the sensor harness toward the rear along the vehicle harness.

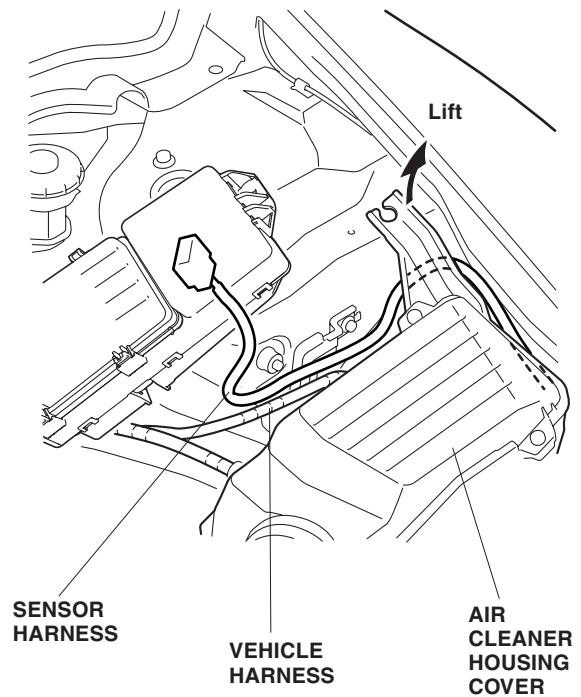

- Under the relay box, locate the vehicle 3-pin connector blue-taped to the vehicle harness, and remove the blue tape to free the connector. Connect the sensor harness 3-pin connector into the 3-pin connector you just freed. Secure the sensor harness to the vehicle harness with wire ties in the areas shown.

A/T Model

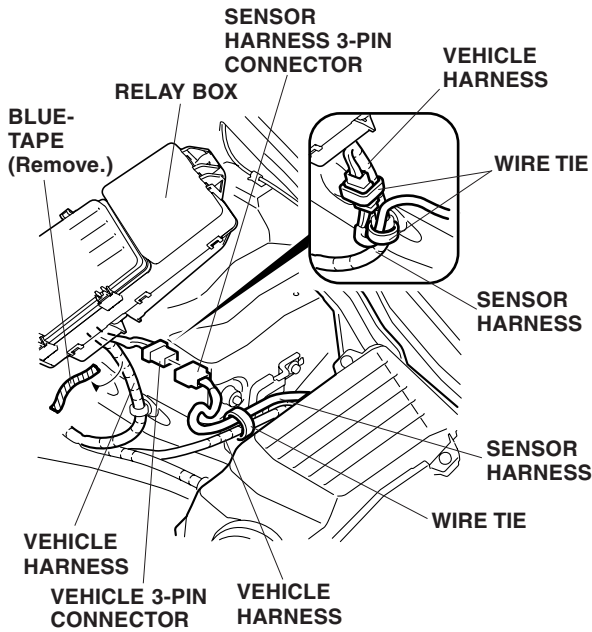

M/T Model

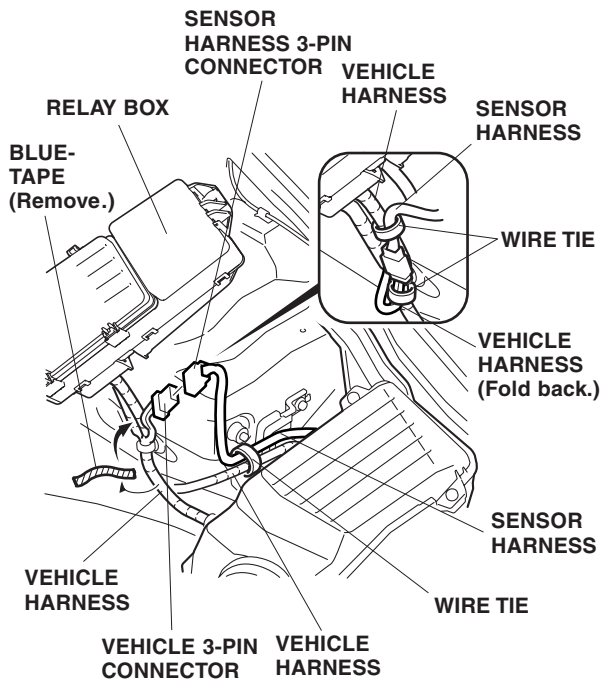

NOTE: If the 3-pin connector is already being used by another accessory, locate the 3-pin connector taped to that other accessory's harness. Remove the tape and dummy connector from that other accessory's harness. Plug the sensor harness 3-pin connector into that other accessory's harness.

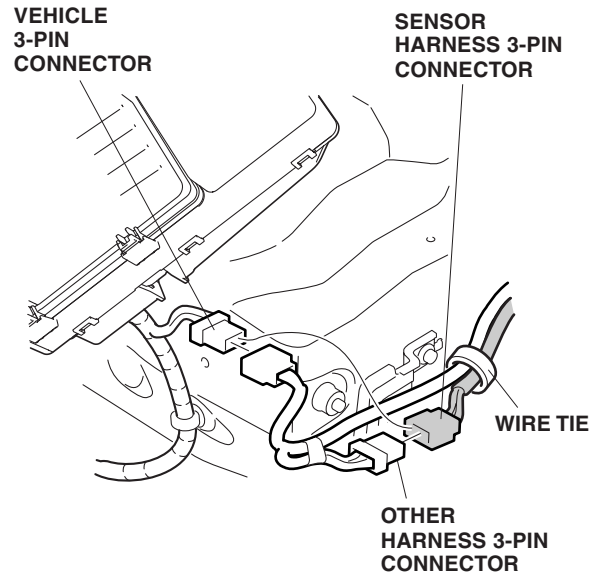

15. Remove the driver's dashboard lower cover:

- Remove the one self-tapping screw.
- Release the four clips on the left side first by pulling out on the driver's dashboard lower cover.
- After releasing the four clips, insert the flat-tip screwdriver between the clip and the dashboard frame. Gently twist the screwdriver to release the clip.
- Release the two clips on the right side finally.
- Unplug the vehicle connector, and remove the lower cover.

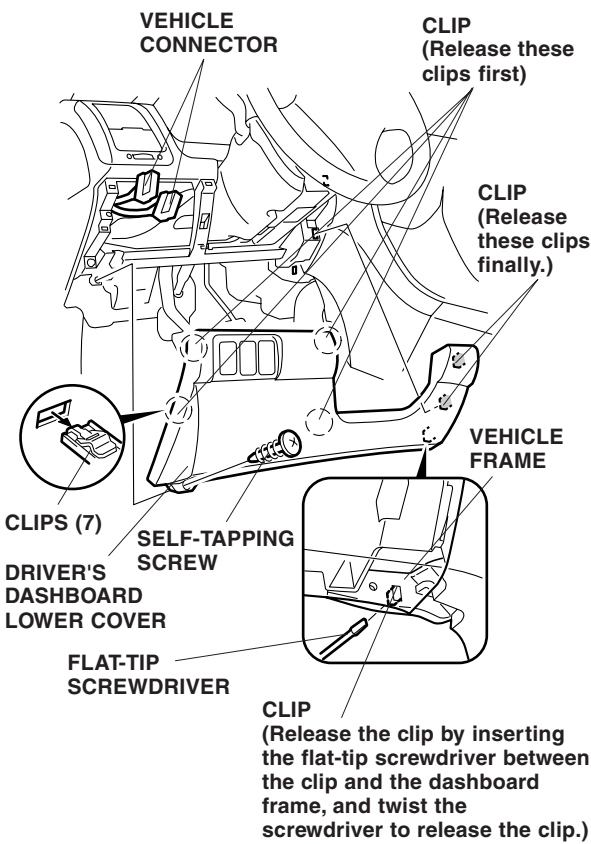

16. Remove the driver's dashboard under cover (release the three retaining clips, one pin and one holder).

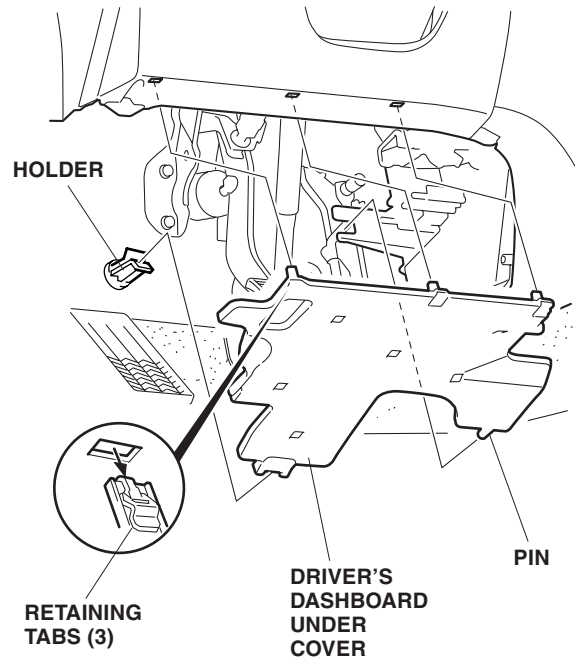

17. Remove the fuse box cover, and install the fuse (3A) provided into the No. 33 slot of the fuse box.

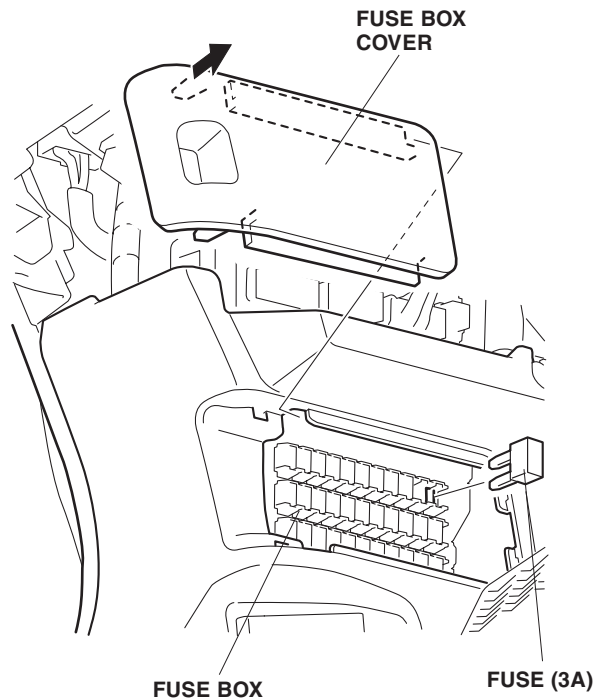

18. Attach the fuse label (3A) over the No. 33 on the back of the fuse box cover.

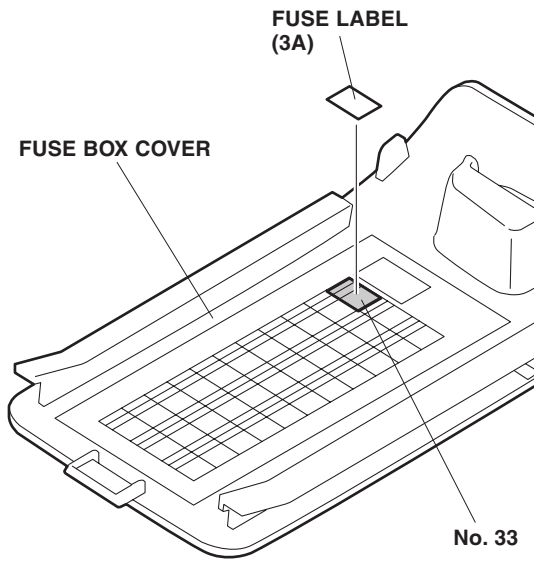

19. Attach the two fuse label (2A) to the fuse cases on the unit harness.

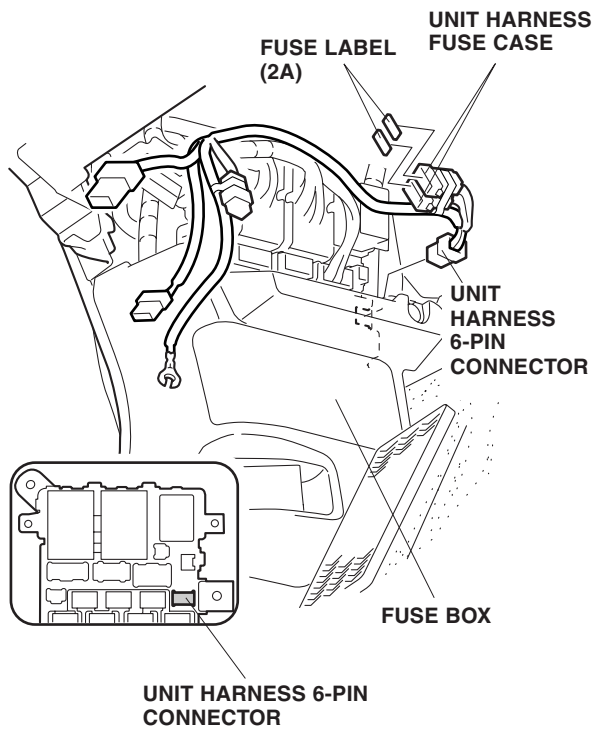

20. Plug the 6-pin connector of the unit harness into the fuse box.

NOTE: If the 6-pin connector is already being used by another accessory, locate the 6-pin connector taped to that other accessory's harness. Remove the tape and dummy connector from that other accessory's harness. Plug the unit harness 6-pin connector into the other accessory's harness.

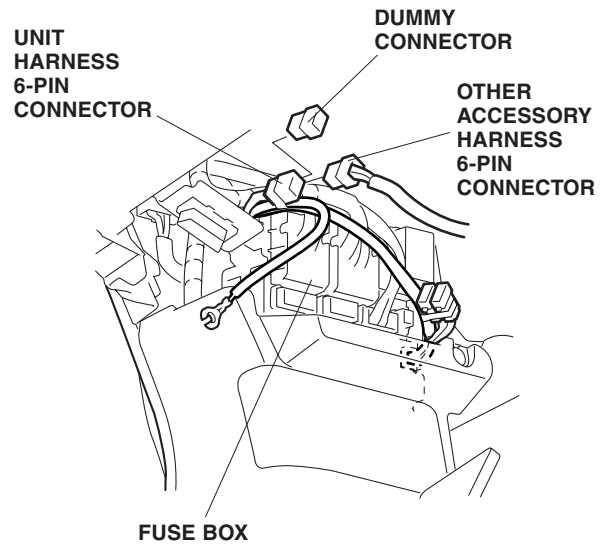

21. Loosen the vehicle ground bolt, and install the unit harness ground terminal with this bolt.

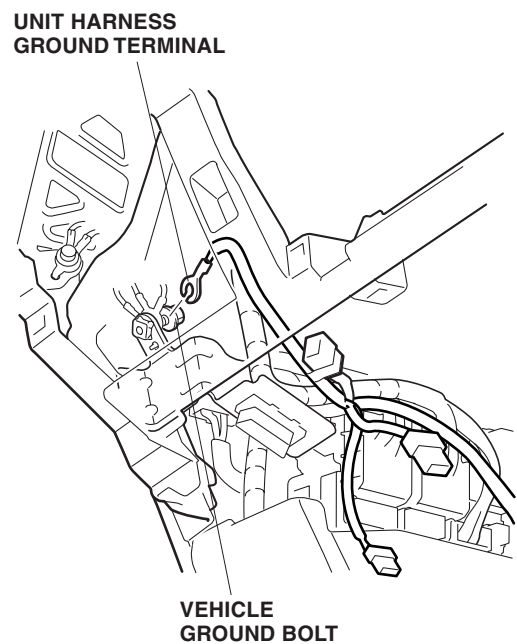

22. Plug the unit harness 22-pin connector into the control unit.

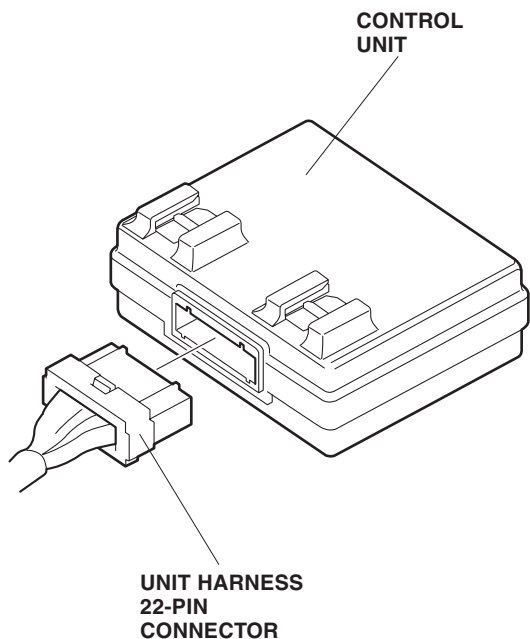

23. On the left side of the steering hanger pipe, Remove the vehicle bracket (one bolt).

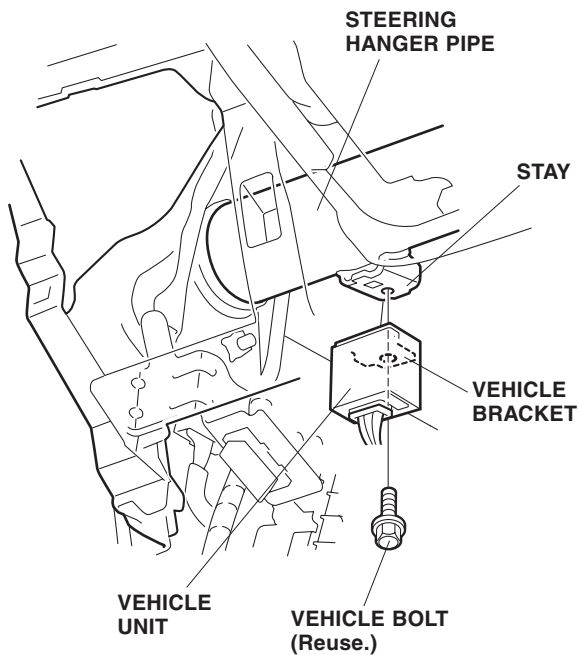

24. Combine the vehicle bracket and the unit bracket, install them to the stay on the steering hanger pipe with the vehicle bolt (reused), and slide the unit bracket onto the control unit.

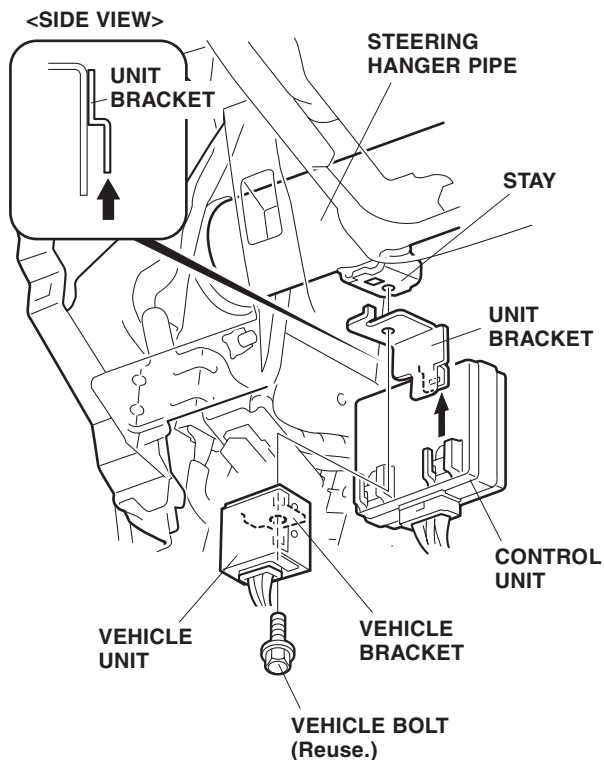

25. On the left side of the steering shaft, locate the 3-pin connector black-taped to the vehicle harness, and connect the unit harness 3-pin connector into that 3-pin connector.

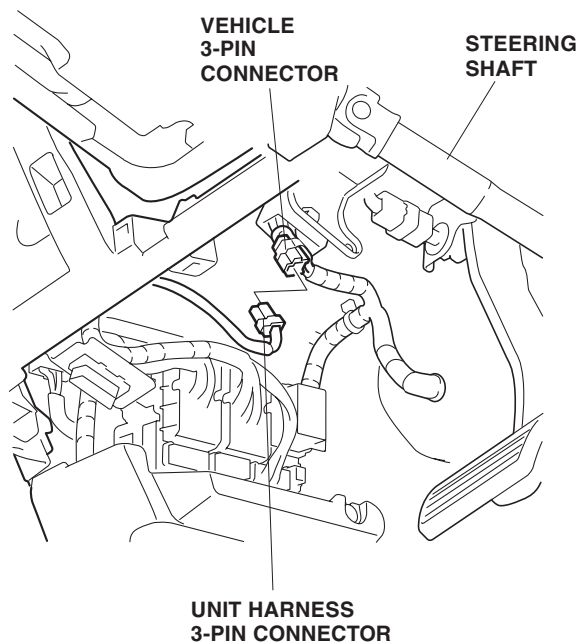

NOTE: If the 3-pin connector is already being used by another accessory, locate the 3-pin connector taped to that other accessory's harness. Remove the dummy connector from that other accessory's harness. Plug the unit harness 3-pin connector into the other accessory's harness.

26. Secure the unit harness to the vehicle harness

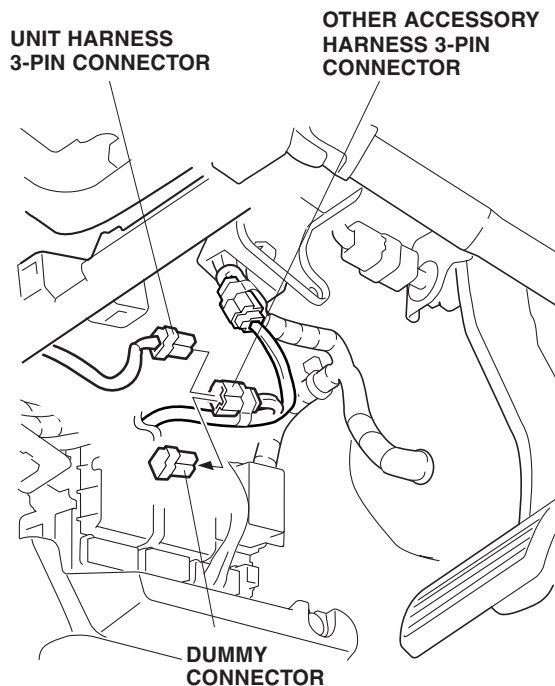

with the five wire ties in the areas shown.

27. Check that all wire harnesses are routed properly

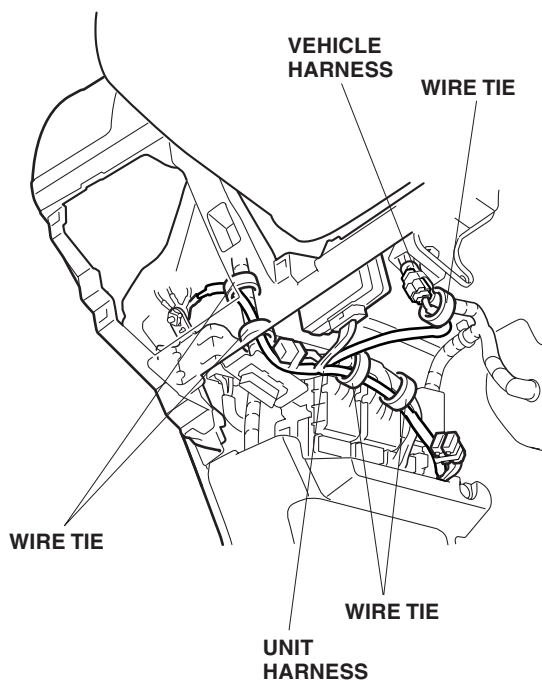

and all connectors are plugged in.

28. Reinstall all removed parts. Check that all clips and fasteners are installed securely.
29. Reconnect the negative cable to the battery.
30. Enter the customer's radio anti-theft code, and reset the radio station presets.
31. Reset the clock.
32. Check operation of out side temperature gauge according to the out side temperature gauge Owner's Manual.

NOTE: Whenever the battery is disconnected, the driver's AUTO function is disabled.

33. Start the engine. Push down on the driver's window switch until the window is fully open.
34. Pull up on the driver's window switch to close the window completely, then hold the switch for 2 seconds.
35. Test the AUTO window function.