

PARTS LIST

Cargo net

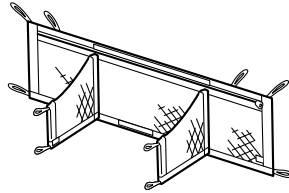

2 Anchors A (Large)



8 Anchors B (Small)



4 Stud bolts



4 Rivet nuts



6 Hex bolts, 6 x 16 mm



2 Flange nuts, 6 mm



8 Plain washers, 6 mm



4 Spring washers, 6 mm



2 Spacers



4-Door Template A (not used)

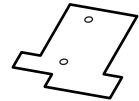

2-Door Template B

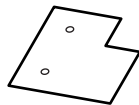

2-Door Template C

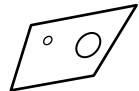

Accessory User's Information Manual

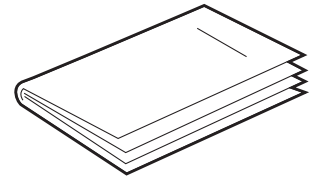

TOOLS AND SUPPLIES REQUIRED

Clip remover

Rivet nut tool (T/N: 07AE-000A100)

Hex wrench

19 mm wrench

Drill

3 mm, 6.5 mm, 8 mm, 9 mm, and 11 mm Drill bits

Eye protection

Pushpin

Round file

Center punch

Masking tape

Tape

Touch-up paint

Torque wrench

INSTALLATION

Customer Information: The information in this installation instruction is intended for use only by skilled technicians who have the proper tools, equipment, and training to correctly and safely add equipment to your vehicle. These procedures should not be attempted by “do-it-yourselfers.”

1. Remove the trunk floor mat (one clip).

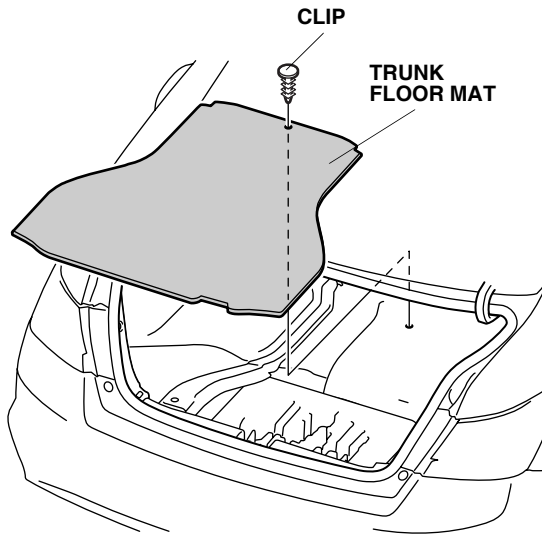

2. Remove the rear trim panel (four clips and three hooks).

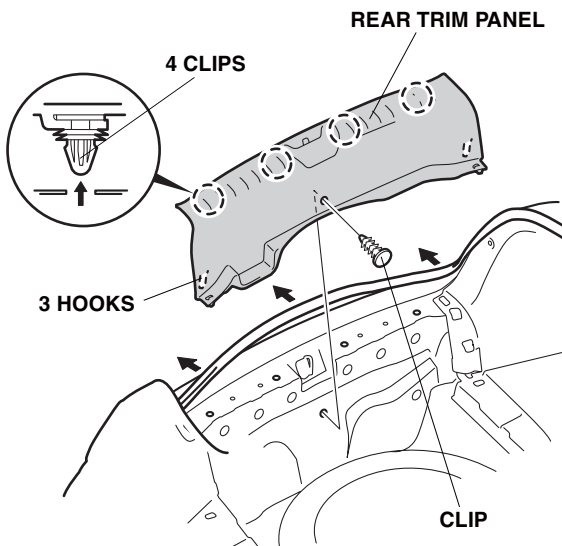

3. Remove the left side trunk trim panel (five clips).

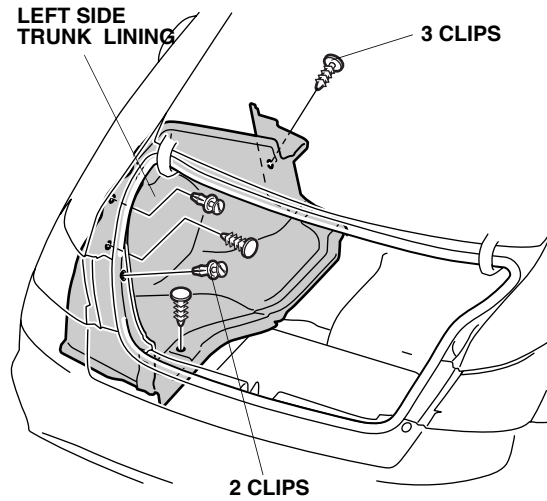

4. Remove the right side trunk lining the same way.

Installing the Anchors

- Wearing eye protection, use a drill to enlarge the two clip holes to 9 mm.
 - Wrap tape around the drill bit at 15 to 20 mm from the tip of the bit.
 - Remove any burrs from the edge of the holes using a round file.
 - Apply touch-up paint to the drilled surface, and allow the paint to dry thoroughly.
 - Repeat the above steps to drill the right side of the vehicle.

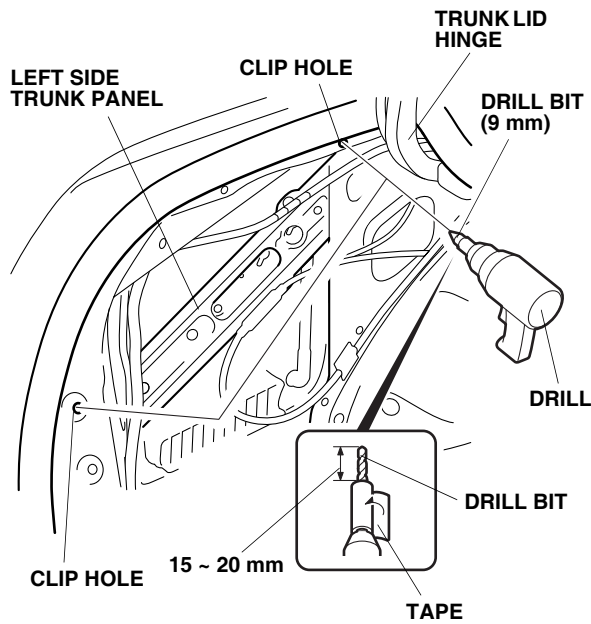

- Install one rivet nut into each enlarged hole:
 - Thread the rivet nut onto the mandrel of the rivet nut tool as shown.

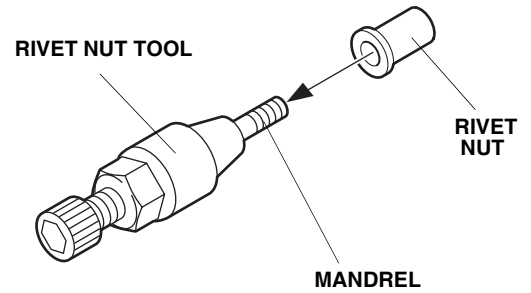

- Insert the rivet nut into the hole in the left trunk side panel, and install the hex wrench.

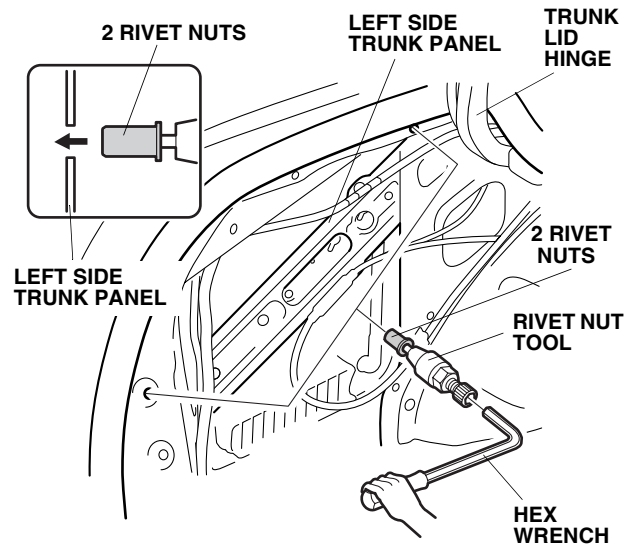

- While holding the rivet nut tool with the hex wrench, use a 19 mm wrench to rotate the tool in a clockwise direction until the rivet nut is fully collapsed.

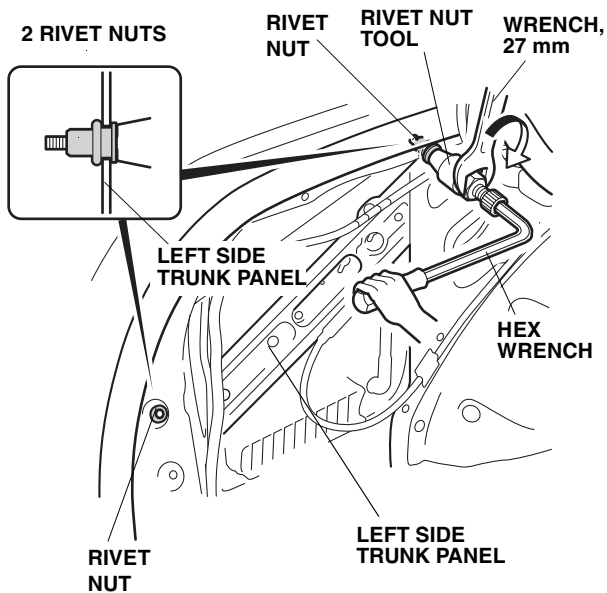

- Remove the rivet nut tool from the rivet nut by turning the hex wrench counterclockwise.
- Repeat these steps to install the rivet nuts in the right side trunk panel.

7. Attach template C to the left side trunk panel using masking tape.
8. Center-punch the side panel at the mark on the template C. Remove the template C.

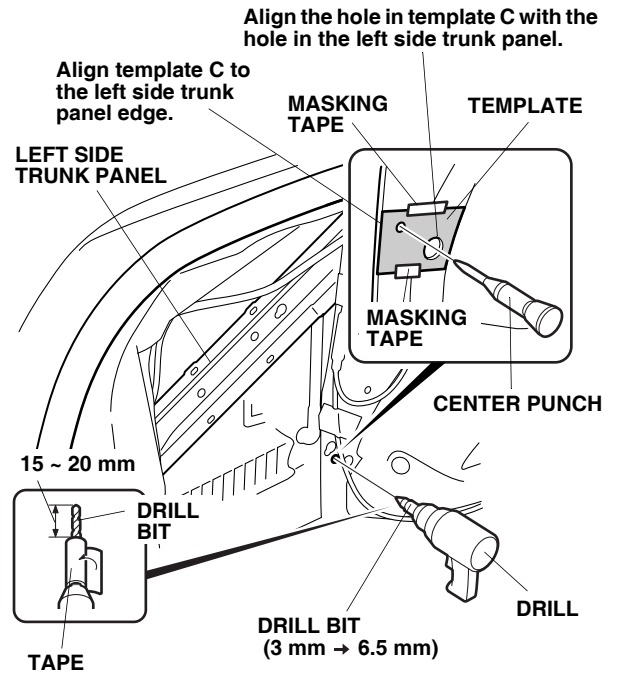

9. While wearing eye protection, drill at the marked point using a 3 mm drill bit, and finish with a 6.5 mm bit.
 - Wrap tape around the drill bit at 15 to 20 mm from the tip of the bit.
 - Remove any burrs from the edge of the holes using a round file.
 - Apply touch-up paint to the drilled surface and allow the paint to dry thoroughly.

- Insert one 6 x 16 mm hex bolt into the hole in the left side panel, and install two 6 mm plain washers and a 6 mm flange nut. Torque the 6 x 16 mm hex bolt to 9.8 N·m (7.2 lb-ft).

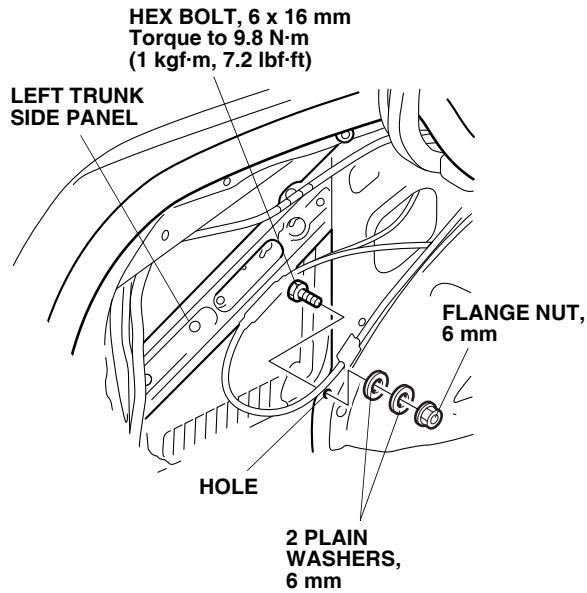

- Turn the template over and repeat steps 7 thru 10 to drill the right side trunk panel.
- Using a pushpin, pierce the center of the circle of dots on the inside of the left side trunk lining.

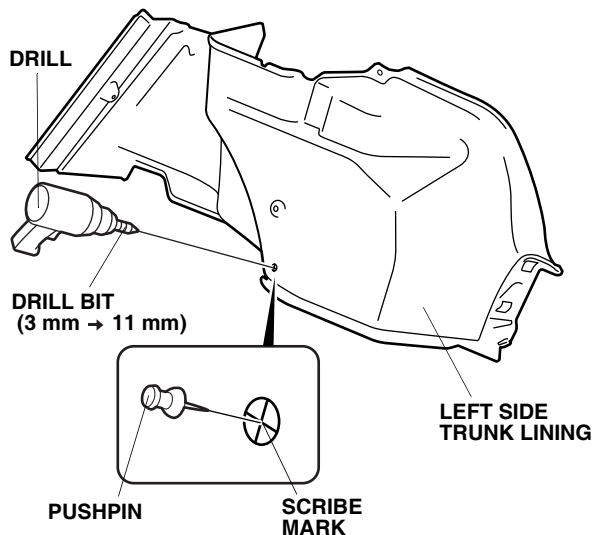

- While wearing eye protection, drill the pierced mark to 11 mm. First drill with a 3 mm bit, and finish with an 11 mm bit.
- Repeat steps 9 and 10 to mark and drill the right side trunk liner.

- Assemble the four small anchors.

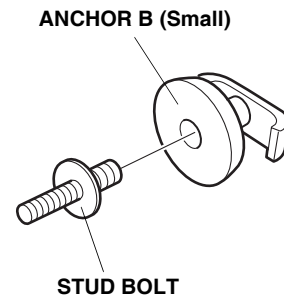

- Install a spacer on two of the assembled anchors. Note the direction of the spacer.

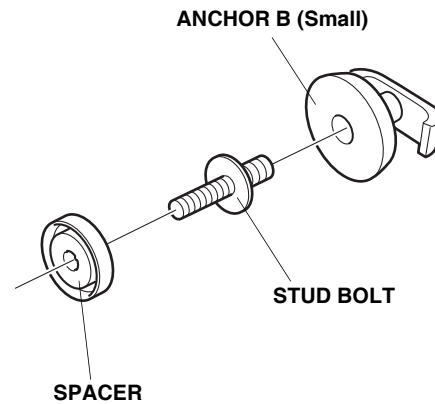

17. Reinstall the left and right side trunk linings (five clips for each panel).
18. Thread one small anchor with spacer into the upper rivet nut, and install one small anchor without spacer into the lower rivet nut. If the anchors are positioned vertically, turn them to the horizontal position.

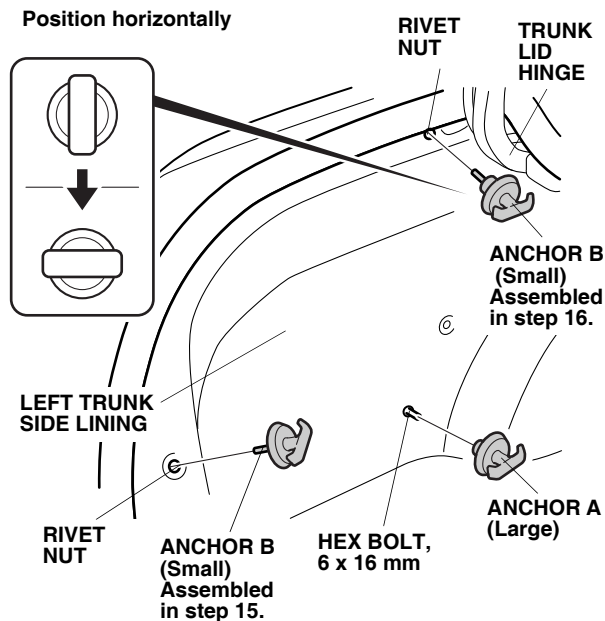

19. Thread one large anchor onto the 6 x 16 mm hex bolt. Position the anchor horizontally. Repeat steps 18 and 19 to install anchors on the right side trunk liner.
20. Attach template A to the back of the trunk rear trim panel using masking tape.

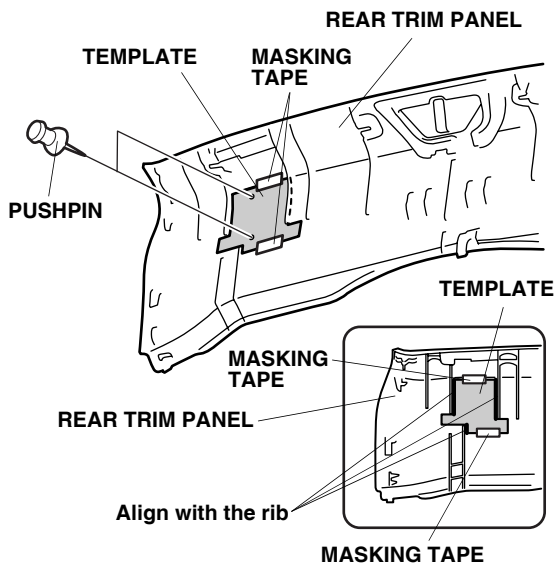

21. Using a pushpin, mark the back of the trunk rear trim panel according to template A. Remove the template.

22. Turn the template over and attach it to the left side of the trunk rear trim panel using masking tape.

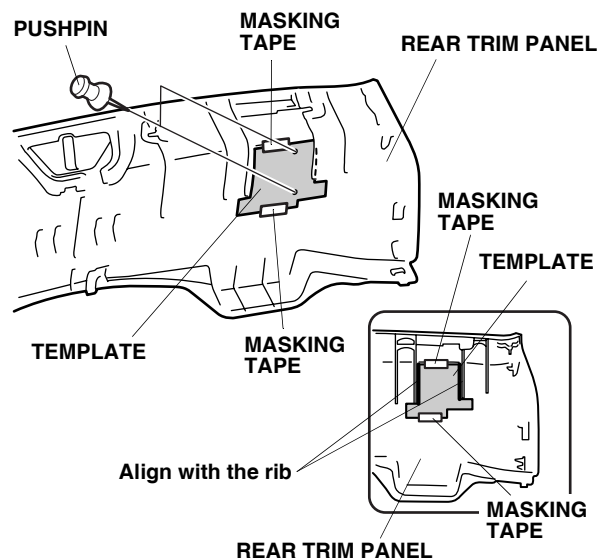

23. Mark the rear trim panel the same way.
24. While wearing eye protection, drill a 6.5 mm hole at each marked position. First drill with a 3 mm bit, and finish with a 6.5 mm bit. Remove any burrs from the edges of the holes using a round file.

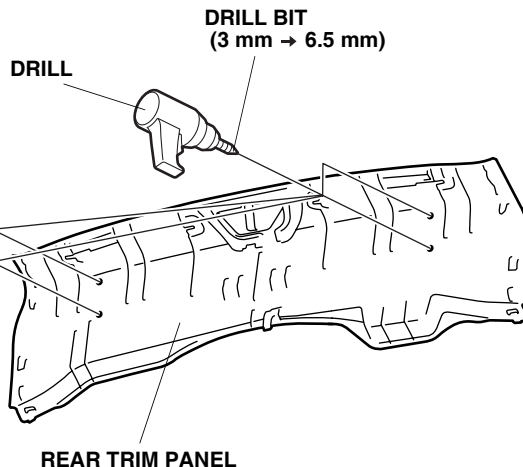

25. Install the four small anchors to the trunk rear trim panel using one 6 x 16 mm hex bolt, one 6 mm spring washer, and one 6 mm plain washer for each anchor. Torque the 6 x 16 mm hex bolts to 5 N·m (3.7 lb·ft). Position each anchor horizontally as shown.

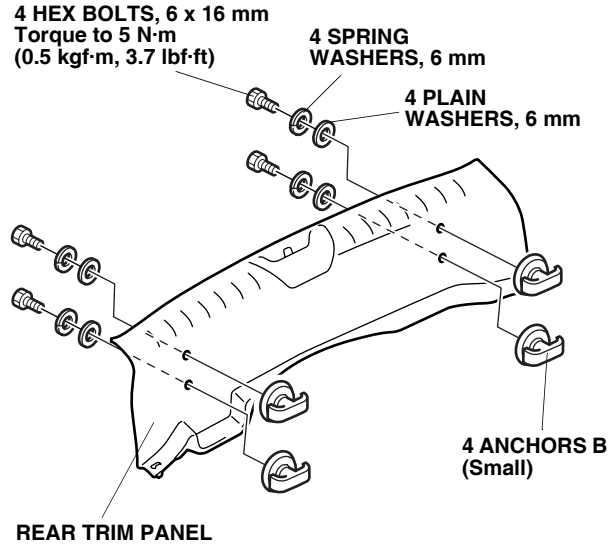

26. Reinstall the rear trim panel (four clips and three hooks).

Installing the Cargo Net

Vertical position: Hook the loops on the cargo net around the anchors.

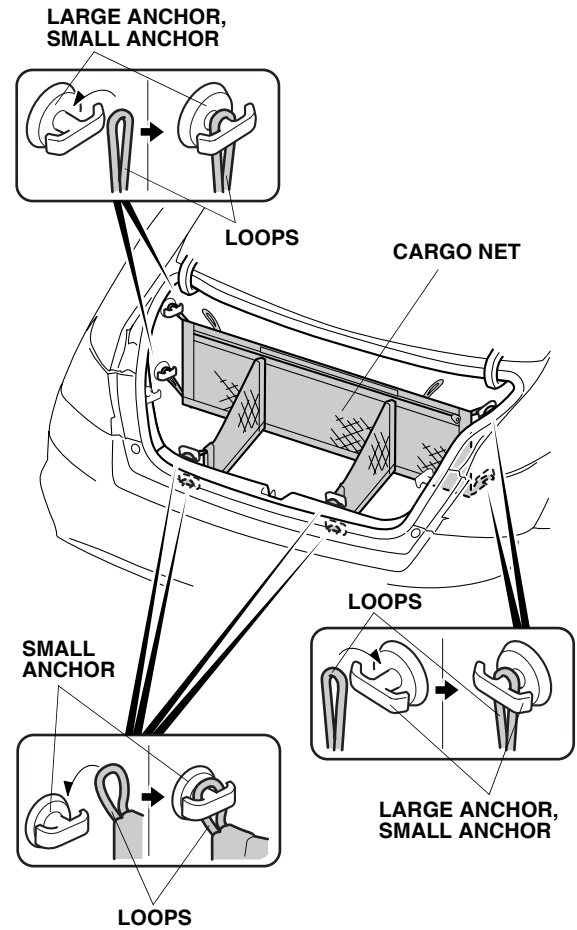

Rear Vertical Position

- Attach the magic-fastener as shown on the cargo net.

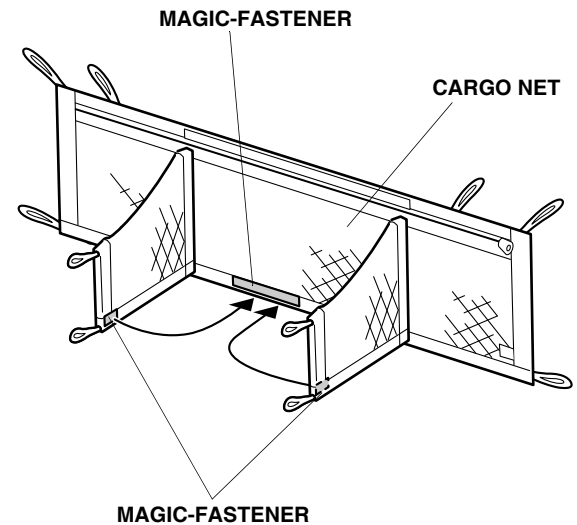

- Hook the loops on the cargo net around the large anchors. Make sure that the reflector tape is visible after installing.

