 HONDA INSTALLATION INSTRUCTIONS	Accessory	Application	Publications No.
	CD CHANGER CONSOLE MOUNT ATTACHMENT KIT	2000 ACCORD 2- AND 4-DOOR (INCLUDES V6)	All 20498 Issue Date JULY 1999

PARTS LIST

CD Changer Attachment Kit:
P/N 08B11-S84-100F

Front bracket

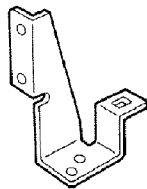

Plate

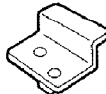

Rear bracket

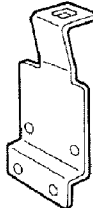

CD changer cover

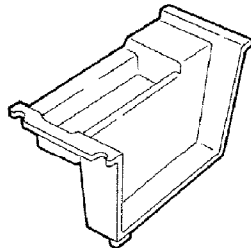

Template A

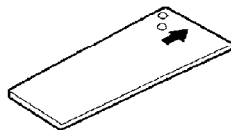

Template B

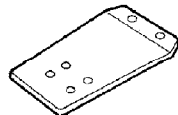

Template C



Bus cable

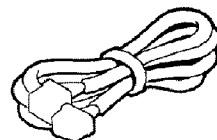

3 Cushion tapes

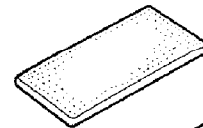

Wire tie

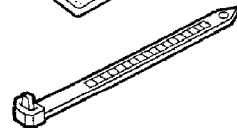

4 Washer-screws,
5 x 12 mm



CD Changer (sold separately):
P/N 08A06-181-420

CD changer

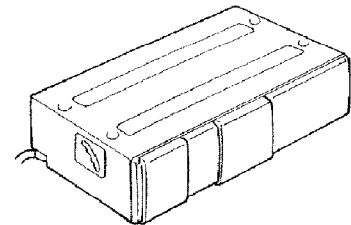

CD magazine

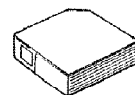

Owner's Manual



4 Hex-head washer-screws,
4 x 6 mm



Adhesive seal sheet

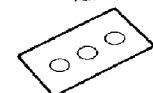

Locking covers

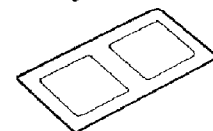

TOOLS AND SUPPLIES REQUIRED

#2 Phillips screwdriver
Flat-tip screwdriver
Stubby Phillips screwdriver
10 mm Combination wrench
Tape measure
Center punch
Drill
6 mm Drill bit
Eye protection (face shield, safety goggles, etc.)
Felt-tip pen
File
Utility knife
20 mm and 35 mm Holesaw
Masking tape
Electrical tape
Diagonal cutters
Awl
Hacksaw blade

Illustration of the CD Changer Installed on the Vehicle

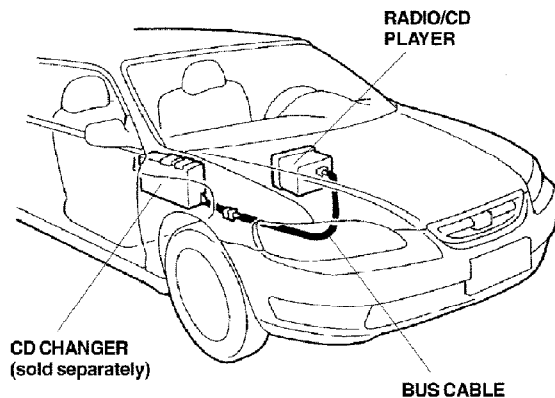

INSTALLATION

Customer Information: The information in this Installation Instruction is intended for use only by skilled technicians who have the proper tools, equipment, and training to correctly and safely add equipment to your car. These procedures should not be attempted by "do-it-yourselfers."

1. Make sure you have the anti-theft code for the radio, then write down the frequencies for the presets buttons.
2. Disconnect the negative cable from the battery.

3. Inside the passenger's compartment, remove the front console lower cover (four retaining clips).

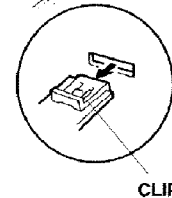
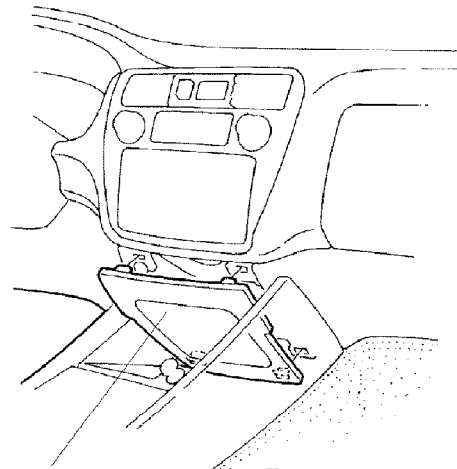

If the vehicle you're working on is equipped with an optional ashtray with cigarette lighter, continue with step 4; if not, go to step 5.

4. Remove the ashtray with cigarette lighter (two self-tapping screws, one connector, and four retaining clips).

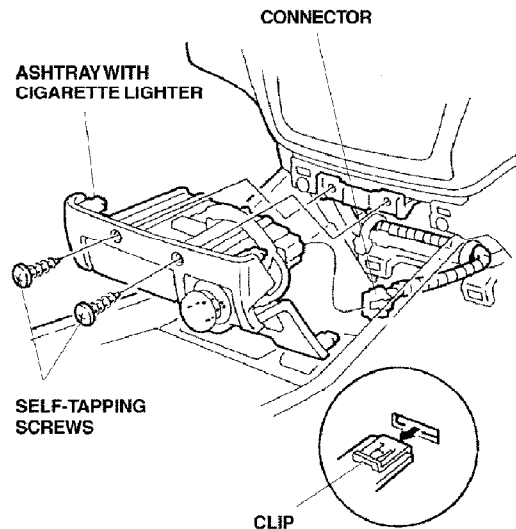

5. On A/T model, pry up on the four retaining tabs, and remove the trim ring. On M/T model, remove the shift knob by turning it counterclockwise.

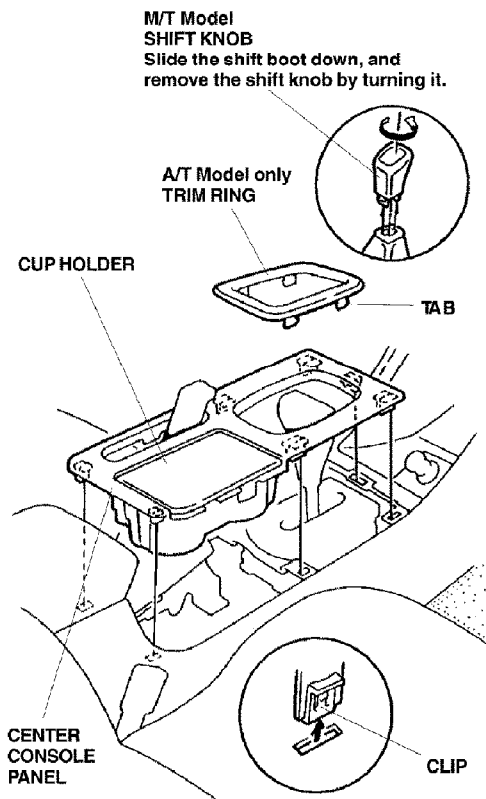

6. Remove the center console panel (seven retaining clips).

7. Attach a piece of masking tape on the console panel below the clock.

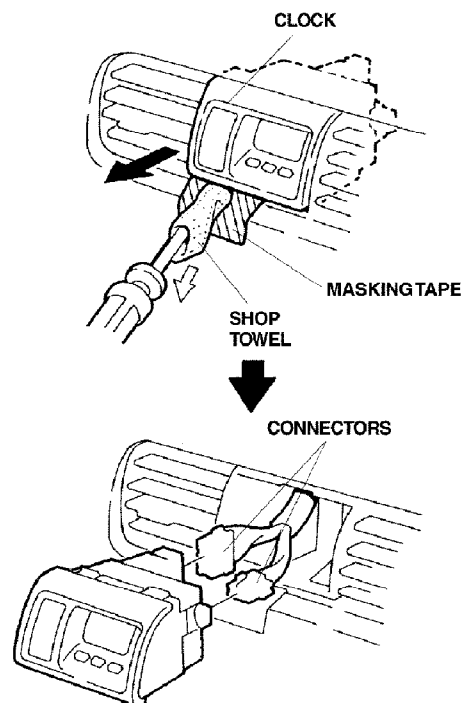

8. Using a flat-tip screwdriver wrapped with a shop towel, gently pry up on the clock to release the clips; then disconnect the connectors and remove the clock.
9. Remove the console panel (three self-tapping screws, five retaining clips, two retaining tabs, and two connectors).

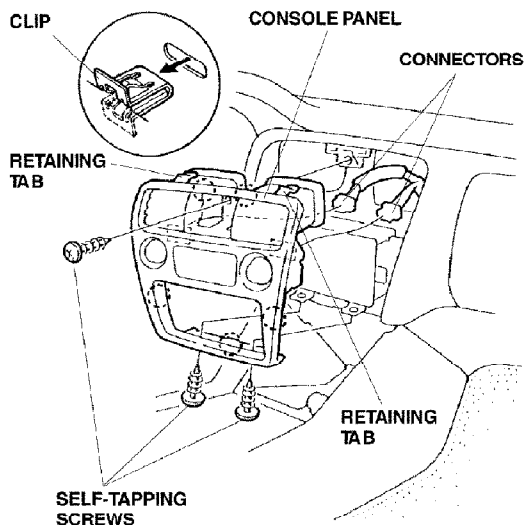

10. Remove the radio (four radio mounting bolts, and unplug the radio connector and the antenna lead).

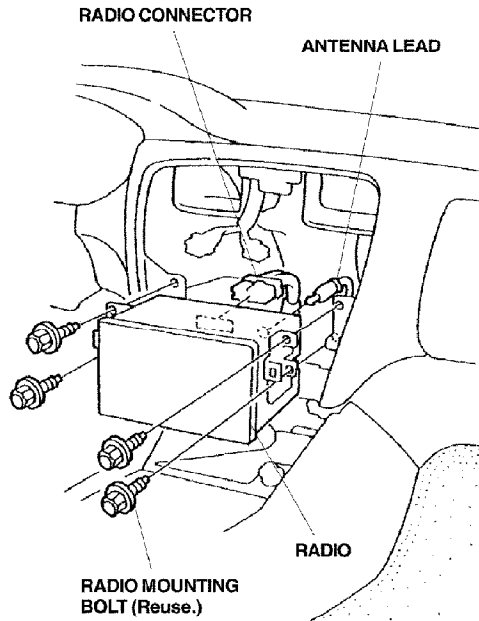

11. Remove the left fuse box cover and the right fuse box cover (three retaining clips and two tabs on each side).

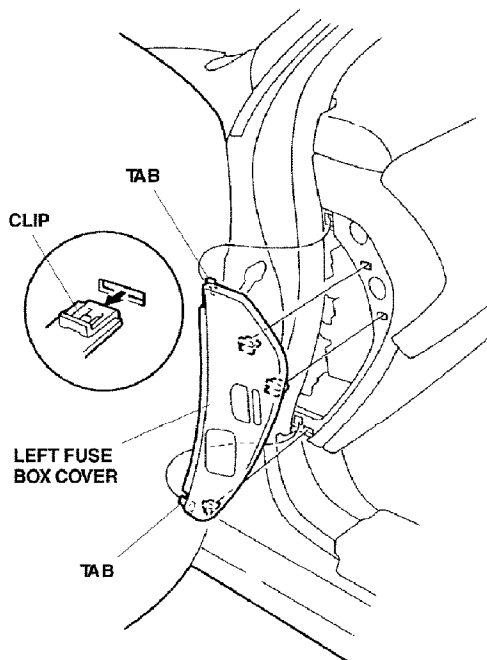

12. Remove the driver's dashboard lower cover (three screws and five retaining clips). Take care not to damage the clips.

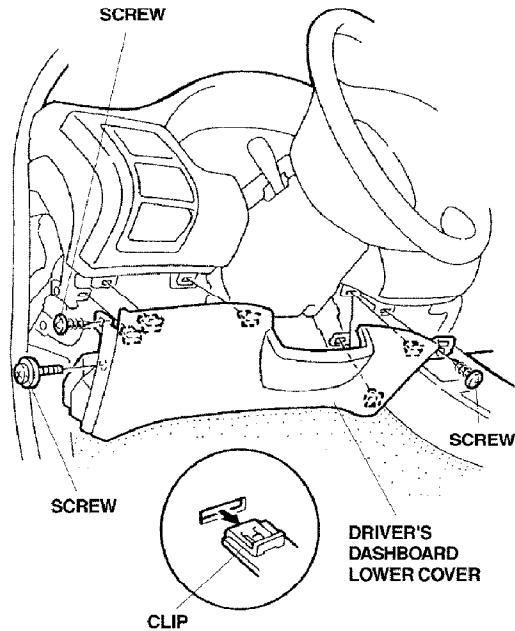

13. Remove the passenger's dashboard lower cover (three screws and seven retaining clips). Take care not to damage the clips.

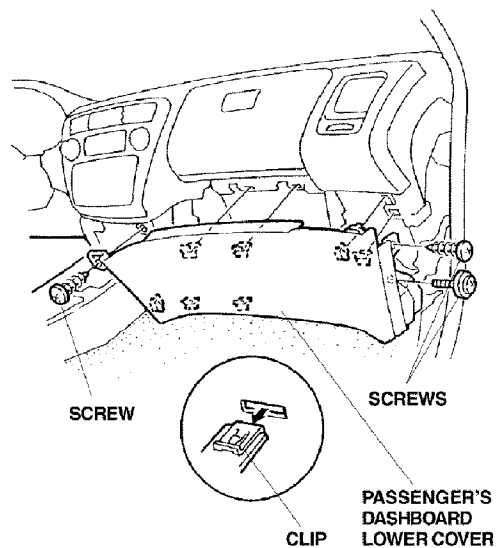

14. Remove the center console:

- Apply masking tape to the front edges of the center console.
- Open the armrest, and remove the plate. Set the plate aside; it will not be reused.
- Remove the eight self-tapping screws.
- Apply the parking brake, and move the shift lever to the N position.
- Unplug the power outlet connector, and release the connector clip; then lift up the center console.

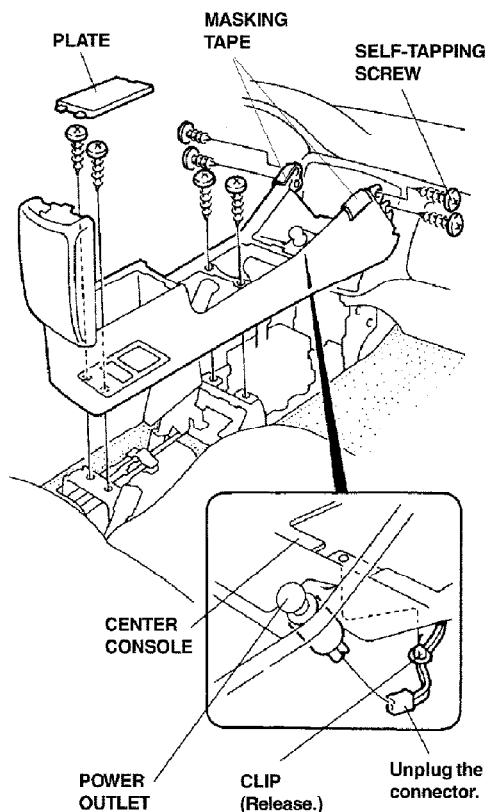

15. Remove the armrest (two screws).

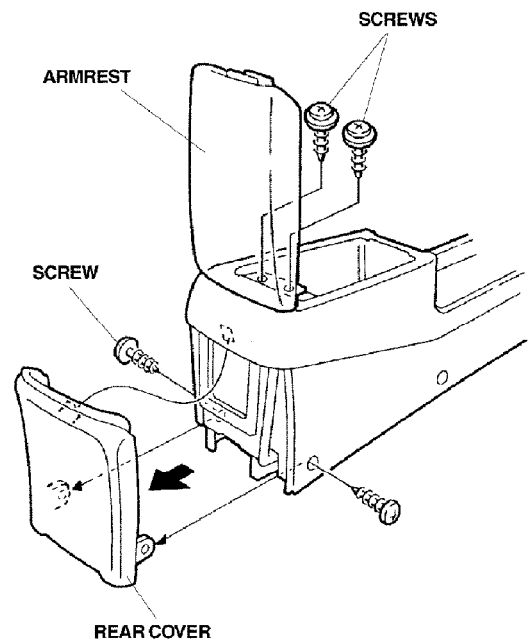

16. Remove the rear cover (two screws).

17. Remove the center console box (four screws, and pull up).

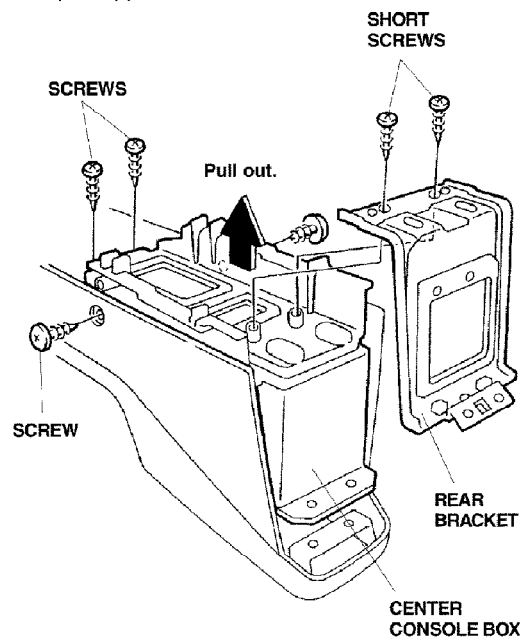

18. Remove the rear bracket (two short screws).

Drilling the Center Console Box

19. Position template A into the center console box with the arrow on the template facing forward. Using a felt-tip pen, mark the center console box through the two holes in the template. Center-punch each mark.

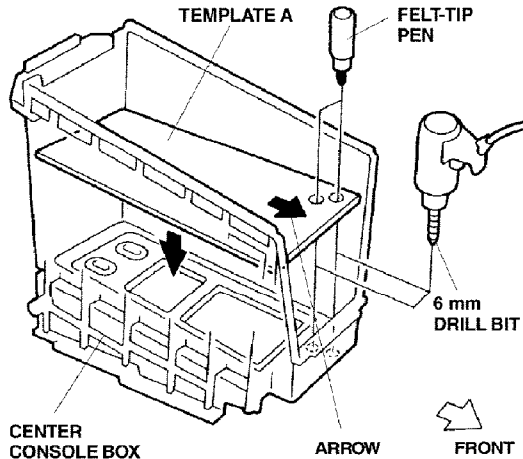

20. While wearing eye protection, drill two 6 mm holes through the marks.
21. Flip over the center console box, and position template C against the front of the center console box. Align the holes in template C with the holes in the center console box.

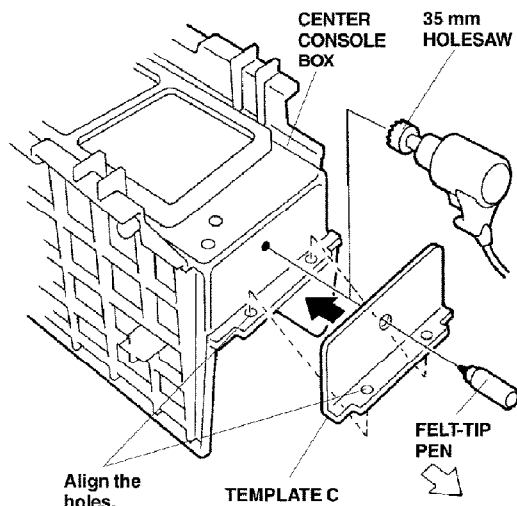

22. Using a felt-tip pen, mark the front of the center console box through the hole in the template. Center-punch the mark.
23. While wearing eye protection, drill a 35 mm hole through the mark using a hole saw.

24. Turn around the center console box, and position template B against the rear of the center console box. Align the holes in the template with the holes in the center console box.

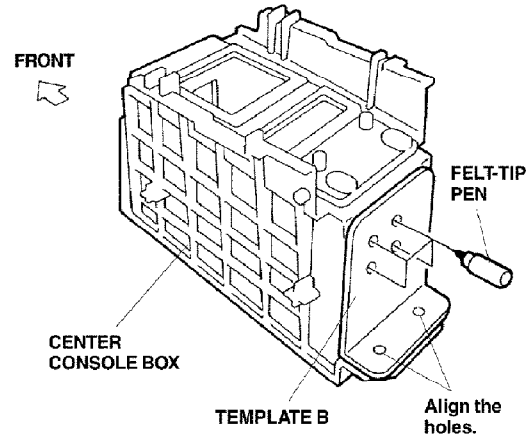

25. Using a felt-tip pen, mark the back of the center console box through the four holes in the template. Center-punch each mark.
26. While wearing eye protection, drill four 20 mm holes through the marks using a hole saw.

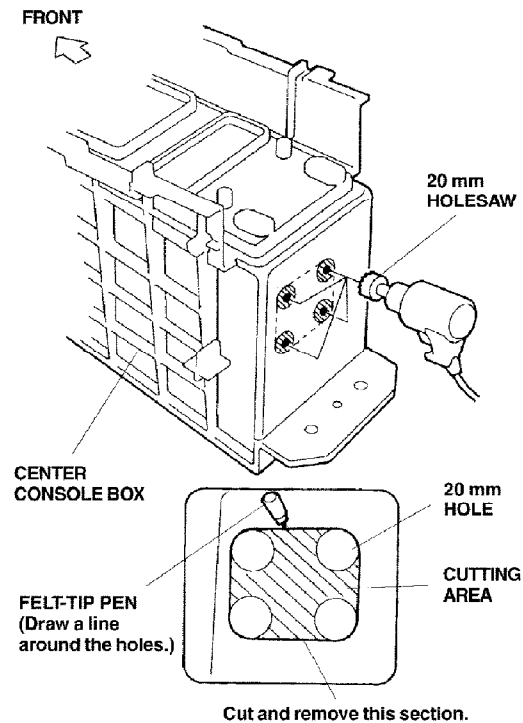

27. Using a felt-tip pen, draw a line around the four holes you drilled. Using a utility knife or a hacksaw blade, carefully cut out the area between the holes.

28. Reinstall the center console box (removed in step 17) to the center console.

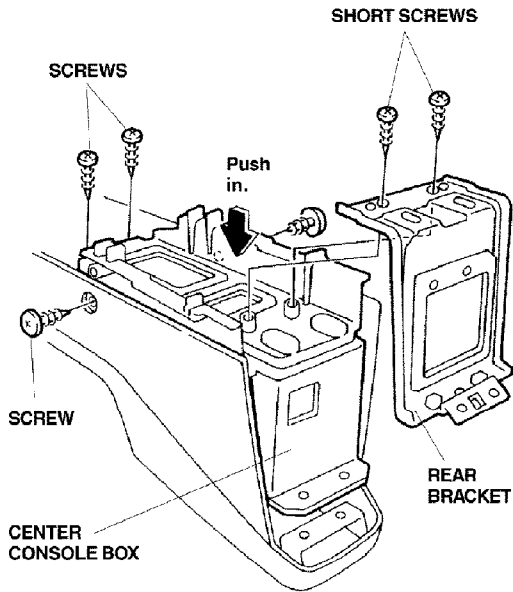

29. Reinstall the rear bracket (removed in step 18) onto the center console.

Routing the Bus Cable

30. Route the bus cable upward, around the right dash support, and out through the radio opening. Pull it out over the radio bracket about 200 mm.

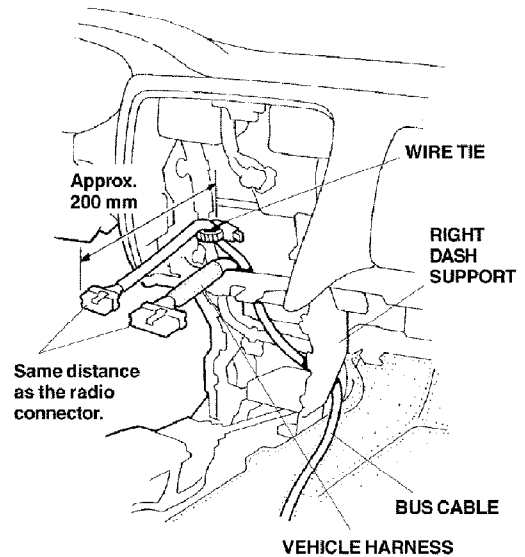

31. Measure about 200 mm of bus cable, and secure the bus cable to the vehicle harness with one wire tie. Cut the excess off the wire tie.
32. Turn over the floor carpet, and route the bus cable toward the rear along the right side of the parking brake lever. Secure the bus cable to the floor with one cushion tape.

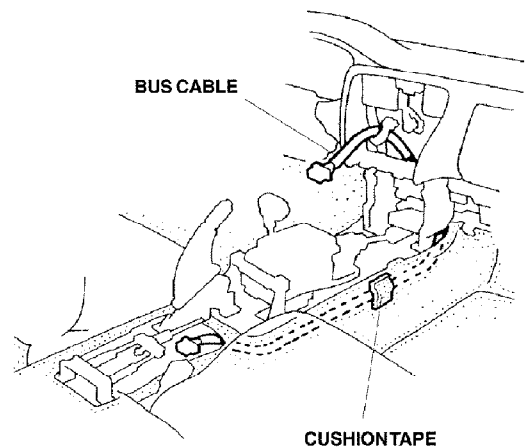

33. Plug in the radio 20-pin connector, the antenna lead, and the bus cable:
- If the vehicle *is not* equipped with an optional cassette player, plug the bus cable into the radio.

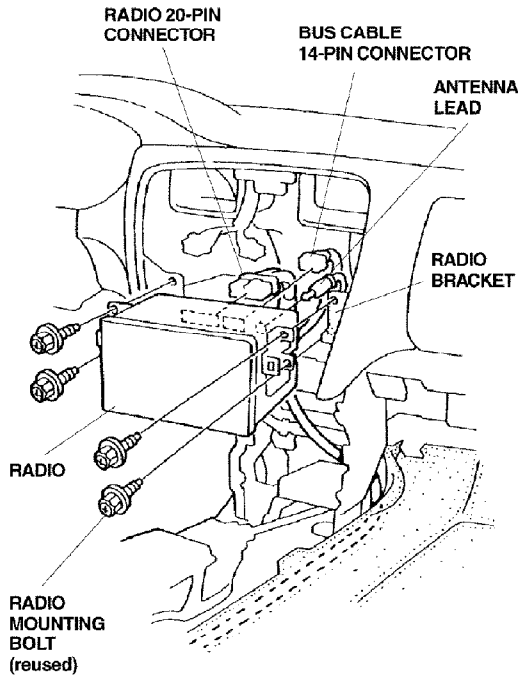

- If the vehicle *is* equipped with an optional cassette player, plug the bus cable into the cassette player.

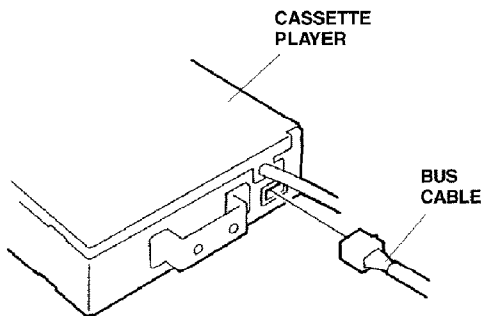

34. Reinstall the radio, and the center console.

35. Carefully unpack the CD changer. Remove the three shipping screws, and discard the shipping cover. Install an adhesive seal (included with the CD changer kit) over each of the three screw holes. Save the shipping screws in the event the unit needs to be serviced.

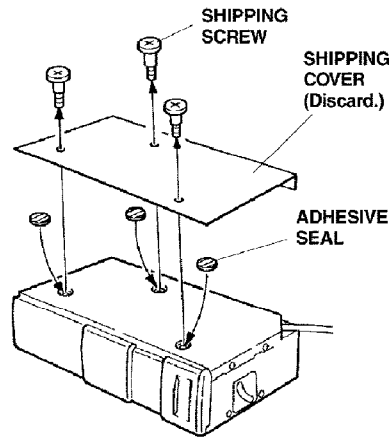

36. Visually check the position of the spring adjusting pin on both sides of the CD changer. If the spring adjusting pins are not in the horizontal (H) position, move the pins to the horizontal (H) position by sliding them up with an awl.

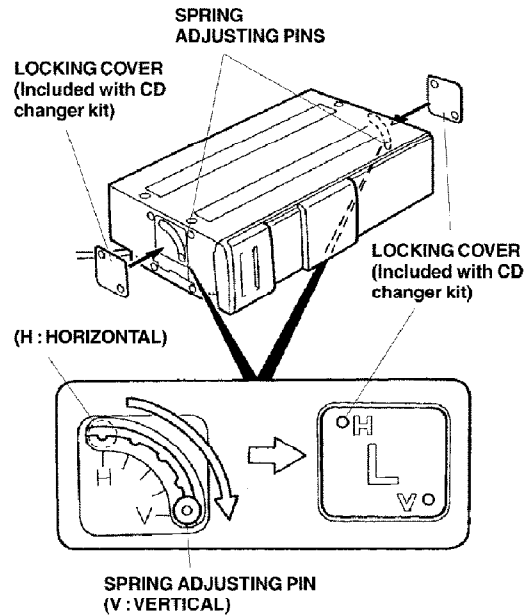

37. Remove the adhesive backing from the "L" and "R" locking covers, and attach them to the sides of the CD changer. Align the diagonally opposite holes with the H and V positions.

38. Install the rear bracket onto the CD changer using two of the 4 x 6 mm hex-head washer-screws supplied with the CD changer.

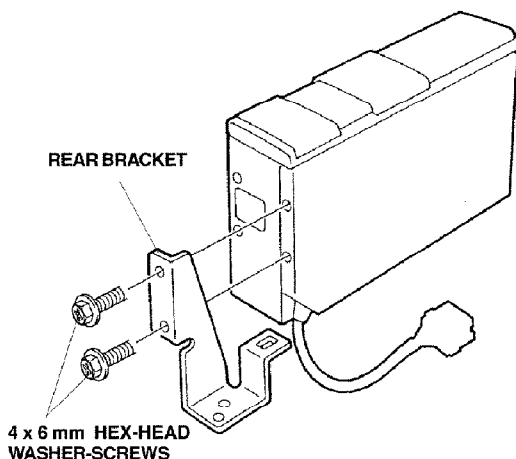

39. Place the plate (from the attachment kit) under the front portion of the center console and into the two holes in the bottom of the box. Route the connector from the CD changer through the hole you drilled in the front of the center console box; then place the CD changer into the center console.

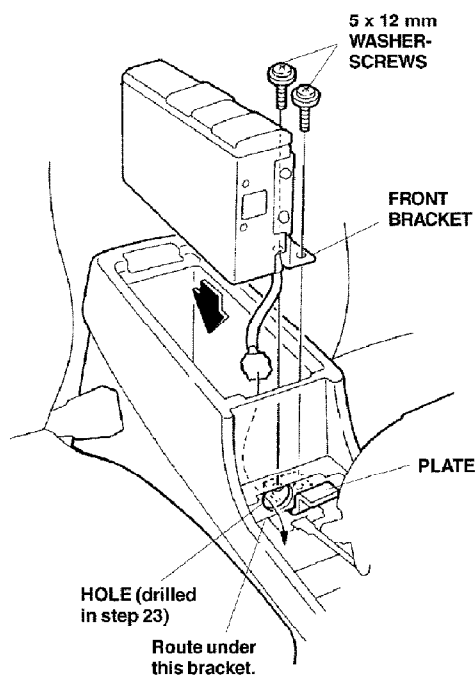

40. Attach the front bracket to the plate with two of the 5 x 12 mm washer-screws supplied with the CD changer attachment kit.

41. Insert the rear bracket between the CD changer and the inside of the center console box, and attach the rear bracket to the center console box with two of the 4 x 6 mm hex-head washer-screws supplied with the CD changer and two of the 5 x 12 mm washer-screws supplied with the CD changer attachment kit.

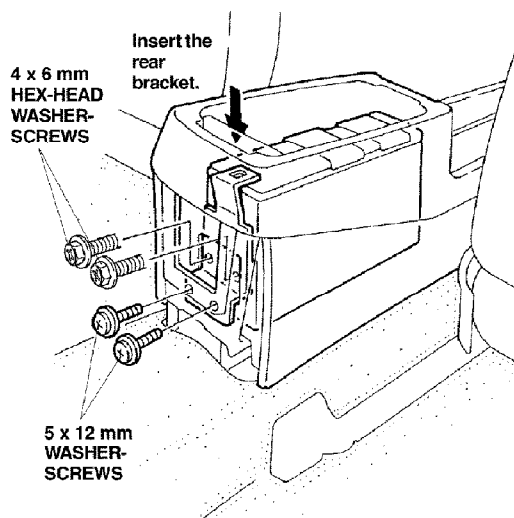

42. Install the CD changer cover over the CD changer, and attach it to the front and rear brackets by inserting the two clips.

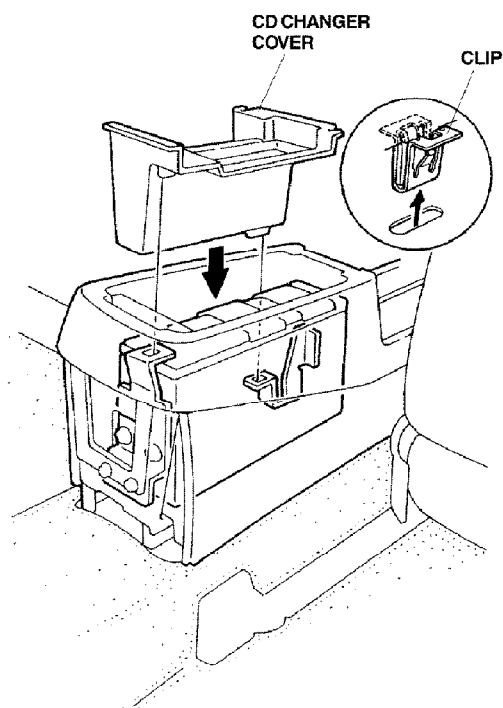

43. Connect the bus cable 14-pin connector to the CD changer 14-pin connector.

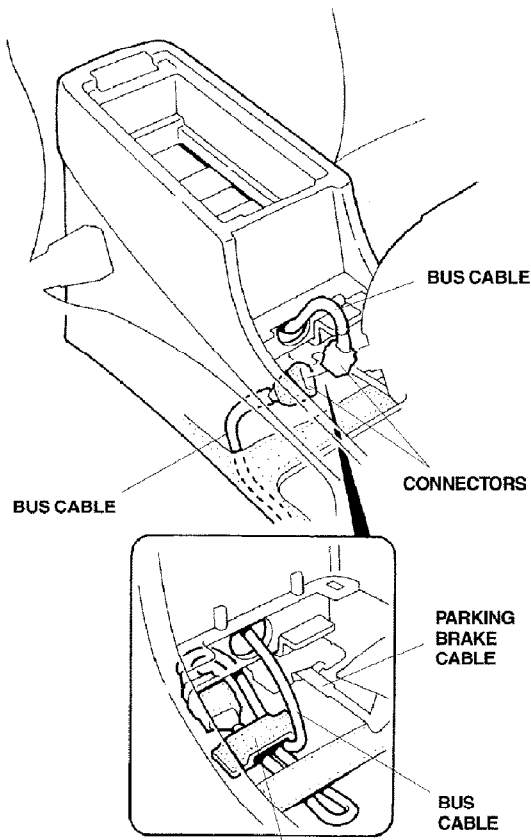

CUSHIONTAPE
Do not interfere with the parking brake cable. Secure the bus cable to the floor panel with cushion tape.

44. Fold the excess length of bus cable, and secure it to the floor panel with one cushion tape. Make sure the bus cable doesn't interfere with the parking brake cable.

45. Reinstall the armrest and the rear cover to the center console.

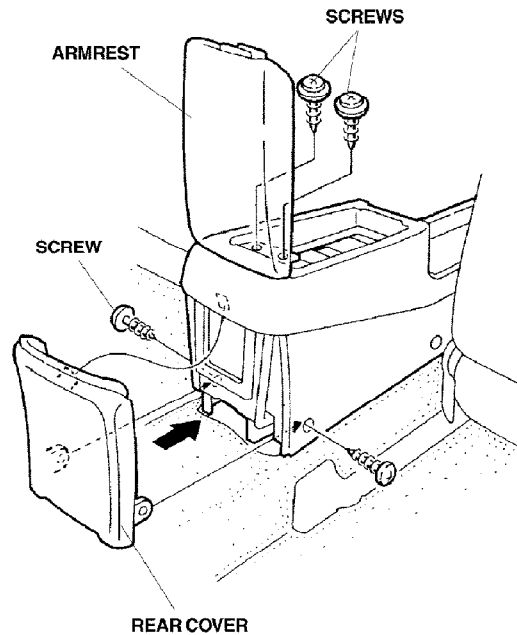

46. Check that all wire harnesses are routed properly and all connectors are plugged in.
47. Check that the radio and the CD changer operate properly as described in the respective owner's manuals.
48. Reinstall all removed parts.
49. Enter the customer's radio anti-theft code, and reset the radio station presets.
50. Reset the clock.
51. Put the CD Changer Owner's Manual and the shipping screws (removed in step 35) in the glove box.