

H HONDA INSTALLATION INSTRUCTIONS	Accessory	Application	Publications No.
	EXHAUST PIPE TRIM P/N 08F53-S84-100 V6: P/N 08F53-S87-100F	2000 ACCORD 2- AND 4-DOOR	All 20505
			Issue Date JULY 1999

PARTS LIST

Exhaust pipe trim

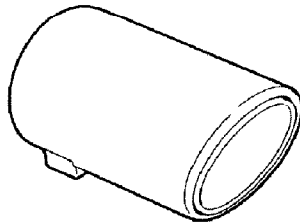

Flange bolt, 6 x 14 mm



TOOLS REQUIRED

10 mm Socket

Torque wrench

INSTALLATION

NOTE:

- Allow the exhaust pipe to cool down before you install the exhaust pipe trim.
- In these instructions the illustrations show a single exhaust pipe trim being installed. The same procedure applies for installing exhaust pipe trim on a dual exhaust system.

1. Partially thread the 6 mm bolt into the exhaust pipe trim.

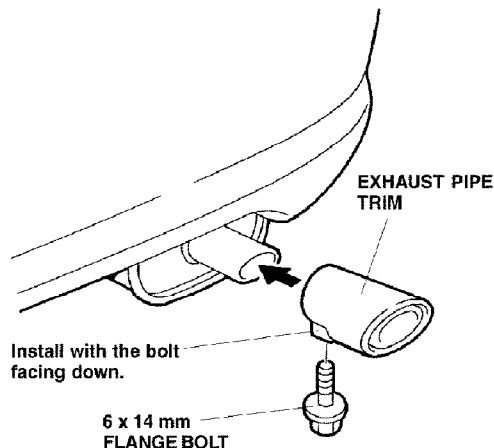

2. With the 6 mm bolt facing down, slide the exhaust pipe trim onto the exhaust pipe until it bottoms against the exhaust pipe.

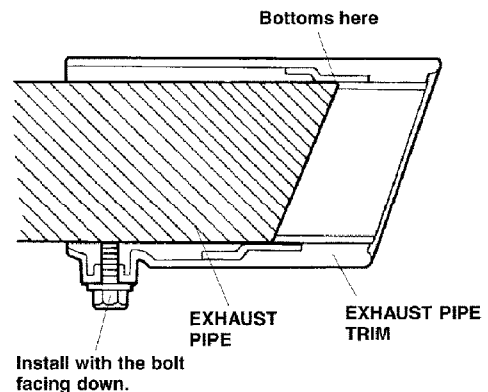

3. While pushing the exhaust pipe trim firmly against the exhaust pipe, torque the 6 mm bolt to 7 to 12 N•m (5 to 8 lb-ft).
4. Start the engine, and rev it up a few times. Listen for any rattling noise coming from the exhaust pipe trim, and adjust as necessary.

