

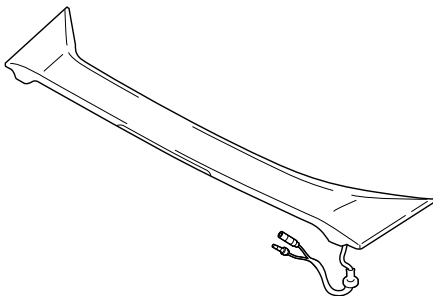



INSTALLATION INSTRUCTIONS

Accessory	Application	Publications No.
REAR WING SPOILER	CIVIC 2-DOOR	All 23144
		Issue Date
		SEP 2001

PARTS LIST

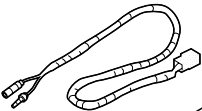
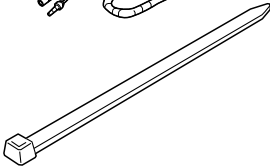
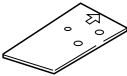
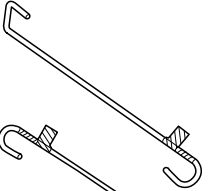
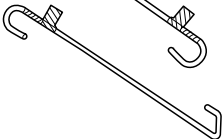
- Rear wing spoiler 
- 4 Cap nuts 
- Spoiler harness 
- 12 Wire ties 
- Template 
- Left trunk spring (marked white or yellow) 
- Right trunk spring (marked blue) 

TOOLS AND SUPPLIES REQUIRED

- Shop towel
- Small flat-tip screwdriver
- Eye protection (face shield, safety goggles, etc.)
- Drill
- 3 mm, 6 mm, and 10 mm Drill bits
- Drill stop
- 10 mm Combination wrench
- Felt-tip pen
- Center-punch
- File
- Touch-up paint
- Hammer
- Piece of wire
- 10 mm Socket
- Torque wrench
- Heavy gloves
- Clip remover
- Trunk Spring Installer/Remover:
T/N 08M10-SM4-100

INSTALLATION

Customer Information: The information in this installation instruction is intended for use only by skilled technicians who have the proper tools, equipment, and training to correctly and safely add equipment to your car. These procedures should not be attempted by "do-it-yourselfers."

Installing the Rear Wing Spoiler

1. Make sure you have the anti-theft code for the radio, then write down the frequencies for the preset buttons.
2. Disconnect the negative cable from the battery.
3. Inside the trunk lid, locate the two identification marks on the trunk lid. If necessary, scrape away the seam sealer so you can see the outline of the marks. Mark and lightly center-punch the center of the marks. Repeat on the other side.

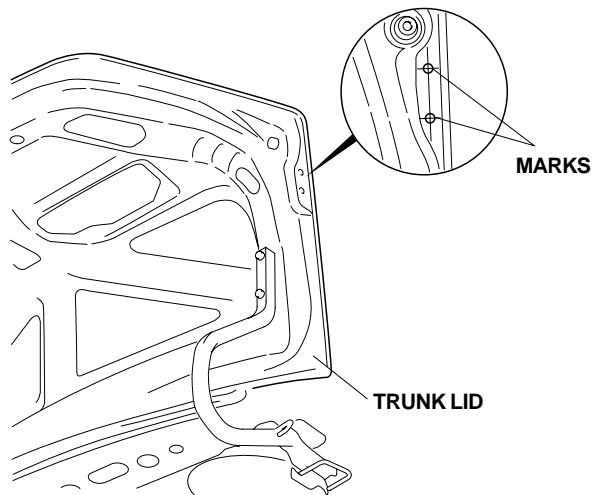

4. Have an assistant hold the trunk lid open. While wearing eye protection, drill an 8 mm hole through each mark:
 - First drill with a 3 mm bit, then with a 6 mm bit, and finally with an 8 mm bit.
 - Remove all burrs and metal shavings, and apply touch-up paint to the edges of the holes.
 - Repeat on the other side.

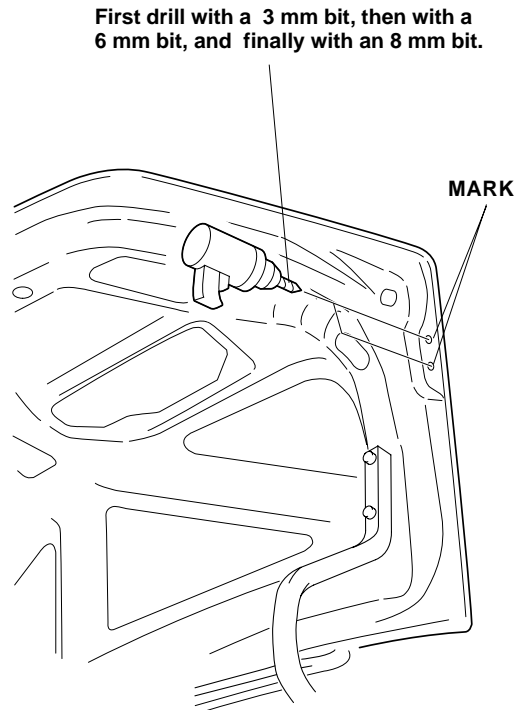

5. When the touch-up paint is dry, clean the area to be covered, and wax it with a high-quality paste wax.

6. Close the trunk lid. Position the template, printed side up, on the right (passenger's side) edge of the trunk lid. Align the two outer holes in the template with the two holes in the trunk lid. Using a felt-tip pen, mark the trunk lid as indicated on the template.

The left side of the trunk lid does not need a hole; mark only the right side for the rear wing spoiler harness.

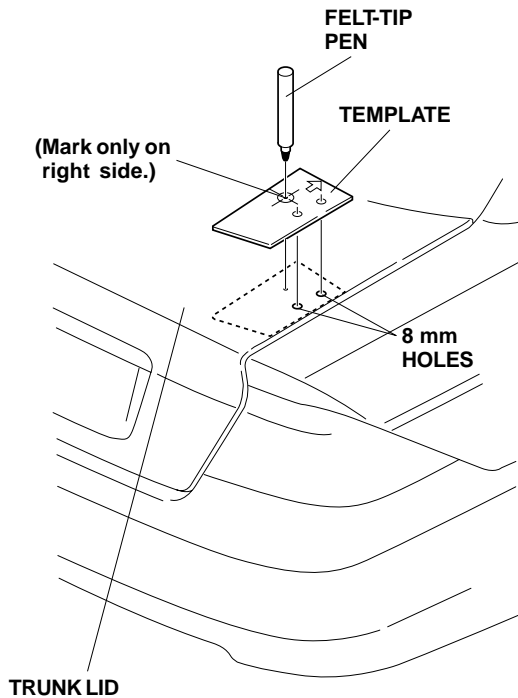

7. Remove the template, and lightly center-punch the mark.

8. While wearing eye protection, drill a 10 mm hole at the center-punched mark through the outer skin of the trunk lid; use a drill stop to avoid drilling through the inner panel:

- First drill with a 3 mm bit, then with a 6 mm bit, and finish with a 10 mm bit.
- Remove all burrs and metal shavings, and apply touch-up paint to the edge of the hole you drilled.

NOTE: This hole is for routing the spoiler harness through the trunk lid.

First drill with a 3 mm bit, then with a 6 mm bit, and finally with a 10 mm bit.

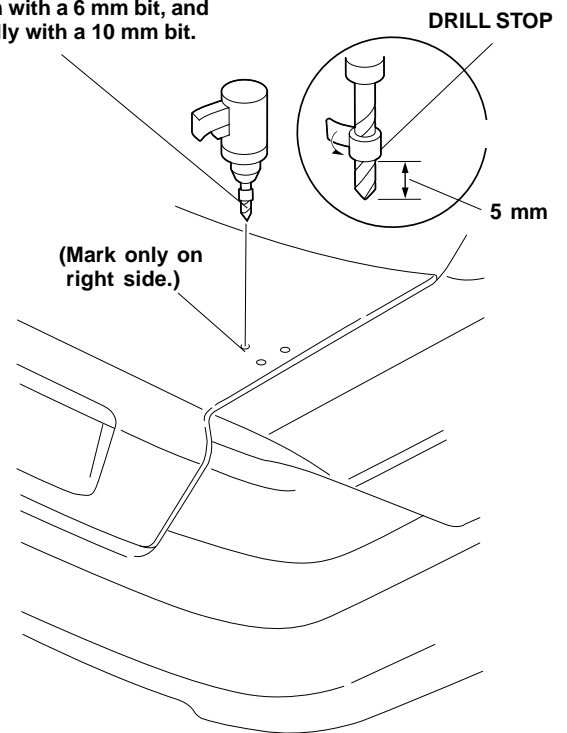

9. Hold the rear wing spoiler above the trunk, and route the harness of the rear wing spoiler down through the 10 mm hole you just drilled. Attach the grommet of the rear wing spoiler harness to the 10 mm hole.

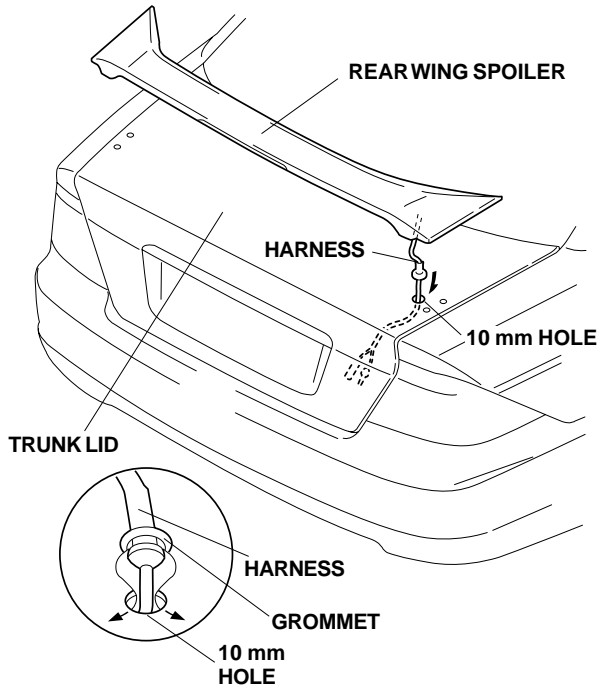

10. Position the trunk spoiler onto the trunk lid, and install the four cap nuts. Torque the cap nuts to 7 to 10 N•m (5 to 7 lb-ft).

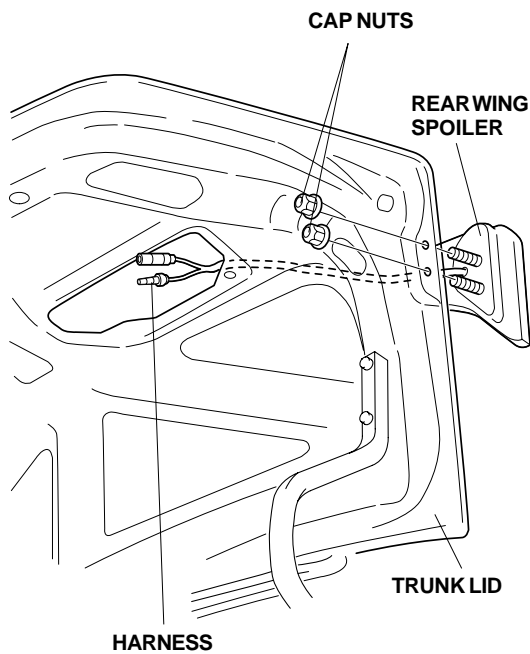

11. Route the harness of the rear wing spoiler inside the trunk lid.

Installing the Trunk Spring

12. Remove the center clip from the trunk springs.

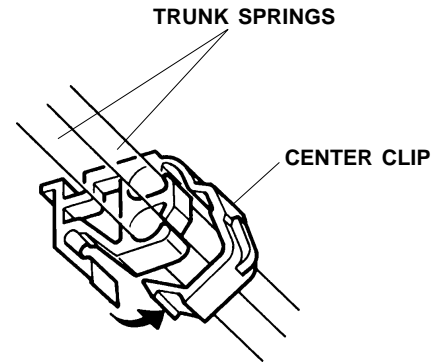

13. With an assistant holding the trunk lid open, remove the old trunk springs from the trunk lid hinge using the special tool. Wear heavy gloves to protect your hands, and pull the special tool slowly and carefully toward you.

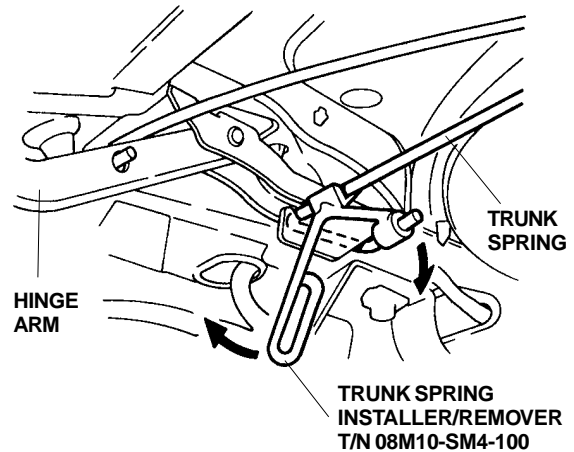

14. Install the right trunk spring and the left trunk spring in the reverse order of removal:
 - Set the tool on the marked end of each trunk spring.
 - Install the blue-marked spring in the slot in the right (passenger's) side trunk hinge arm and to the hinge bracket on the left (driver's) side of the vehicle. Install the white or yellow-marked spring in the slot in the left (driver's) side trunk hinge arm and to the hinge bracket on the right (passenger's) side of the vehicle.
 - Wearing gloves, rotate the tool as you pull it toward you.
 - Set the springs in the first notch (original position) of the hinge brackets.
 - Reinstall the center clip on the trunk springs.

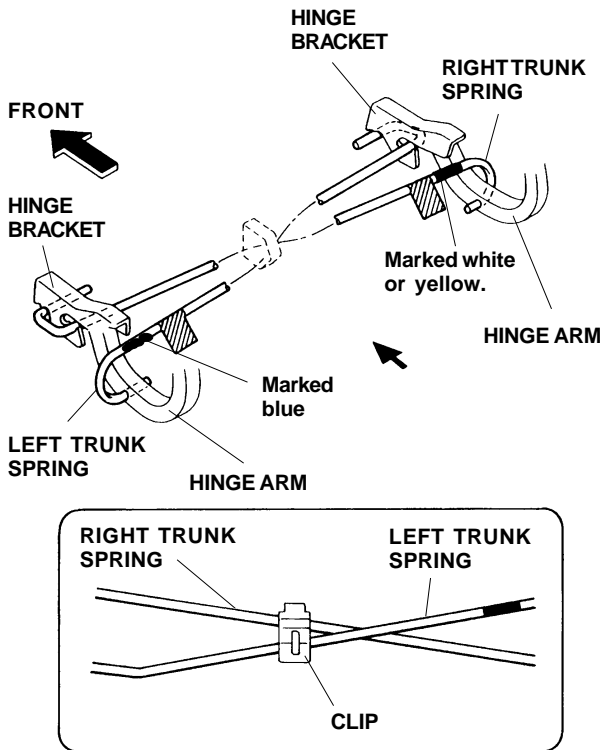

Routing the Wire Harness

15. Remove the two clips on the right side trunk panel.

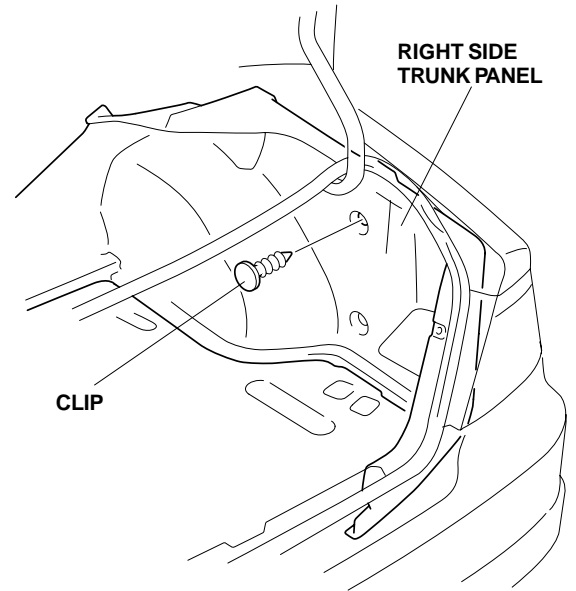

16. Unplug the 2-pin connector of the high-mount brake light from the rear metal shelf.

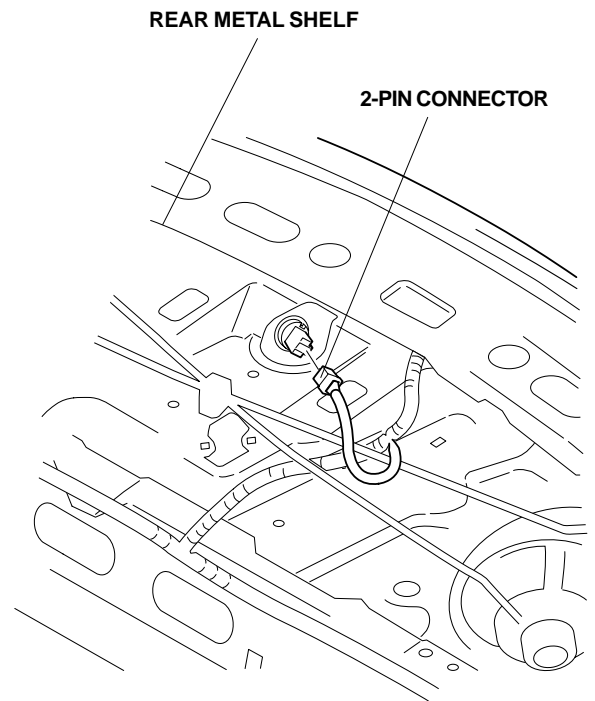

- Route the 2-pin connector from the high-mount brake light above the trunk springs, and plug it into the 2-pin connector of the spoiler harness.

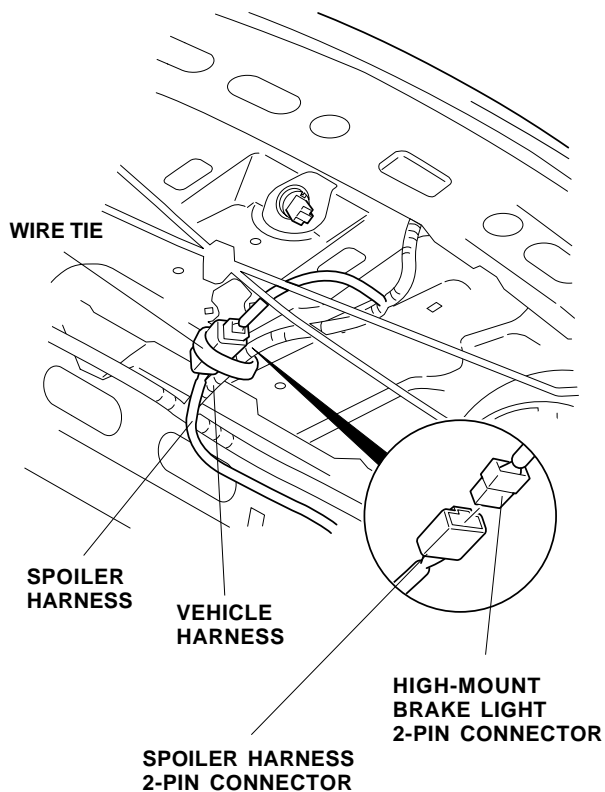

- Secure the 2-pin connector to the vehicle harness with one wire tie in the area shown.

- Gently pull down the right trunk panel, and locate the clip on the vehicle harness attached to the rear metal shelf. Align the lower green tape on the spoiler harness with the clip on the vehicle harness, and secure the spoiler harness to the vehicle harness with one wire tie in that area.

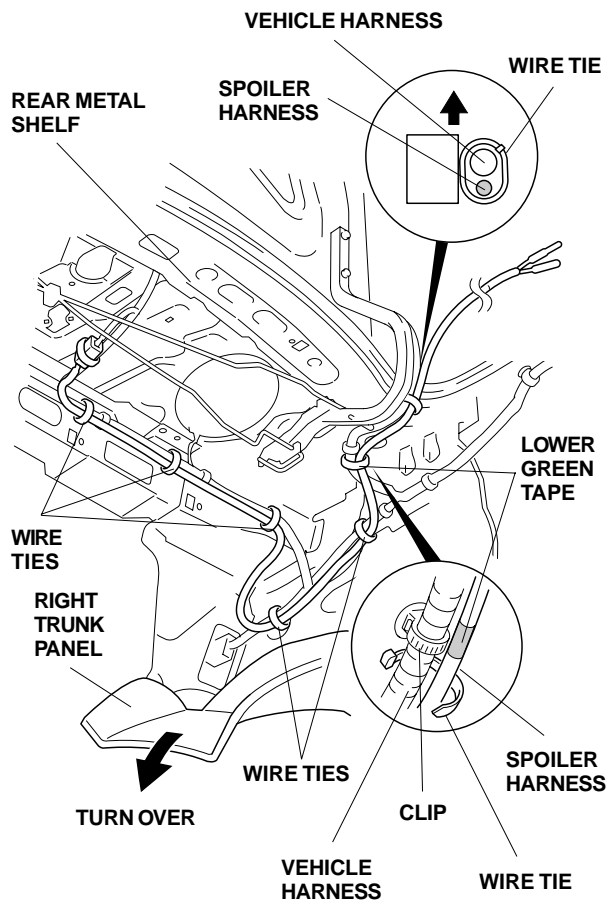

- Route the spoiler harness alongside the vehicle harness, and secure it with six wire ties in the areas shown.

- Continue routing the spoiler harness up the trunk arm and alongside the vehicle harness.

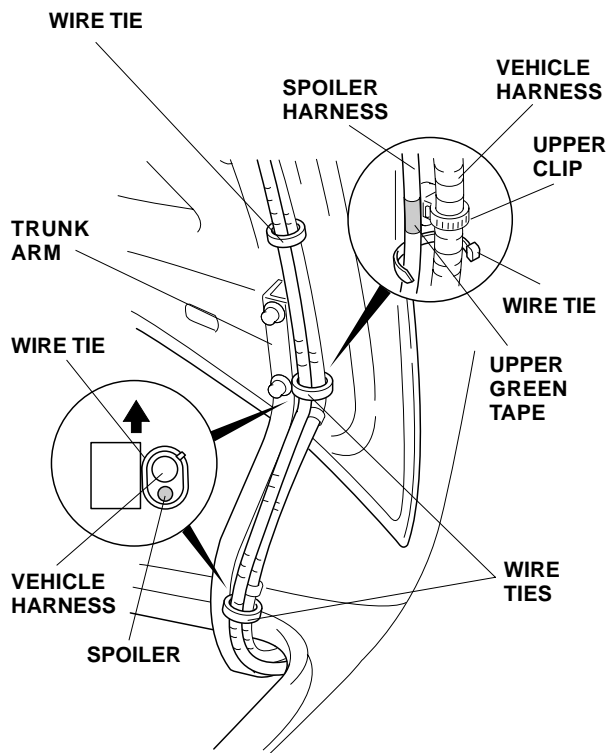

- Align the upper green tape on the spoiler harness with the upper clip on the vehicle harness, and secure the spoiler harness to the vehicle harness with one wire tie in the area shown.
- Secure the spoiler harness with two additional wire ties in the areas shown.

- Route the terminal ends on the spoiler harness inside the trunk lid. Plug the spoiler harness terminals into the rear wing spoiler harness terminals.

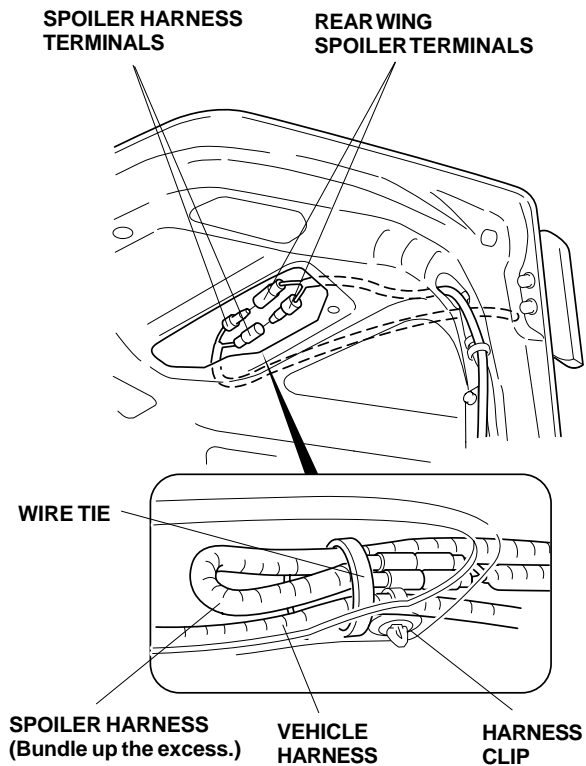

- Bundle up the excess wire harness, and secure it to the vehicle harness inside the trunk lid with one wire tie. Attach the wire tie near the harness clip.
- Check that all wire harnesses are routed properly and all connectors are plugged in.
- Reconnect the negative cable to the battery.
- Enter the customer's radio anti-theft code, and reset the radio station presets.
- Reset the clock.
- Press the brake pedal, and check that the spoiler brake light comes on.
- Reinstall all removed parts.

Use and Care of the Spoiler

- Handle the spoiler with care. It is not designed to absorb impact.
- Do not open or close the trunk lid by grasping the spoiler.
- Check the spoiler mounting nuts periodically, and retighten them if necessary.